



County of Fresno

DEPARTMENT OF PUBLIC WORKS AND PLANNING
STEVEN E. WHITE, DIRECTOR

DATE: February 26, 2020

TO: *

- * Development Services and Capital Projects, Attn: William M. Kettler, Division Manager
- * Development Services and Capital Projects, Attn: Chris Motta, Principal Planner
- * Development Services and Capital Projects, Current Planning, Attn: Marianne Mollring, Senior Planner
- * Development Services and Capital Projects, Policy Planning, ALCC, Attn: Mohammad Khorsand, Senior Planner
- * Development Services and Capital Projects, Zoning & Permit Review, Attn: Daniel Guitierrez/James Anders
- * Development Services and Capital Projects, Site Plan Review, Attn: Hector Luna
- * Development Services and Capital Projects, Building & Safety/Plan Check, Attn: Dan Mather
- * Development Engineering, Attn: Laurie Kennedy, Grading/Mapping
- * Road Maintenance and Operations, Attn: Wendy Nakagawa/Nadia Lopez
- * Design Division, Transportation Planning, Attn: Brian Spaunhurst/Gloria Hensley
- * Water and Natural Resources Division, Attn: Glenn Allen, Division Manager; Roy Jimenez
- * Department of Public Health, Environmental Health Division, Attn: Deep Sidhu/Steven Rhodes
- Agricultural Commissioner, Attn: Rusty Lantsberger
- County Counsel, Attn: Alison Samarin, Deputy County Counsel
- * U.S. Fish and Wildlife Service, San Joaquin Valley Division, Attn: Matthew Nelson, Biologist
- * CA Department of Fish and Wildlife, Attn: Craig Bailey, Environmental Scientist & R4CEQA@wildlife.ca.gov
- State Water Resources Control Board, Division of Drinking Water, Fresno District, Attn: Jose Robledo, Caitlin Juarez
- Dumna Wo Wah Tribal Government, Attn: Robert Ledger, Tribal Chairman/Chris Acree, Cultural Resources Analyst
- Picayune Rancheria of the Chukchansi Indians, Attn: Heather Airey/Cultural Resources Director
- Santa Rosa Rancheria Tachi Yokut Tribe, Attn: Ruben Barrios, Tribal Chairman/Hector Franco, Director/Shana Powers, Cultural Specialist II
- Table Mountain Rancheria, Attn: Robert Pennell, Cultural Resources Director
- * San Joaquin Valley Unified Air Pollution Control District (PIC-CEQA Division), Attn: PIC Supervisor
- McMullin GSA, Attn: Matthew H. Hurley, General Manager at www.mcmullinarea.org
- * City of Fresno Fire Department/North Central Fire Protection District, Attn: George Mavrikis, Fire Marshall

FROM: Ejaz Ahmad, Planner 
Development Services and Capital Projects Division

SUBJECT: Initial Study Application No. 7808, Classified Conditional Use Permit Application No. 3670.

APPLICANT: Baker Commodities, Inc.

DUE DATE: March 11, 2020

The Department of Public Works and Planning, Development Services and Capital Projects Division is reviewing the subject application proposing to allow approximately 870 square feet expansion of a cooker building to accommodate a fourth cooker at an existing 39.10-acre animal rendering facility in the AE-20 (Exclusive Agricultural, 20-acre minimum parcel size) Zone District.

The Department is also reviewing for environmental effects, as mandated by the California Environmental Quality Act (CEQA) and for conformity with plans and policies of the County.

Based upon this review, a determination will be made regarding conditions to be imposed on the project, including necessary on-site and off-site improvements.

We must have your comments by **March 11, 2020**. Any comments received after this date may not be used.

NOTE - THIS WILL BE OUR ONLY REQUEST FOR WRITTEN COMMENTS. If you do not have comments, please provide a "NO COMMENT" response to our office by the above deadline (e-mail is also acceptable; see email address below).

Please address any correspondence or questions related to environmental and/or policy/design issues to me, Ejaz Ahmad, Planner, Development Services and Capital Projects Division, Fresno County Department of Public Works and Planning, 2220 Tulare Street, Sixth Floor, Fresno, CA 93721, or call (559) 600-4204, or email eahmad@fresnocountyca.gov.

EA:

G:\4360Devs&Pln\PROJSEC\PROJDOCS\CUP\3600-3699\3670\ROUTING\CUP 3670 Routing Ltr.doc

Activity Code (Internal Review): 2381

Enclosures



Fresno County Department of Public Works and Planning

Date Received: 02/20/2020

CUP3670

(Application No.)

MAILING ADDRESS:

Department of Public Works and Planning
Development Services Division
2220 Tulare St., 6th Floor
Fresno, Ca. 93721

LOCATION:

Southwest corner of Tulare & "M" Streets, Suite A
Street Level
Fresno Phone: (559) 600-4497
Toll Free: 1-800-742-1011 Ext. 0-4497

APPLICATION FOR:

- X Pre-Application (Type) CUP Modification 19-100057
Amendment Application
Amendment to Text
X Conditional Use Permit
Variance (Class)/Minor Variance
Site Plan Review/Occupancy Permit
No Shoot/Dog Leash Law Boundary
General Plan Amendment/Specific Plan/SP Amendment
Time Extension for
Director Review and Approval
for 2nd Residence
Determination of Merger
Agreements
ALCC/RLOCC
Other

DESCRIPTION OF PROPOSED USE OR REQUEST:

Addition of fourth cooker at existing animal rendering facility., including expansion of an existing cooker building

CEQA DOCUMENTATION: X Initial Study PER N/A

PLEASE USE FILL-IN FORM OR PRINT IN BLACK INK. Answer all questions completely. Attach required site plans, forms, statements, and deeds as specified on the Pre-Application Review. Attach Copy of Deed, including Legal Description.

LOCATION OF PROPERTY: South Side of Jensen Avenue
Between S. Lassen Ave. and S. Modoc Ave
Street address: 16801 W. Jensen Ave., Kerman, Ca 93630

APN: 020-042-03S Parcel size: 3900 X 1 Section(s)-Twp/Rg: S23 - T14S S/R17 E

ADDITIONAL APN(s):

I, [Signature] (signature), declare that I am the owner, or authorized representative of the owner, of the above described property and that the application and attached documents are in all respects true and correct to the best of my knowledge. The foregoing declaration is made under penalty of perjury.

Table with 5 columns: Name, Address, City, Zip, Phone. Rows include Baker Commodities, Inc. and Patrick Faেকে, CPA.

CONTACT EMAIL: Steve Dessauer (559) 515-1258; SDessauer@bakercommodities.com

OFFICE USE ONLY (PRINT FORM ON GREEN PAPER)

Application Type / No.: CUP 3670 Fee: \$ 4,569.00
Application Type / No.: Pre-app. Credit Fee: \$ -247.00
PER/Initial Study No.: IS 7808 Fee: \$ 3,901.00
Ag Department Review: Fee: \$ 93.00
Health Department Review: Fee: \$ 992.00
Received By: EIAZ Invoice No.: TOTAL: \$ 9,308.00

UTILITIES AVAILABLE:

WATER: Yes [] / No [X]
Agency:
SEWER: Yes [] / No [X]
Agency:

STAFF DETERMINATION: This permit is sought under Ordinance Section:

Sect-Twp/Rg: - T - S/R - E

Related Application(s): CUP 567; CUP 1964
Zone District: AE-20
Parcel Size: 39.10 acrs.

APN # - - -
APN # - - -
APN # - - -
APN # - - -



**Development Services
and
Capital Projects
Division**

Mail To:
David Rocha
P.O. Box 416
Kerman, CA 93630

Pre-Application Review

Department of Public Works and Planning

NUMBER: 20-100057
APPLICANT: Karl Laney
PHONE: (714) 376-6531
E-mail: klaney@montrose-env.com

PROPERTY LOCATION: 16801 W. Jensen Ave.
APN: 020 - 042 - 03s ALCC: No No Yes # VIOLATION NO. None
CNEL: No X Yes (level) LOW WATER: No X Yes WITHIN 1/2 MILE OF CITY: No No Yes
ZONE DISTRICT: AE-20; SRA: No No Yes X HOMESITE DECLARATION REQ'D.: No No Yes
LOT STATUS:

Zoning: (X) Conforms; () Legal Non-Conforming lot; () Deed Review Req'd (see Form #236)
Merger: May be subject to merger: No X Yes ZM# Initiated In process
Map Act: () Lot of Rec. Map; () On '72 rolls; (X) Other; () Deeds Req'd (see Form #236)
SCHOOL FEES: No Yes X DISTRICT: Kerman USD PERMIT JACKET: No Yes X
FMFCD FEE AREA: (X) Outside () District No.: FLOOD PRONE: No X Yes
PROPOSAL CUP TO ALLOW THE EXPANSION OF AN EXISTING ANIMAL PROCESSING FACILITY.

Plan Check # 19-0019 (A#19-100198) currently in process.
COMMENTS: Previous Land Use Approvals are CUP-280, CUP-567 and CUP1459.
ORD. SECTION(S): 816.3-A, 873 BY: Daniel Gutierrez DATE: 1/10/2020

GENERAL PLAN POLICIES:

LAND USE DESIGNATION: AGRICULTURE () GPA:
COMMUNITY PLAN: () AA:
REGIONAL PLAN: () CUP: \$4,569.00
SPECIFIC PLAN: () DRA:
SPECIAL POLICIES: () VA:
SPHERE OF INFLUENCE: () AT:
ANNEX REFERRAL (LU-G17/MOU): () JT:

PROCEDURES AND FEES:

() MINOR VA:
() HD: \$992.00
() AG COMM: \$93.00
() ALCC:
() IS/PER*: \$3,901.00
() Viol. (35%):
() Other:
Filing Fee: \$ 9,555.00
Pre-Application Fee: \$247.00
Total County Filing Fee: \$ 9,308.00

COMMENTS:

FILING REQUIREMENTS:

- (X) Land Use Applications and Fees
- (X) This Pre-Application Review form
- (X) Copy of Deed / Legal Description
- (X) Photographs
- () Letter Verifying Deed Review
- () IS Application and Fees* * Upon review of project materials, an Initial Study (IS) with fees may be required.
- (X) Site Plans - 4 copies (folded to 8.5"x11") + 1 - 8.5"x11" reduction
- (X) Floor Plan & Elevations - 4 copies (folded to 8.5"x11") + 1 - 8.5"x11" reduction
- (X) Project Description / Operational Statement (Typed)
- () Statement of Variance Findings
- () Statement of Intended Use (ALCC)
- () Dependency Relationship Statement
- () Resolution/Letter of Release from City of

OTHER FILING FEES:

- () Archaeological Inventory Fee: \$75 at time of filing (Separate check to Southern San Joaquin Valley Info. Center)
- (X) CA Dept. of Fish & Wildlife (CDFW): (\$50) (\$50+\$2,406.75) (Separate check to Fresno County Clerk for pass-thru to CDFW. Must be paid prior to IS closure and prior to setting hearing date.)

Referral Letter # _____

BY: Ejaz Ahmad DATE: 01-10-20
PHONE NUMBER: (559) 600-4204

NOTE: THE FOLLOWING REQUIREMENTS MAY ALSO APPLY:

- () COVENANT
- () MAP CERTIFICATE
- () PARCEL MAP
- () FINAL MAP
- () FMFCD FEES
- () ALUC or ALCC
- (X) SITE PLAN REVIEW
- (X) BUILDING PLANS
- (X) BUILDING PERMITS
- () WASTE FACILITIES PERMIT
- (X) SCHOOL FEES
- () OTHER (see reverse side)

PLU # 113 Fee: \$247.00
Note: This fee will apply to the application fee if the application is submitted within six (6) months of the date on this receipt.

OVER.....

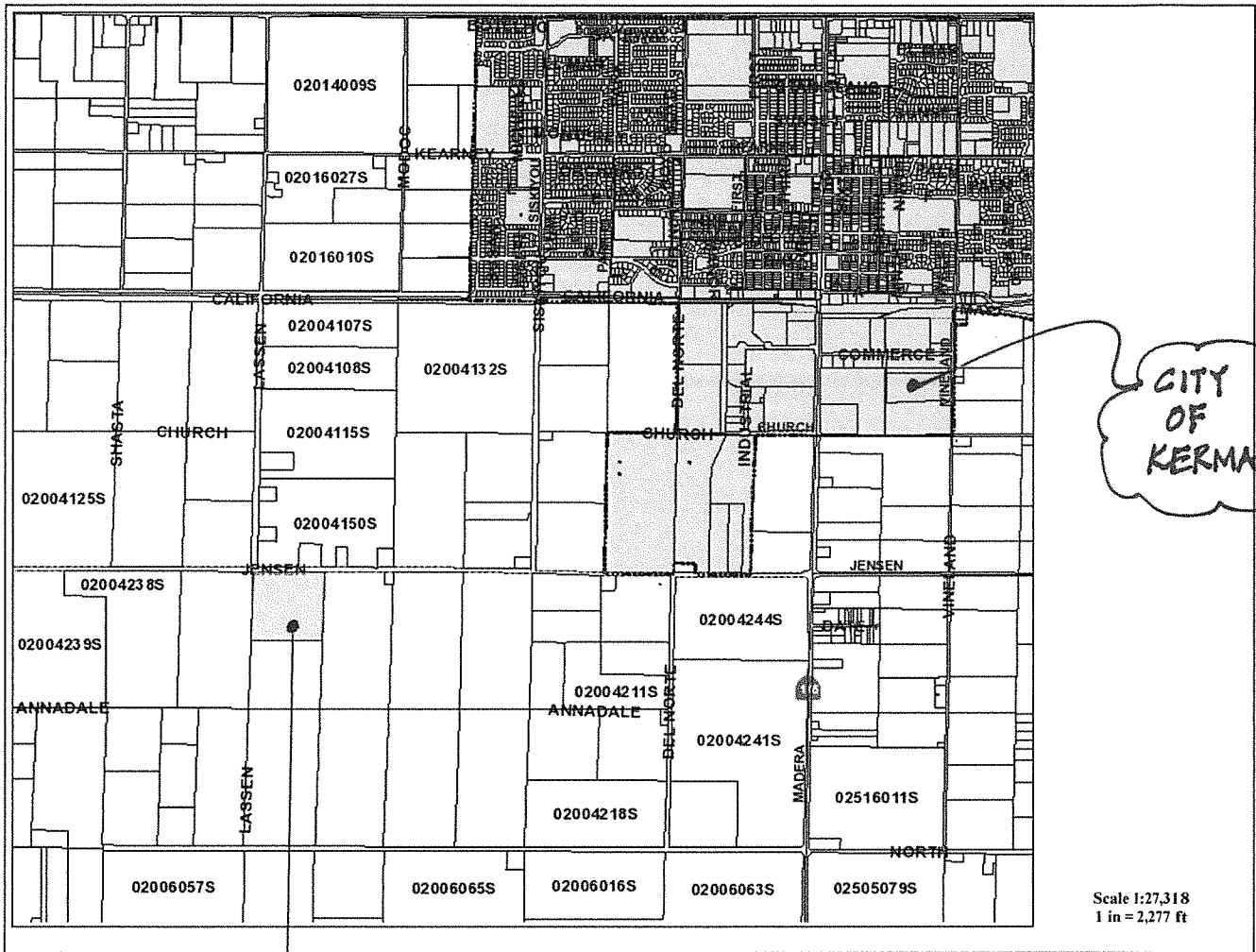

PROJECT SITE

CITY OF KERMAN

Scale 1:27,318
1 in = 2,277 ft

SEC'S. 14, 15, 22, 23 & 24, T.14 S., R.17 E. M. D. B. & M.

20-04

Tax Area
120-000 13-043
120-001
120-012

— NOTE —
This map is for Assessment purposes only.
It is not to be construed as portraying legal
ownership or divisions of land for purposes
of zoning or subdivision law.

1" = 1200'

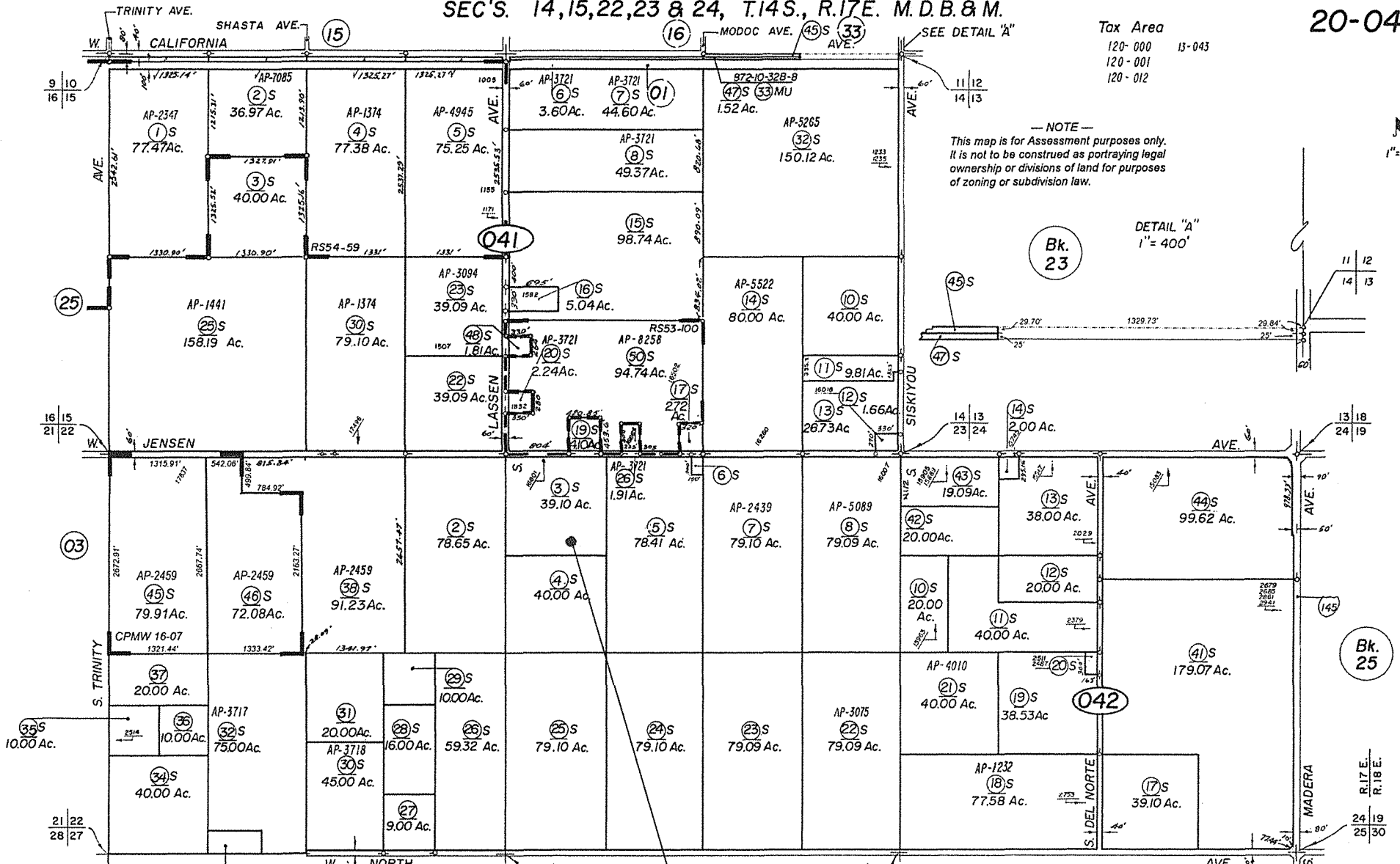

Bk. 23

DETAIL "A"
1" = 400'

Bk. 25

Agricultural Preserve
Record of Survey-Bk. 53, Pg. 100
Record of Survey-Bk. 54, Pgs. 59-63
Certificate of Parcel Map Waiver No. 16-07, Doc 92600, 7/28/17

Assessor's Map Bk. 20 - Pg. 04
County of Fresno, Calif.

NOTE - Assessor's Block Numbers Shown in Ellipses.
Assessor's Parcel Numbers Shown in Circles.

PROJECT
SITE



County of Fresno

DEPARTMENT OF PUBLIC WORKS AND PLANNING
STEVEN E. WHITE, DIRECTOR

INITIAL STUDY APPLICATION

INSTRUCTIONS

Answer all questions completely. An incomplete form may delay processing of your application. Use additional paper if necessary and attach any supplemental information to this form. Attach an operational statement if appropriate. This application will be distributed to several agencies and persons to determine the potential environmental effects of your proposal. Please complete the form in a legible and reproducible manner (i.e., USE BLACK INK OR TYPE).

OFFICE USE ONLY

IS No. 7808

Project No(s). CUP3670

Application Rec'd.:
02-20-2020

GENERAL INFORMATION

- Property Owner: Baker Commodities, Inc. Phone/Fax (559) 846-9393
Mailing Address: P.O. Box 416 Kerman CA 93630
Street City State/Zip
- Applicant: Baker Commodities, Inc Phone/Fax: (559) 846-9393
Mailing Address: P.O. Box 416 Kerman CA 93630
Street City State/Zip
- Representative: Karl Lany, Montrose Environmental Solutions Phone/Fax (714) 376-6531
Mailing Address: 1631 E. St. Andrew Pl. Santa CA 92705
Street City State/Zip
- Proposed Project: Installation of cooker #4, reinstall a previously-operated condenser, 870 square ft expansion of existing 20,500 square foot processing building.
- Project Location: Existing building at Baker – Kerman facility
- Project Address: 16801 W. Jensen Ave., Kerman CA 93630
- Section/Township/Range: 23 / 14S / 17E 8. Parcel Size: 39.10 acres
- Assessor's Parcel No. 020-042-035 OVER.....

10. Land Conservation Contract No. (If applicable): na

11. What other agencies will you need to get permits or authorization from:

<u> </u> LAFCo (annexation or extension of services)	<u> X </u>	SJVUAPCD (Air Pollution Control District)
<u> </u> CALTRANS	<u> </u>	Reclamation Board
<u> </u> Division of Aeronautics	<u> </u>	Department of Energy
<u> </u> Water Quality Control Board	<u> </u>	Airport Land Use Commission
<u> </u> Other _____		

12. Will the project utilize Federal funds or require other Federal authorization subject to the provision of the National Environmental Policy Act (NEPA) of 1969? Yes X No

If so, please provide a copy of all related grant and/or funding documents, related information and environmental review requirements.

13. Existing Zone District¹: _____

14. Existing General Plan Land Use Designation¹: _____

ENVIRONMENTAL INFORMATION

15. Present land use: Industrial / agricultural use, including existing animal rendering facility, administrative offices, evaporation lagoons.

Describe existing physical improvements including buildings, water (wells) and sewage facilities, roads, and lighting. Include a site plan or map showing these improvements:

Describe the major vegetative cover: None at the project site. Property is already developed

Any perennial or intermittent water courses? If so, show on map: No

Is property in a flood-prone area? Describe: No

16. Describe surrounding land uses (e.g., commercial, agricultural, residential, school, etc.):

North: Agricultural, with residence

South: Agricultural, controlled by applicant

East: Agricultural, controlled by applicant

West: Agricultural, controlled by applicant

17. What land use(s) in the area may be impacted by your Project? None, facility has been in operation for approximately 60 years. Project consists of a minor expansion (870 square ft) to an existing structure, addition of fourth identical cooker and potential increases in production volume as permitted by SJVAPCD

18. What land use(s) in the area may impact your project? None

19. **Transportation:**

NOTE: The information below will be used in determining traffic impacts from this project. The data may also show the need for a Traffic Impact Study (TIS) for the project.

A. Will additional driveways from the proposed project site be necessary to access public roads?
 Yes X No

B. **Daily traffic generation:**

Residential - Number of Units _____
Lot Size _____
Single Family _____
Apartments _____

Commercial - Number of Employees None
Number of Salesmen None
Number of Delivery Trucks 10 max. 2-4 daily average
Total Square Footage of Building 870

Describe and quantify other traffic generation activities: Additional vehicles traffic (employees, service, etc) is not expected to support facility operations. Approximately 8-12 contractor workers are expected during the two month preconstruction phase of the project. They will be transported in 2-4 passenger vehicles or light duty trucks. Only minimal equipment such as cranes, lifts and concrete trucks is expected during the construction phase of the project.

20. Describe any source(s) of noise from your project that may affect the surrounding area: Project consists of a cooker that is identical to existing cookers, increase in noise is not expected. Operating hours may be reduced.

21. Describe any source(s) of noise in the area that may affect your project: None

22. Describe the probable source(s) of air pollution from your project: *Cooker is operated by steam and does not in itself generate criteria pollutants. Such pollutants are generated by the existing boilers that serve the cooker. Baker has recently replaced an older boiler with a new ultra-low NOx unit that meets BACT as defined by SJVAPCD. The boiler is also more efficient and consumes less fuel than previous boiler. Odors and organic emissions from the cooking process are controlled by a new regenerative thermal oxidizer which emits primarily NOx and CO. The production increase may lead to minor increases of PM10 emissions due to material handling. The project has been evaluated by SJVAPCD, which has determined that stationary source emissions attributed to the project are either within existing permitted levels or in cases where emission increases may occur, those increases allowable pursuant to applicable local, state and federal regulations.*

If maximum annual production proposed to be allowed by SJVAPCD were to be achieved, increased volume would result in increased heavy-duty vehicle trips (up to 10 trucks) to the facility. Actual average daily truck traffic is expected to increase by no more than 2-4 trips per day.

Without the project, those truck trips may be longer in distance as animal feedstock would have to be diverted to rendering facilities located farther away or to local landfills.

23. Proposed source of water: (X) private well -
() community system³--name: _____ OVER.....

24. Anticipated volume of water to be used (gallons per day)²: *Additional water use is expected to be minor – approximately 4,000 to 8,000 gallons per day based upon boiler capacity and potential production increases.*

25. Proposed method of liquid waste disposal:
() septic system/individual
() community system³--name *No offsite waste is expected. Volumes are within existing RWOCB permitted limits. Much water is collected as cooking vapors are condensed. Some of condensate is used for facility wash-down. Remaining water produced in the process passes through an oil / water separator and then diverted to existing lined evaporation lagoons.*

26. Estimated volume of liquid waste (gallons per day)²: *Additional water collection due to the project is estimated to be approximately 38,000 gallons per day at maximum and less than 15,000 gallons per day on average.*

27. Anticipated type(s) of liquid waste: *water*

28. Anticipated type(s) of hazardous wastes²: *na*

29. Anticipated volume of hazardous wastes²: *na*

30. Proposed method of hazardous waste disposal²: *na*

31. Anticipated type(s) of solid waste: *na*

32. Anticipated amount of solid waste (tons or cubic yards per day): *none*

33. Anticipated amount of waste that will be recycled (tons or cubic yards per day): na

34. Proposed method of solid waste disposal: na

35. Fire protection district(s) serving this area: Fresno County North-Central

36. Has a previous application been processed on this site? If so, list title and date: _____

37. Do you have any underground storage tanks (except septic tanks)? Yes _____ No X

38. If yes, are they currently in use? Yes _____ No na

TO THE BEST OF MY KNOWLEDGE, THE FOREGOING INFORMATION IS TRUE.

SIGNATURE
EVP-000

2/11/2020
DATE

¹Refer to Development Services and Capital Projects Conference Checklist

²For assistance, contact Environmental Health System, (559) 600-3357

³For County Service Areas or Waterworks Districts, contact the Resources Division, (559) 600-4259

(Revised 12/14/18)

NOTICE AND ACKNOWLEDGMENT

INDEMNIFICATION AND DEFENSE

The Board of Supervisors has adopted a policy that applicants should be made aware that they may be responsible for participating in the defense of the County in the event a lawsuit is filed resulting from the County's action on your project. You may be required to enter into an agreement to indemnify and defend the County if it appears likely that litigation could result from the County's action. The agreement would require that you deposit an appropriate security upon notice that a lawsuit has been filed. In the event that you fail to comply with the provisions of the agreement, the County may rescind its approval of the project.

STATE FISH AND WILDLIFE FEE

State law requires that specified fees (effective January 1, 2019: \$3,271.00 for an EIR; \$2,354.75 for a Mitigated/Negative Declaration) be paid to the California Department of Fish and Wildlife (CDFW) for projects which must be reviewed for potential adverse effect on wildlife resources. The County is required to collect the fees on behalf of CDFW. A \$50.00 handling fee will also be charged, as provided for in the legislation, to defray a portion of the County's costs for collecting the fees.

The following projects are exempt from the fees:

1. All projects statutorily exempt from the provisions of CEQA (California Environmental Quality Act).
2. All projects categorically exempt by regulations of the Secretary of Resources (State of California) from the requirement to prepare environmental documents.

A fee exemption may be issued by CDFW for eligible projects determined by that agency to have "no effect on wildlife." That determination must be provided in advance from CDFW to the County at the request of the applicant. You may wish to call the local office of CDFW at (559) 222-3761 if you need more information.

Upon completion of the Initial Study you will be notified of the applicable fee. Payment of the fee will be required before your project will be forwarded to the project analyst for scheduling of any required hearings and final processing. The fee will be refunded if the project should be denied by the County.



Applicant's Signature

EVP - COO

7/11/2020

Date

**Baker Commodities Cooker Addition Project
Operational Statement Checklist
16801 West Jensen Avenue
Kerman, California 93630**

CUP 3670
RECEIVED
COUNTY OF FRESNO
FEB 20 2020

DEPARTMENT OF PUBLIC WORKS
AND PLANNING
DEVELOPMENT SERVICES DIVISION

1. Nature of Operation and Proposal

Facility Overview

The Baker facility is located at 16801 West Jensen Avenue in Kerman, California. The Kerman facility is an animal rendering facility, which produces meat and bone meal as the final product. The facility is generally surrounded by agricultural land; and there is no K-12 school within 1,000 feet of the facility. The Baker facility is comprised of 12 acres of developed industrial space. Baker also controls approximately 601 acres to the east, south and west of the facility that are dedicated to agricultural crop production.

Baker operates an animal rendering plant animal that processes deadstock from local agricultural facilities. During the process deadstock are received and conveyed through a series of grinders, presses and its three cookers to remove water, separate fats that become tallow and reduce the remaining solids to meat and bone meal. The resulting commodities are then stored in tanks and silos at the facility and ultimately sold for a variety of industrial and agricultural uses. The Baker facility is regulated by the San Joaquin Valley Air Pollution Control District (SJVAPCD) and is currently restricted to process no more than 695 tons per day and 165,564 tons per year of raw material. The permit also limits meat / bone meal loadout to 400 tons per day and 82,334 tons per year.

The cookers that are used in the rendering process rely upon high pressure steam, rather than direct combustion. The steam is produced by natural gas-fired industrial boilers that are located at the facility. The newest and primary boiler is designed to achieve a NOx emission level that is below 5 ppmv at 3% O₂. It is considered to be an "ultra-low NOx unit" that meets best available control technology standards by the San Joaquin Valley Air Pollution Control District (SJVAPCD).

Through the rendering process, water is captured as steam from the cookers and condensed. A portion of that water is used as boiler makeup water and also for plant wash-down. Remaining wastewater is sent through an oil/water separator. The oil is returned to the rendering process and the remaining wastewater is diverted to on-site lined evaporation ponds that are permitted by the Regional Water Quality Control Board (RWQCB).

Once water has been condensed from the cooker vapor stream, the resulting dry exhaust stream is vented along with exhaust streams from other key devices to a regenerative thermal oxidizer (RTO) to destroy organic gases and control odors. The RTO is considered by SJVAPCD to meet best available control technology standards. Baker also operates a thermal oxidizer as a backup system to the RTO.

Proposal

To reduce the risk of odor nuisance, the SJVAPCD requires that Baker process raw material within 24 hours of its arrival to the facility. During summer months raw material may be degraded to a greater extent than normal when it arrives at the facility. Processing under such conditions requires additional time and Baker's ability to meet SJVAPCD process turnaround time limits and reduce nuisance odors is jeopardized. Compliance with turnaround time limits is further jeopardized on peak volume days when regional agricultural operations experience higher than normal animal mortality due to extreme weather conditions.

To minimize production turnaround and reduce the risk of public nuisance, Baker proposes to add a fourth cooker to its facility. The fourth cooker will also allow Baker to process material approximately 33% faster than is can with its existing equipment. The additional cooker may also allow Baker to meet normal production demands in two shifts per day, rather than the three daily shifts that are common under present operations. The project includes other minor modifications such as the installation of a condenser to serve the new cooker and increasing the raw material capacity of the feed hopper to 3,850 pounds from the existing capacity of 3,500 pounds.

The fourth cooker requires a footprint of approximately 250 square feet. It will be installed adjacent to the existing cookers at the north side of the existing building within a building expansion of approximately 870 square feet. The expansion will be located on land that is already developed and in use. No new or additional storage tanks, silos, combustion sources, receiving pit capacity or water treatment facilities are required to support the project. All existing surrounding agricultural land will remain as-is.

The project is subject to SJVAPCD permitting. Baker has submitted an application to construct the cooker. Based upon the SJVAPCD permitting analysis, the facility can increase allowable raw material throughput from the existing 695 tons per day and 165,564 tons per year to new limits of 960 tons per day and 252,500 tons per year based upon the capacity of the cooker and SJVAPCD permitting policies. SJVAPCD has issued draft construction permits for the project that would allow the production increases. In doing so, SJVAPCD confirms that the new cooker and maximum production volumes meet all SJVAPCD regulations and do not result in significant impacts to air quality, public nuisance or public health. The project would increase daily emissions of NO_x, CO, PM₁₀ and VOC (criteria pollutants) by only minor amounts if all four cookers were operated at maximum capacity for 24 hours (although such production levels are not anticipated). Due to efficiencies that were recently gained through the installation of the RTO, potential annual emissions of criteria pollutants will not increase over currently-permitted levels. These efficiencies also ensure that hazardous air pollutants and health risk resulting from the project are below currently permitted levels.

2. Operational Timeline

Baker currently operates three eight-hour shifts per day and seven days per week. The project will allow Baker to reduce its operating schedule to six days per week. It is possible that during off-peak periods, Baker may be able to meet production needs with only two shifts per day. The project will allow Baker to better manage preventative maintenance operations and avoid unscheduled shutdowns and the need to send material to local landfills.

The project has been in permitting with Fresno County and SJVAPCD since the spring of 2019 and Baker's goal is to have the cooker in place by the summer of 2020 when deadstock volumes are expected to increase and the quality of raw material is expected to be degraded. Without the project, Baker may not be able to process the expected volume of locally-generated deadstock and local agricultural facility operators may be forced to deliver deadstock to local landfills. California law requires that fallen livestock be processed by a licensed rendering facility and even short-term interruptions in rendering operations can upset local agricultural operations and present public health and nuisance impacts.

3. Number of Customers or Visitors

Current production levels could generate approximately 42 round-trip heavy-duty truck trips on a peak operating day. Based upon existing average production volumes, however, approximately 27 heavy duty truck trips are made to Baker on a daily basis. These trips include approximately 20 trucks that bring in raw material, and 7 trucks that remove finished commodities. If the annual production limits that are contained in the proposed SJVAPCD permits were to be achieved, average daily truck traffic would increase by approximately 10 vehicles. It is not likely, however, that permitted maximum annual throughput would ever be reached. Given expectations in average daily production, the expected increase in average daily truck traffic due to the project is 2-4 trucks.

The estimated average one-way truck trip distance to be approximately 50 miles. Most trucks serving the facility are routed along Hwy 99 to Jensen Avenue. Without the project, truck traffic will be diverted to facilities as far away as Los Angeles or to local landfills. As such, the project would not necessarily increase regional heavy-duty truck traffic.

4. Number of Employees

The Baker Kerman facility currently employs 80 full-time. The project would not result in an increase in employees. Approximately 8-12 contractor employees will be on-site during construction in 2-4 vehicles.

5. Service and Delivery Vehicles

The project would not significantly affect parcel delivery, maintenance and visitor trips to the facility.

6. Access to the Site

All access to the site is granted on the north side of the facility on Jensen Road. The project will not alter the point of access.

7. Number of Parking Spaces for Employees

There will be no increase in employee levels and no increase in parking spaces. Employees will continue to utilize parking facilities that are located within the existing facility.

8. On site-sales

Commodities produced at the facility are not sold-on site. All commodities are trucked off-site in bulk.

9. Equipment

The project consists of one Dupps Model 1200 screw conveyor cooker. It is identical to the other cookers that are presently in use at the facility. The cooker utilizes steam from the existing boilers and vents to existing condensers and emission control system. A small condenser will also be installed with the cooker. No other major equipment is included with the project.

10. Material Use and Storage

The rendering process at Baker does not rely upon significant material use other than the process feedstock. Storage facilities are limited to the resulting commodities / byproducts. Raw materials are brought onsite and stored at the receiving slab. SJVAPCD permit conditions require that all incoming raw material trucks be unloaded within two hours and that all material be processed within 24 hours of arriving at the facility. Trucks unload to a concrete slab specified by SJVAPCD permit conditions to 195 ft by 175 ft. The project will not alter raw material receiving, storage or process restrictions. It is expected, instead, to allow Baker to more easily comply with existing permit conditions.

Meat / bone meal and tallow that is produced in the rendering process is stored on-site. Meat / bone meal is stored in two existing silos or in a designated area under tarps. Tallow is stored in one of approximately 20 storage tanks. Some of the tanks may also be used to store process water prior to separation and transfer to the existing lined evaporation lagoons.

11. Does the use cause any unsightly appearance?

The main production facility is set back from Jensen Avenue by approximately 500 feet and is generally an enclosed structure. A business office is located directly in front of the production facility along Jensen Avenue. The facility is surrounded by acres of Baker-owned agricultural land to the east, south and west.

The project would not significantly alter the appearance of the facility. The new cooker will be housed in an approximately 870 square foot extension of the existing 20,500 square foot processing building and will include walls and a roof. The finish of the extension will match the existing structure. The condenser will be located next to the existing condensers and all four units have a relatively low profile, given their setback from Jensen Avenue and placement behind the administrative building.

12. List any solid and liquid waste to be produced.

The rendering process does not produce solid waste. The resulting products are commodities that are sold for a variety of agricultural and industrial uses.

The rendering process produces water. If that plant were operated at maximum capacity, the project would produce an additional 38,000 gallons per day of water on days on average. Based upon expected production, however, the average increase in water production is estimated to be less than 15,000 gallons per day. A portion of that water will be used for facility wash-down and may be temporarily stored in existing tanks. The produced water is ultimately diverted to an on-site oil / water separator and then to the existing lined evaporation lagoons.

13. Estimated volume of water to be used. Source of water.

The facility uses minimal water that is not produced through the rendering process. Currently, Baker draws approximately 40,000 gallons of water per day from its on-site wells to serve the facility. Based upon maximum boiler capacity and expected actual production rates, additional water use is expected to be less than 8,000 gallons per day.

14. Describe any proposed advertising.

The project will not result in any changes to signage or any other on-site advertising.

15. Will existing buildings be used or new buildings be constructed?

The existing production building will be used, but will be expanded to the north by approximately 870 square feet. The expansion will include walls and roof that are similar in appearance to the existing structure.

16. Explain which buildings will be used in the operation.

The main production building will be expanded by approximately 870 square feet to accommodate the new cooker. The expansion will be constructed of metal and finished compatibly with the existing building.

17. Will any outdoor lighting or sound amplification be used?

The building extension will include outdoor lighting to illuminate the exterior work area. That lighting will replace similar lighting that is attached to the existing exterior north wall of the processing facility. Interior lights will also be installed.

The project does not include sound amplification.

18. Landscaping and Fencing

The project will be constructed in an area that is already in use and already behind facility fences. No additional landscaping or fencing is proposed.

19. Identify Owners, officers and/or Board members for each application submitted.

(previously submitted)

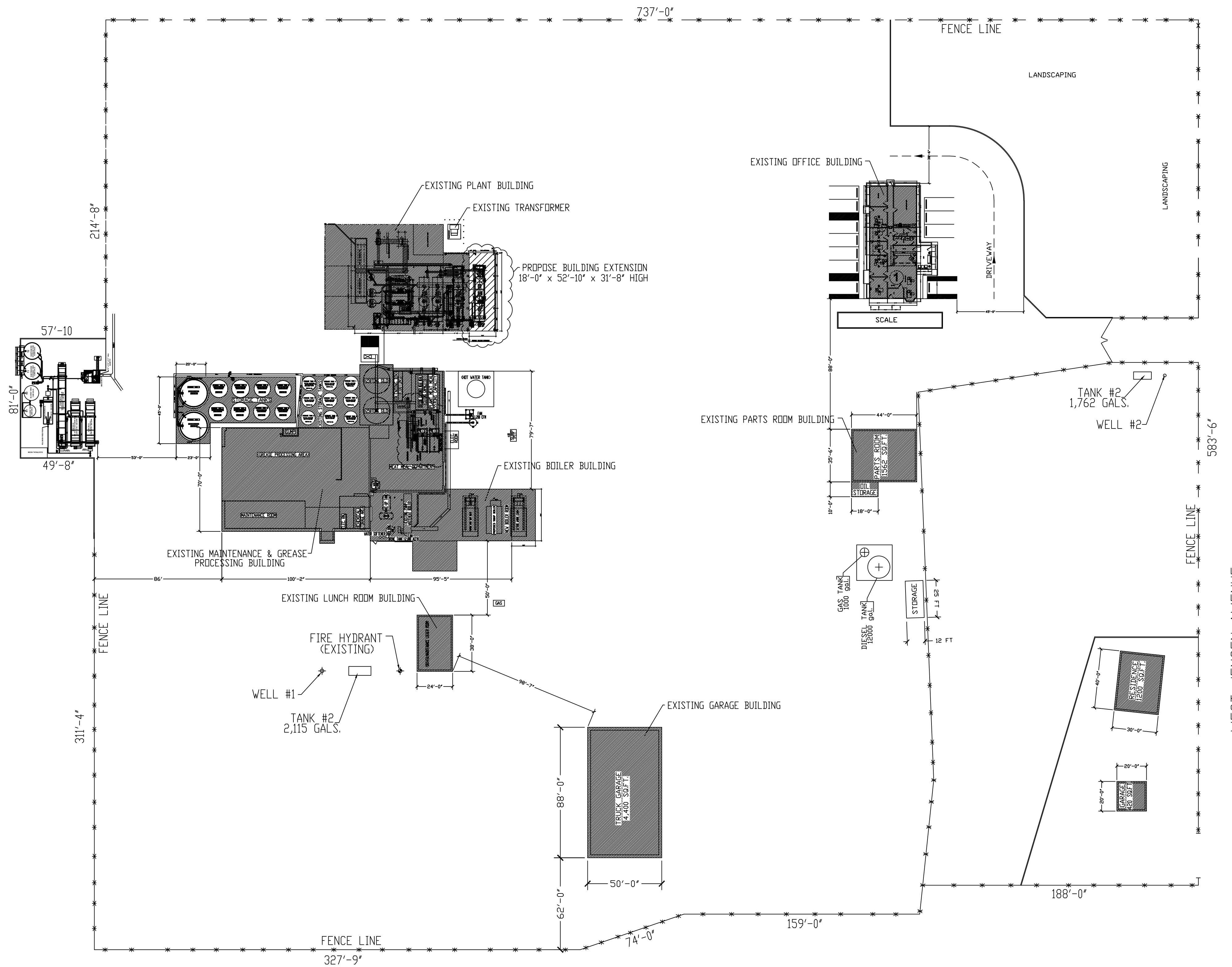
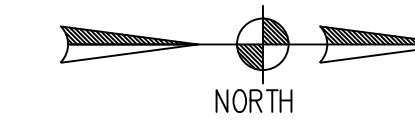

SITE PLAN

REV	DATE	DESCRIPTION
1		
2		
3		
4		
5		
6		
7		

ENGINEER:
DSL STRUCTURAL ENGINEERING, INC.
 10235 TREATHAM AVENUE
 CERRITOS, CALIFORNIA 90703
 TEL. NO. (562) 761-3095

PROJECT TITLE:
PROPOSED 4th COOKER ADDITION
 18001 JENSEN AVENUE
 KERMAN, CALIFORNIA 98300
 TEL. NO. (959) 846-9393

BAKER COMMODITIES, INC.
 KERMAN DIVISION
 18001 JENSEN AVENUE
 KERMAN, CALIFORNIA 98300

DRAWN BY:
 DATE:
12/16/2018
 SCALE:
1" = 40'-0"
 JOB NUMBER:
 DRAWING NUMBER:
A-2

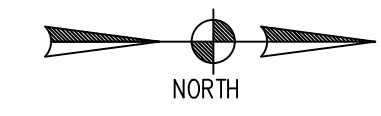
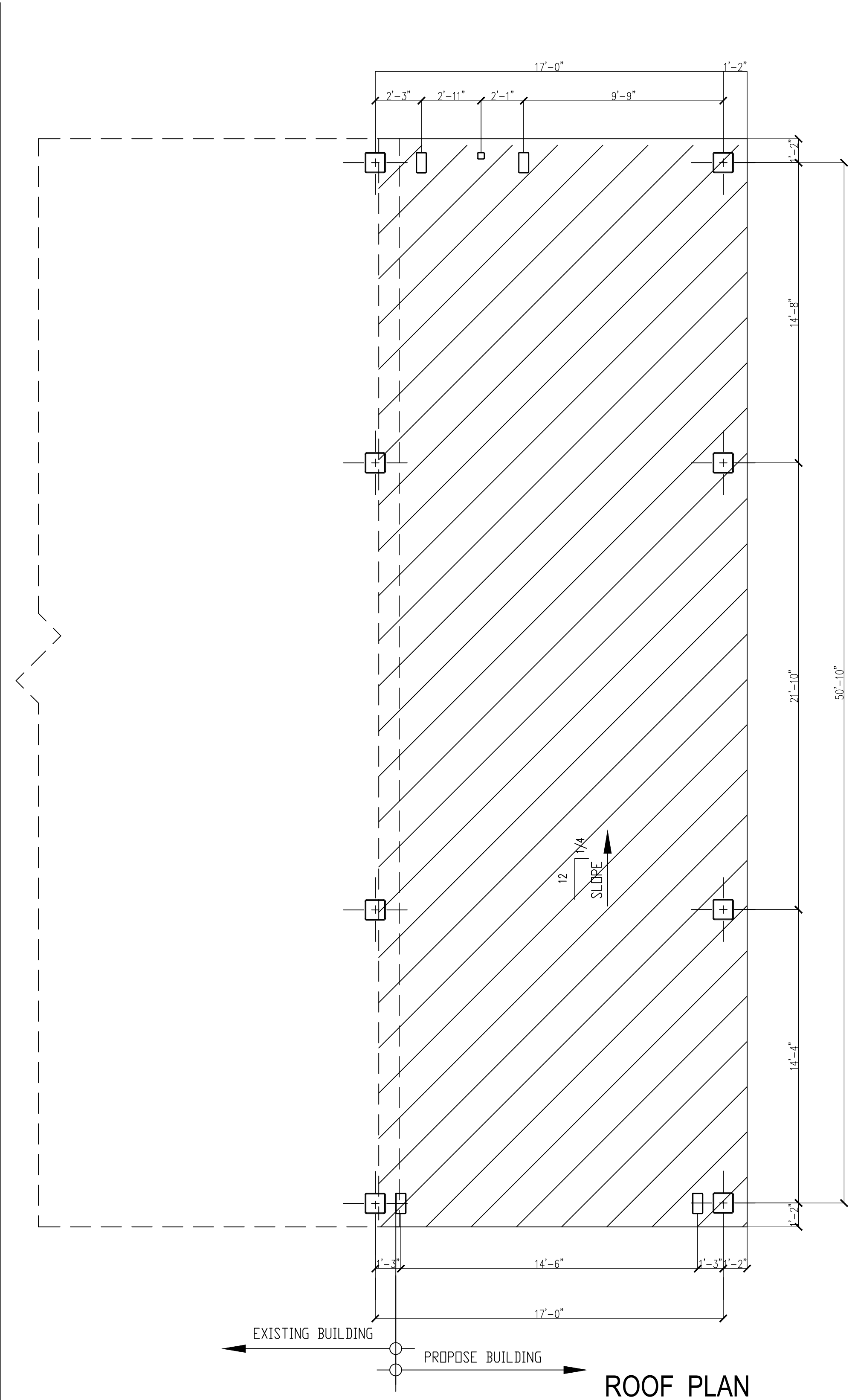
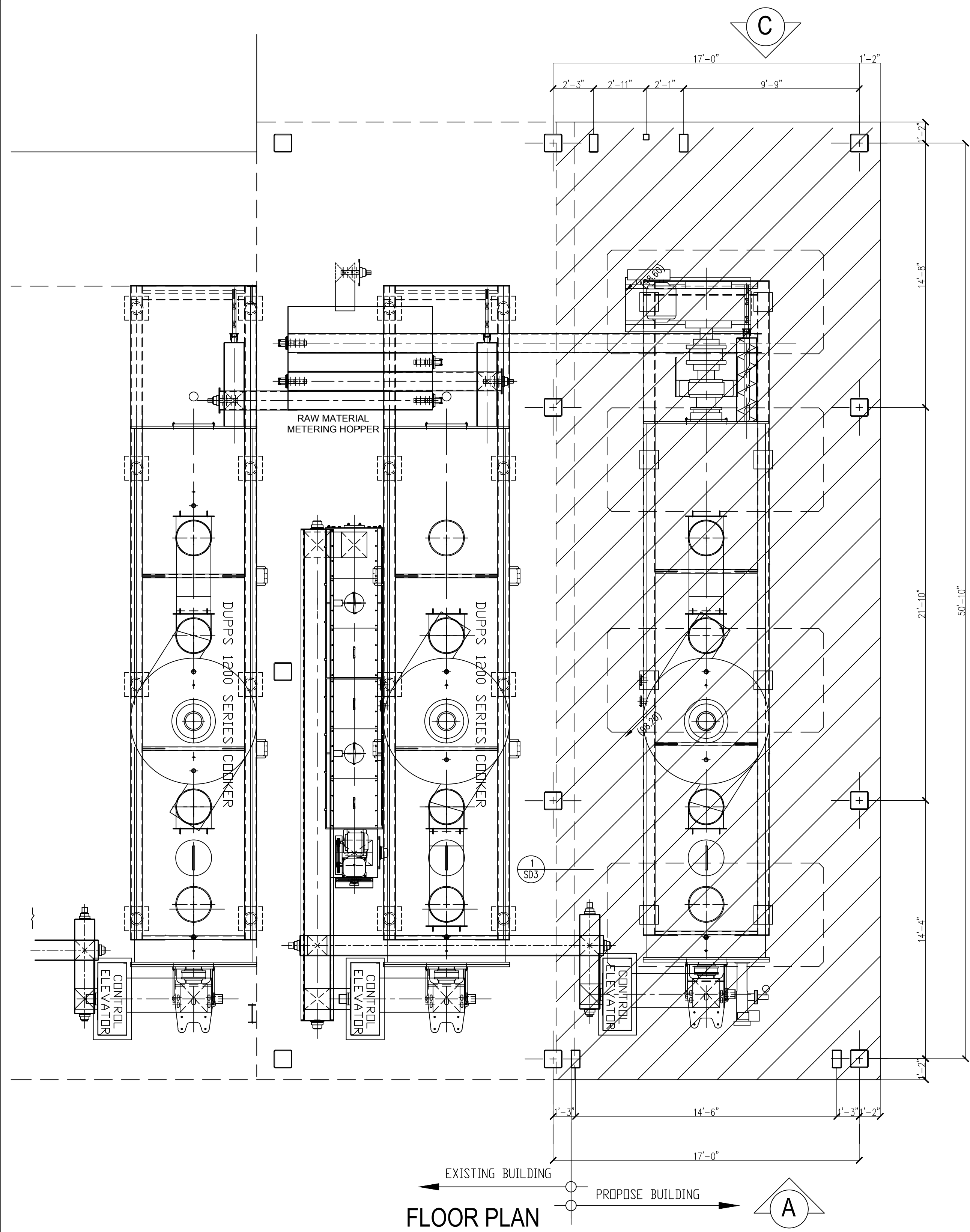

REV	DATE	DESCRIPTION
1		
2		
3		
4		
5		
6		
7		

ENGINEER:
DSL STRUCTURAL ENGINEERING, INC.
 18205 TREATHAM AVENUE
 CERRITOS, CALIFORNIA 90703
 TEL. No. (562) 761-3095

PROJECT TITLE:
PROPOSED 4th COOKER ADDITION
 18804 JENSEN AVENUE
 KERMAN, CALIFORNIA 93330
 TEL. No. (951) 846-9393

BAKER COMMODITIES, INC.
 KERMAN DIVISION
 18804 JENSEN AVENUE
 KERMAN, CALIFORNIA 93330

TITLE:
 DATE:
12/16/2018
 SCALE:
1/4" = 1'-0"
 JOB NUMBER:
 DRAWING NUMBER:
A-3

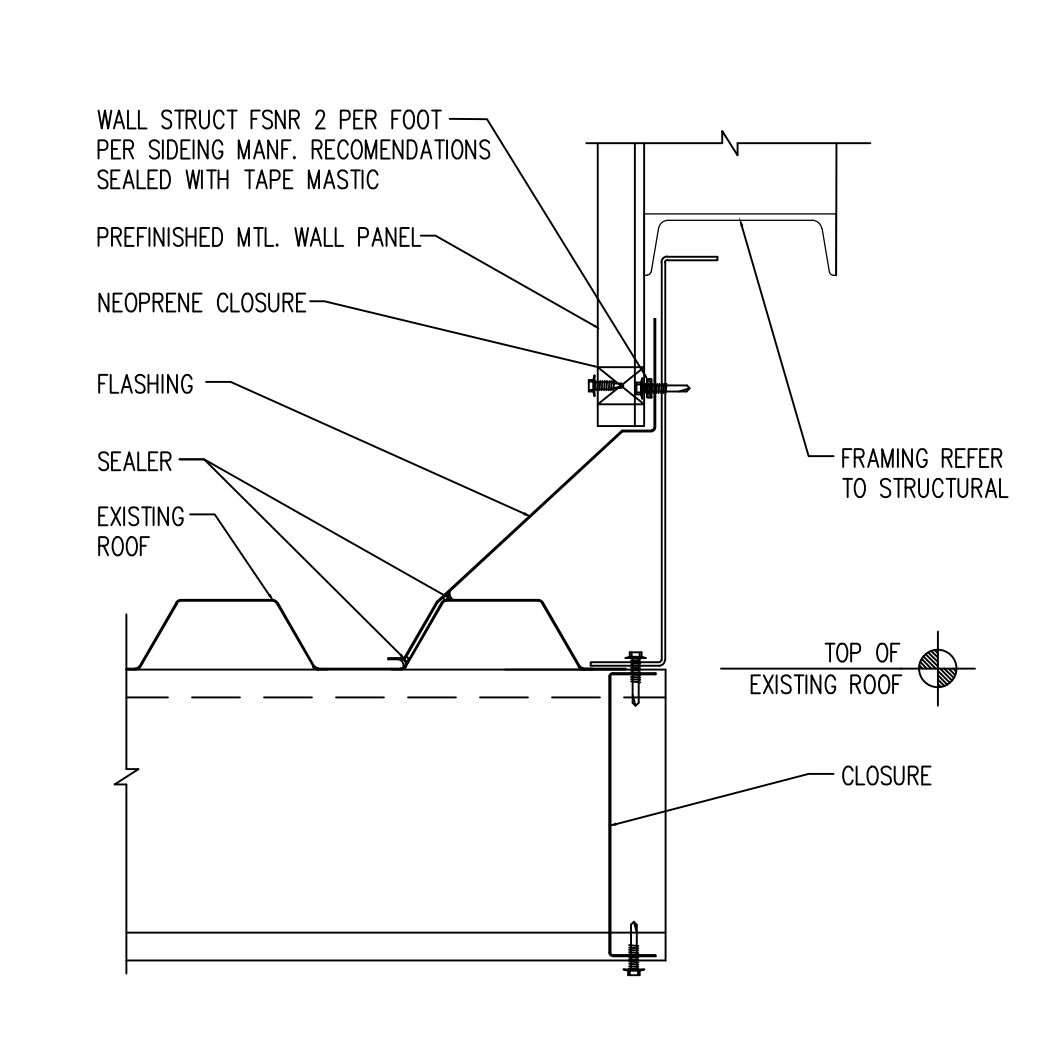
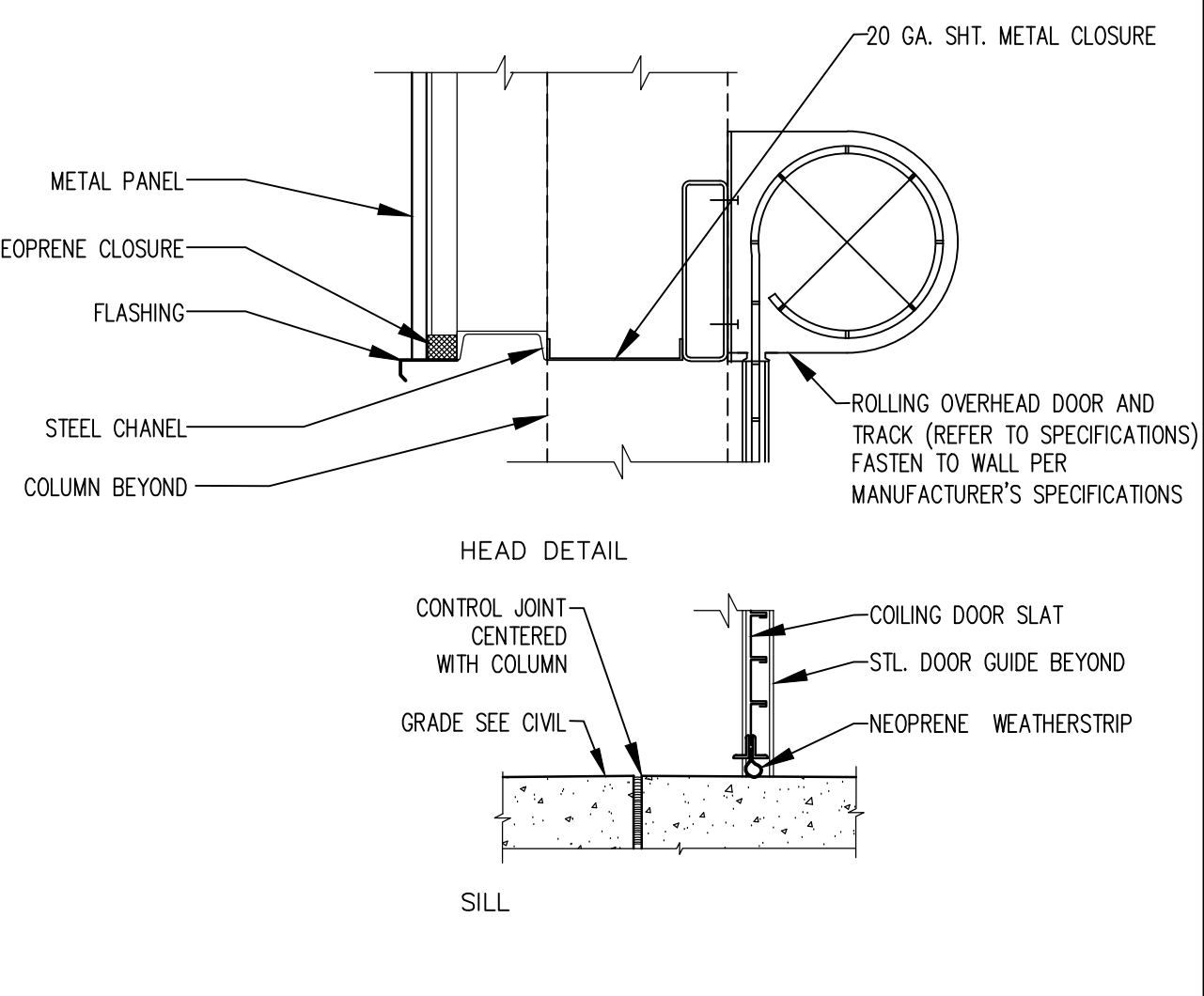
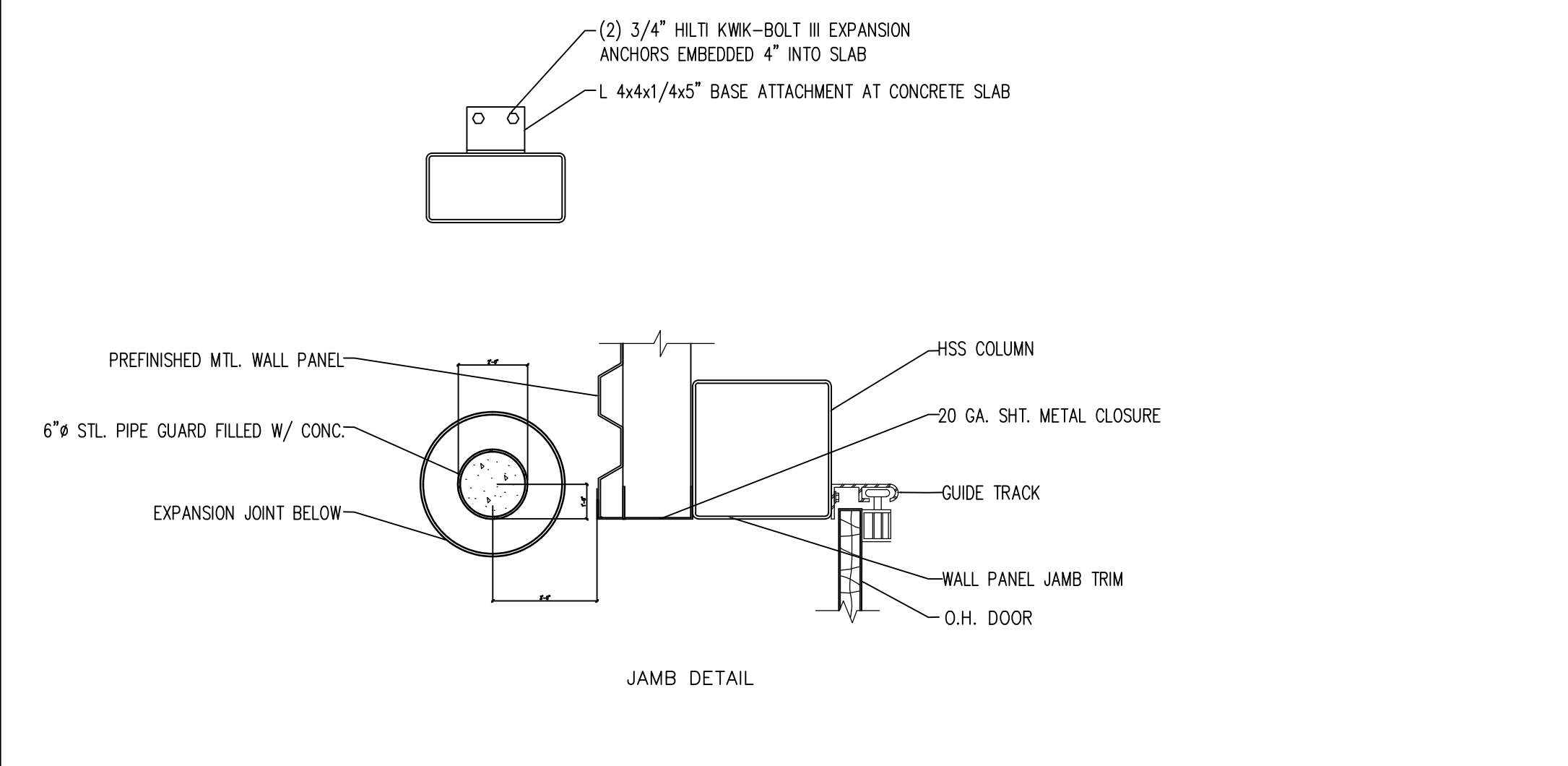

GENERAL NOTES:

THE ROOF STRUCTURE SHALL NOT BE USED FOR STOCKPILING OF EQUIPMENT OR MATERIALS UNLESS APPROVED BY THE ARCHITECT, STRUCTURAL ENGINEER AND THE JOIST MANUFACTURER.

COORDINATE ROOF ELEVATIONS WITH STRUCTURAL DRAWINGS. REFER SPECIFICATION SHEET FOR ROOF RELATED ITEMS, INCLUDING GUARANTEES, CURBS, FLASHING, AND ETC.

REFER TO ROOFING MANUFACTURER'S WRITTEN INSTRUCTIONS AND DETAILS FOR ROOFING SYSTEM INSTALLATION. CONTRACTOR TO PROVIDE COMPLETE ROOFING PACKAGE PER MANUFACTURER'S RECOMMENDATIONS.

KEYED NOTES:

- ① METAL SIDING - SMOOTH FINISH, FACTORY PAINTED TO MATCH EXISTING COLOR
- ② EXPOSED CONCRETE FOUNDATION WALL, SEE STRUCTURAL
- ③ ROOF AND FLASHING - SEE POOF PLAN
- ④ PAINTED METAL SERVICE DOOR AT GRADE
- ⑤ PAINTED ROLL-UP STEEL DOOR
- ⑥ EXISTING STRUCTURE
- ⑦ LINE OF EXISTING ROOF
- ⑧ GRADE
- ⑨ ALL NEW SLAB SHOULD MATCH TO THE EXISTING SLAB.
- ⑩ DIMENSIONS AND ELEVATION SHOULD BE VERIFIED BY A CONTRACTOR ON THE FIELD.

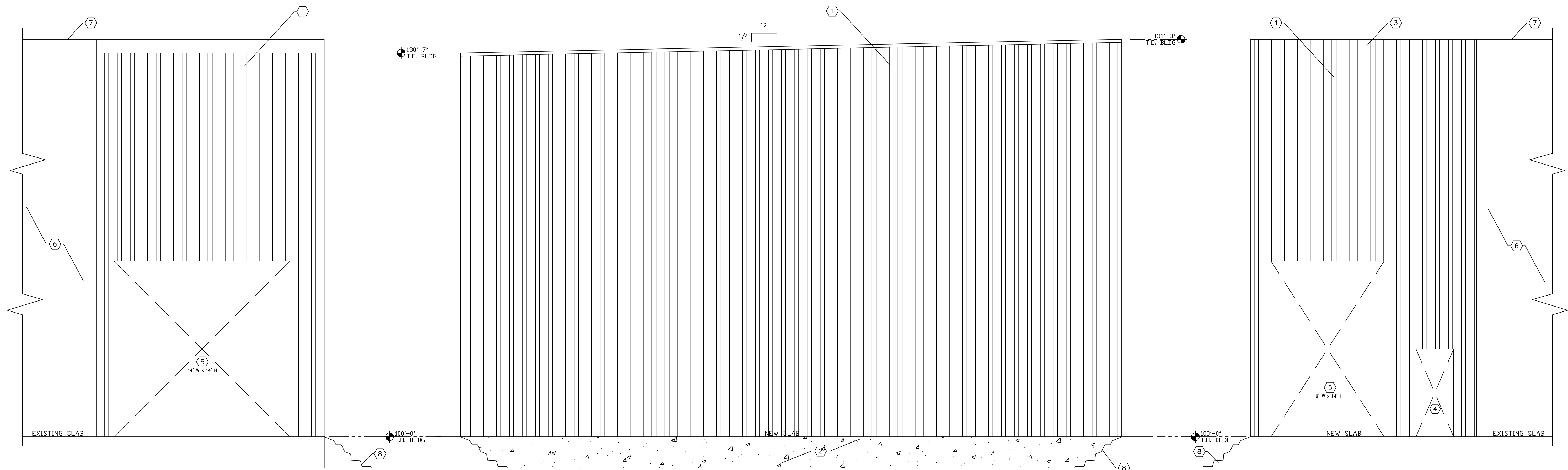

EAST ELEVATION **A**

SOUTH ELEVATION **B**

NORTH ELEVATION **C**

REV	DATE	DESCRIPTION
1		
2		
3		
4		
5		
6		
7		

ENGINEER:
DSL STRUCTURAL ENGINEERING, INC.
 1925 TRENTHAM AVENUE
 CERRITOS, CALIFORNIA 94703
 TEL. No. (662) 797-3095

PROJECT TITLE:
PROPOSED 4th COOKER ADDITION
 16801 JENSEN AVENUE
 KERMAN, CALIFORNIA 98630
 TEL. No. (559) 846-9393

BAKER COMMODITIES, INC.
 KERMAN DIVISION
 16801 JENSEN AVENUE
 KERMAN, CALIFORNIA 98630

TITLE:
 DATE:
 12/16/2018
 SCALE:
 1/4" = 1'-0"
 JOB NUMBER:
 DRAWING NUMBER:
A-4