

POTHOLE REPORT

THIS REPORT IS FOR THE CONTRACTOR'S INFORMATION ONLY. IT IS NOT TO BE CONSIDERED TO BE PART OF THE CONTRACT DOCUMENTS AND SHALL HAVE NO BEARING WHATSOEVER ON THE INTERPRETATION OF THE STANDARD SPECIFICATIONS, THE STANDARD PLANS, THE SPECIAL PROVISIONS, NOR SHALL THEY HAVE ANY BEARING WHATSOEVER ON THE INTERPRETATION OF THE OTHER PUBLICATIONS REFERENCED THEREIN.

TEST HOLE DATA FORM

SUE CREW	EC/DW	 5622 Research Drive, Suite A Huntington Beach, CA 92649 TEL: 714.487.5780 FAX: 714.893.1369	TEST HOLE NUMBER	1
TRUCK NO.	550603		DATE EXCAVATED	8/30/2018
CLIENT PROJECT NO.			LOCATION	HIDALGO AVE/UL4
CARDNO PROJECT NO.	CA12000300		PROJECT	WATER REPLACEMENT
CITY	THREE ROCKS			
COUNTY	FRESNO			

LOCATION PLAN

SECTION VIEW

COORDINATES
 N: _____
 E: _____
 ELE: _____

NOT TO SCALE

DISCLAIMER: ADDITIONAL MATERIAL AND/OR UTILITIES MAY EXIST BELOW APPARENT BOTTOM

ENGLISH/METRIC	ENGLISH	SWING TIES FROM STRUCTURE	APPROX. DISTANCE
SURFACE TYPE		A	
THICKNESS		B	
SOIL CONDITIONS		C	
UTILITY TYPE		UTILITY OWNER:	DATA ENTERED BY:
UTILITY SIZE		DETERMINED BY:	ELIZABETH TURMAN
UTILITY MATERIAL		DESIGNATED:	REVIEWED BY:
MARKET SET			RICHARD HERNANDEZ

REMARKS

DID NOT DO TH-1 DUE TO CLIENT WANTING TH-5 DONE INSTEAD. TH-1 WAS A REPLACEMENT.

NOTE: MATERIAL INDICATED IS BASED ON VISUAL OBSERVATION OF EXPOSED UTILITY. ACTUAL MATERIAL MAY DIFFER

TEST HOLE DATA FORM

SUE CREW	EC/DW	 5622 Research Drive, Suite A Huntington Beach, CA 92649 TEL: 714.487.5780 FAX: 714.893.1369	TEST HOLE NUMBER	2
TRUCK NO.	550603		DATE EXCAVATED	8/30/2018
CLIENT PROJECT NO.	UL-4		LOCATION	
CARDNO PROJECT NO.	CA12000300		HIDALGO AVE/UL4	
CITY	THREE ROCKS		PROJECT	
COUNTY	FRESNO		WATER REPLACEMENT	

LOCATION PLAN



SECTION VIEW

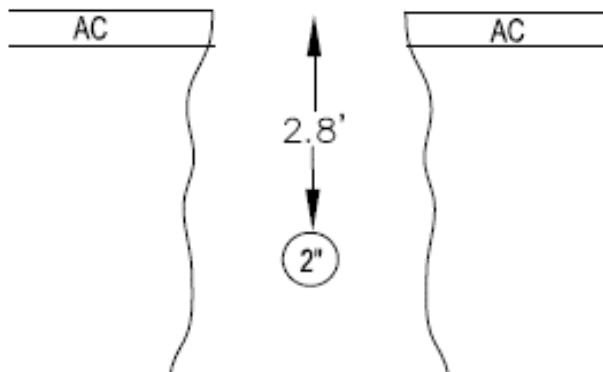

NOT TO SCALE

COORDINATES
 N: _____
 E: _____
 ELE: _____

DISCLAIMER: ADDITIONAL MATERIAL AND/OR UTILITIES MAY EXIST BELOW APPARENT BOTTOM

ENGLISH/METRIC	ENGLISH	SWING TIES FROM STRUCTURE	APPROX. DISTANCE
SURFACE TYPE	AC/AB	A	WATER VALVE 14.60'
THICKNESS	5" / 6"	B	FACE OF CURB 30.40'
SOIL CONDITIONS	DRY SOIL	C	WATER METER 41.20'
UTILITY TYPE	GAS	UTILITY OWNER:	- DATA ENTERED BY:
UTILITY SIZE	2"	DETERMINED BY:	- ELIZABETH TURMAN
UTILITY MATERIAL	METAL	DESIGNATED:	- REVIEWED BY:
MARKET SET	N&D		RICHARD HERNANDEZ

REMARKS

NOTE: MATERIAL INDICATED IS BASED ON VISUAL OBSERVATION OF EXPOSED UTILITY. ACTUAL MATERIAL MAY DIFFER

Before



Utility



Rod



After



TEST HOLE DATA FORM

SUE CREW	EC/DW	 5622 Research Drive, Suite A Huntington Beach, CA 92649 TEL: 714.487.5780 FAX: 714.893.1369	TEST HOLE NUMBER	3
TRUCK NO.	550603		DATE EXCAVATED	8/28/2018
CLIENT PROJECT NO.	UL-4		LOCATION	33194 HIDALGO AVE/UL4
CARDNO PROJECT NO.	CA12000300		PROJECT	WATER REPLACEMENT
CITY	THREE ROCKS			
COUNTY	FRESNO			

LOCATION PLAN



SECTION VIEW

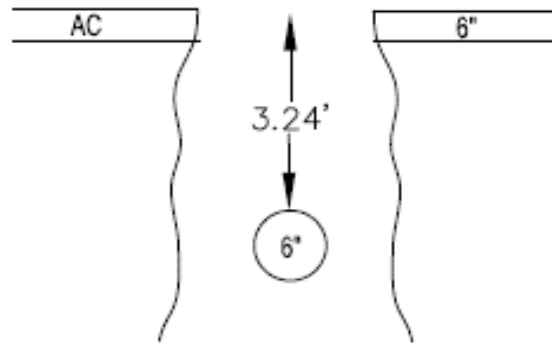

COORDINATES

N: _____

E: _____

ELE: _____

NOT TO SCALE

DISCLAIMER: ADDITIONAL MATERIAL AND/OR UTILITIES MAY EXIST BELOW APPARENT BOTTOM

ENGLISH/METRIC	ENGLISH	SWING TIES FROM STRUCTURE	APPROX. DISTANCE
SURFACE TYPE	AC/AB	A	WATER VALVE 27.00'
THICKNESS	6"	B	FACE OF CURB 18.00'
SOIL CONDITIONS	HARD SOIL	C	WATER METER 33.00'
UTILITY TYPE	WATER	UTILITY OWNER:	- DATA ENTERED BY:
UTILITY SIZE	6"	DETERMINED BY:	- ELIZABETH TURMAN
UTILITY MATERIAL	HDPE	DESIGNATED:	- REVIEWED BY:
MARKET SET	N&D		RICHARD HERNANDEZ

REMARKS

NOTE: MATERIAL INDICATED IS BASED ON VISUAL OBSERVATION OF EXPOSED UTILITY. ACTUAL MATERIAL MAY DIFFER

Before



Utility



Rod



After



TEST HOLE DATA FORM

SUE CREW	EC/DW	 5622 Research Drive, Suite A Huntington Beach, CA 92649 TEL: 714.487.5780 FAX: 714.893.1369	TEST HOLE NUMBER	4
TRUCK NO.	550603		DATE EXCAVATED	8/27/2018
CLIENT PROJECT NO.	UL-4		LOCATION	HIDALGO AVE/UL4
CARDNO PROJECT NO.	CA12000300		PROJECT	WATER REPLACEMENT
CITY	THREE ROCKS			
COUNTY	FRESNO			

LOCATION PLAN



SECTION VIEW

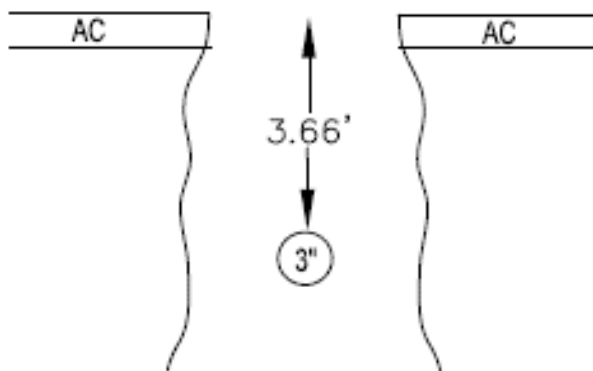

NOT TO SCALE

COORDINATES
 N: _____
 E: _____
 ELE: _____

DISCLAIMER: ADDITIONAL MATERIAL AND/OR UTILITIES MAY EXIST BELOW APPARENT BOTTOM

ENGLISH/METRIC	ENGLISH	SWING TIES FROM STRUCTURE	APPROX. DISTANCE
SURFACE TYPE	AC/AB	A	WATER VALVE 14.00'
THICKNESS	5" / 6"	B	FACE OF CURB 30.90'
SOIL CONDITIONS	DRY SOIL	C	WATER METER 41.20'
UTILITY TYPE	WATER	UTILITY OWNER:	- DATA ENTERED BY:
UTILITY SIZE	3"	DETERMINED BY:	- ELIZABETH TURMAN
UTILITY MATERIAL	PVC	DESIGNATED:	- REVIEWED BY:
MARKET SET	N&D		RICHARD HERNANDEZ

REMARKS

NOTE: MATERIAL INDICATED IS BASED ON VISUAL OBSERVATION OF EXPOSED UTILITY. ACTUAL MATERIAL MAY DIFFER

Before



Utility



Rod



After



TEST HOLE DATA FORM

SUE CREW	EC/DW	 5622 Research Drive, Suite A Huntington Beach, CA 92649 TEL: 714.487.5780 FAX: 714.893.1369	TEST HOLE NUMBER	5
TRUCK NO.	550603		DATE EXCAVATED	8/29/2018
CLIENT PROJECT NO.	UL-4		LOCATION	HIDALGO AVE/UL4
CARDNO PROJECT NO.	CA12000300		PROJECT	WATER REPLACEMENT
CITY	THREE ROCKS			
COUNTY	FRESNO			

LOCATION PLAN



SECTION VIEW

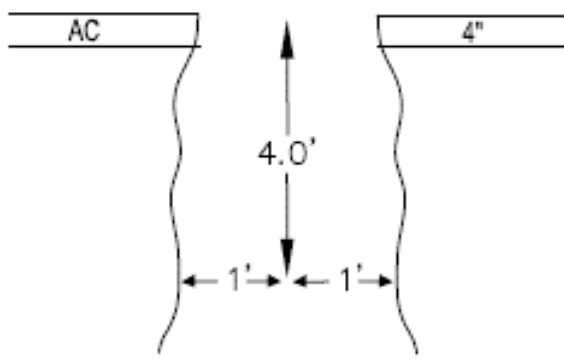

NOT TO SCALE

COORDINATES
 N: _____
 E: _____
 ELE: _____

DISCLAIMER: ADDITIONAL MATERIAL AND/OR UTILITIES MAY EXIST BELOW APPARENT BOTTOM

ENGLISH/METRIC	ENGLISH	SWING TIES FROM STRUCTURE	APPROX. DISTANCE
SURFACE TYPE	AC/AB	A	WATER METER 13.80'
THICKNESS	4"	B	FACE OF CURB 9.30'
SOIL CONDITIONS	CLAY	C	FACE OF CURB 27.80'
UTILITY TYPE	WATER	UTILITY OWNER:	- DATA ENTERED BY:
UTILITY SIZE		DETERMINED BY:	- ELIZABETH TURMAN
UTILITY MATERIAL		DESIGNATED:	- REVIEWED BY:
MARKET SET	N&D		RICHARD HERNANDEZ

REMARKS

OPENED UP TH ON COUNTY WATER MARKS. DOWN TO 4' AND 1' EAST AND WEST. NO UTILITY.

NOTE: MATERIAL INDICATED IS BASED ON VISUAL OBSERVATION OF EXPOSED UTILITY. ACTUAL MATERIAL MAY DIFFER

Before



Utility



Rod



After



TEST HOLE DATA FORM

SUE CREW	EC/DW	 5622 Research Drive, Suite A Huntington Beach, CA 92649 TEL: 714.487.5780 FAX: 714.893.1369	TEST HOLE NUMBER	6
TRUCK NO.	550603		DATE EXCAVATED	8/28/2018
CLIENT PROJECT NO.	UL-3		LOCATION	
CARDNO PROJECT NO.	CA12000300		EL PROGRESSO AVE/UL3	
CITY	THREE ROCKS		PROJECT	
COUNTY	FRESNO		WATER REPLACEMENT	

LOCATION PLAN



SECTION VIEW

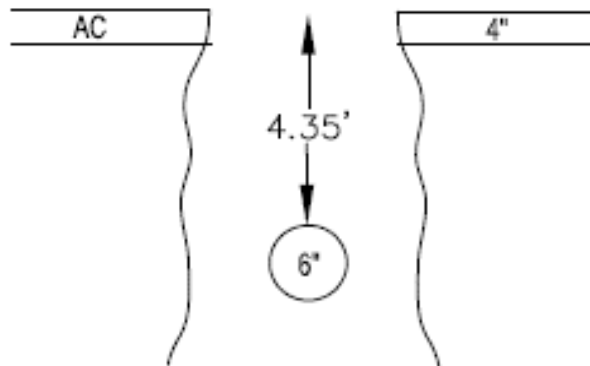

COORDINATES
 N: _____
 E: _____
 ELE: _____

NOT TO SCALE

DISCLAIMER: ADDITIONAL MATERIAL AND/OR UTILITIES MAY EXIST BELOW APPARENT BOTTOM

ENGLISH/METRIC	ENGLISH	SWING TIES FROM STRUCTURE	APPROX. DISTANCE
SURFACE TYPE	AC/AB	A	WATER VALVE 12.10'
THICKNESS	4"	B	FACE OF CURB 18.90'
SOIL CONDITIONS	SAND	C	WATER METER 33.30'
UTILITY TYPE	WATER	UTILITY OWNER:	- DATA ENTERED BY:
UTILITY SIZE	6"	DETERMINED BY:	- ELIZABETH TURMAN
UTILITY MATERIAL	HDPE	DESIGNATED:	- REVIEWED BY:
MARKET SET	N&D		RICHARD HERNANDEZ

REMARKS

OPENED UP TH AND FOUND WATER.

NOTE: MATERIAL INDICATED IS BASED ON VISUAL OBSERVATION OF EXPOSED UTILITY. ACTUAL MATERIAL MAY DIFFER

Before



Utility



Rod



After



TEST HOLE DATA FORM

SUE CREW	EC/DW	 5622 Research Drive, Suite A Huntington Beach, CA 92649 TEL: 714.487.5780 FAX: 714.893.1369	TEST HOLE NUMBER	6.1
TRUCK NO.	550603		DATE EXCAVATED	8/28/2018
CLIENT PROJECT NO.	UL-3		LOCATION	
CARDNO PROJECT NO.	CA12000300		EL PROGRESSO AVE/UL3	
CITY	THREE ROCKS		PROJECT	
COUNTY	FRESNO		WATER REPLACEMENT	

LOCATION PLAN



SECTION VIEW

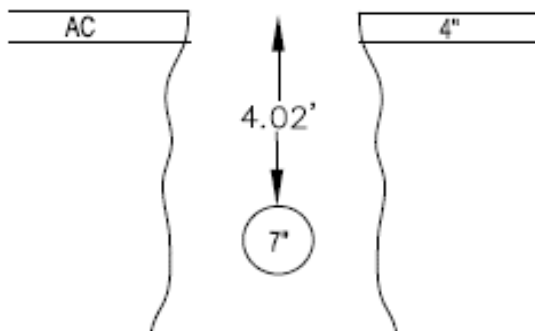

COORDINATES
 N: _____
 E: _____
 ELE: _____

NOT TO SCALE

DISCLAIMER: ADDITIONAL MATERIAL AND/OR UTILITIES MAY EXIST BELOW APPARENT BOTTOM

ENGLISH/METRIC	ENGLISH	SWING TIES FROM STRUCTURE	APPROX. DISTANCE
SURFACE TYPE	AC/AB	A	WATER VALVE 11.00'
THICKNESS	40	B	FACE OF CURB 19.70'
SOIL CONDITIONS	SAND	C	WATER METER 34.20'
UTILITY TYPE	SEWER	UTILITY OWNER:	- DATA ENTERED BY:
UTILITY SIZE	7"	DETERMINED BY:	- ELIZABETH TURMAN
UTILITY MATERIAL	VCP	DESIGNATED:	- REVIEWED BY:
MARKET SET	N&D		RICHARD HERNANDEZ

REMARKS

NOTE: MATERIAL INDICATED IS BASED ON VISUAL OBSERVATION OF EXPOSED UTILITY. ACTUAL MATERIAL MAY DIFFER

Before



Utility



Rod

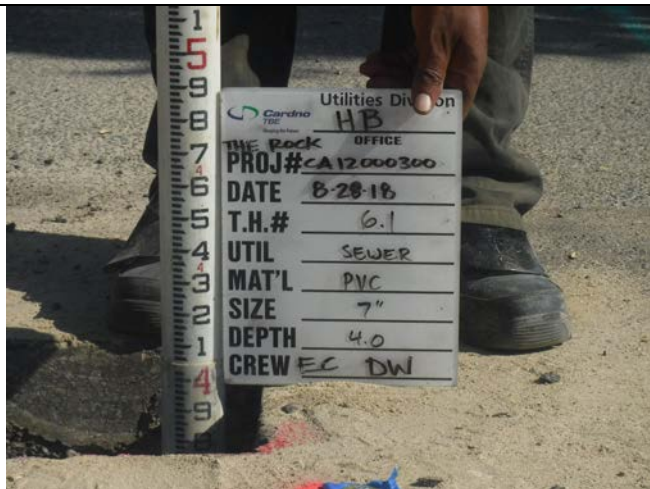

After



TEST HOLE DATA FORM

SUE CREW	EC/DW	 5622 Research Drive, Suite A Huntington Beach, CA 92649 TEL: 714.487.5780 FAX: 714.893.1369	TEST HOLE NUMBER	7
TRUCK NO.	550603		DATE EXCAVATED	8/28/2018
CLIENT PROJECT NO.	UL-3		LOCATION	
CARDNO PROJECT NO.	CA12000300		EL PROGRESSO AVE/UL3	
CITY	THREE ROCKS		PROJECT	
COUNTY	FRESNO		WATER REPLACEMENT	

LOCATION PLAN



SECTION VIEW

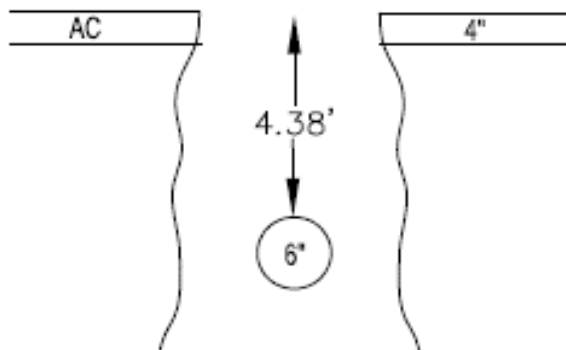

COORDINATES
 N: _____
 E: _____
 ELE: _____

NOT TO SCALE

DISCLAIMER: ADDITIONAL MATERIAL AND/OR UTILITIES MAY EXIST BELOW APPARENT BOTTOM

ENGLISH/METRIC	ENGLISH	SWING TIES FROM STRUCTURE	APPROX. DISTANCE
SURFACE TYPE	AC/AB	A	WATER VALVE 12.90'
THICKNESS	5"	B	FACE OF CURB 19.11'
SOIL CONDITIONS	SAND	C	WATER METER 29.80'
UTILITY TYPE	SEWER	UTILITY OWNER:	- DATA ENTERED BY:
UTILITY SIZE	6"	DETERMINED BY:	- ELIZABETH TURMAN
UTILITY MATERIAL	HDPE	DESIGNATED:	- REVIEWED BY:
MARKET SET	N&D		RICHARD HERNANDEZ

REMARKS

OPENED UP TH 2' WEST OF SS MARKS AS PER CLIENT REQUEST. CLEARED DOWN TO 6'. NO UTILITY SO IN TH-6 WE WENT EAST AND FOUND ABANDONED SEWER LINE SO WE WENT MORE WEST AND FOUND UTILITY 6.8' WEST OF SEWER. USA MARKS NOT 2' AS PER PLAN.

NOTE: MATERIAL INDICATED IS BASED ON VISUAL OBSERVATION OF EXPOSED UTILITY. ACTUAL MATERIAL MAY DIFFER

Before



Utility



Rod



After



TEST HOLE DATA FORM

SUE CREW	EC/DW	 5622 Research Drive, Suite A Huntington Beach, CA 92649 TEL: 714.487.5780 FAX: 714.893.1369	TEST HOLE NUMBER	8
TRUCK NO.	550603		DATE EXCAVATED	8/29/2018
CLIENT PROJECT NO.	UL-2		LOCATION	
CARDNO PROJECT NO.	CA12000300		JUAREZ AVE/UL2	
CITY	THREE ROCKS		PROJECT	
COUNTY	FRESNO		WATER REPLACEMENT	

LOCATION PLAN



SECTION VIEW

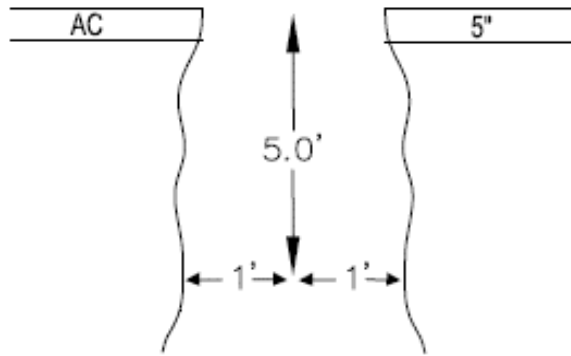

NOT TO SCALE

COORDINATES
 N: _____
 E: _____
 ELE: _____

DISCLAIMER: ADDITIONAL MATERIAL AND/OR UTILITIES MAY EXIST BELOW APPARENT BOTTOM

ENGLISH/METRIC	ENGLISH	SWING TIES FROM STRUCTURE	APPROX. DISTANCE
SURFACE TYPE	AC/AB	A	WATER METER 27.70'
THICKNESS	5"	B	PULL BOX 45.00'
SOIL CONDITIONS	CLAY	C	SDCB 52.60'
UTILITY TYPE	WATER	UTILITY OWNER:	- DATA ENTERED BY:
UTILITY SIZE	6"	DETERMINED BY:	- ELIZABETH TURMAN
UTILITY MATERIAL		DESIGNATED:	- REVIEWED BY:
MARKET SET			RICHARD HERNANDEZ

REMARKS

OPENED UP TH AND CLEARED DOWN TO 5'. NO UTILITY. USED CHISEL AND HAND AUGUR TO CLEAR.

NOTE: MATERIAL INDICATED IS BASED ON VISUAL OBSERVATION OF EXPOSED UTILITY. ACTUAL MATERIAL MAY DIFFER

Before



Utility



Rod



After



TEST HOLE DATA FORM

SUE CREW	EC/DW	 5622 Research Drive, Suite A Huntington Beach, CA 92649 TEL: 714.487.5780 FAX: 714.893.1369	TEST HOLE NUMBER	8A
TRUCK NO.	550603		DATE EXCAVATED	8/29/2018
CLIENT PROJECT NO.	UL-2		LOCATION	
CARDNO PROJECT NO.	CA12000300		JUAREZ AVE/UL2	
CITY	THREE ROCKS		PROJECT	
COUNTY	FRESNO		WATER REPLACEMENT	

LOCATION PLAN



SECTION VIEW

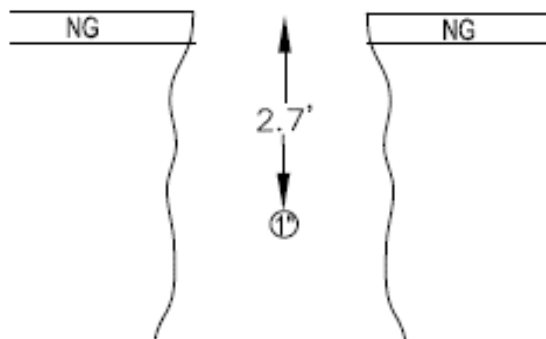

COORDINATES
 N: _____
 E: _____
 ELE: _____

NOT TO SCALE

DISCLAIMER: ADDITIONAL MATERIAL AND/OR UTILITIES MAY EXIST BELOW APPARENT BOTTOM

ENGLISH/METRIC	ENGLISH	SWING TIES FROM STRUCTURE	APPROX. DISTANCE
SURFACE TYPE	N G	A	WATER METER 3.40'
THICKNESS		B	PULL BOX 47.00'
SOIL CONDITIONS	CLAY	C	SDCB 69.00'
UTILITY TYPE	WATER	UTILITY OWNER:	- DATA ENTERED BY:
UTILITY SIZE	1"	DETERMINED BY:	- ELIZABETH TURMAN
UTILITY MATERIAL	HDPE	DESIGNATED:	- REVIEWED BY:
MARKET SET	N & W		RICHARD HERNANDEZ

REMARKS

OPENED UP TH TO LOCATE DEPTH OF LATERAL.

NOTE: MATERIAL INDICATED IS BASED ON VISUAL OBSERVATION OF EXPOSED UTILITY. ACTUAL MATERIAL MAY DIFFER

Before



Utility



Rod



After



TEST HOLE DATA FORM

SUE CREW	EC/DW	 5622 Research Drive, Suite A Huntington Beach, CA 92649 TEL: 714.487.5780 FAX: 714.893.1369	TEST HOLE NUMBER	9
TRUCK NO.	550603		DATE EXCAVATED	8/29/2018
CLIENT PROJECT NO.	UL-2		LOCATION	JUAREZ AVE/UL2
CARDNO PROJECT NO.	CA12000300		PROJECT	WATER REPLACEMENT
CITY	THREE ROCKS			
COUNTY	FRESNO			

LOCATION PLAN



SECTION VIEW

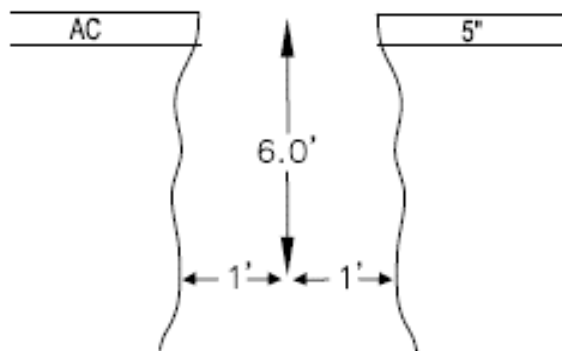

NOT TO SCALE

COORDINATES
 N: _____
 E: _____
 ELE: _____

DISCLAIMER: ADDITIONAL MATERIAL AND/OR UTILITIES MAY EXIST BELOW APPARENT BOTTOM

ENGLISH/METRIC	ENGLISH	SWING TIES FROM STRUCTURE	APPROX. DISTANCE
SURFACE TYPE	AC/AB	A	WATER METER 38.00'
THICKNESS	5"	B	PULL BOX 54.30'
SOIL CONDITIONS	CLAY	C	SDCB 54.50'
UTILITY TYPE	WATER	UTILITY OWNER:	- DATA ENTERED BY:
UTILITY SIZE		DETERMINED BY:	- ELIZABETH TURMAN
UTILITY MATERIAL		DESIGNATED:	- REVIEWED BY:
MARKET SET			RICHARD HERNANDEZ

REMARKS

OPENED UP TH ON USA DURE TO NO SIGNAL CLEARED DOWN TO 6FT AND 1' NORTH AND SOUTH. NO UTILITY. RON FROM COUNTY WATER CAME OUT AND REMARKED UTILITY. SEE TH 9A FOR INFO.

NOTE: MATERIAL INDICATED IS BASED ON VISUAL OBSERVATION OF EXPOSED UTILITY. ACTUAL MATERIAL MAY DIFFER

Before



Utility



Rod



After



TEST HOLE DATA FORM

SUE CREW	EC/DW	 5622 Research Drive, Suite A Huntington Beach, CA 92649 TEL: 714.487.5780 FAX: 714.893.1369	TEST HOLE NUMBER	9A
TRUCK NO.	550603		DATE EXCAVATED	8/29/2018
CLIENT PROJECT NO.	UL-2		LOCATION	
CARDNO PROJECT NO.	CA12000300		JUAREZ AVE/UL2	
CITY	THREE ROCKS		PROJECT	
COUNTY	FRESNO		WATER REPLACEMENT	

LOCATION PLAN



SECTION VIEW

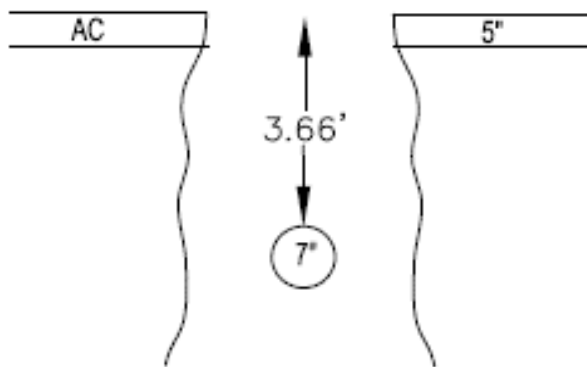

COORDINATES
 N: _____
 E: _____
 ELE: _____

NOT TO SCALE

DISCLAIMER: ADDITIONAL MATERIAL AND/OR UTILITIES MAY EXIST BELOW APPARENT BOTTOM

ENGLISH/METRIC	ENGLISH	SWING TIES FROM STRUCTURE	APPROX. DISTANCE
SURFACE TYPE	AC/AB	A	WATER METER 35.40'
THICKNESS	5"	B	PULL BOX 50.00'
SOIL CONDITIONS	CLAY	C	SDCB 51.90'
UTILITY TYPE	WATER	UTILITY OWNER:	- DATA ENTERED BY:
UTILITY SIZE	7"	DETERMINED BY:	- ELIZABETH TURMAN
UTILITY MATERIAL	ACP	DESIGNATED:	- REVIEWED BY:
MARKET SET	N & D		RICHARD HERNANDEZ

REMARKS

OPENED UP TH 9A DUE TO NEW WATER MARKS BY COUNTY WATER REP, RON.

NOTE: MATERIAL INDICATED IS BASED ON VISUAL OBSERVATION OF EXPOSED UTILITY. ACTUAL MATERIAL MAY DIFFER

Before



Utility



Rod



After



TEST HOLE DATA FORM

SUE CREW	EC/DW	 5622 Research Drive, Suite A Huntington Beach, CA 92649 TEL: 714.487.5780 FAX: 714.893.1369	TEST HOLE NUMBER	9B
TRUCK NO.	550603		DATE EXCAVATED	8/30/2018
CLIENT PROJECT NO.	UL-2		LOCATION	JUAREZ AVE/UL2
CARDNO PROJECT NO.	CA12000300		PROJECT	WATER REPLACEMENT
CITY	THREE ROCKS			
COUNTY	FRESNO			

LOCATION PLAN



SECTION VIEW

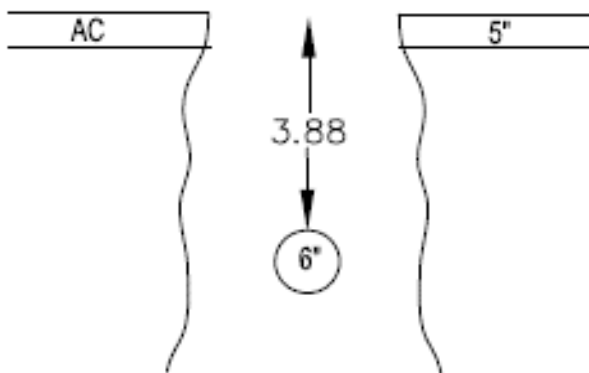

NOT TO SCALE

COORDINATES
 N: _____
 E: _____
 ELE: _____

DISCLAIMER: ADDITIONAL MATERIAL AND/OR UTILITIES MAY EXIST BELOW APPARENT BOTTOM

ENGLISH/METRIC	ENGLISH	SWING TIES FROM STRUCTURE	APPROX. DISTANCE
SURFACE TYPE	AC/AB	A	WATER METER 30.50'
THICKNESS	5"	B	PULL BOX 47.40'
SOIL CONDITIONS	CLAY	C	SDCB 52.80'
UTILITY TYPE	WATER	UTILITY OWNER:	- DATA ENTERED BY:
UTILITY SIZE	6"	DETERMINED BY:	- ELIZABETH TURMAN
UTILITY MATERIAL	HDPE	DESIGNATED:	- REVIEWED BY:
MARKET SET	N & D		RICHARD HERNANDEZ

REMARKS

AFTER NOT FINDING UTILITY ON USA MARKS, WE TRIED TO LOCATE CONNECTING TO FIRE HYDRANT AND FOUND NO SIGNAL. WE THEN OPENED W/V AND SAW TRACER WIRE THAT WE DIDN'T HAVE IN OTHER VALVES. CONNECTED TO IT AND TRACED OUT TO PUMP STATION AND NORTH WEST TO HIDALGO.

NOTE: MATERIAL INDICATED IS BASED ON VISUAL OBSERVATION OF EXPOSED UTILITY. ACTUAL MATERIAL MAY DIFFER

Before



Utility



Rod



After



TEST HOLE DATA FORM

SUE CREW	EC/DW	 5622 Research Drive, Suite A Huntington Beach, CA 92649 TEL: 714.487.5780 FAX: 714.893.1369	TEST HOLE NUMBER	10
TRUCK NO.	550603		DATE EXCAVATED	8/29/2018
CLIENT PROJECT NO.	UL-2		LOCATION	JUAREZ AVE/UL2
CARDNO PROJECT NO.	CA12000300		PROJECT	WATER REPLACEMENT
CITY	THREE ROCKS			
COUNTY	FRESNO			

LOCATION PLAN

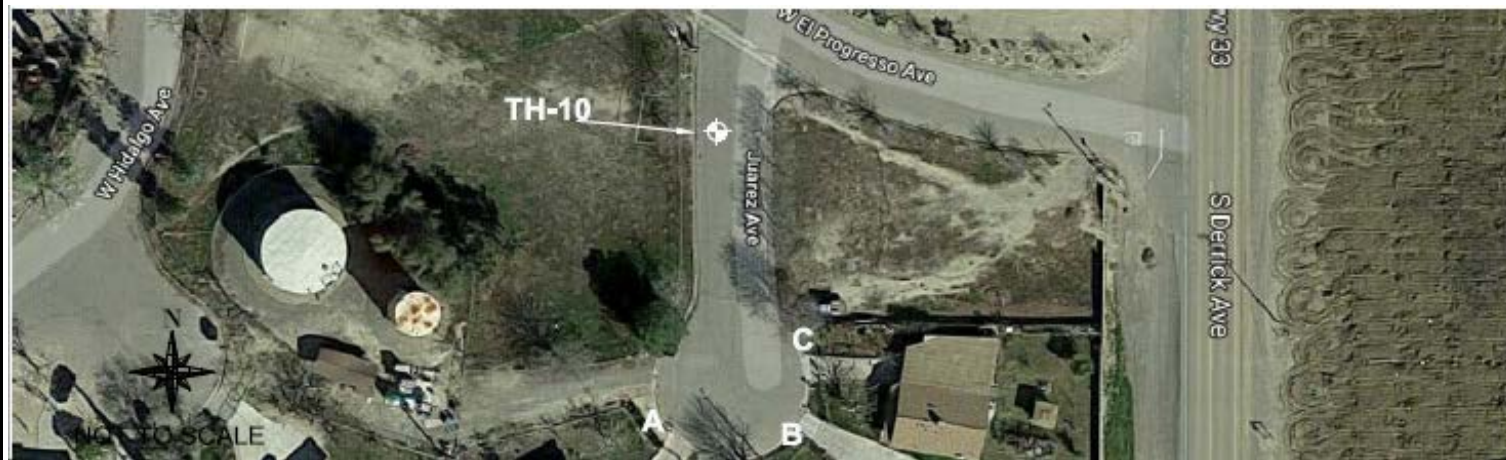

SECTION VIEW

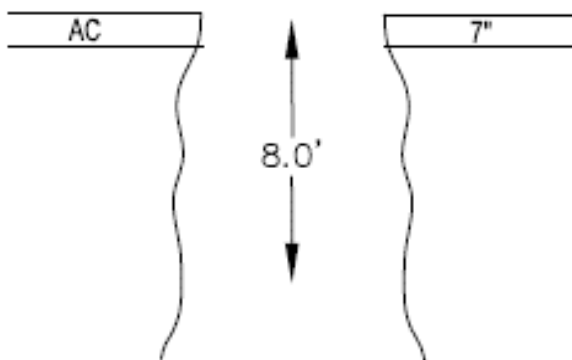

NOT TO SCALE

COORDINATES
 N: _____
 E: _____
 ELE: _____

DISCLAIMER: ADDITIONAL MATERIAL AND/OR UTILITIES MAY EXIST BELOW APPARENT BOTTOM

ENGLISH/METRIC	ENGLISH	SWING TIES FROM STRUCTURE	APPROX. DISTANCE
SURFACE TYPE	AC/AB	A	WATER METER 70.00'
THICKNESS	7"	B	PULL BOX 60.70'
SOIL CONDITIONS	CLAY/DRY SOIL	C	SDCB 36.70'
UTILITY TYPE	RAW WATER	UTILITY OWNER:	- DATA ENTERED BY:
UTILITY SIZE		DETERMINED BY:	- ELIZABETH TURMAN
UTILITY MATERIAL		DESIGNATED:	- REVIEWED BY:
MARKET SET			RICHARD HERNANDEZ

REMARKS

OPENED UP TH ON USA MARKS AND CLEARED DOWN TO 8.0FT NO RAW WATER UTILITY FOUND. HAD TO USE CHISEL AND HAND AUGER TO CLEAR DOWN.

NOTE: MATERIAL INDICATED IS BASED ON VISUAL OBSERVATION OF EXPOSED UTILITY. ACTUAL MATERIAL MAY DIFFER

Before



Utility



Rod



After



TEST HOLE DATA FORM

SUE CREW	EC/DW	 5622 Research Drive, Suite A Huntington Beach, CA 92649 TEL: 714.487.5780 FAX: 714.893.1369	TEST HOLE NUMBER	10A
TRUCK NO.	550603		DATE EXCAVATED	8/30/2018
CLIENT PROJECT NO.	UL-1		LOCATION	JUAREZ AVE/UL1
CARDNO PROJECT NO.	CA12000300		PROJECT	WATER REPLACEMENT
CITY	THREE ROCKS			
COUNTY	FRESNO			

LOCATION PLAN



SECTION VIEW

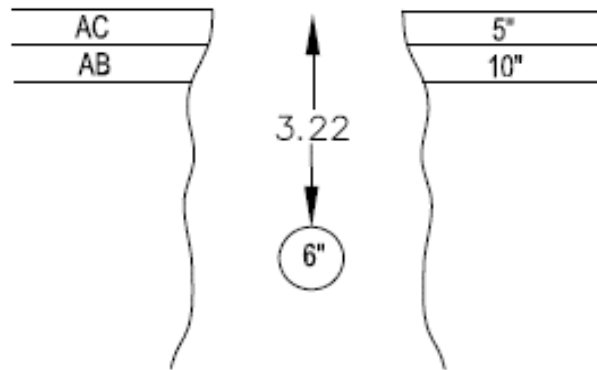

NOT TO SCALE

COORDINATES
 N: _____
 E: _____
 ELE: _____

DISCLAIMER: ADDITIONAL MATERIAL AND/OR UTILITIES MAY EXIST BELOW APPARENT BOTTOM

ENGLISH/METRIC	ENGLISH	SWING TIES FROM STRUCTURE	APPROX. DISTANCE
SURFACE TYPE	AC/AB	A	FACE OF CURB 23.40'
THICKNESS	5"/10"	B	EDGE OF GUTTER 10.86'
SOIL CONDITIONS	CLAY	C	WATER VALVE 20.60'
UTILITY TYPE	RAW WATER	UTILITY OWNER:	- DATA ENTERED BY:
UTILITY SIZE	6"	DETERMINED BY:	- ELIZABETH TURMAN
UTILITY MATERIAL	PVC	DESIGNATED:	- REVIEWED BY:
MARKET SET	N & D		RICHARD HERNANDEZ

REMARKS

NOTE: MATERIAL INDICATED IS BASED ON VISUAL OBSERVATION OF EXPOSED UTILITY. ACTUAL MATERIAL MAY DIFFER

Before



Utility



Rod



After



TEST HOLE DATA FORM

SUE CREW	EC/DW	 5622 Research Drive, Suite A Huntington Beach, CA 92649 TEL: 714.487.5780 FAX: 714.893.1369	TEST HOLE NUMBER	11
TRUCK NO.	550603		DATE EXCAVATED	8/30/2018
CLIENT PROJECT NO.	UL-1		LOCATION	
CARDNO PROJECT NO.	CA12000300		JUAREZ AVE/UL1	
CITY	THREE ROCKS		PROJECT	
COUNTY	FRESNO		WATER REPLACEMENT	

LOCATION PLAN



SECTION VIEW

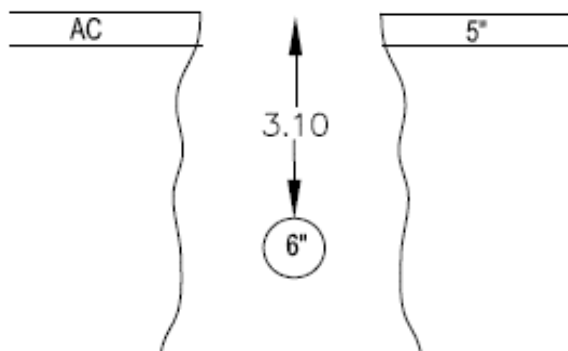

COORDINATES
 N: _____
 E: _____
 ELE: _____

NOT TO SCALE

DISCLAIMER: ADDITIONAL MATERIAL AND/OR UTILITIES MAY EXIST BELOW APPARENT BOTTOM

ENGLISH/METRIC	ENGLISH	SWING TIES FROM STRUCTURE	APPROX. DISTANCE
SURFACE TYPE	AC/AB	A	FACE OF CURB 18.10'
THICKNESS	5"	B	EDGE OF GUTTER 16.20'
SOIL CONDITIONS	CLAY	C	WATER VALVE 20.60'
UTILITY TYPE	WATER	UTILITY OWNER:	- DATA ENTERED BY:
UTILITY SIZE	6"	DETERMINED BY:	- ELIZABETH TURMAN
UTILITY MATERIAL	HDPE	DESIGNATED:	- REVIEWED BY:
MARKET SET	N & D		RICHARD HERNANDEZ

REMARKS

NOTE: MATERIAL INDICATED IS BASED ON VISUAL OBSERVATION OF EXPOSED UTILITY. ACTUAL MATERIAL MAY DIFFER

Before



Utility



Rod



After



TEST HOLE DATA FORM

SUE CREW	EC/DW	 5622 Research Drive, Suite A Huntington Beach, CA 92649 TEL: 714.487.5780 FAX: 714.893.1369	TEST HOLE NUMBER	12
TRUCK NO.	550603		DATE EXCAVATED	8/30/2018
CLIENT PROJECT NO.	UL-1		LOCATION	DOMENGINE AVE & W HIDALGO/UL1
CARDNO PROJECT NO.	CA12000300		PROJECT	WATER REPLACEMENT
CITY	CANTUA CREEK			
COUNTY	FRESNO			

LOCATION PLAN



SECTION VIEW

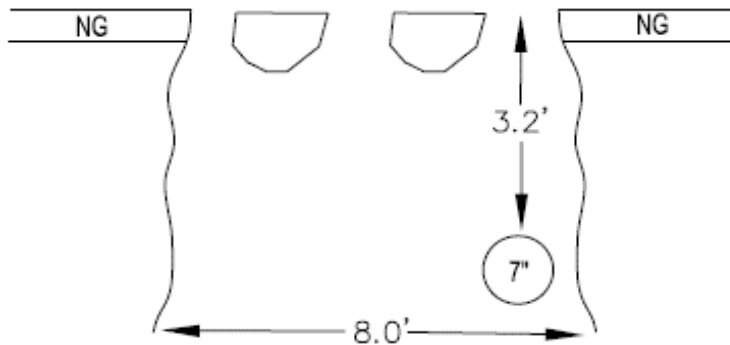

COORDINATES
 N: _____
 E: _____
 ELE: _____

NOT TO SCALE

DISCLAIMER: ADDITIONAL MATERIAL AND/OR UTILITIES MAY EXIST BELOW APPARENT BOTTOM

ENGLISH/METRIC	ENGLISH	SWING TIES FROM STRUCTURE	APPROX. DISTANCE
SURFACE TYPE	NG	A	WATER VALVE 9.30'
THICKNESS		B	WATER VALVE 12.00'
SOIL CONDITIONS	CLAY	C	
UTILITY TYPE	WATER	UTILITY OWNER:	- DATA ENTERED BY:
UTILITY SIZE	7"	DETERMINED BY:	- ELIZABETH TURMAN
UTILITY MATERIAL	ACD	DESIGNATED:	- REVIEWED BY:
MARKET SET	R & W		RICHARD HERNANDEZ

REMARKS

OPENED UP TH ON USA MARK. CLEARED DOWN TO 5'. NO UTILITY FOUND. TRACED WEST AND FOUND UTILITY.

NOTE: MATERIAL INDICATED IS BASED ON VISUAL OBSERVATION OF EXPOSED UTILITY. ACTUAL MATERIAL MAY DIFFER

Before



Utility



Rod



After



TEST HOLE DATA FORM

SUE CREW	EC/DW	 5622 Research Drive, Suite A Huntington Beach, CA 92649 TEL: 714.487.5780 FAX: 714.893.1369	TEST HOLE NUMBER	13
TRUCK NO.	550603		DATE EXCAVATED	8/30/2018
CLIENT PROJECT NO.	UL-2		LOCATION	
CARDNO PROJECT NO.	CA12000300		DOMENGINE AVE/UL2	
CITY	CANTUA CREEK		PROJECT	
COUNTY	FRESNO		WATER REPLACEMENT	

LOCATION PLAN



SECTION VIEW

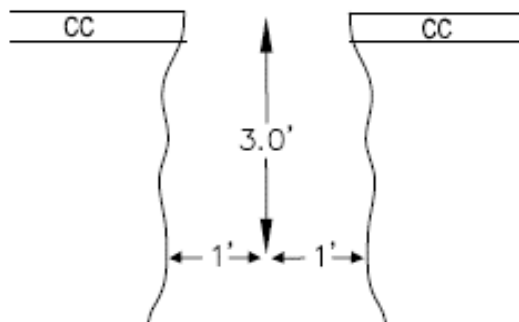

COORDINATES
 N: _____
 E: _____
 ELE: _____

NOT TO SCALE

DISCLAIMER: ADDITIONAL MATERIAL AND/OR UTILITIES MAY EXIST BELOW APPARENT BOTTOM

ENGLISH/METRIC	ENGLISH	SWING TIES FROM STRUCTURE	APPROX. DISTANCE
SURFACE TYPE	CC	A	EDGE OF GUTTER
THICKNESS	6"	B	WATER METER
SOIL CONDITIONS	CLAY	C	
UTILITY TYPE	WATER	UTILITY OWNER:	-
UTILITY SIZE		DETERMINED BY:	-
UTILITY MATERIAL		DESIGNATED:	-
MARKET SET			
			DATA ENTERED BY:
			ELIZABETH TURMAN
			REVIEWED BY:
			RICHARD HERNANDEZ

REMARKS

OPENED UP TH ON MEASUREMENT FROM CLIENT AND CLEARED DOWN TO 3' AS PER OUR CONVERSATION. CLEARED 1' EAST AND WEST. NO DRAIN LINE. REP SAID DRAIN LINE IS @ 18".

NOTE: MATERIAL INDICATED IS BASED ON VISUAL OBSERVATION OF EXPOSED UTILITY. ACTUAL MATERIAL MAY DIFFER

Before



Utility



Rod



After



TEST HOLE DATA FORM

SUE CREW	EC/DW	 5622 Research Drive, Suite A Huntington Beach, CA 92649 TEL: 714.487.5780 FAX: 714.893.1369	TEST HOLE NUMBER	14
TRUCK NO.	550603		DATE EXCAVATED	8/28/2018
CLIENT PROJECT NO.	UL-2		LOCATION	
CARDNO PROJECT NO.	CA12000300		DOMENGINE AVE/UL2	
CITY	CANTUA CREEK		PROJECT	
COUNTY	FRESNO		WATER REPLACEMENT	

LOCATION PLAN



SECTION VIEW

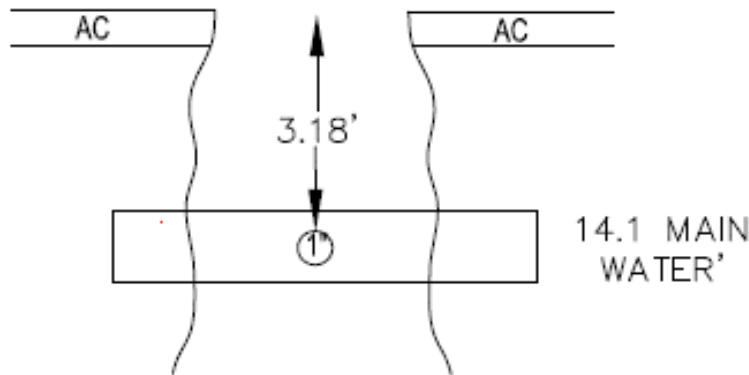

COORDINATES
 N: _____
 E: _____
 ELE: _____

NOT TO SCALE

DISCLAIMER: ADDITIONAL MATERIAL AND/OR UTILITIES MAY EXIST BELOW APPARENT BOTTOM

ENGLISH/METRIC	ENGLISH	SWING TIES FROM STRUCTURE	APPROX. DISTANCE
SURFACE TYPE	AC/AB	A	WATER VALVE 70.30'
THICKNESS	5" / 4"	B	WATER METER 15.1'
SOIL CONDITIONS	CLAY	C	EDGE OF GUTTER 24.46'
UTILITY TYPE	WATER	UTILITY OWNER:	- DATA ENTERED BY:
UTILITY SIZE	1"	DETERMINED BY:	- ELIZABETH TURMAN
UTILITY MATERIAL	PVC	DESIGNATED:	- REVIEWED BY:
MARKET SET	N & D		RICHARD HERNANDEZ

REMARKS

OPENED UP TH ON USA MARKS AND FOUND 8" MAIN WATER LINE AND W/M CONNECTION. SEE TH 14.1 FOR INFO.

NOTE: MATERIAL INDICATED IS BASED ON VISUAL OBSERVATION OF EXPOSED UTILITY. ACTUAL MATERIAL MAY DIFFER

Before



Utility



Rod

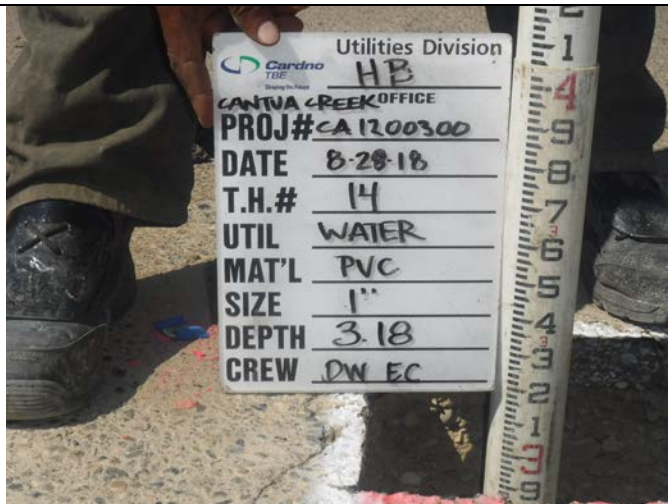

After



TEST HOLE DATA FORM

SUE CREW	EC/DW	 5622 Research Drive, Suite A Huntington Beach, CA 92649 TEL: 714.487.5780 FAX: 714.893.1369	TEST HOLE NUMBER	14.1
TRUCK NO.	550603		DATE EXCAVATED	8/28/2018
CLIENT PROJECT NO.	UL-2		LOCATION	DOMENGINE AVE/UL2
CARDNO PROJECT NO.	CA12000300		PROJECT	WATER REPLACEMENT
CITY	CANTUA CREEK			
COUNTY	FRESNO			

LOCATION PLAN



SECTION VIEW

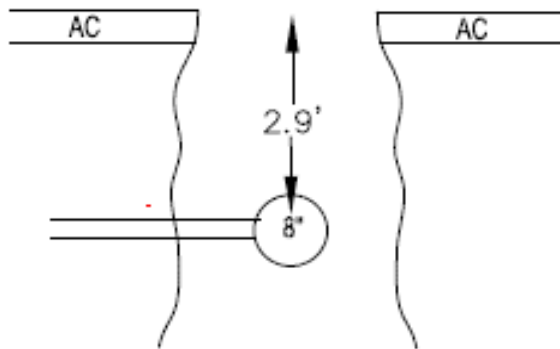

NOT TO SCALE

COORDINATES
 N: _____
 E: _____
 ELE: _____

DISCLAIMER: ADDITIONAL MATERIAL AND/OR UTILITIES MAY EXIST BELOW APPARENT BOTTOM

ENGLISH/METRIC	ENGLISH	SWING TIES FROM STRUCTURE	APPROX. DISTANCE
SURFACE TYPE	AC AB	A	WATER VALVE 71.00'
THICKNESS	5" / 4"	B	WATER METER 16.50'
SOIL CONDITIONS	CLAY	C	EDGE OF GUTTER 23.10'
UTILITY TYPE	WATER	UTILITY OWNER:	- DATA ENTERED BY:
UTILITY SIZE	8"	DETERMINED BY:	- ELIZABETH TURMAN
UTILITY MATERIAL	ACP	DESIGNATED:	- REVIEWED BY:
MARKET SET	N & D		RICHARD HERNANDEZ

REMARKS

THIS TH IS THE UTILITY WE WERE LOOKING FOR IN TH-15. USA MARKS WERE 2.6' OFF.

NOTE: MATERIAL INDICATED IS BASED ON VISUAL OBSERVATION OF EXPOSED UTILITY. ACTUAL MATERIAL MAY DIFFER

Before



Utility

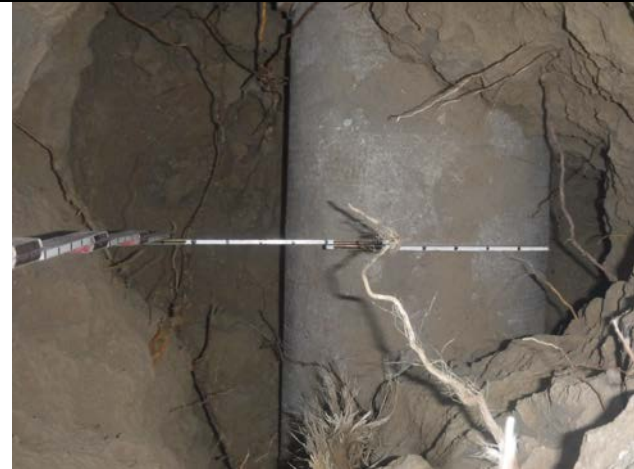

Rod

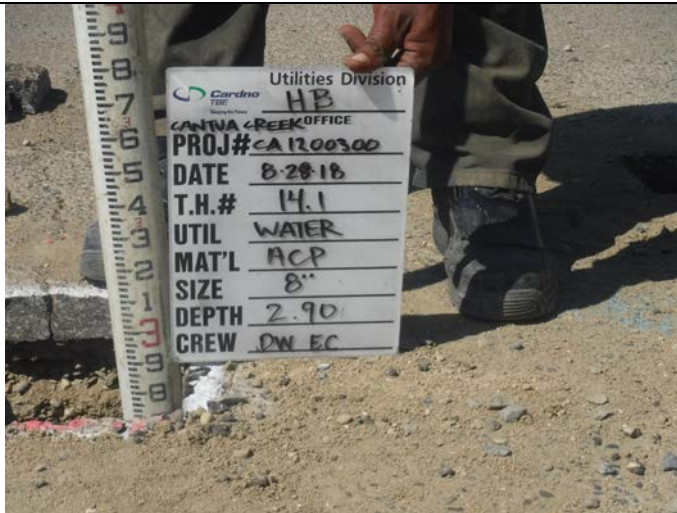

After



TEST HOLE DATA FORM

SUE CREW	EC/DW	 5622 Research Drive, Suite A Huntington Beach, CA 92649 TEL: 714.487.5780 FAX: 714.893.1369	TEST HOLE NUMBER	15
TRUCK NO.	550603		DATE EXCAVATED	8/28/2018
CLIENT PROJECT NO.	UL-2		LOCATION	DOMENGINE AVE/UL2
CARDNO PROJECT NO.	CA12000300		PROJECT	WATER REPLACEMENT
CITY	CANTUA CREEK			
COUNTY	FRESNO			

LOCATION PLAN



SECTION VIEW

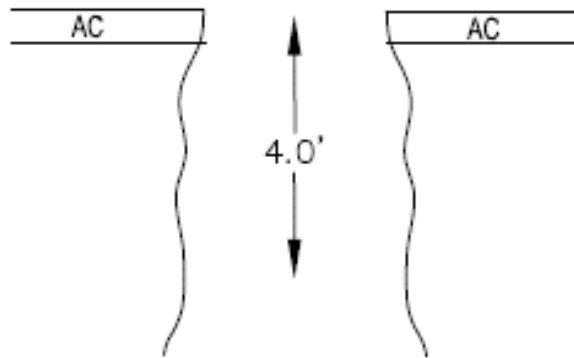

NOT TO SCALE

COORDINATES
 N: _____
 E: _____
 ELE: _____

DISCLAIMER: ADDITIONAL MATERIAL AND/OR UTILITIES MAY EXIST BELOW APPARENT BOTTOM

ENGLISH/METRIC	ENGLISH	SWING TIES FROM STRUCTURE	APPROX. DISTANCE
SURFACE TYPE	AC/AB	A	WATER VALVE 71.80'
THICKNESS	5" / 4"	B	WATER METER 19.20'
SOIL CONDITIONS	CLAY	C	EDGE OF GUTTER 20.60'
UTILITY TYPE	WATER	UTILITY OWNER:	- DATA ENTERED BY:
UTILITY SIZE		DETERMINED BY:	- ELIZABETH TURMAN
UTILITY MATERIAL		DESIGNATED:	- REVIEWED BY:
MARKET SET	N & D		RICHARD HERNANDEZ

REMARKS

OPENED UP TH ON USA. UTILITY IS AN AC LINE. CLEARED DOWN TO 6'. NO UTILITY FOUND.

NOTE: MATERIAL INDICATED IS BASED ON VISUAL OBSERVATION OF EXPOSED UTILITY. ACTUAL MATERIAL MAY DIFFER

Before



Utility



Rod

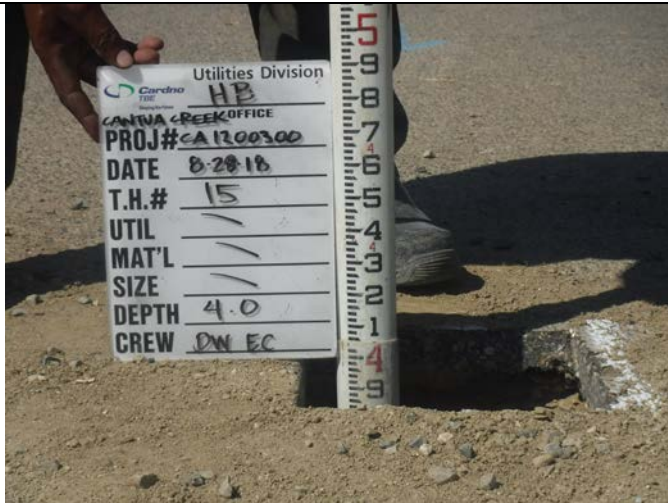

After



TEST HOLE DATA FORM

SUE CREW	EC/DW	 5622 Research Drive, Suite A Huntington Beach, CA 92649 TEL: 714.487.5780 FAX: 714.893.1369	TEST HOLE NUMBER	16
TRUCK NO.	550603		DATE EXCAVATED	8/28/2018
CLIENT PROJECT NO.	UL-2		LOCATION	DOMENGINE AVE/UL2
CARDNO PROJECT NO.	CA12000300		PROJECT	WATER REPLACEMENT
CITY	CANTUA CREEK			
COUNTY	FRESNO			

LOCATION PLAN



SECTION VIEW

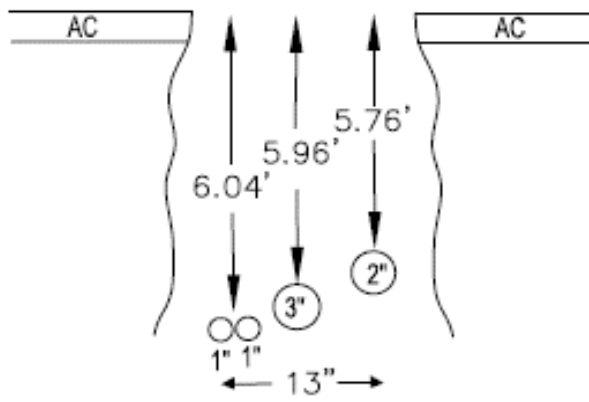

NOT TO SCALE

COORDINATES
 N: _____
 E: _____
 ELE: _____

DISCLAIMER: ADDITIONAL MATERIAL AND/OR UTILITIES MAY EXIST BELOW APPARENT BOTTOM

ENGLISH/METRIC	ENGLISH	SWING TIES FROM STRUCTURE	APPROX. DISTANCE
SURFACE TYPE	AC/AB	A	WATER VALVE 69.00'
THICKNESS	5" / 4"	B	WATER METER 28.40'
SOIL CONDITIONS	SANDY	C	EDGE OF GUTTER 11.20'
UTILITY TYPE	TEL/UNK/E	UTILITY OWNER:	- DATA ENTERED BY:
UTILITY SIZE	2.1", 1-3", 1-2", 13"	DETERMINED BY:	- ELIZABETH TURMAN
UTILITY MATERIAL	CPP/PVC	DESIGNATED:	- REVIEWED BY:
MARKET SET	N & D		RICHARD HERNANDEZ

REMARKS

OPENED UP TH ON USA AND DESIGNATION MARKS. FOUND A COMMON TRENCH FOR AN ELEC, UNK AND TEL LINE.

NOTE: MATERIAL INDICATED IS BASED ON VISUAL OBSERVATION OF EXPOSED UTILITY. ACTUAL MATERIAL MAY DIFFER

Before



Utility



Rod

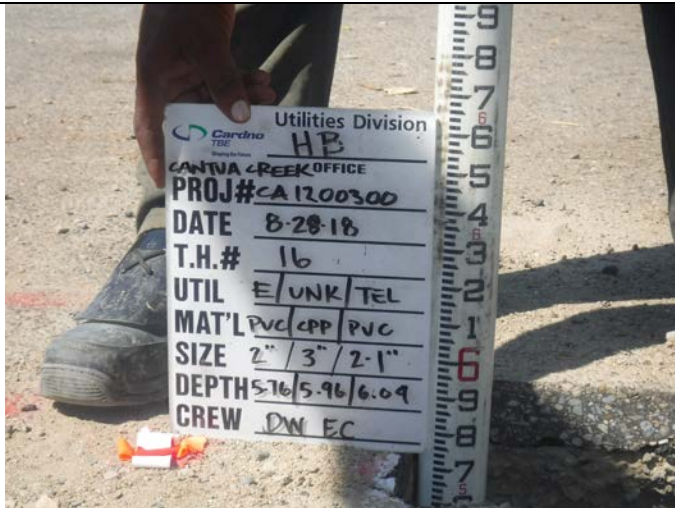

After



TEST HOLE DATA FORM

SUE CREW	EC/DW	 5622 Research Drive, Suite A Huntington Beach, CA 92649 TEL: 714.487.5780 FAX: 714.893.1369	TEST HOLE NUMBER	17
TRUCK NO.	550603		DATE EXCAVATED	8/30/2018
CLIENT PROJECT NO.	UL-3		LOCATION	
CARDNO PROJECT NO.	CA12000300		HIDALGO AVE/UL3	
CITY	CANTUA CREEK		PROJECT	
COUNTY	FRESNO		WATER REPLACEMENT	

LOCATION PLAN



SECTION VIEW

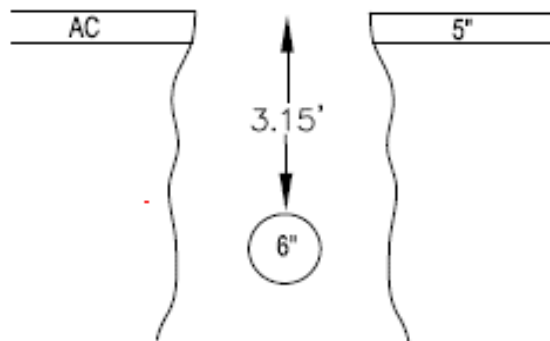

COORDINATES
 N: _____
 E: _____
 ELE: _____

NOT TO SCALE

DISCLAIMER: ADDITIONAL MATERIAL AND/OR UTILITIES MAY EXIST BELOW APPARENT BOTTOM

ENGLISH/METRIC	ENGLISH	SWING TIES FROM STRUCTURE	APPROX. DISTANCE
SURFACE TYPE	AC/AB	A	LIGHT POLE 18.80'
THICKNESS	5" / 4"	B	WATER METER 27.40'
SOIL CONDITIONS	TYPE 2	C	SSMH 24.30'
UTILITY TYPE	WATER	UTILITY OWNER:	- DATA ENTERED BY:
UTILITY SIZE	6"	DETERMINED BY:	- ELIZABETH TURMAN
UTILITY MATERIAL	AC	DESIGNATED:	- REVIEWED BY:
MARKET SET	N & D		RICHARD HERNANDEZ

REMARKS

NOTE: MATERIAL INDICATED IS BASED ON VISUAL OBSERVATION OF EXPOSED UTILITY. ACTUAL MATERIAL MAY DIFFER

Before



Utility



Rod



After



TEST HOLE DATA FORM

SUE CREW	EC/DW	 5622 Research Drive, Suite A Huntington Beach, CA 92649 TEL: 714.487.5780 FAX: 714.893.1369	TEST HOLE NUMBER	18
TRUCK NO.	550603		DATE EXCAVATED	8/30/2018
CLIENT PROJECT NO.	UL-3		LOCATION	HIDALGO AVE/UL3
CARDNO PROJECT NO.	CA12000300		PROJECT	WATER REPLACEMENT
CITY	CANTUA CREEK			
COUNTY	FRESNO			

LOCATION PLAN



SECTION VIEW

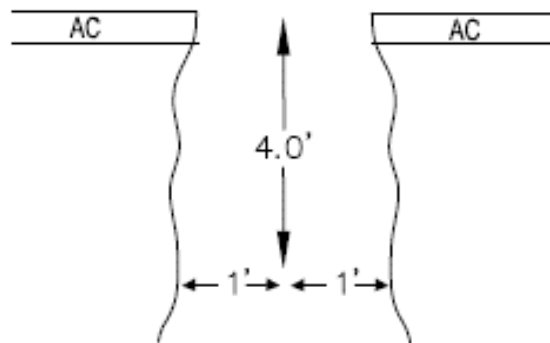

COORDINATES
 N: _____
 E: _____
 ELE: _____

NOT TO SCALE

DISCLAIMER: ADDITIONAL MATERIAL AND/OR UTILITIES MAY EXIST BELOW APPARENT BOTTOM

ENGLISH/METRIC	ENGLISH	SWING TIES FROM STRUCTURE	APPROX. DISTANCE
SURFACE TYPE	AC/AB	A	LIGHT POLE 21.30'
THICKNESS	5" / 4"	B	WATER METER 33.90'
SOIL CONDITIONS	TYPE 2	C	SSMH 20.30'
UTILITY TYPE	WATER	UTILITY OWNER:	- DATA ENTERED BY:
UTILITY SIZE		DETERMINED BY:	- ELIZABETH TURMAN
UTILITY MATERIAL		DESIGNATED:	- REVIEWED BY:
MARKET SET			RICHARD HERNANDEZ

REMARKS

OPENED UP TH ON USA MARK AND CLEARED DOWN 4'. NO UTILITY FOUND. TRIED TO DESIGNATE BUT WHEN WE CLEARED OUT WM BOX, WE OBSERVED A LATERAL CONNECTION IN BLACK PLASTIC. NOT ABLE TO LOCATE.

NOTE: MATERIAL INDICATED IS BASED ON VISUAL OBSERVATION OF EXPOSED UTILITY. ACTUAL MATERIAL MAY DIFFER

Before



Utility



Rod



After



TEST HOLE DATA FORM

SUE CREW	EC/DW	 5622 Research Drive, Suite A Huntington Beach, CA 92649 TEL: 714.487.5780 FAX: 714.893.1369	TEST HOLE NUMBER	19
TRUCK NO.	550603		DATE EXCAVATED	8/28/2018
CLIENT PROJECT NO.	UL-4		LOCATION	
CARDNO PROJECT NO.	CA12000300		S. SANTA CLARA AVE/UL4	
CITY	CANTUA CREEK		PROJECT	
COUNTY	FRESNO		WATER REPLACEMENT	

LOCATION PLAN



SECTION VIEW

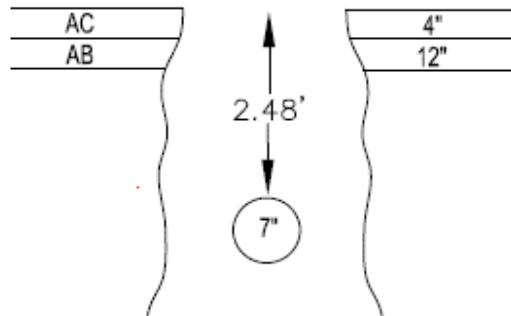

COORDINATES
 N: _____
 E: _____
 ELE: _____

NOT TO SCALE

DISCLAIMER: ADDITIONAL MATERIAL AND/OR UTILITIES MAY EXIST BELOW APPARENT BOTTOM

ENGLISH/METRIC	ENGLISH	SWING TIES FROM STRUCTURE	APPROX. DISTANCE
SURFACE TYPE	AC/AB	A	FACE OF CURB 15.80'
THICKNESS	4"/10"	B	FACE OF CURB 24.30'
SOIL CONDITIONS	SANDY	C	SDCB 32.80'
UTILITY TYPE	WATER	UTILITY OWNER:	- DATA ENTERED BY:
UTILITY SIZE	7"	DETERMINED BY:	- ELIZABETH TURMAN
UTILITY MATERIAL	ACP	DESIGNATED:	- REVIEWED BY:
MARKET SET	N & D		RICHARD HERNANDEZ

REMARKS

NOTE: MATERIAL INDICATED IS BASED ON VISUAL OBSERVATION OF EXPOSED UTILITY. ACTUAL MATERIAL MAY DIFFER

Before



Utility



Rod



After

