

PLAN

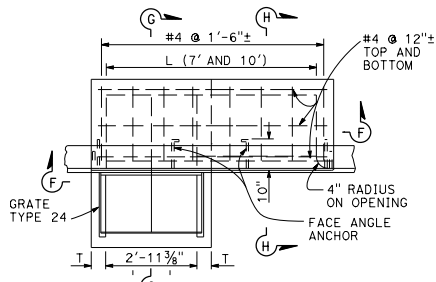

PLAN

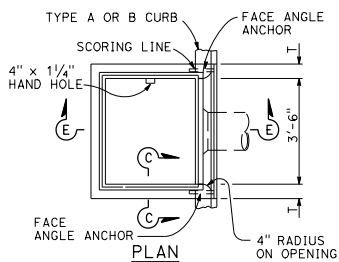

PLAN

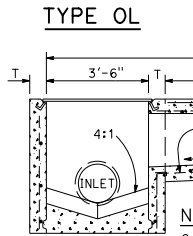

SECTION A-A

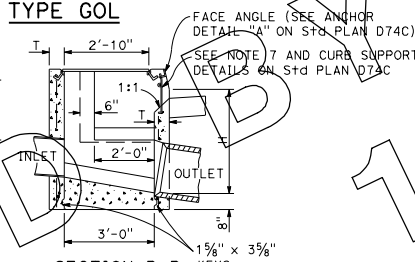

SECTION B-B

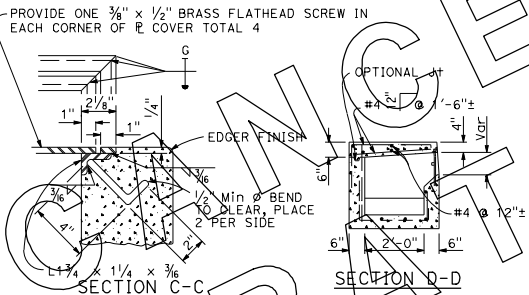

SECTION C-C

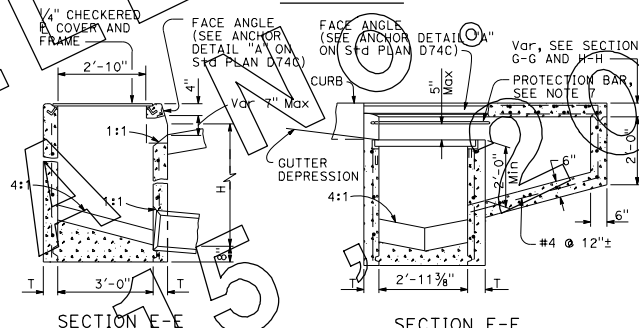

SECTION E-E

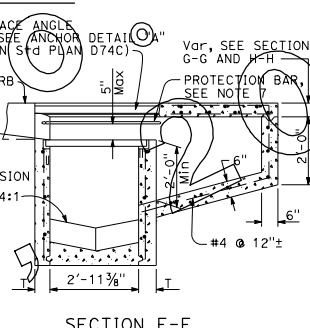

SECTION F-F

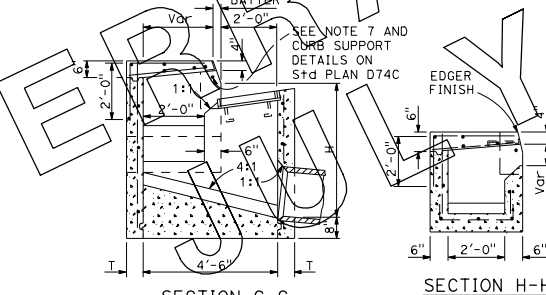

SECTION G-G

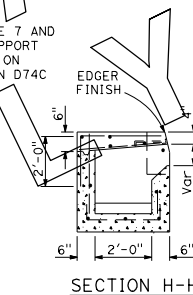

SECTION H-H

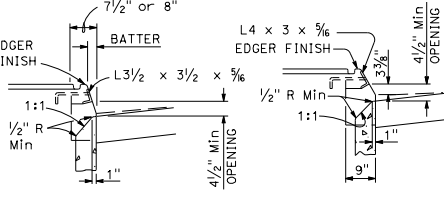

TYPE A CURBS
TYPE B CURBS
CURB OPENING DETAILS

DIST	COUNTY	ROUTE	POST MILES TOTAL PROJECT	SHEET TOTAL SHEETS

REGISTERED CIVIL ENGINEER
 No. C59976
 Exp. 6-30-16
 CIVIL
 STATE OF CALIFORNIA

October 30, 2015
 PLANS APPROVAL DATE
 THE STATE OF CALIFORNIA OR ITS OFFICERS OR AGENTS SHALL NOT BE RESPONSIBLE FOR THE ACCURACY OR COMPLETENESS OF SCANNED COPIES OF THIS PLAN SHEET.

NOTES:

- "H" is the difference in elevation between the outlet pipe flow line and the normal gutter grade line undepressed at the curb face.
- For "T" wall thickness, see Table A below.
- Height of curb opening will vary with the type of curb and the depth of the local depression.
- Wall reinforcing not required when "H" is 8'-0" or less and the unsupported width or length is 7'-0" or less. Walls exceeding these limits shall be reinforced with #4 bars @ 1'-6" ± centers placed 1/2" clear to inside of box unless otherwise shown.
- Inlet bottom reinforcing not required. See Standard Plan D74C for alternative reinforced bottom.
- Steps-None required when "H" is less than 2'-6". Where "H" is 2'-6" or more, install steps with lowest rung 1'-0" above the floor and highest rung not more than 6" below top of inlet. The distance between steps shall not exceed 1'-0" and be uniform throughout the length of the wall. Place steps in the wall without an opening. Step inserts may be substituted for the bar steps. Step inserts shall comply with State Industrial Safety requirements. See Standard Plan D74C for step details.
- When shown on the project plans, place a 3/4" plain round protection bar horizontally across the length of the opening and bend back 4" into the inlet wall on each side.
- Pipe(s) can be placed in any wall.
- Curb section shall match adjacent curb.
- Except for inlets used as junction boxes, basin floor shall have a minimum slope of 4:1 from all directions toward outlet pipe and shall have a wood trowel finish.
- See Standard Plans D77A and D77B for grate and frame details and weights of miscellaneous iron and steel.
- See Standard Plan D78A for gutter depression details.
- Complete joint penetration butt welds may be substituted for the fillet welds on all anchors.
- Standard square, hexagon, round or equivalent headed anchors may be substituted for the right angle hooks on the anchors shown on this plan.
- Cast-in-place inlets to be formed around all pipes/stubs intersecting the inlet, and concrete poured in one continuous operation. Precast inlets shall have mortared connections conforming to details for Type GCP Inlet shown on Standard Plan D75B. See Standard Specifications for mortar composition.

**TABLE A
CONCRETE QUANTITIES**

TYPE	H=3'-0" TO 8'-0" (T=6")		H=8'-1" TO 20'-0" (T=8")	
	H=3'-0" (CY)	ADDITIONAL PCC PER FOOT (CY)	H=8'-1" (CY)	ADDITIONAL PCC PER FOOT (CY)
OS	1.41	0.278	3.81	0.387
OL-7	1.92	0.278	4.29	0.387
OL-10	2.39	0.278	4.77	0.387
OL-14	3.06	0.278	5.45	0.387
OL-21	4.42 *	0.278	6.78	0.387
GOL-7	2.33	0.313	4.96	0.434
GOL-10	2.84	0.313	5.47	0.434

* Based on H=3.1'
Table based on 8" floor slab, 7" curb openings, and curb type giving highest quantity of concrete. No deductions or adjustments are to be made to these quantities because of pipe openings, different floor alternatives, different curb types or different height of curb openings.

STATE OF CALIFORNIA
DEPARTMENT OF TRANSPORTATION

DRAINAGE INLETS

NO SCALE

D72

2015 STANDARD PLAN D72

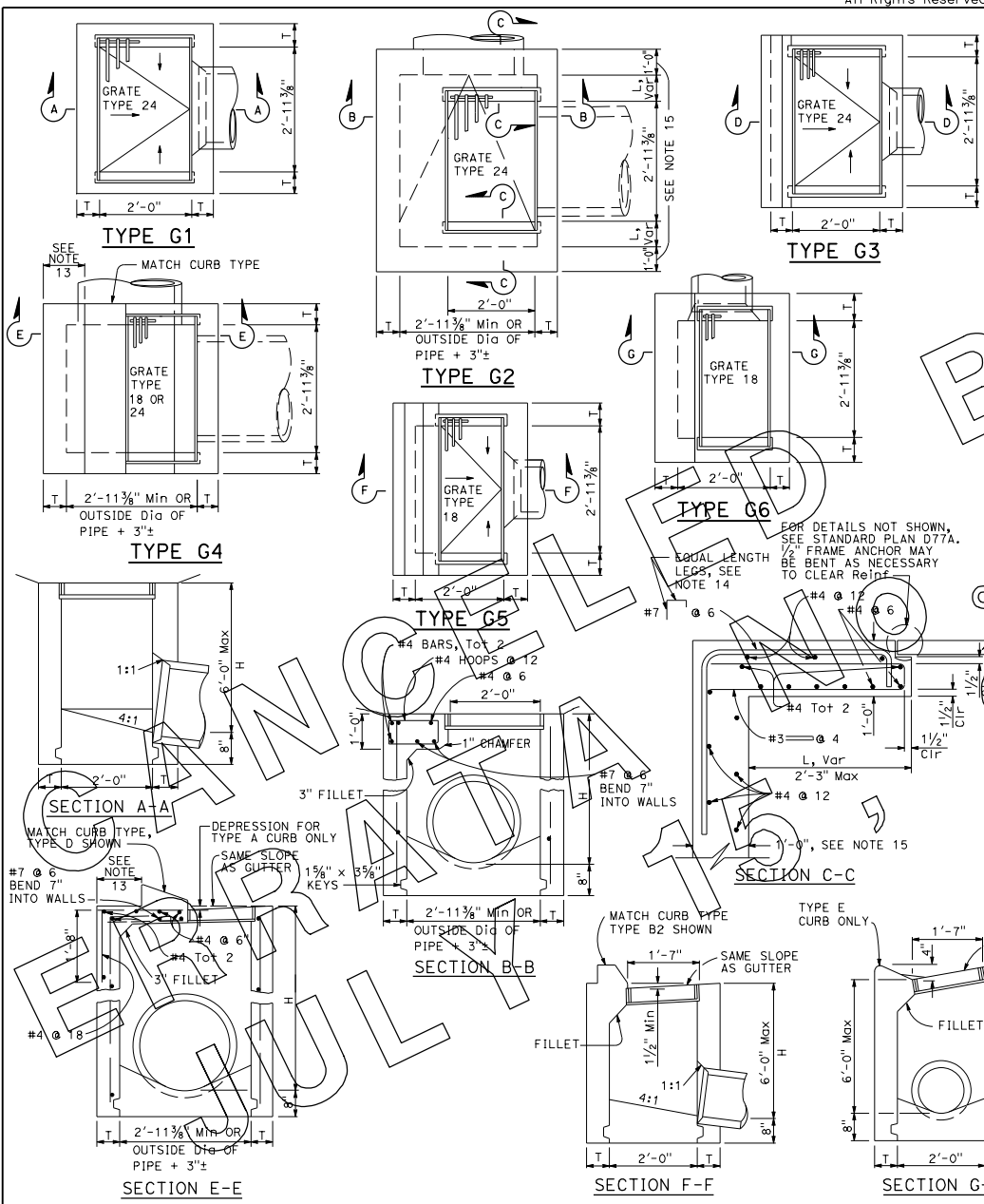

NOTES:

- "H" is the difference in elevation between the outlet pipe flow line and the normal gutter grade line undepressed.
- For "T" wall thickness, see Table A below.
- Wall reinforcing not required when "H" is 8'-0" or less and the unsupported width or length is 7'-0" or less. Walls exceeding these limits shall be reinforced with #4 bars @ 1'-6" centers placed 1/2" clear to inside of box unless otherwise shown.
- Inlet bottom reinforcing not required. See Standard Plan D74C for alternative reinforced bottom and alternative half round bottom.
- Steps are required where "H" is less than 2'-6" where "H" is 2'-6" or more, install steps with lowest rung 1'-0" above the floor and highest rung not more than 6" below top of inlet. The distance between steps shall not exceed 1'-0" and shall be uniform throughout the length of the wall. Place steps in the wall without an opening. Step inserts may be substituted for the bar steps. Step inserts shall comply with State Industrial Safety requirements. See Standard Plan D74C for step details.
- Details shown apply to both metal and concrete pipe.
- Pipe(s) can be placed in any wall.
- Curb section shall match adjacent curb.
- Basin floors shall have wood trowel finish and a minimum slope of 4:1 from all directions toward outlet pipe.
- Set inlet so that grate bars are parallel to direction of principal surface flow.
- See Standard Plans D77A and D77B for grate and frame details and weights of miscellaneous iron and steel.
- See Standard Plan D78A for gutter depression details.
- This dimension will vary with different grates, curbs types, box width and wall thickness.
- Bar may be rotated as necessary to clear opening. Where "L" is 6" or less, bar may be omitted.
- Where "L" is 6" or less, wall thickness shall be as shown in Table A.
- Cast-in-place inlets to be formed around all pipes/stubs intersecting the inlet, and concrete poured in one continuous operation. Precast inlets shall have mortared connections conforming to details for Type GCP inlet shown on Standard Plan D75B. See Standard Specifications for mortar composition.

TABLE A

TYPE	CONCRETE QUANTITIES			
	H=3'-0" TO 8'-0" (T=6")	H=8'-1" TO 20'-0" (T=8")		
	H=3'-0" (CY)	ADDITIONAL PCC PER FOOT (CY)	H=8'-1" (CY)	ADDITIONAL PCC PER FOOT (CY)
G-1	0.95	0.220	**	**
G-2*	1.31	0.255	3.50	0.357
G-3	1.03	0.220	**	**
G-4* (TYPE 24)	1.27	0.255	3.48	0.357
G-4* (TYPE 18)	1.30	0.255	3.50	0.357
G-5	1.02	0.220	**	**
G-6	1.04	0.220	**	**

Table based on 8" floor slab. No deductions are to be made to these quantities because of pipe openings, different floor alternatives or different curb types.
* Quantities for Type G-2 and G-4 inlets based on the minimum interior dimensions.
** Maximum allowable height 6'-0".

STATE OF CALIFORNIA
DEPARTMENT OF TRANSPORTATION
DRAINAGE INLETS

NO SCALE

D73

DIST	COUNTY	ROUTE	POST MILES TOTAL PROJECT	SHEET TOTAL SHEETS

C.M. Duon
REGISTERED CIVIL ENGINEER

October 30, 2015
PLANS APPROVAL DATE

THE STATE OF CALIFORNIA OR ITS OFFICERS OR AGENTS SHALL NOT BE RESPONSIBLE FOR THE ACCURACY OR COMPLETENESS OF SCANNED COPIES OF THIS PLAN SHEET.

REGISTERED PROFESSIONAL ENGINEER
Carl M. Duon
No. C59876
Exp. 6-30-16
CIVIL
STATE OF CALIFORNIA

DIST	COUNTY	ROUTE	POST MILES TOTAL PROJECT	SHEET TOTAL NO. SHEETS
REGISTERED CIVIL ENGINEER October 30, 2015 PLANS APPROVAL DATE THE STATE OF CALIFORNIA OR ITS OFFICERS OR AGENTS SHALL NOT BE RESPONSIBLE FOR THE ACCURACY OR COMPLETENESS OF SCANNED COPIES OF THIS PLAN SHEET.				

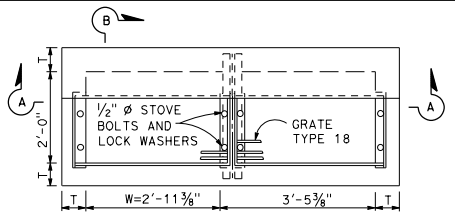

PLAN
TYPE GT1

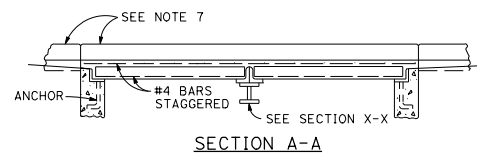

SECTION A-A

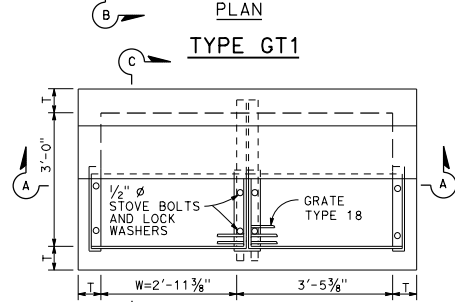

PLAN
TYPE GT2

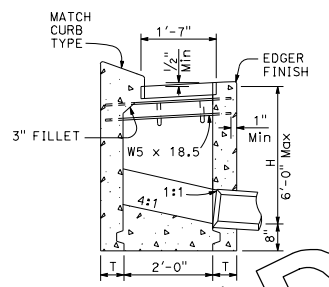

SECTION B-B

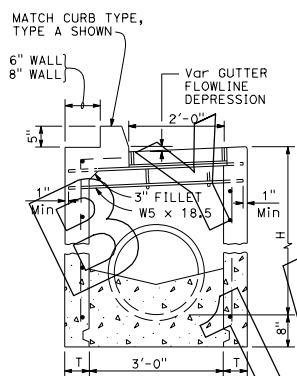

SECTION E-E

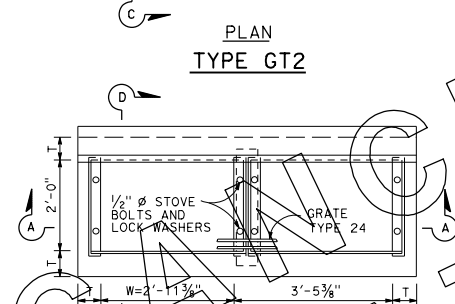

PLAN
TYPE GT3

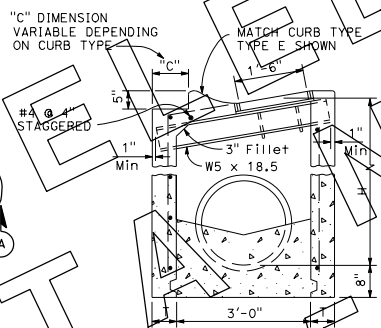

SECTION C-C

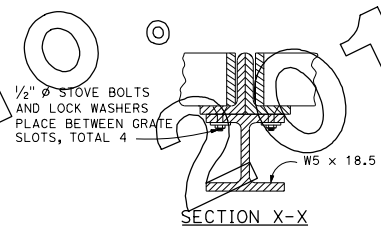

SECTION X-X

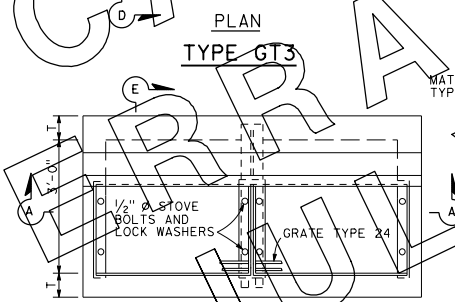

PLAN
TYPE GT4

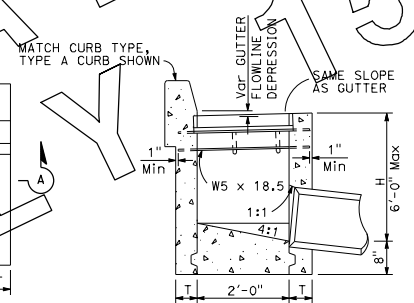

SECTION D-D

NOTES:

- "H" is the difference in elevation between the outlet pipe flow line and the normal gutter grade line undepressed.
- For "T" wall thickness, see Table A below.
- Wall reinforcing not required when "H" is 8'-0" or less and the unsupported width or length is 7'-0" or less. Walls exceeding these limits shall be reinforced with #4 bars @ 1'-6" ± centers placed 1/2" clear to inside of box unless otherwise shown.
- Inlet bottom reinforcing not required. See Standard Plan D74C for alternative reinforced bottom.
- Steps - None required where "H" is less than 2'-6". Where "H" is 2'-6" or more, install steps with lowest rung 1'-0" above the floor and highest rung not more than 6" below top of inlet. The distance between steps shall not exceed 1'-0" and shall be uniform throughout the length of the wall. Place steps in the wall without an opening. Step inserts shall comply with State Industrial Safety requirement. See Standard Plan D74C for step details.
- Pipe(s) can be placed in any wall.
- Curb section shall match adjacent curb.
- Basin floors shall have wood trowel finish and a minimum slope of 4:1 from all directions toward outlet pipe.
- W = 2'-11 3/8" for one grate. Add 3'-5 3/8" for additional grates in tandem.
- See Standard Plans D77A and D77B for grate and frame details and weights of miscellaneous iron and steel.
- See Standard Plan D78A for gutter depression details.
- Complete joint penetration butt welds may be substituted for the fillet welds on all anchors.
- Standard square, hexagon, round or equivalent headed anchors may be substituted for the right angle hooks on the anchors shown on this plan.
- Cast-in-place inlets to be formed around all pipes/stubs intersecting the inlet and concrete poured in one continuous operation. Precast inlets shall have mortared pipe connections conforming to details for Type GCP inlet on Standard Plan D75B. See Standard Specifications for mortar composition.

TABLE A
CONCRETE QUANTITIES

TYPE	H=3'-0" TO 8'-0" (T=6")		H=8'-1" TO 20'-0" (T=8")	
	H=3'-0" CY	ADDITIONAL PCC PER FOOT CY	H=8'-1" CY	ADDITIONAL PCC PER FOOT CY
GT1	1.74	0.348	*	*
GT2	2.11	0.385	5.40	0.530
GT3	1.73	0.348	*	*
GT4	2.18	0.385	5.41	0.530

Table based on 8" floor slab and curb type giving highest quantity of concrete. No deductions or adjustments are to be made to these quantities because of pipe openings, different floor alternatives or different curb type.

* Maximum allowable height = 6'-0".

STATE OF CALIFORNIA
DEPARTMENT OF TRANSPORTATION
DRAINAGE INLETS
NO SCALE

D74A

2015 STANDARD PLAN D74A

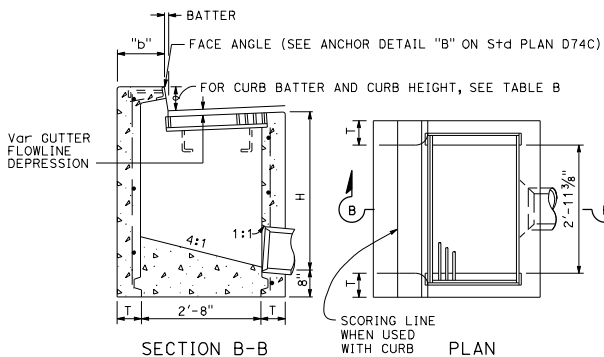

TYPE GO

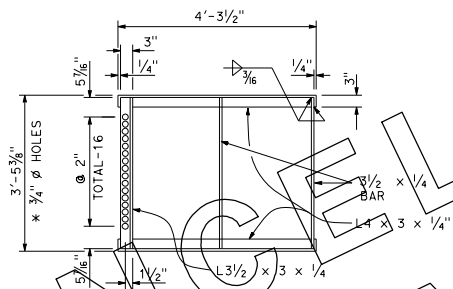

GRATE FRAME FOR TYPE GDO INLET

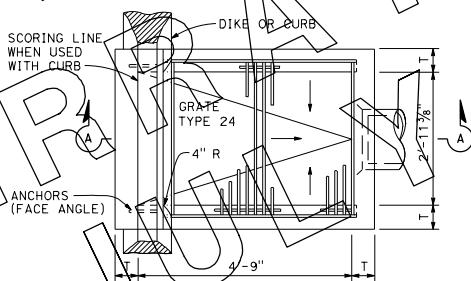

TYPE GDO

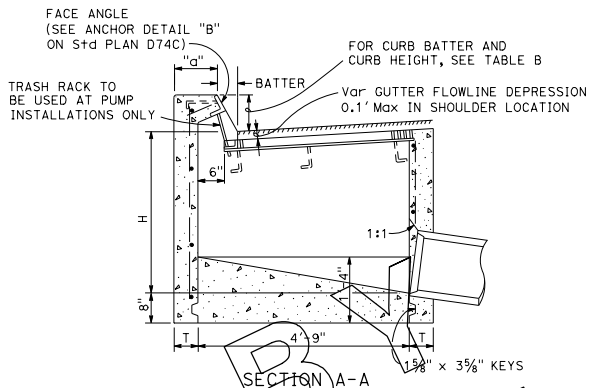

SECTION A-A

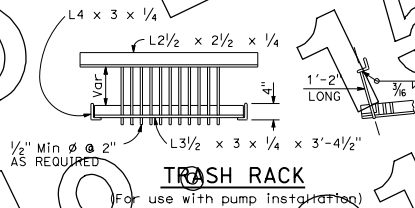

TRASH RACK

TABLE A
CONCRETE QUANTITIES

TYPE	H=3'-0" TO 8'-0" (T=6")		H=8'-1" TO 20'-0" (T=8")	
	ADDITIONAL PCC PER FOOT (CY)	H=3'-0" TO 8'-0" (T=6")	ADDITIONAL PCC PER FOOT (CY)	H=8'-1" TO 20'-0" (T=8")
GO	0.24	0.245	3.39	0.346
GDO	0.62	0.322	4.36	0.446

Table based on 8" floor slab and curb type giving highest quantity of concrete. No deductions or adjustments are to be made to these quantities because of pipe openings, different floor alternatives or different curb type.

TABLE B

CURB TYPE	NORMAL CURB HEIGHT	CURB BATTER	"a" DIMENSION	"b" DIMENSION
A1-6	6"	1 1/2"	T+7 1/2"	T+6 1/2"
A1-8	8"	2"	T+7"	T+6"
B1-6	6"	4"	T+5"	T+4"
TYPE A DIKE	6"	3"	T+6"	T+5"

DIST	COUNTY	ROUTE	POST MILES TOTAL PROJECT	SHEET TOTAL SHEETS

REGISTERED CIVIL ENGINEER
 October 30, 2015
 PLANS APPROVAL DATE
 THE STATE OF CALIFORNIA OR ITS OFFICERS OR AGENTS SHALL NOT BE RESPONSIBLE FOR THE ACCURACY OR COMPLETENESS OF SCANNED COPIES OF THIS PLAN SHEET.

NOTES:

- "H" is the difference in elevation between the outlet pipe flow line and the normal gutter grade line undepressed.
- For wall thickness, see Table A below.
- Wall reinforcing not required when "H" is 8'-0" or less and the unsupported width or length is 7'-0" or less. Walls exceeding these limits shall be reinforced with #4 @ 1'-0" centers placed 1/2" clear to inside of box unless otherwise shown.
- Inlet bottom reinforcing not required. See Standard Plan D74C for alternative reinforced bottom.
- Steps - None required where "H" is less than 2'-6" Where "H" is 2'-6" or more, install steps with lowest rung 1'-0" above the floor and highest rung not more than 6" below top of inlet. The distance between steps shall not exceed 1'-0" and shall be uniform throughout the length of the wall. Place steps in the wall without an opening. Step inserts may be substituted for the bar steps. Step Inserts shall comply with State Industrial Safety requirements. See Standard Plan D74C for step details.
- When shown on the project plans, place a 3/4" plain round protection bar horizontally across the length of the opening and bend back 4" into the inlet wall on each side.
- Pipe(s) can be placed in any wall.
- Curb section shall match adjacent curb.
- Basin floors shall have wood trowel finish and shall slope toward the outlet pipe as shown.
- See Standard Plan D77A and D77B for grate and frame details and weights of miscellaneous iron and steel.
- See Standard Plan D78A for gutter depression details.
- Complete joint penetration butt welds may be substituted for the fillet welds on all anchors.
- Standard square, hexagon, round or equivalent headed anchors may be substituted for the right angle hooks on the anchors shown on this plan.
- Cast-in-place inlets to be formed around all pipes/stubs intersecting the inlet and concrete poured in one continuous operation. Precast inlets shall have mortared pipe connections conforming to details for Type GPC inlets on Standard Plan D75B. See Standard Specifications for mortar composition.

STATE OF CALIFORNIA
DEPARTMENT OF TRANSPORTATION
DRAINAGE INLETS
NO SCALE

D74B

2015 STANDARD PLAN D74B

DIST	COUNTY	ROUTE	POST MILES TOTAL PROJECT	SHEET TOTAL NO. SHEETS



Carl M. Dunn
 REGISTERED CIVIL ENGINEER
 October 30, 2015
 PLANS APPROVAL DATE
THE STATE OF CALIFORNIA OR ITS OFFICERS OR AGENTS SHALL NOT BE RESPONSIBLE FOR THE ACCURACY OR COMPLETENESS OF SCANNED COPIES OF THIS PLAN SHEET.

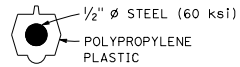

TYPICAL SECTION
(Step insert)

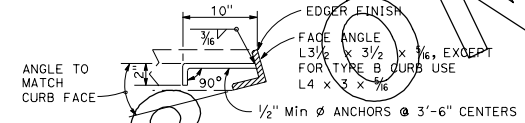
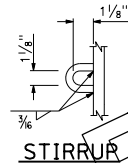

FACE ANGLE ANCHOR DETAIL "A"

LENGTH OF CURB OPENING	No. OF ANCHORS
3'-6" OR LESS	2
7'-0"	3
10'-0"	4
14'-0"	5
21'-0"	7

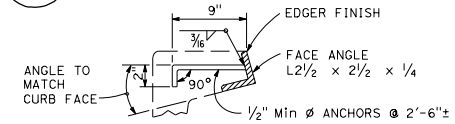

FACE ANGLE ANCHOR DETAIL "B"

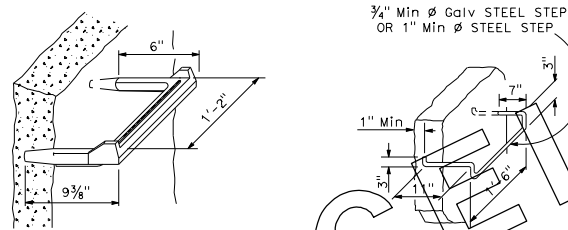

STEP INSERT

BAR STEP

STEP DETAILS

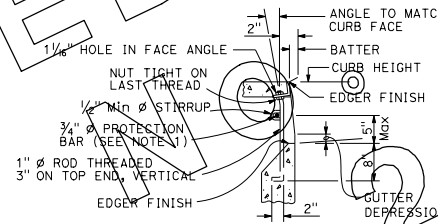

CURB SUPPORT DETAIL
See Note 2

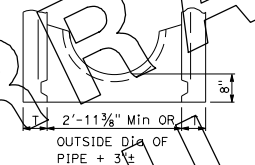

ALTERNATIVE HALF ROUND BOTTOM

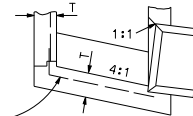

#4 @ 1'-0" CENTERS
Min Tot 3

ALTERNATIVE REINFORCED BOTTOM

NOTES:

- When shown on the project plans, place a $\frac{3}{4}$ " \varnothing plain round protection bar horizontally across length of the opening and bend back 4" into the inlet wall on each side.
- Curb supports shall be evenly spaced and minimal in number such that maximum span of unsupported curb is 7'-0".

STATE OF CALIFORNIA
DEPARTMENT OF TRANSPORTATION

DRAINAGE INLET DETAILS

NO SCALE

D74C

2015 STANDARD PLAN D74C

Dist	COUNTY	ROUTE	POST MILES TOTAL PROJECT	SHEET TOTAL No.

Paul R. Davies
REGISTERED CIVIL ENGINEER

October 30, 2015
PLANS APPROVAL DATE

Paul R. Davies
No. C52193
Exp. 12-31-16
CIVIL
STATE OF CALIFORNIA

REGISTERED PROFESSIONAL ENGINEER

THE STATE OF CALIFORNIA OR ITS OFFICERS OR AGENTS SHALL NOT BE RESPONSIBLE FOR THE ACCURACY OR COMPLETENESS OF ANY COPIES OF THIS PLAN SHEET.

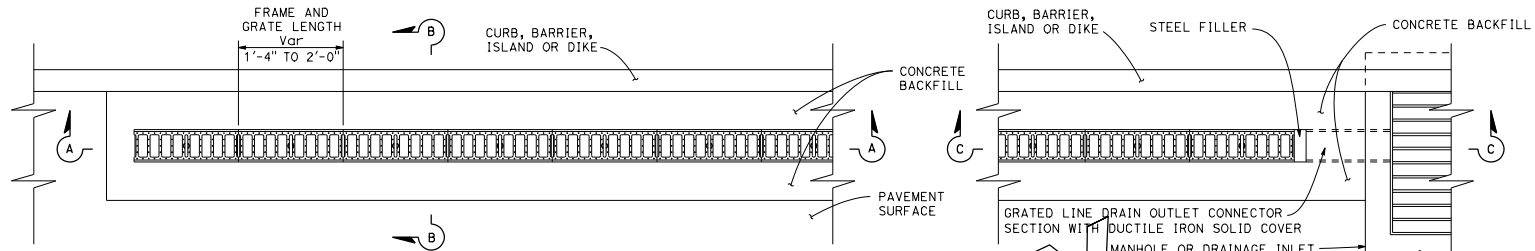

GRADED LINE DRAIN PLAN

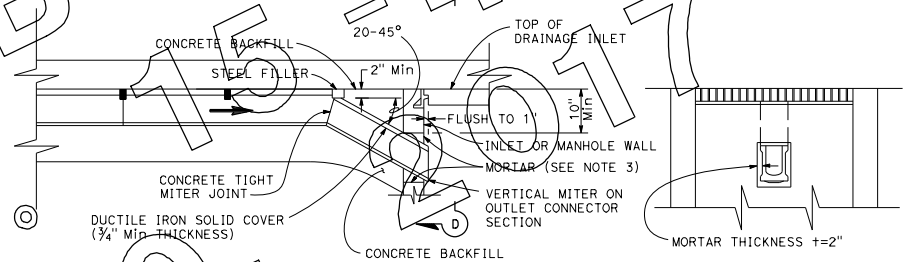
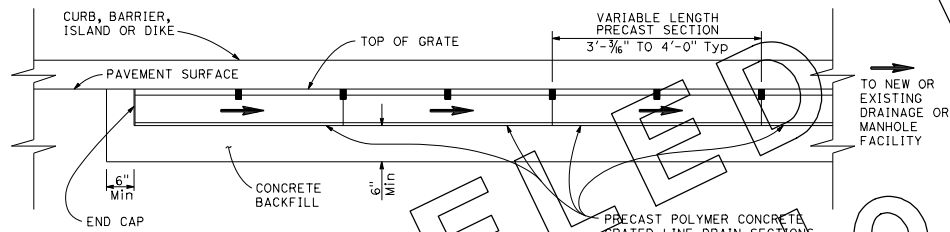

SECTION D-D

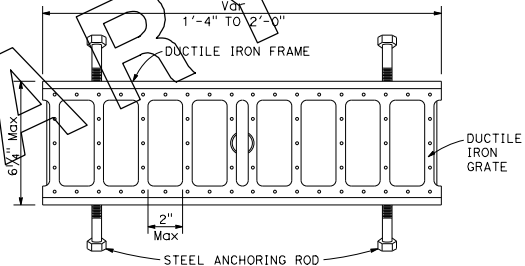
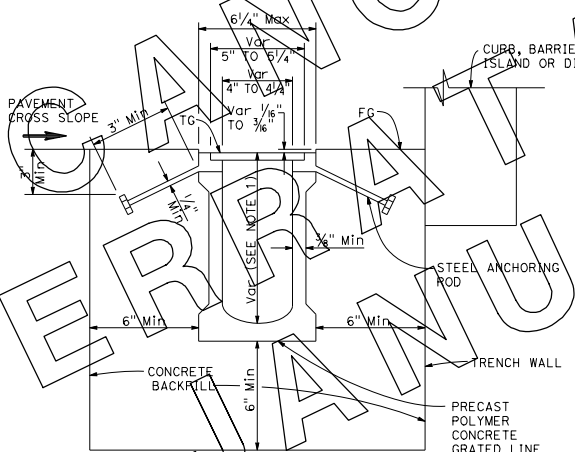

GRADED LINE DRAIN FRAME AND GRATE DETAIL

See Notes 4, 5, 6 and 7

NOTES:

1. See Project Plans for trench sections to be installed.
2. Nominal dimensions shown. Allowable tolerance $\pm 2\%$.
3. For GMP inlet connection, field joint sealed with a pliable mixture of sand, portland cement and emulsified asphalt (mixture of 1 part portland cement, 3-5 parts sand and 1/2 part SSI emulsified asphalt).
4. Within designated pedestrian paths of travel, the maximum grate opening in the direction of pedestrian traffic shall be 1/2".
5. Grate patterns may vary from detail shown. See Special Provisions for requirements.
6. Steel anchoring rods not used when frame is integral with polymer concrete graded line drain section.
7. 3/8" maximum gap between adjacent gratings.

STATE OF CALIFORNIA
DEPARTMENT OF TRANSPORTATION

**GRADED LINE DRAIN
DETAILS**

NO SCALE

D98C

DIST	COUNTY	ROUTE	POST MILES TOTAL PROJECT	SHEET NO.	TOTAL SHEETS

Theresa Gabriel
REGISTERED ELECTRICAL ENGINEER

October 30, 2015
PLANS APPROVAL DATE

Theresa Gabriel
No. E15129
Exp. 6-30-16
ELECTRICAL
STATE OF CALIFORNIA

THE STATE OF CALIFORNIA OR ITS OFFICERS OR AGENTS SHALL NOT BE RESPONSIBLE FOR THE ACCURACY OR COMPLETENESS OF SCANNED COPIES OF THIS PLAN SHEET.

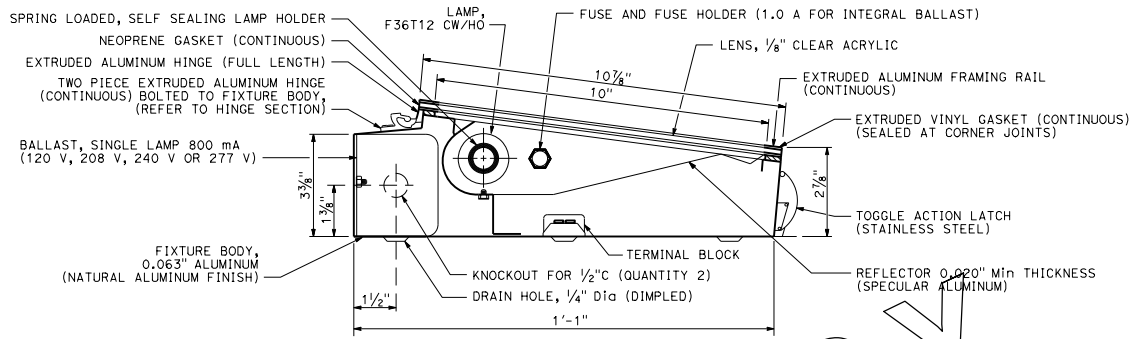

SECTION-LIGHTING FIXTURE

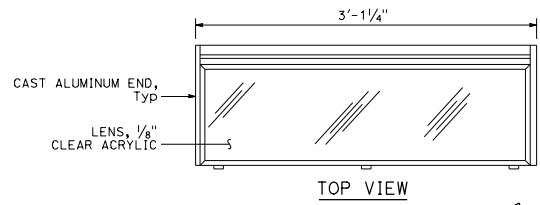

TOP VIEW

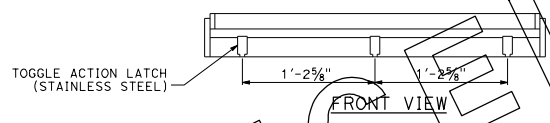

FRONT VIEW

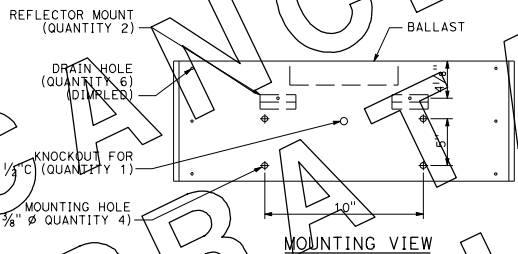

MOUNTING VIEW

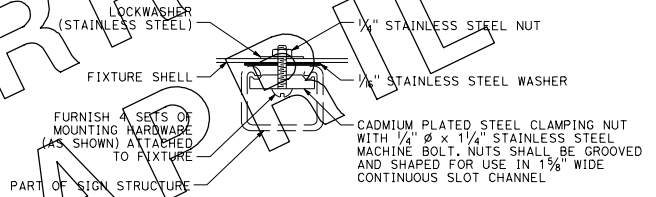

**FIXTURE MOUNTING
ON CONTINUOUS SLOT CHANNEL
DETAIL M**

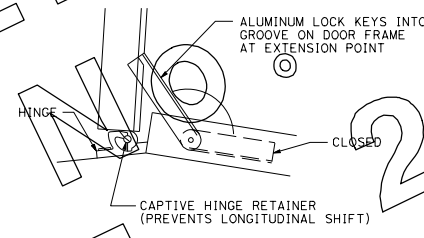

HINGE SECTION

SIGN LOAD (WATTS) AND FUSING	
1 LAMP AND BALLAST - 75 W	1 A
2 LAMPS AND BALLAST - 150 W	2.5 A
3 LAMPS AND BALLAST - 225 W	3 A

NOTES:

1. Conduit shall be secured to nearest member using one-hole galvanized malleable iron or steel straps at 5'-0" maximum centers and brass machine screws tapped into the member.
2. Ballasts and terminal boards shall be marked with legible symbols. Conductors shall be tagged and their identification marked on the corresponding terminal on the terminal board as shown on the typical fixture wiring diagram. An alternative cover design shall be submitted for approval.
3. Ballast shall be one, two or three lamp types as required, rated at 800 mA.
4. Each ballast shall be fused with 1/4" x 1/4" slow-blow glass tube fuse.
5. Fuseholder shall be a panel mounted type.
6. The fixture shall have an integral ballast.

STATE OF CALIFORNIA
DEPARTMENT OF TRANSPORTATION

**ELECTRICAL SYSTEMS
(36" FLUORESCENT SIGN
ILLUMINATION EQUIPMENT)**

NO SCALE

ES-15B

490

2015 STANDARD PLAN ES-15B

DIST	COUNTY	ROUTE	POST MILES TOTAL PROJECT	SHEET TOTAL SHEETS

REGISTERED CIVIL ENGINEER
Tillot Satter
No. C42892
Exp. 3-31-18
CIVIL
STATE OF CALIFORNIA

July 15, 2016
PLANS APPROVAL DATE

TO ACCOMPANY PLANS DATED
PLANS APPROVAL DATE

THE STATE OF CALIFORNIA OR ITS OFFICERS OR AGENTS SHALL NOT BE RESPONSIBLE FOR THE ACCURACY OR COMPLETENESS OF SKIPPED COPIES OF THIS PLAN SHEET.

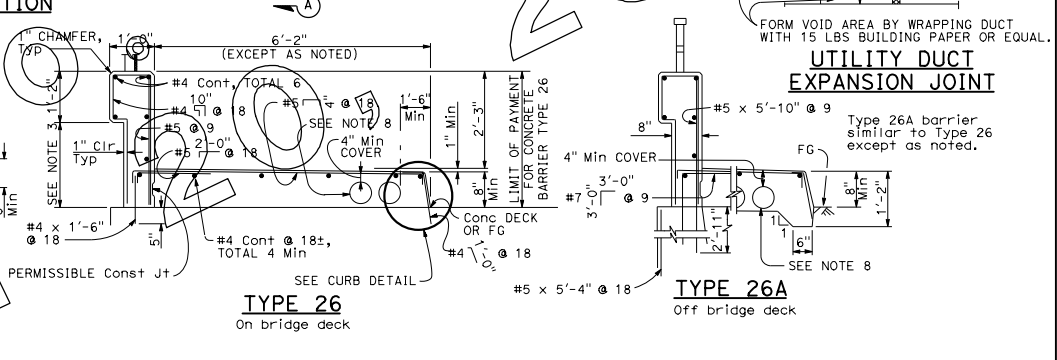
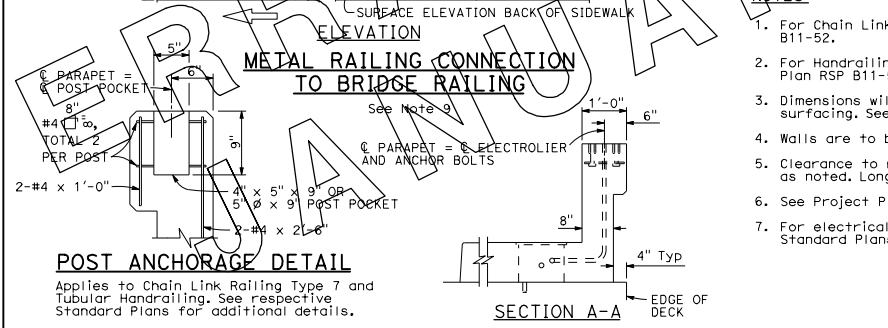
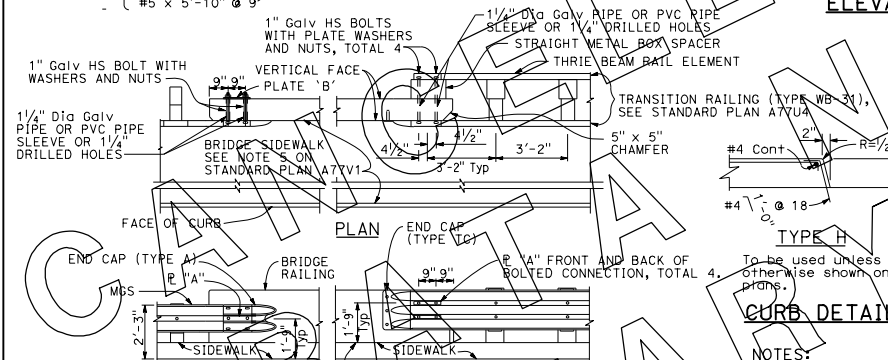
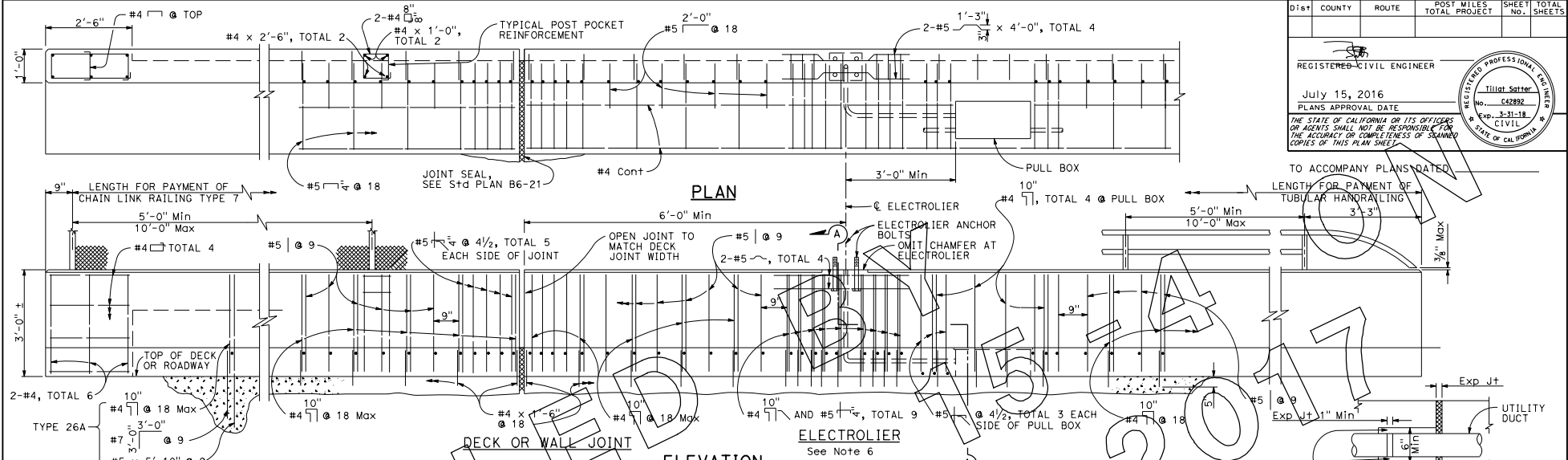

- NOTES:**
- For Chain Link Railing notes and details not shown, see Standard Plan B11-52.
 - For Handrailing notes and details not shown, see Revised Standard Plan RSP B11-51.
 - Dimensions will vary with cross slope and with certain thicknesses of surfacing. See Project Plans.
 - Walls are to be backfilled before railing is placed.
 - Clearance to reinforcing steel in curb and railing to be 1" except as noted. Longitudinal reinforcement to stop at all expansion joints.
 - See Project Plans for electrolier locations and pull box type.
 - For electrical details, see Standard Plans ES-9A, ES-9B, Revised Standard Plans RSP ES-9C, RSP ES-9D and RSP ES-9E.
 - A maximum of five - 4" and a minimum of two - 4" round openings for future utilities. Openings are to be sealed at ends and extended 8" minimum past end of sidewalk if not used. Duct forms are to be tied down. Minimum of 6" from face of rail to utility opening. See Standard Plan B14-3 for minimum spacing between conduit, and for details at joints.
 - For typical metal railing connection details not shown, see Standard Plans A77V1 and A77V2.
 - This barrier is to be used only for speeds of 45 MPH or less. For speeds greater than 45 MPH, pedestrians should be protected by a separation traffic barrier.
- STATE OF CALIFORNIA
DEPARTMENT OF TRANSPORTATION
- CONCRETE BARRIER TYPE 26**
NO SCALE
- RSP B11-54 DATED JULY 15, 2016. SUPERSEDES STANDARD PLAN B11-54 DATED OCTOBER 30, 2015 - PAGE 314 OF THE STANDARD PLANS BOOK DATED 2015.

REVISED STANDARD PLAN RSP B11-54

2015 REVISED STANDARD PLAN RSP B11-54

Dist	COUNTY	ROUTE	POST MILES TOTAL PROJECT	SHEET NO.	TOTAL SHEETS
July 21, 2017 PLANS APPROVAL DATE					
<small>THE STATE OF CALIFORNIA OR ITS OFFICERS OR AGENTS SHALL NOT BE RESPONSIBLE FOR THE ACCURACY OR COMPLETENESS OF SCANNED COPIES OF THIS PLAN SHEET.</small>					

TO ACCOMPANY PLANS DATED _____

WATER POLLUTION CONTROL

- xx--xx-- THVF --xx--xx--xx-- Temp HIGH-VISIBILITY FENCE
- xx--xx-- TSF --xx--xx--xx-- Temp SILT FENCE
- xx--xx-- TRSF --xx--xx--xx-- Temp Reinf SILT FENCE
- ////////// TFR ////////// Temp FIBER ROLL
- TGBB ○○○○○○ Temp GRAVEL BAG BERM
- TSBB ○○○○○○ Temp STRAW BALE BARRIER
- ▷||||||||| Temp SLOPE DRAIN FLEX PIPE
- ~~~~~ Temp EARTH BERM
- ←- - - - - Temp DITCH/SWALE
- Temp CONCRETE WASHOUT
- Temp DRAINAGE INLET PROTECTION
- Temp DRAINAGE OUTLET PROTECTION
- Temp CHECK DAM
- Temp CONSTRUCTION ENTRANCE
- Temp STOCKPILE

BOUNDARY LINE

- STATE OR COUNTRY
- COUNTY OR RESERVATION BOUNDARY
- CITY OR MILITARY BOUNDARY
- FOREST
- SUBDIVISION, SECTION, GRANT
- RANCHO

ENVIRONMENTALLY SENSITIVE AREA (ESA)

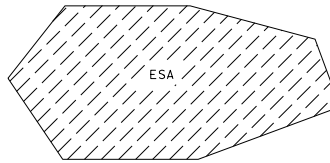

DRAINAGE

- DIRECTION FLOW OF WATER
- DRAINAGE SYSTEM SYMBOL
- DRAINAGE UNIT SYMBOL
- DRAINAGE INLET
- DITCH FLOW LINE

DRAFTING

- TILDE - DESIGNATES AN AREA
- NORTH ARROW
- ADDENDUM SHEET SYMBOL
(ADDENDUM NUMBER IS INCLUDED INSIDE THE SYMBOL.)
- MATCH LINE
- BREAK LINE

STATE OF CALIFORNIA
DEPARTMENT OF TRANSPORTATION
LEGEND
LINES AND SYMBOLS
(SHEET 2 OF 5)

NO SCALE

RSP A10B DATED JULY 21, 2017 SUPERSEDES RSP A10B DATED JANUARY 20, 2017 AND STANDARD PLAN A10B DATED OCTOBER 30, 2015 - PAGE 5 OF THE STANDARD PLANS BOOK DATED 2015.

REVISED STANDARD PLAN RSP A10B

2015 REVISED STANDARD PLAN RSP A10B

CENTERLINES
(2 LANE HIGHWAYS)

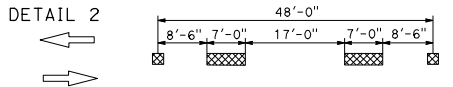
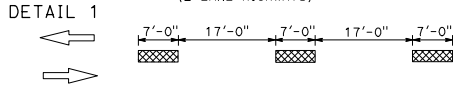

~~DETAIL 3~~ DETAIL 3 DELETED

~~DETAIL 4~~ DETAIL 4 DELETED

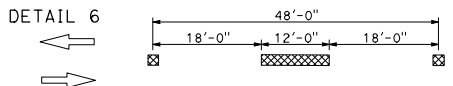
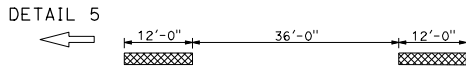

~~DETAIL 7~~ DETAIL 7 DELETED

LANELINES
(MULTILANE HIGHWAYS)

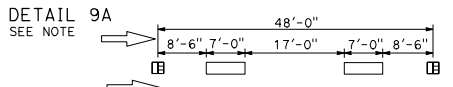
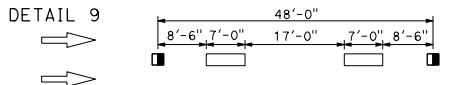
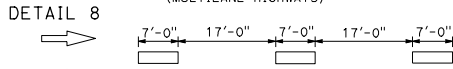

~~DETAIL 10~~ DETAIL 10 DELETED

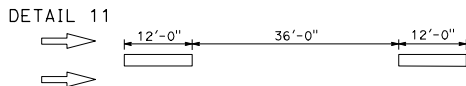

LANELINES (Cont)
(MULTILANE HIGHWAYS)

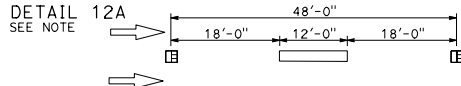
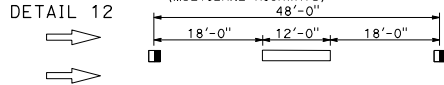

~~DETAIL 13~~ DETAIL 13 DELETED

~~DETAIL 14~~ DETAIL 14 DELETED

~~DETAIL 14A~~ DETAIL 14A DELETED

NO PASSING ZONES-ONE DIRECTION

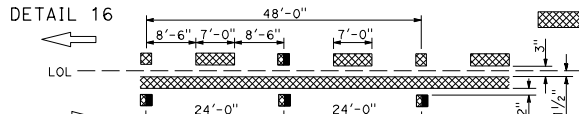
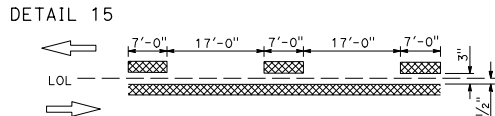

~~DETAIL 17~~ DETAIL 17 DELETED

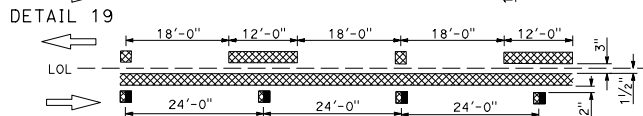
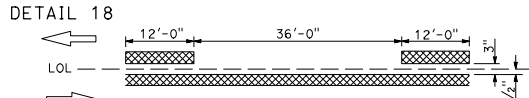

~~DETAIL 20~~ DETAIL 20 DELETED

NO PASSING ZONES-TWO DIRECTION

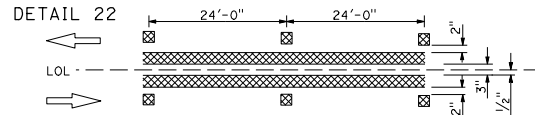
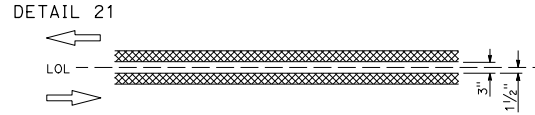

~~DETAIL 23~~ DETAIL 23 DELETED

LEGEND

MARKERS

- TYPE C RED-CLEAR RETROREFLECTIVE
- TYPE D TWO-WAY YELLOW RETROREFLECTIVE
- TYPE G ONE-WAY CLEAR RETROREFLECTIVE
- TYPE H ONE-WAY YELLOW RETROREFLECTIVE

LINES

- 6" WHITE
- 6" YELLOW

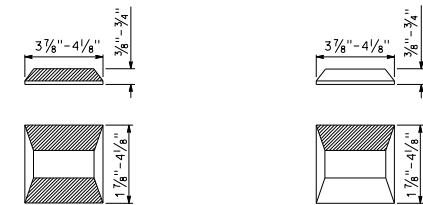

TYPE C AND TYPE D TYPE G AND TYPE H

RETROREFLECTIVE FACE

STATE OF CALIFORNIA
DEPARTMENT OF TRANSPORTATION

**PAVEMENT MARKERS
AND TRAFFIC LINES
TYPICAL DETAILS**

NO SCALE

NOTE:
FOR FREEWAY APPLICATION ONLY

RSP A20A DATED APRIL 20, 2018 SUPERSEDES RSP A20A DATED JULY 21, 2017 AND STANDARD PLAN A20A DATED OCTOBER 30, 2015 - PAGE 12 OF THE STANDARD PLANS BOOK DATED 2015.

REVISED STANDARD PLAN RSP A20A

DIST	COUNTY	ROUTE	POST MILES TOTAL PROJECT	SHEET TOTAL SHEETS

Atifa Ferouz
REGISTERED CIVIL ENGINEER

April 20, 2018
PLANS APPROVAL DATE

THE STATE OF CALIFORNIA OR ITS OFFICERS OR AGENTS SHALL NOT BE RESPONSIBLE FOR THE ACCURACY OR COMPLETENESS OF SCANNED COPIES OF THIS PLAN SHEET.

TO ACCOMPANY PLANS DATED _____

2015 REVISED STANDARD PLAN RSP A20A

LEFT EDGELINES

(DIVIDED HIGHWAYS)

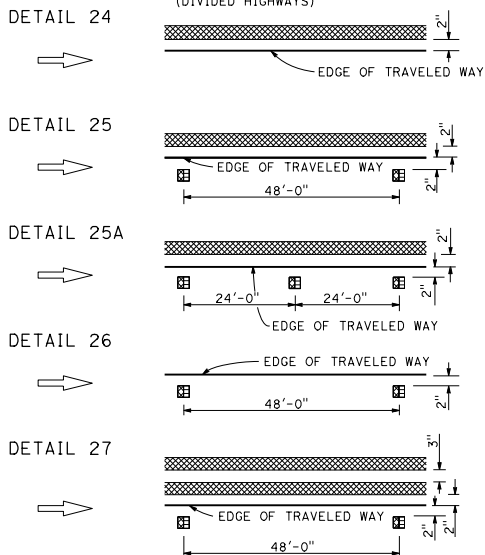

RIGHT EDGELINES

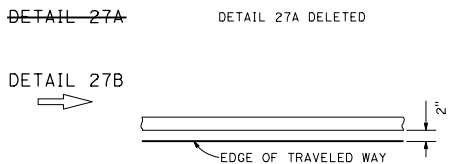

RIGHT EDGELINE EXTENSION THROUGH INTERSECTIONS

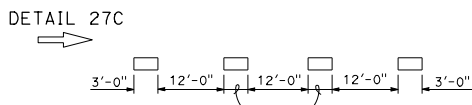

MEDIAN ISLANDS

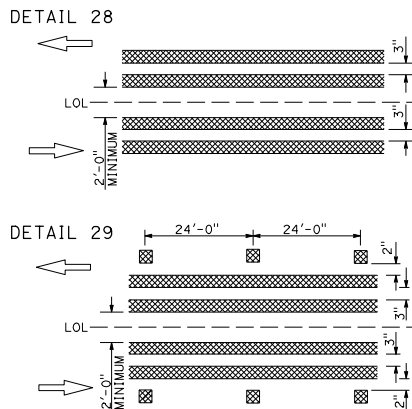

~~DETAIL 30~~ ~~DETAIL 30 DELETED~~

TWO-WAY LEFT TURN LANES

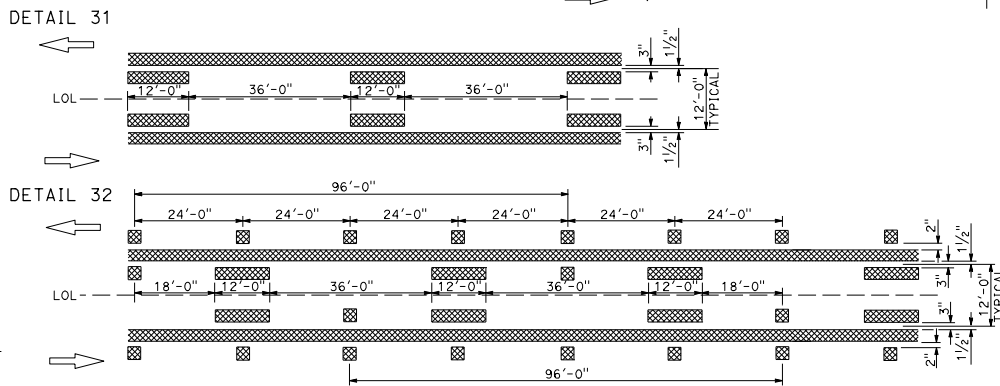

~~DETAIL 33~~ ~~DETAIL 33 DELETED~~

LEGEND

- MARKERS**
- TYPE D TWO-WAY YELLOW RETROREFLECTIVE
 - TYPE H ONE-WAY YELLOW RETROREFLECTIVE
 - TYPE RY RED-YELLOW RETROREFLECTIVE
- LINES**
- 6" WHITE
 - 6" YELLOW

INTERSECTION TREATMENTS

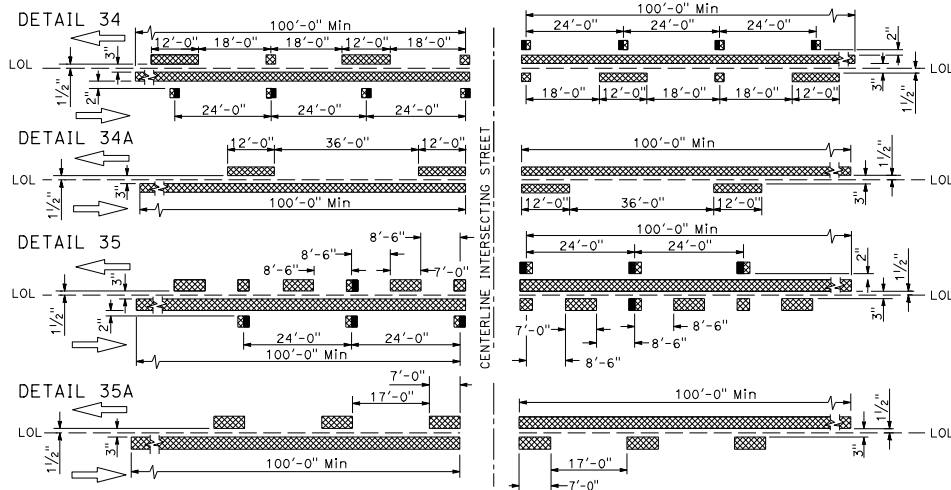

MARKER DETAILS

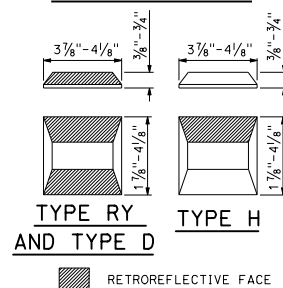

STATE OF CALIFORNIA
DEPARTMENT OF TRANSPORTATION

PAVEMENT MARKERS AND TRAFFIC LINES TYPICAL DETAILS

NO SCALE

RSP A20B DATED APRIL 20, 2018 SUPERSEDES RSP A20B DATED JULY 21, 2017 AND STANDARD PLAN A20B DATED OCTOBER 30, 2015 - PAGE 13 OF THE STANDARD PLANS BOOK DATED 2015.

REVISED STANDARD PLAN RSP A20B

DIST	COUNTY	ROUTE	POST MILES TOTAL PROJECT	SHEET NO.	TOTAL SHEETS

Atifa Ferouz
REGISTERED CIVIL ENGINEER

April 20, 2018
PLANS APPROVAL DATE

Atifa Ferouz
No. C80402
Exp. 3-31-19
CIVIL ENGINEER
STATE OF CALIFORNIA

THE STATE OF CALIFORNIA OR ITS OFFICERS OR AGENTS SHALL NOT BE RESPONSIBLE FOR THE ACCURACY OR COMPLETENESS OF SCANNED COPIES OF THIS PLAN SHEET.

2015 REVISED STANDARD PLAN RSP A20B

EXIT RAMP NEUTRAL AREA (GORE) TREATMENT

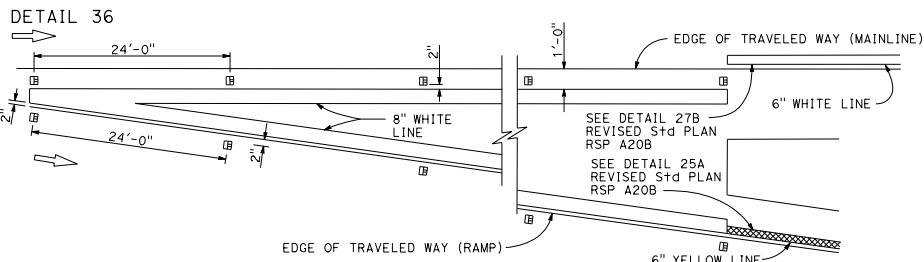

ENTRANCE RAMP NEUTRAL AREA (MERGE) TREATMENT

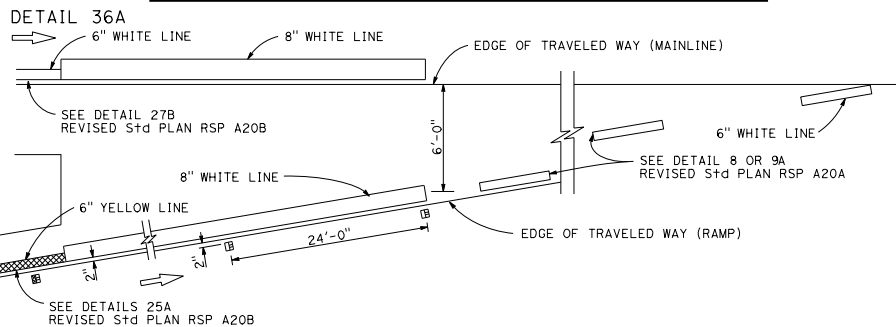

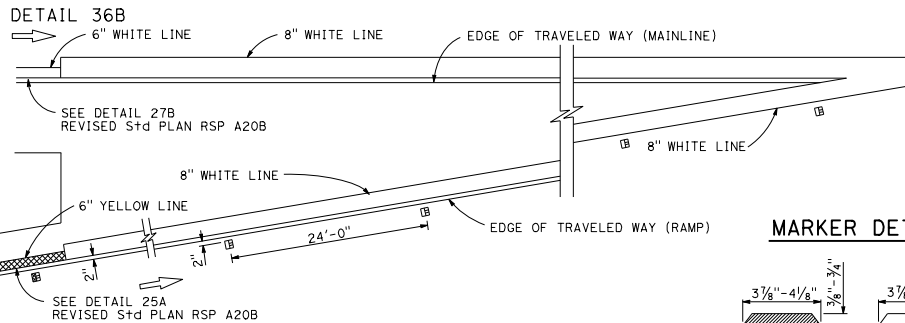

ENTRANCE RAMP NEUTRAL AREA (ACCELERATION LANE) TREATMENT



LEGEND:

MARKERS

-  TYPE C RED-CLEAR RETROREFLECTIVE
-  TYPE G ONE-WAY CLEAR RETROREFLECTIVE
-  TYPE RY RED-YELLOW RETROREFLECTIVE

MARKER DETAILS

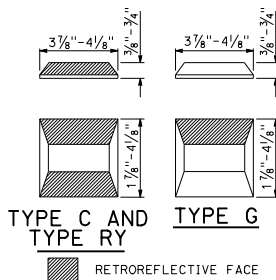

DIST	COUNTY	ROUTE	POST MILES TOTAL PROJECT	SHEET TOTAL SHEETS

Atifa Ferouz
REGISTERED CIVIL ENGINEER

April 20, 2018
PLANS APPROVAL DATE

Atifa Ferouz
No. C80402
Exp. 3-31-19
CIVIL
REGISTERED PROFESSIONAL ENGINEER
STATE OF CALIFORNIA

THE STATE OF CALIFORNIA OR ITS OFFICERS OR AGENTS SHALL NOT BE RESPONSIBLE FOR THE ACCURACY OR COMPLETENESS OF SCANNED COPIES OF THIS PLAN SHEET.

TO ACCOMPANY PLANS DATED _____

LANE DROP AT EXIT RAMP

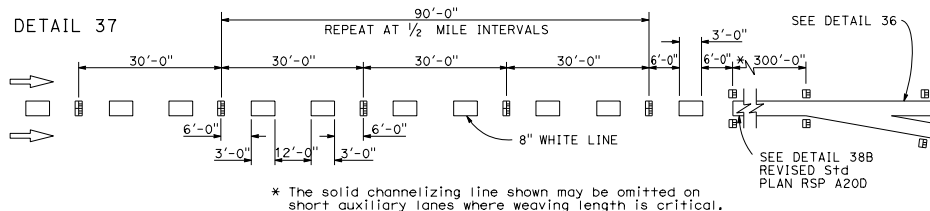

~~DETAIL 37A~~ DETAIL 37A DELETED

LANE DROP AT INTERSECTIONS

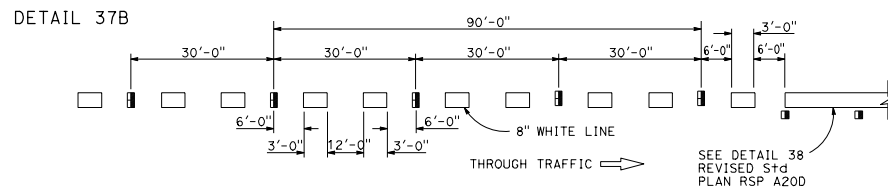

~~DETAIL 37C~~ DETAIL 37C DELETED

STATE OF CALIFORNIA
DEPARTMENT OF TRANSPORTATION

**PAVEMENT MARKERS
AND TRAFFIC LINES
TYPICAL DETAILS**

NO SCALE

RSP A20C DATED APRIL 20, 2018 SUPERSEDES RSP A20C DATED JULY 21, 2017 AND STANDARD PLAN A20C DATED OCTOBER 30, 2015 - PAGE 14 OF THE STANDARD PLANS BOOK DATED 2015.

REVISED STANDARD PLAN RSP A20C

2015 REVISED STANDARD PLAN RSP A20C

CHANNELIZING LINE

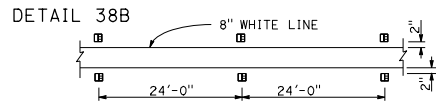
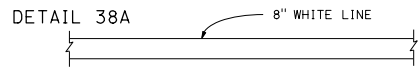
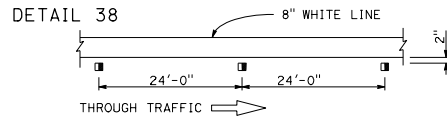

DETAIL 38C DELETED

BIKE LANE LINE

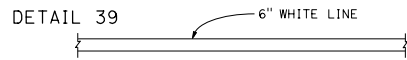

INTERSECTION LINE BIKE LANE

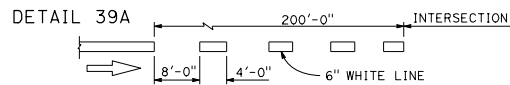

LANE LINE EXTENSIONS THROUGH INTERSECTIONS

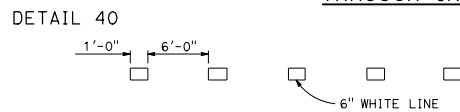

DETAIL 40A DELETED

CENTER LINE EXTENSIONS THROUGH INTERSECTIONS



DETAIL 41A DELETED

LEGEND

MARKERS

- TYPE C RED-CLEAR RETROREFLECTIVE
- TYPE G ONE-WAY CLEAR RETROREFLECTIVE
- 6" YELLOW LINE

MARKER DETAILS

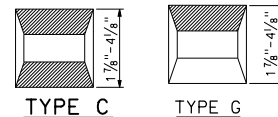
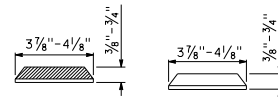

TYPE C **TYPE G**
RETROREFLECTIVE FACE

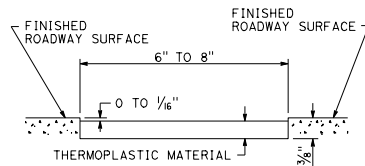

DETAIL FOR RECESSED THERMOPLASTIC TRAFFIC STRIPE

See Notes A and B.

RECESSED THERMOPLASTIC NOTES

- A. See typical traffic line details for pavement marking patterns.
- B. The top of the thermoplastic installed in recessed pavement shall be 0 to 1/16" below the pavement surface.

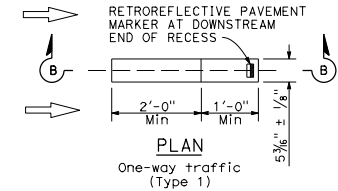
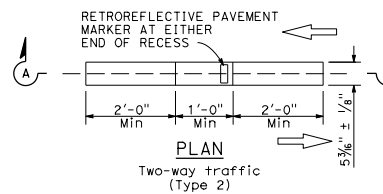
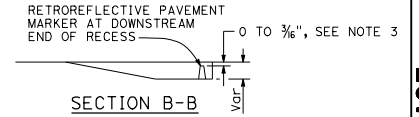
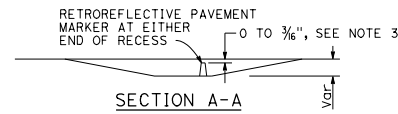

RECESS DETAIL FOR RETROREFLECTIVE PAVEMENT MARKER

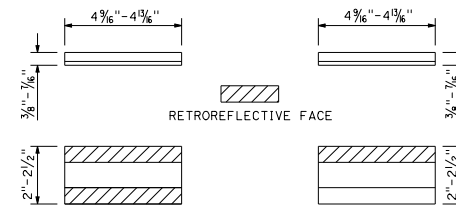

RECESSED MARKER NOTES:

1. See typical traffic line details for marker patterns to be used with recessed pavement markers. Detail 14A requires a Type 2 recess.
2. The retroreflective pavement markers shown for recessed installations are not to be used for non-recessed installations.
3. The top of pavement markers installed in recesses shall be 0 to 3/16" below the pavement surface.

TYPE C AND TYPE D **TYPE G AND TYPE H**

See Notes 1 and 2.

RETROREFLECTIVE PAVEMENT MARKER FOR RECESSED INSTALLATION

STATE OF CALIFORNIA
DEPARTMENT OF TRANSPORTATION

PAVEMENT MARKERS AND TRAFFIC LINES TYPICAL DETAILS

NO SCALE

RSP A200 DATED APRIL 20, 2018 SUPERSEDES RSP A200 DATED JULY 21, 2017 AND STANDARD PLAN A200 DATED OCTOBER 30, 2015 - PAGE 15 OF THE STANDARD PLANS BOOK DATED 2015.

REVISED STANDARD PLAN RSP A20D

2015 REVISED STANDARD PLAN RSP A20D

DIST	COUNTY	ROUTE	POST MILES TOTAL PROJECT	SHEET TOTAL SHEETS

Atifa Ferouz
REGISTERED CIVIL ENGINEER



April 20, 2018
PLANS APPROVAL DATE

Atifa Ferouz
No. C80402
Exp. 3-31-19
CIVIL
STATE OF CALIFORNIA

THE STATE OF CALIFORNIA OR ITS OFFICERS OR AGENTS SHALL NOT BE RESPONSIBLE FOR THE ACCURACY OR COMPLETENESS OF SCANNED COPIES OF THIS PLAN SHEET.

NOTES:

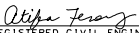
1. See Revised Standard Plans RSP A20A, RSP A20B, RSP A20C, and RSP A20D for pavement markers and traffic lines typical details.
2. Detail 9 traffic stripe shown, see project plans for traffic stripe details.

DIST	COUNTY	ROUTE	POST MILES TOTAL PROJECT	SHEET TOTAL NO. SHEETS
 REGISTERED CIVIL ENGINEER				
July 21, 2017 PLANS APPROVAL DATE				
				
<small>THE STATE OF CALIFORNIA OR ITS OFFICERS OR AGENTS SHALL NOT BE RESPONSIBLE FOR THE ACCURACY OR COMPLETENESS OF SCANNED COPIES OF THIS PLAN SHEET.</small>				

TO ACCOMPANY PLANS DATED _____

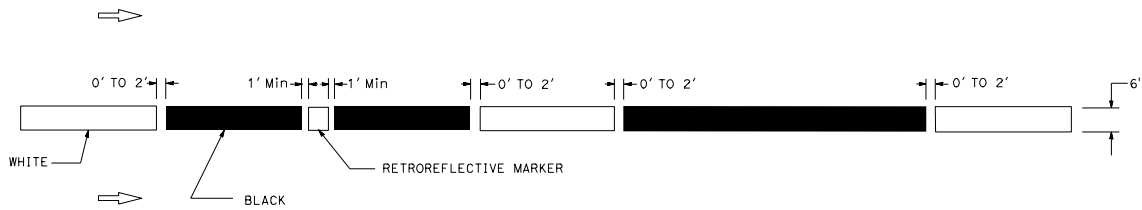

OPTION 2
TYPICAL LANE LINE CONTRAST DETAIL

See Note 2



OPTION 1
TYPICAL LANE LINE OR RIGHT EDGE LINE CONTRAST DETAIL

STATE OF CALIFORNIA
DEPARTMENT OF TRANSPORTATION

**PAVEMENT MARKERS
AND TRAFFIC LINES
TYPICAL DETAILS FOR CONTRAST STRIPING**

NO SCALE

RSP A20E DATED JULY 21, 2017 SUPERSEDES RSP A20E DATED JANUARY 20, 2017
THAT SUPPLEMENTS THE STANDARD PLANS BOOK DATED 2015.

REVISED STANDARD PLAN RSP A20E

DIST	COUNTY	ROUTE	POST MILES TOTAL PROJECT	SHEET NO.	TOTAL SHEETS
<i>Atifa Ferouz</i> REGISTERED CIVIL ENGINEER					
July 21, 2017 PLANS APPROVAL DATE					
No. C80402 Exp. 3-31-19 CIVIL					
<small>THE STATE OF CALIFORNIA OR ITS OFFICERS OR AGENTS SHALL NOT BE RESPONSIBLE FOR THE ACCURACY OR COMPLETENESS OF SCANNED COPIES OF THIS PLAN SHEET.</small>					

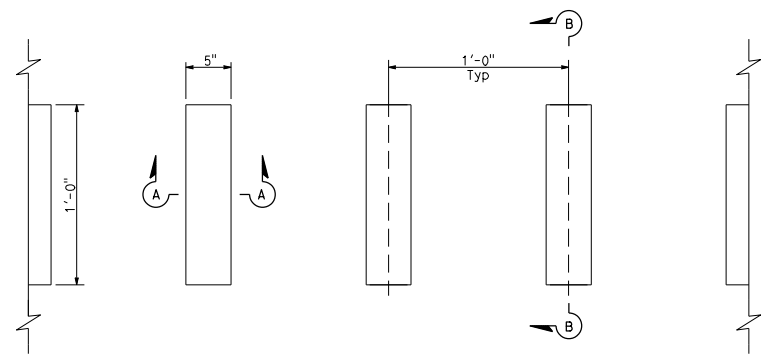
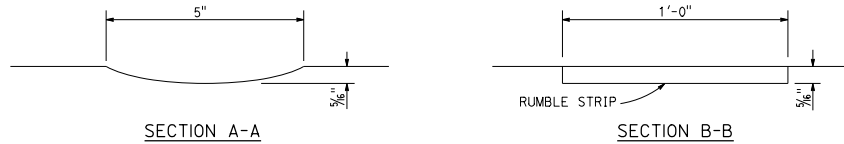

PLAN
GROUND-IN INDENTATIONS

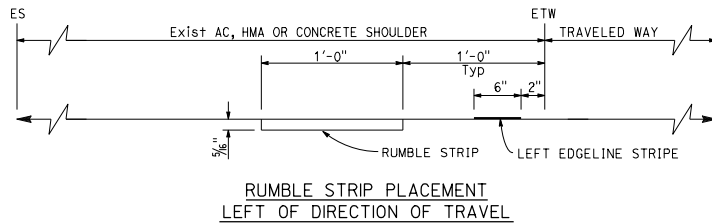

RUMBLE STRIP PLACEMENT
LEFT OF DIRECTION OF TRAVEL

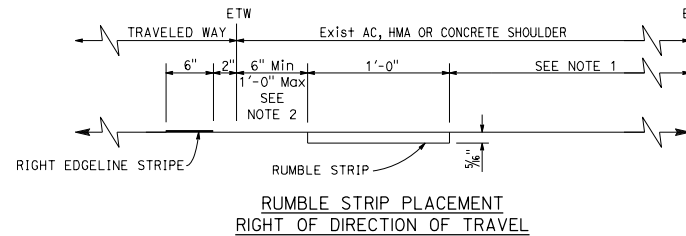

RUMBLE STRIP PLACEMENT
RIGHT OF DIRECTION OF TRAVEL

TYPICAL GROUND-IN RUMBLE STRIP
SHOULDER PLACEMENT

NOTES:

- Where bicycles are permitted, shoulder rumble strips should not be used right of direction of travel unless a minimum of 5'-0" of clear shoulder width for bicycle use is available between the rumble strip and the outer edge of the shoulder. Where bicycles are not permitted, a minimum of 4'-0" of distance is required between the rumble strip and the outer edge of the shoulder.
- Unless otherwise shown on the plans or specified in the special provisions, the 6" offset from the edge of traveled way to the edge of the rumble strip shall be used for rumble strip placement right of the direction of travel.

STATE OF CALIFORNIA
DEPARTMENT OF TRANSPORTATION
**SHOULDER RUMBLE STRIP
DETAILS
GROUND-IN INDENTATIONS**

NO SCALE

RSP A40B DATED JULY 21, 2017 SUPERSEDES STANDARD PLAN A40B
DATED OCTOBER 30, 2015 - PAGE 22 OF THE STANDARD PLANS BOOK DATED 2015.

REVISED STANDARD PLAN RSP A40B

2015 REVISED STANDARD PLAN RSP A40B

DIST	COUNTY	ROUTE	POST MILES TOTAL PROJECT	SHEET TOTAL SHEETS
<i>Atifa Ferouz</i> REGISTERED CIVIL ENGINEER				
July 21, 2017 PLANS APPROVAL DATE				
No. C80402 Exp. 3-31-19 CIVIL				
<small>THE STATE OF CALIFORNIA OR ITS OFFICERS OR AGENTS SHALL NOT BE RESPONSIBLE FOR THE ACCURACY OR COMPLETENESS OF SCANNED COPIES OF THIS PLAN SHEET.</small>				

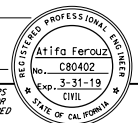

TO ACCOMPANY PLANS DATED _____

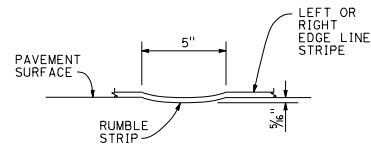

SECTION C-C

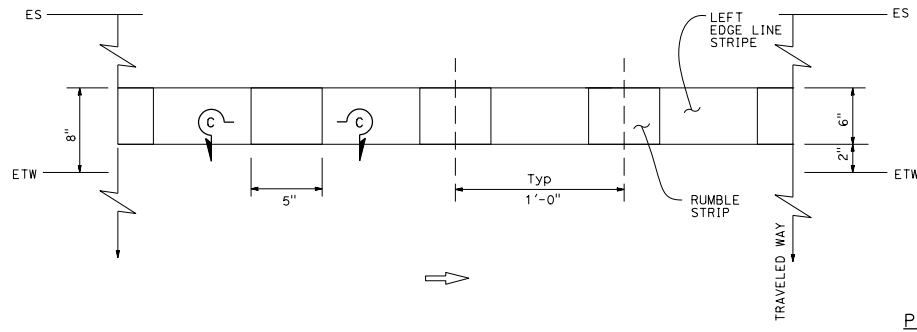

EDGE LINE RUMBLE STRIP PLACEMENT
LEFT OF DIRECTION OF TRAVEL

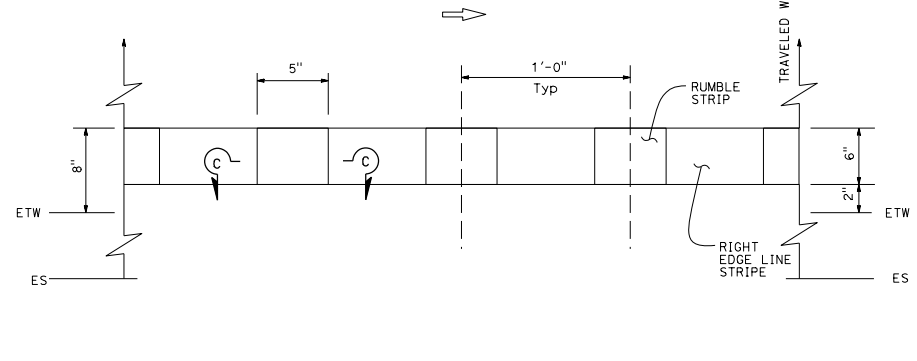

EDGE LINE RUMBLE STRIP PLACEMENT
RIGHT OF DIRECTION OF TRAVEL

PLAN

TYPICAL EDGE LINE RUMBLE STRIP PLACEMENT

STATE OF CALIFORNIA
DEPARTMENT OF TRANSPORTATION
**EDGE LINE RUMBLE STRIP
DETAILS
GROUND-IN INDENTATIONS**

NO SCALE

RSP A40C DATED JULY 21, 2017 SUPERSEDES RSP A40C DATED JULY 15, 2016
THAT SUPPLEMENTS THE STANDARD PLANS BOOK DATED 2015.

REVISED STANDARD PLAN RSP A40C

2015 REVISED STANDARD PLAN RSP A40C

DIST	COUNTY	ROUTE	POST MILES TOTAL PROJECT	SHEET TOTAL SHEETS

Atifa Ferouz
 REGISTERED CIVIL ENGINEER
 July 21, 2017
 PLANS APPROVAL DATE
 No. C80402
 Exp. 3-31-19
 CIVIL
 STATE OF CALIFORNIA

THE STATE OF CALIFORNIA OR ITS OFFICERS OR AGENTS SHALL NOT BE RESPONSIBLE FOR THE ACCURACY OR COMPLETENESS OF SCANNED COPIES OF THIS PLAN SHEET.

TO ACCOMPANY PLANS DATED _____

NOTE:

Detail 21 and Detail 5 traffic stripes shown, see project plans for traffic stripe details.

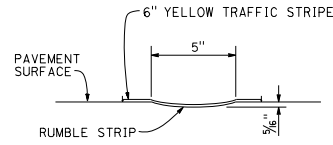

SECTION A-A

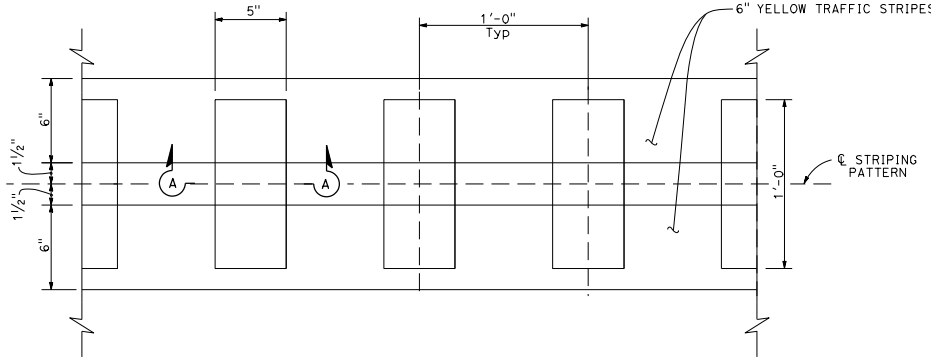

RUMBLE STRIP PLACEMENT IN NO PASSING ZONE

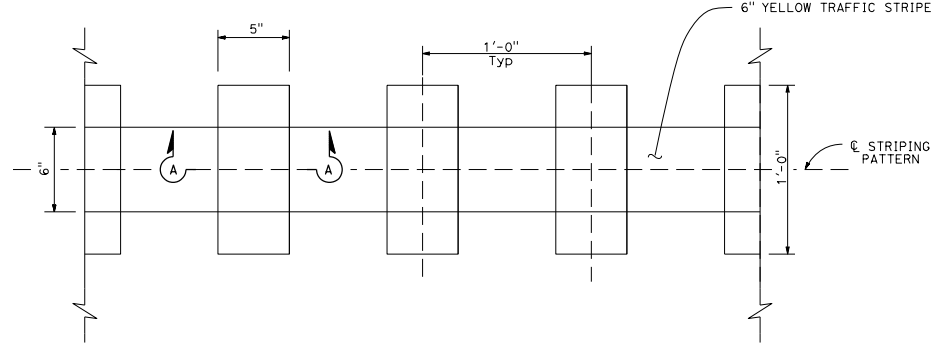

RUMBLE STRIP PLACEMENT IN PASSING ZONE

TYPICAL CENTERLINE RUMBLE STRIP PLACEMENT

STATE OF CALIFORNIA
DEPARTMENT OF TRANSPORTATION
**CENTERLINE RUMBLE STRIP
DETAILS
GROUND-IN INDENTATIONS**
NO SCALE

RSP A400 DATED JULY 21, 2017 SUPERSEDES RSP A400 DATED JULY 15, 2016
THAT SUPPLEMENTS THE STANDARD PLANS BOOK DATED 2015.

REVISED STANDARD PLAN RSP A400

2015 REVISED STANDARD PLAN RSP A400

DIST	COUNTY	ROUTE	POST MILES TOTAL PROJECT	SHEET NO.	TOTAL SHEETS

Atifa Ferouz
REGISTERED CIVIL ENGINEER

July 15, 2016
PLANS APPROVAL DATE

Atifa Ferouz
No. C80402
Exp. 3-31-17
REGISTERED PROFESSIONAL ENGINEER
CIVIL
STATE OF CALIFORNIA

THE STATE OF CALIFORNIA OR ITS OFFICERS OR AGENTS SHALL NOT BE RESPONSIBLE FOR THE ACCURACY OR COMPLETENESS OF SCANNED COPIES OF THIS PLAN SHEET.

TO ACCOMPANY PLANS DATED _____

LEGEND

..... RUMBLE STRIP (GROUND-IN)

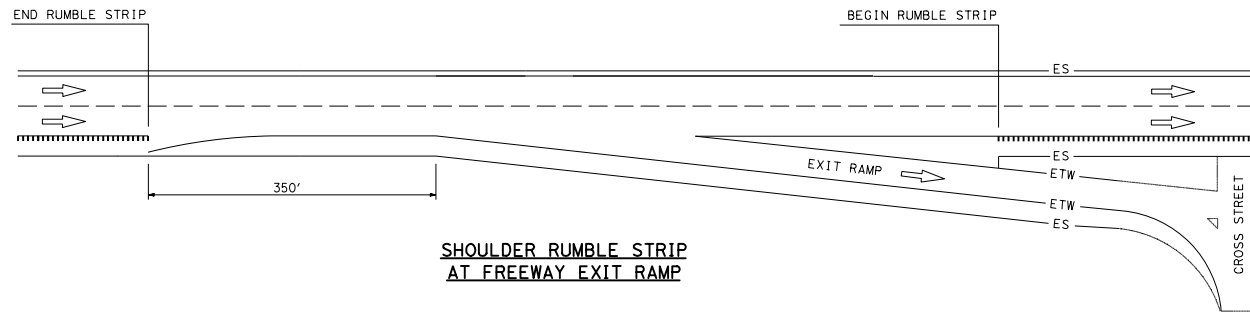

SHOULDER RUMBLE STRIP AT FREEWAY EXIT RAMP

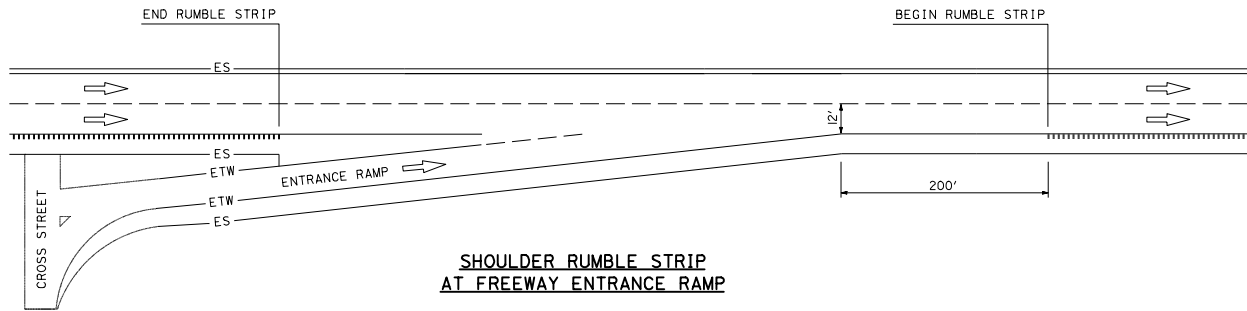

SHOULDER RUMBLE STRIP AT FREEWAY ENTRANCE RAMP

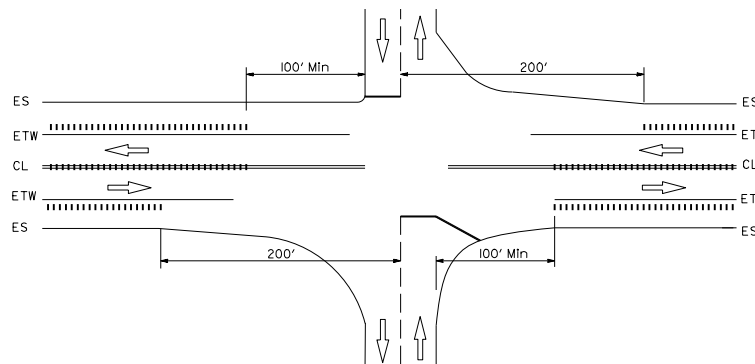

CENTERLINE AND SHOULDER RUMBLE STRIP AT GRADE INTERSECTION

STATE OF CALIFORNIA
DEPARTMENT OF TRANSPORTATION

**RUMBLE STRIP PLACEMENT AT
FREEWAY EXIT RAMP,
FREEWAY ENTRANCE RAMP,
AND INTERSECTIONS**

NO SCALE

RSP A40E DATED JULY 15, 2016 SUPPLEMENTS THE STANDARD PLANS BOOK DATED 2015.

REVISED STANDARD PLAN RSP A40E

2015 REVISED STANDARD PLAN RSP A40E

DIST	COUNTY	ROUTE	POST MILES TOTAL PROJECT	SHEET NO.	TOTAL SHEETS
<i>Atifa Ferouz</i> REGISTERED CIVIL ENGINEER					
July 15, 2016 PLANS APPROVAL DATE					
THE STATE OF CALIFORNIA OR ITS OFFICERS OR AGENTS SHALL NOT BE RESPONSIBLE FOR THE ACCURACY OR COMPLETENESS OF SCANNED COPIES OF THIS PLAN SHEET.					

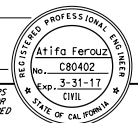

TO ACCOMPANY PLANS DATED _____

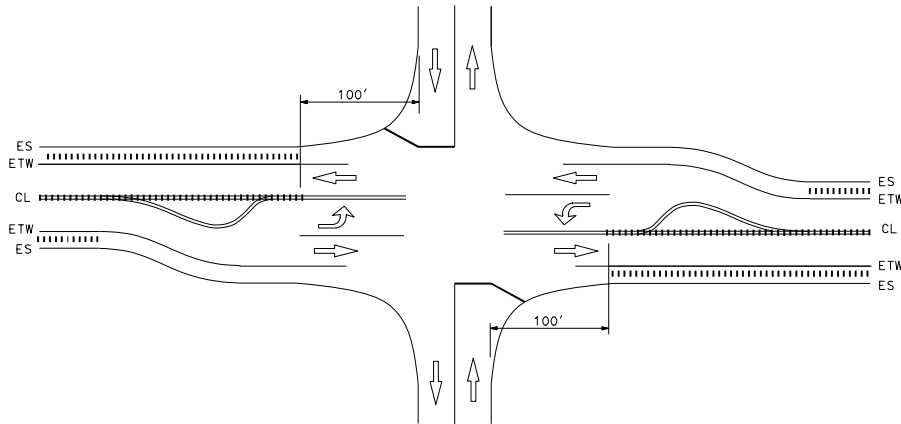

CENTERLINE AND SHOULDER RUMBLE STRIPS AT INTERSECTION WITH LEFT TURN POCKETS

LEGEND

- RUMBLE STRIPS (GROUND-IN)
- ||||| RAILROAD TRACKS

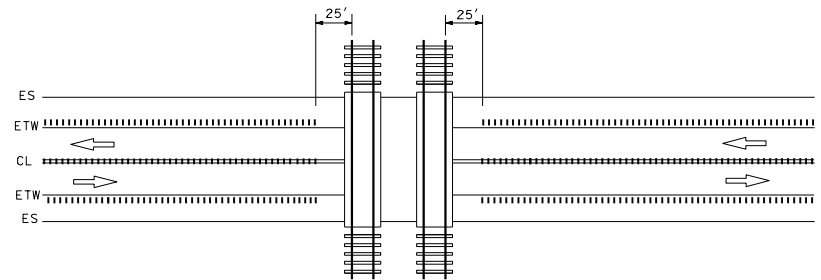

CENTERLINE AND SHOULDER RUMBLE STRIPS AT RAILROAD CROSSING

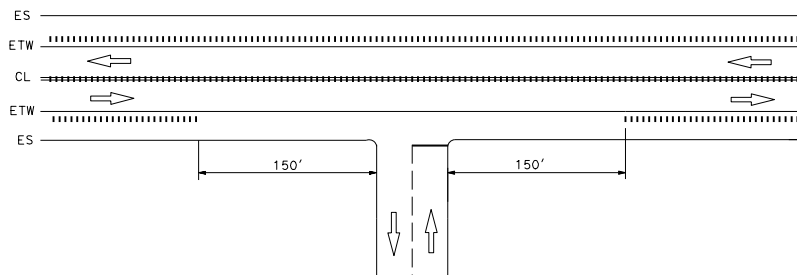

CENTERLINE AND SHOULDER RUMBLE STRIPS AT DRIVEWAY/PRIVATE ROAD APPROACH

STATE OF CALIFORNIA
DEPARTMENT OF TRANSPORTATION

RUMBLE STRIP PLACEMENT AT INTERSECTIONS WITH LEFT TURN POCKETS, RAILROAD CROSSINGS, PRIVATE ROADS, AND MAJOR DRIVEWAYS

NO SCALE

RSP A40F DATED JULY 15, 2016 SUPPLEMENTS THE STANDARD PLANS BOOK DATED 2015.

REVISED STANDARD PLAN RSP A40F

2015 REVISED STANDARD PLAN RSP A40F

Dist	COUNTY	ROUTE	POST MILES TOTAL PROJECT	SHEET No.	TOTAL SHEETS
Randell D. Hiatt REGISTERED CIVIL ENGINEER No. C50200 Exp. 6-30-19 CIVIL STATE OF CALIFORNIA					
PLANS APPROVAL DATE April 20, 2018					
THE STATE OF CALIFORNIA OR ITS OFFICERS OR AGENTS SHALL NOT BE RESPONSIBLE FOR THE ACCURACY OR COMPLETENESS OF SCANNED COPIES OF THIS PLAN SHEET.					

TO ACCOMPANY PLANS DATED _____

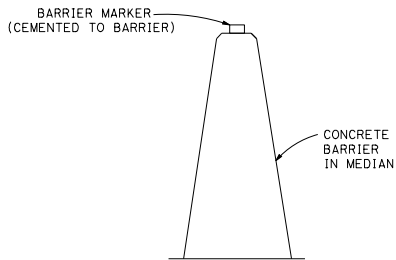

CONCRETE BARRIER TYPE 60M DELINEATION

See Note 5

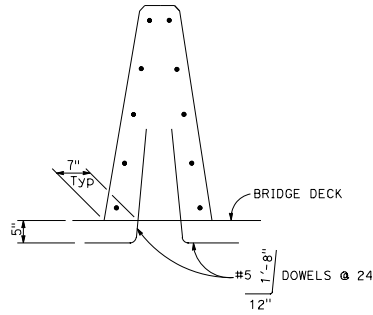

CONCRETE BARRIER TYPE 60MA

Details similar to Type 60M except as noted.

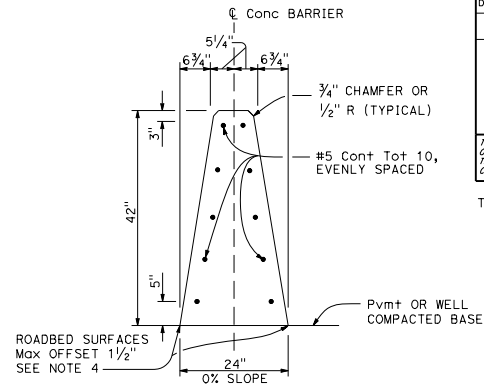

CONCRETE BARRIER TYPE 60M

NOTES:

- See Revised Standard Plan RSP A76B for details of Concrete Barrier Type 60M end anchors, connection to structures and transitions to Concrete Barrier Type 50 and Concrete Barrier Type 60MS.
- See Revised Standard Plan RSP A76C for Concrete Barrier Type 60M transitions at bridge column and sign pedestals.
- Where glare screen is required on Concrete Barrier Type 60M, use Concrete Barrier Type 60MG.
- Where roadbed offset is greater than 1 1/2", see Concrete Barrier Type 60MC.
- See Project Plans for barrier delineation locations.
- Reinforcing stirrup not required for roadbed offsets less than 1'-0".
- For roadbed surfaces offset greater than 1 1/2" and less than or equal to 3", no reinforcement required. For roadbed surfaces offset greater than 3" and less than or equal to 8", use two #4 Reinf at 3" above the lower roadbed surface. For roadbed surfaces offset greater than 8" and less than or equal to 12", use two #4 Reinf at 3" above the lower roadbed surface and two #4 Reinf at 8" above the lower roadbed surface. For roadbed surfaces offset greater than 12" and less than or equal to 36", use two #4 Reinf at 3" above the lower roadbed surface and two #4 Reinf at every 8" increment vertical spacing above the first two #4 Reinf.

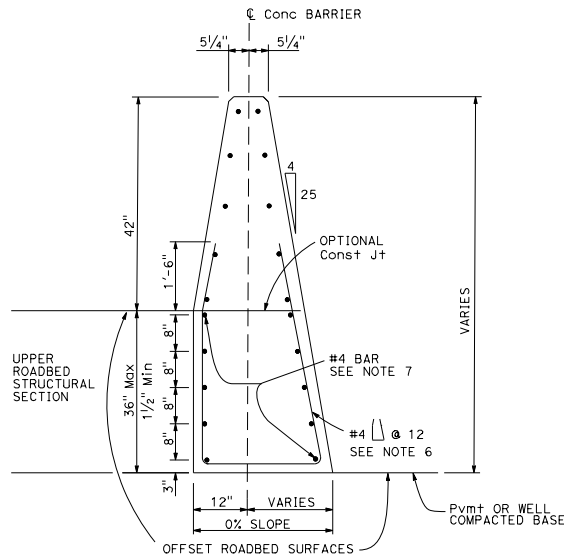

CONCRETE BARRIER TYPE 60MC

Details similar to Type 60M except as noted.
Use concrete barrier end anchor when necessary.
36" roadbed surfaces offset shown.

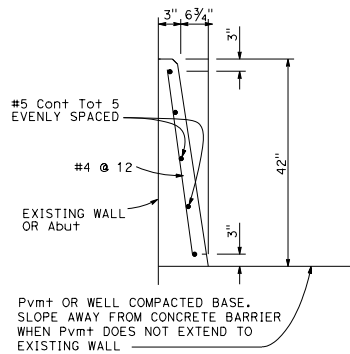

CONCRETE BARRIER TYPE 60MD

STATE OF CALIFORNIA
DEPARTMENT OF TRANSPORTATION
CONCRETE BARRIER TYPE 60M

NO SCALE

RSP A76A DATED APRIL 20, 2018 SUPERSEDES STANDARD PLAN A76A
DATED OCTOBER 30, 2015 - PAGE 37 OF THE STANDARD PLANS BOOK DATED 2015.

REVISED STANDARD PLAN RSP A76A

DIST	COUNTY	ROUTE	POST MILES TOTAL PROJECT	SHEET TOTAL SHEETS

Randell D. Hiatt
REGISTERED CIVIL ENGINEER

APRIL 20, 2018
PLANS APPROVAL DATE

REGISTERED PROFESSIONAL ENGINEER
No. C50200
Exp. 6-30-19
CIVIL
STATE OF CALIFORNIA

THE STATE OF CALIFORNIA OR ITS OFFICERS OR AGENTS SHALL NOT BE RESPONSIBLE FOR THE ACCURACY OR COMPLETENESS OF SCANNED COPIES OF THIS PLAN SHEET.

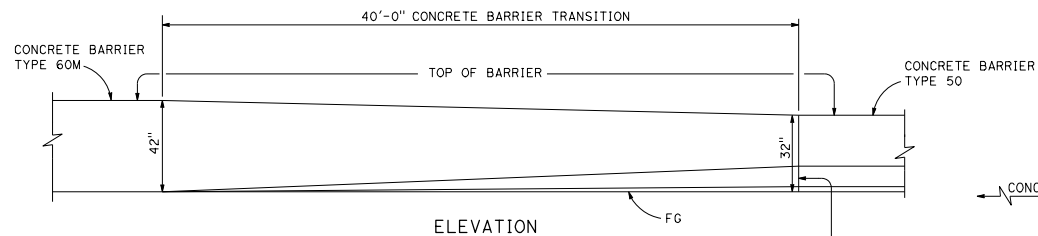

ELEVATION

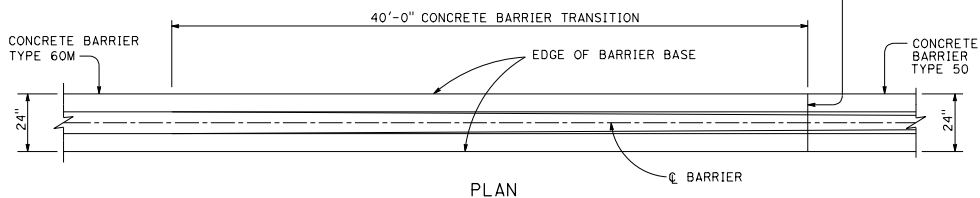

PLAN

TRANSITION CONCRETE BARRIER TYPE 60M TO CONCRETE BARRIER TYPE 50

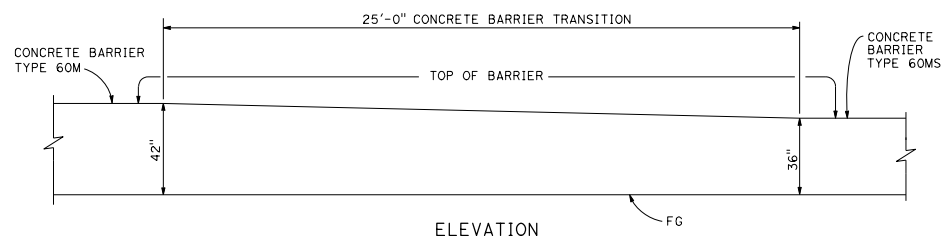

ELEVATION

TRANSITION CONCRETE BARRIER TYPE 60M TO CONCRETE BARRIER TYPE 60MS

NOTES:

1. See Revised Standard Plan RSP A76A for Concrete Barrier Type 60M and Type 60MA.
2. Footing monolithic or doweled with 2-#8 x 8" @ 2'-0". The footing is required at concrete barrier ends and at interruptions in concrete barrier.
3. 10" concrete barrier footing extends 10' back from structure.
4. See Revised Standard Plan RSP A78I for transition to Thrie Beam Barrier.

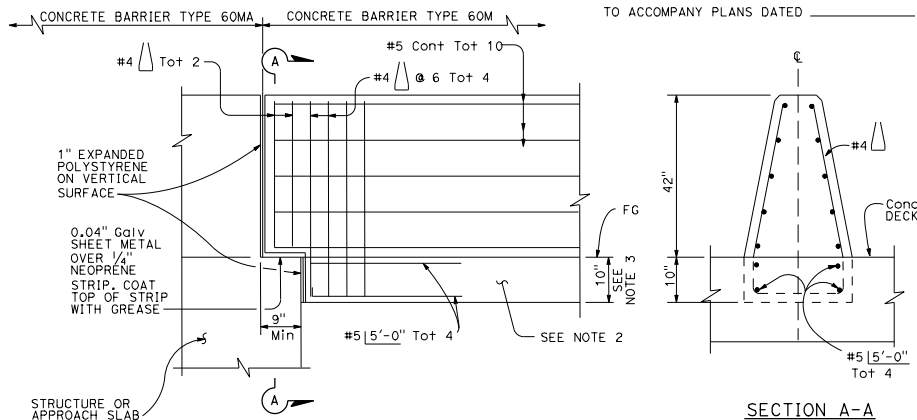

CONCRETE BARRIER TYPE 60M CONNECTION TO STRUCTURE

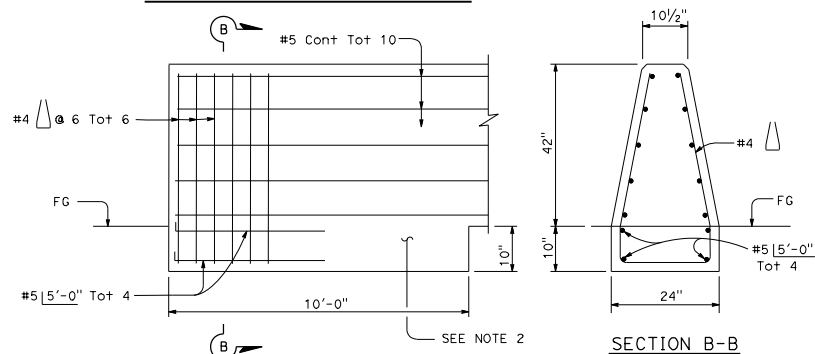

CONCRETE BARRIER TYPE 60M END ANCHORAGE

STATE OF CALIFORNIA
DEPARTMENT OF TRANSPORTATION
CONCRETE BARRIER TYPE 60M
NO SCALE

RSP A76B DATED APRIL 20, 2018 SUPERSEDES STANDARD PLAN A76B
DATED OCTOBER 30, 2015 - PAGE 38 OF THE STANDARD PLANS BOOK DATED 2015.

REVISED STANDARD PLAN RSP A76B

2015 REVISED STANDARD PLAN RSP A76B

DIST	COUNTY	ROUTE	POST MILES TOTAL PROJECT	SHEET NO.	TOTAL SHEETS

Stanley P. Johnson
 REGISTERED CIVIL ENGINEER
 No. CS7793
 APRIL 20, 2018
 PLANS APPROVAL DATE
 THE STATE OF CALIFORNIA OR ITS OFFICERS OR AGENTS SHALL NOT BE RESPONSIBLE FOR THE ACCURACY OR COMPLETENESS OF SCANNED COPIES OF THIS PLAN SHEET.

TO ACCOMPANY PLANS DATED _____

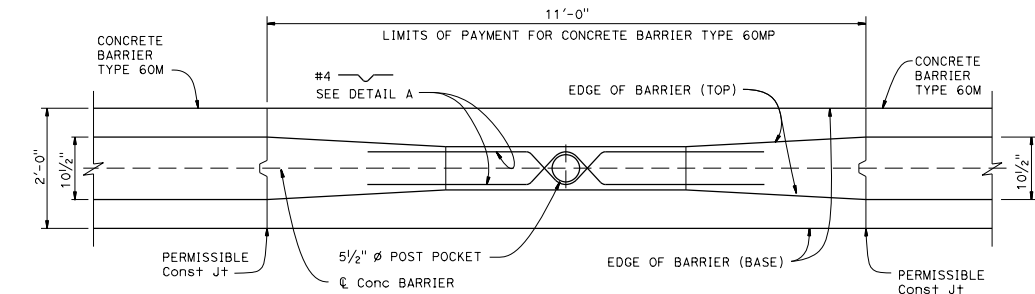

PLAN

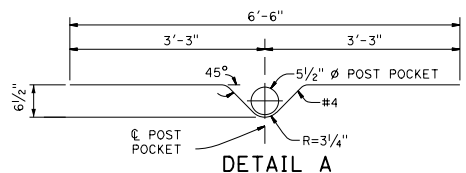

DETAIL A

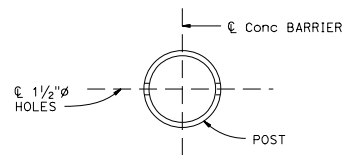

DETAIL B

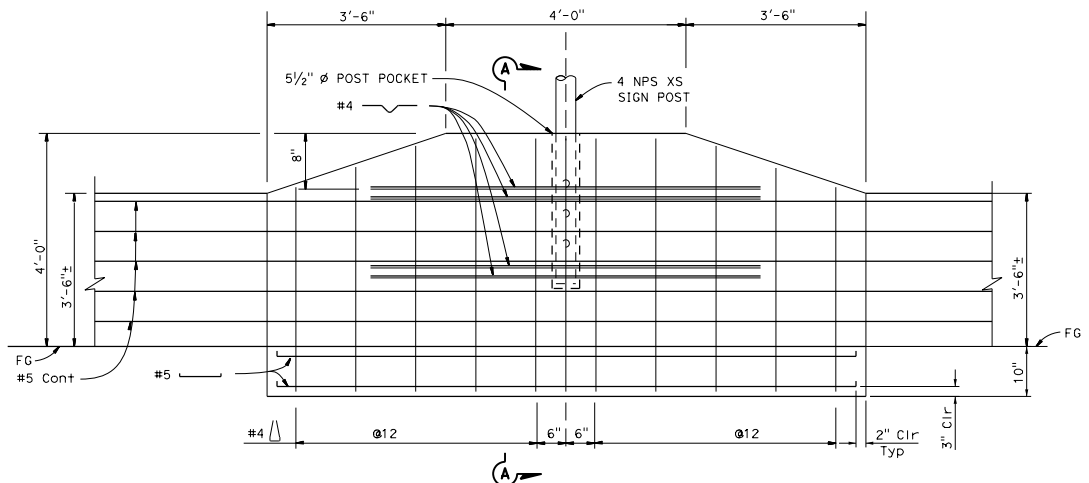

ELEVATION

NOTE:
For Type 60M Barrier cross section see Revised Standard Plan RSP A76A

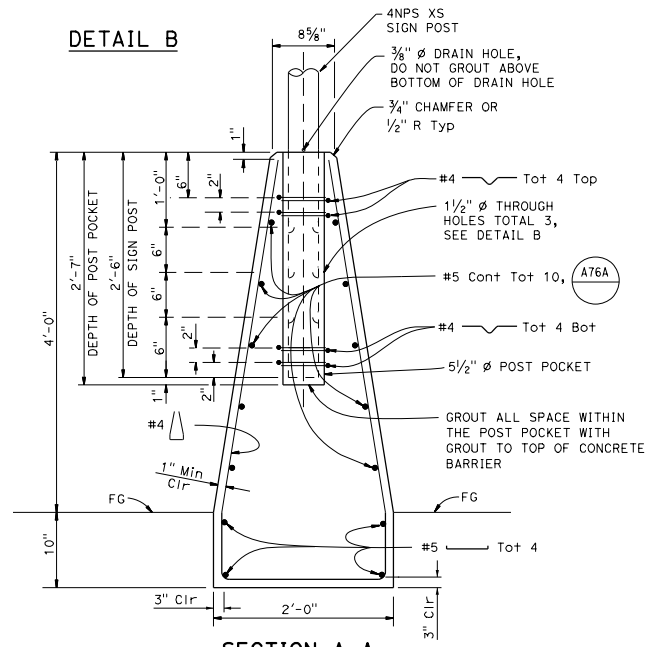

SECTION A-A

STATE OF CALIFORNIA
DEPARTMENT OF TRANSPORTATION
CONCRETE BARRIER TYPE 60MP
NO SCALE

RSP A76BA DATED APRIL 20, 2018 SUPERSEDES RSP A76BA DATED JULY 15, 2016 THAT SUPPLEMENTS THE STANDARD PLANS BOOK DATED 2015.

REVISED STANDARD PLAN RSP A76BA

2015 REVISED STANDARD PLAN RSP A76BA

DIST	COUNTY	ROUTE	POST MILES TOTAL PROJECT	SHEET NO.	TOTAL SHEETS

Stanley P. Johnson
 REGISTERED CIVIL ENGINEER
 No. CS7793
 July 15, 2016
 PLANS APPROVAL DATE
 THE STATE OF CALIFORNIA OR ITS OFFICERS OR AGENTS SHALL NOT BE RESPONSIBLE FOR THE ACCURACY OR COMPLETENESS OF SCANNED COPIES OF THIS PLAN SHEET.

REGISTERED PROFESSIONAL ENGINEER
 Stanley P. Johnson
 No. CS7793
 Exp. 3-31-18
 CIVIL
 STATE OF CALIFORNIA

TO ACCOMPANY PLANS DATED _____

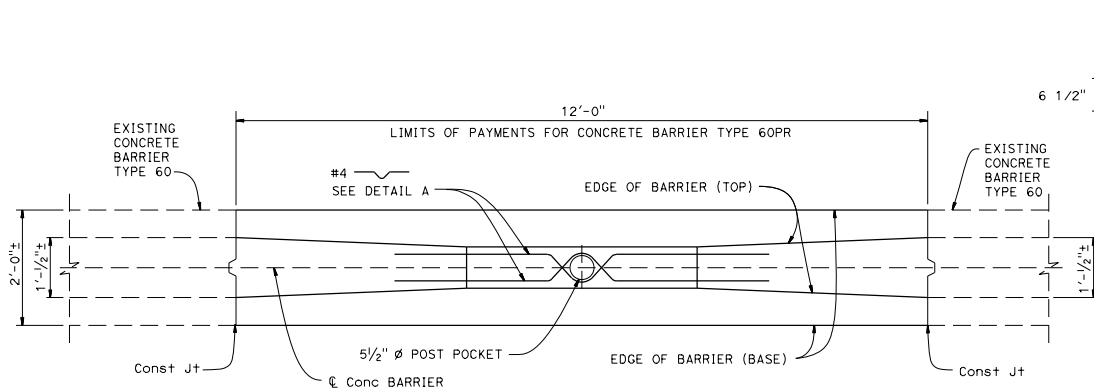

PLAN

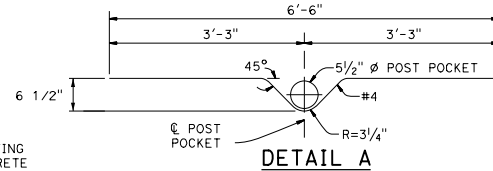

DETAIL A

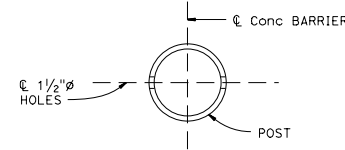

DETAIL B

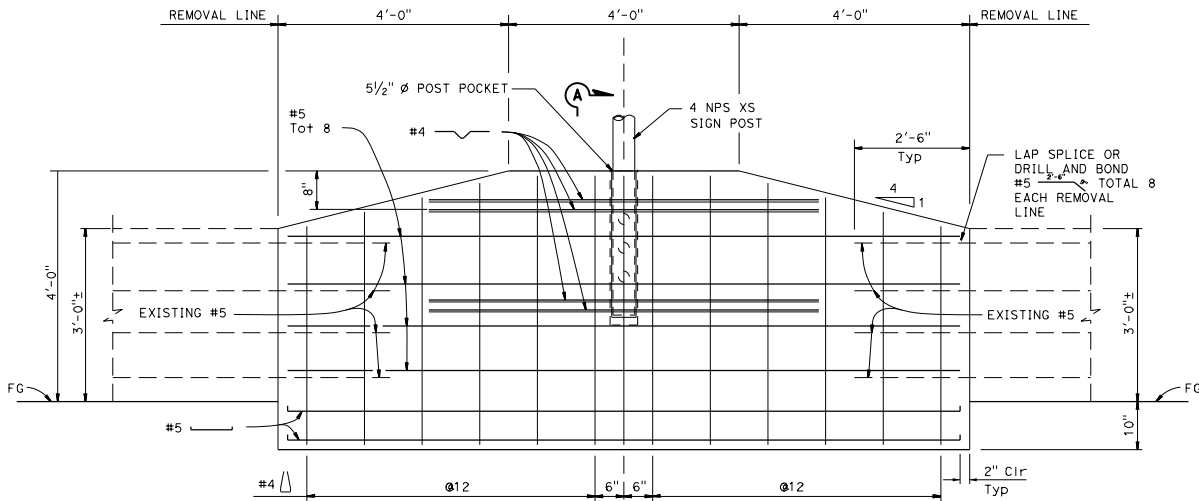

ELEVATION

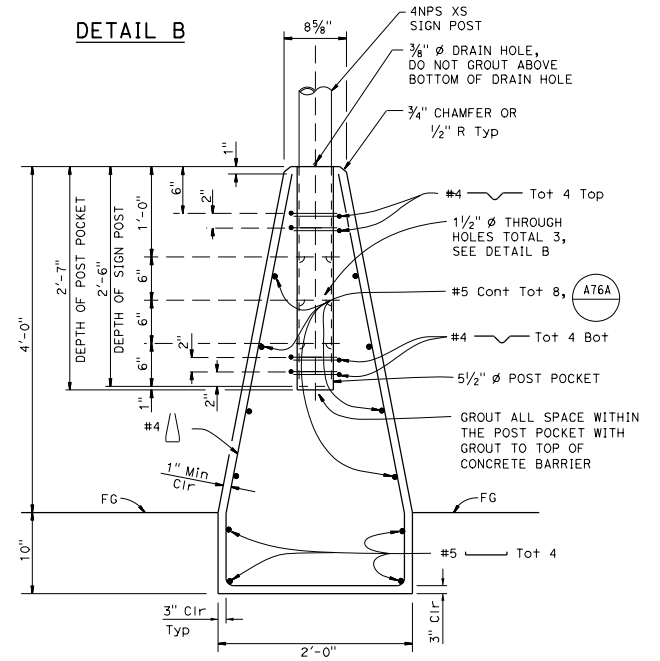

SECTION A-A

NOTE:
 THE CONTRACTOR MUST VERIFY ALL CONTROLLING FIELD DIMENSIONS BEFORE ORDERING OR FABRICATING ANY MATERIAL.

STATE OF CALIFORNIA
 DEPARTMENT OF TRANSPORTATION
CONCRETE BARRIER TYPE 60PR
 NO SCALE

RSP A76BB DATED JULY 15, 2016 SUPPLEMENTS THE STANDARD PLANS BOOK DATED 2015.

REVISED STANDARD PLAN RSP A76BB

2015 REVISED STANDARD PLAN RSP A76BB

DIST	COUNTY	ROUTE	POST MILES TOTAL PROJECT	SHEET NO.	TOTAL SHEETS

Stanley P. Johnson
 REGISTERED CIVIL ENGINEER
 No. CS7793
 STATE OF CALIFORNIA
 CIVIL
 No. 3-31-18

July 15, 2016
 PLANS APPROVAL DATE
 THE STATE OF CALIFORNIA OR ITS OFFICERS OR AGENTS SHALL NOT BE RESPONSIBLE FOR THE ACCURACY OR COMPLETENESS OF SCANNED COPIES OF THIS PLAN SHEET.

TO ACCOMPANY PLANS DATED _____

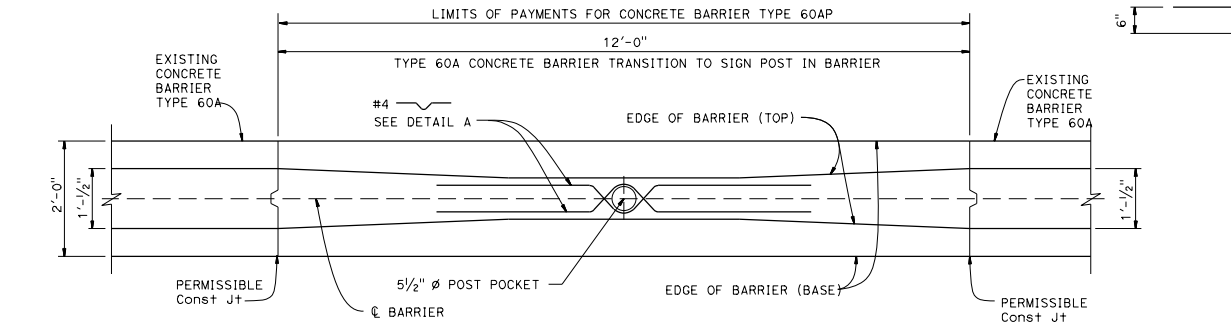

PLAN

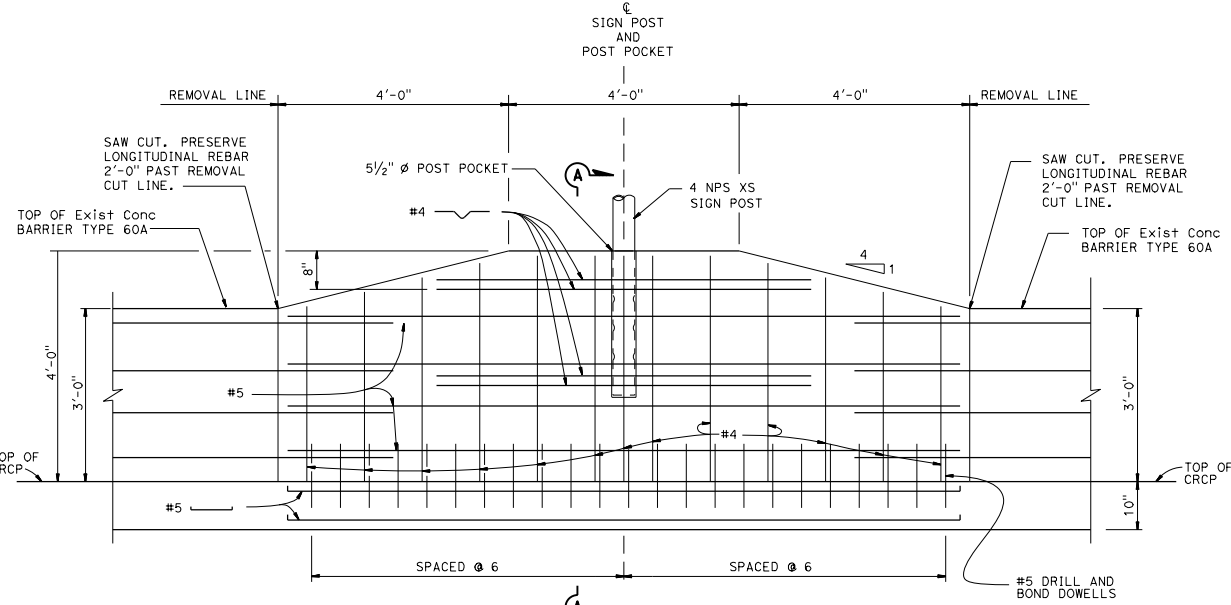

ELEVATION

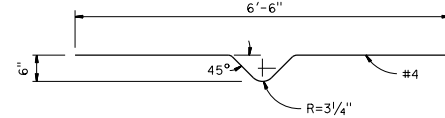

DETAIL A

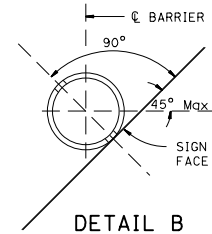

DETAIL B

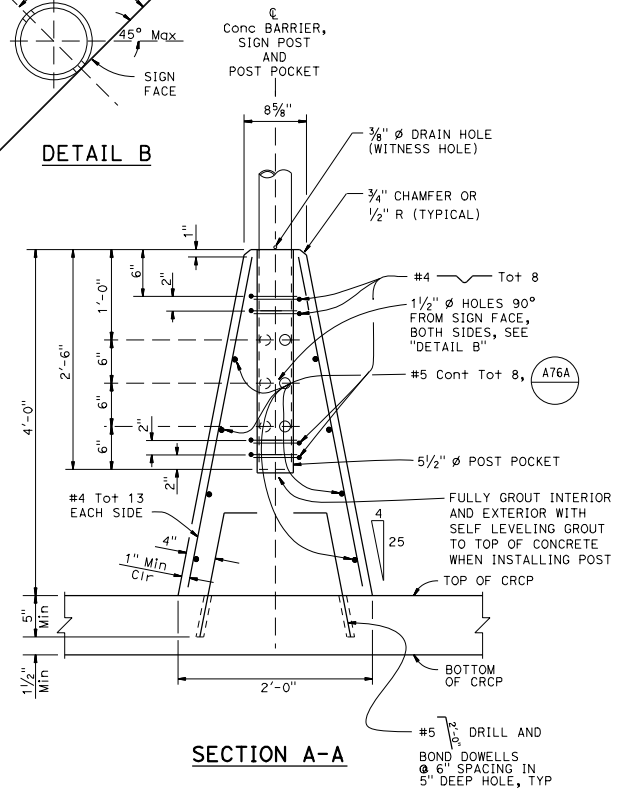

SECTION A-A

STATE OF CALIFORNIA
DEPARTMENT OF TRANSPORTATION
CONCRETE BARRIER TYPE 60AP
NO SCALE

RSP A76BC DATED JULY 15, 2016 SUPPLEMENTS THE STANDARD PLANS BOOK DATED 2015.

REVISED STANDARD PLAN RSP A76BC

2015 REVISED STANDARD PLAN RSP A76BC

DIST	COUNTY	ROUTE	POST MILES TOTAL PROJECT	SHEET No.	TOTAL SHEETS

Randell D. Hiatt
REGISTERED CIVIL ENGINEER

PLANS APPROVAL DATE: April 20, 2018
No. C50200
Exp. 6-30-19
CIVIL
STATE OF CALIFORNIA

THE STATE OF CALIFORNIA OR ITS OFFICERS OR AGENTS SHALL NOT BE RESPONSIBLE FOR THE ACCURACY OR COMPLETENESS OF SCANNED COPIES OF THIS PLAN SHEET.

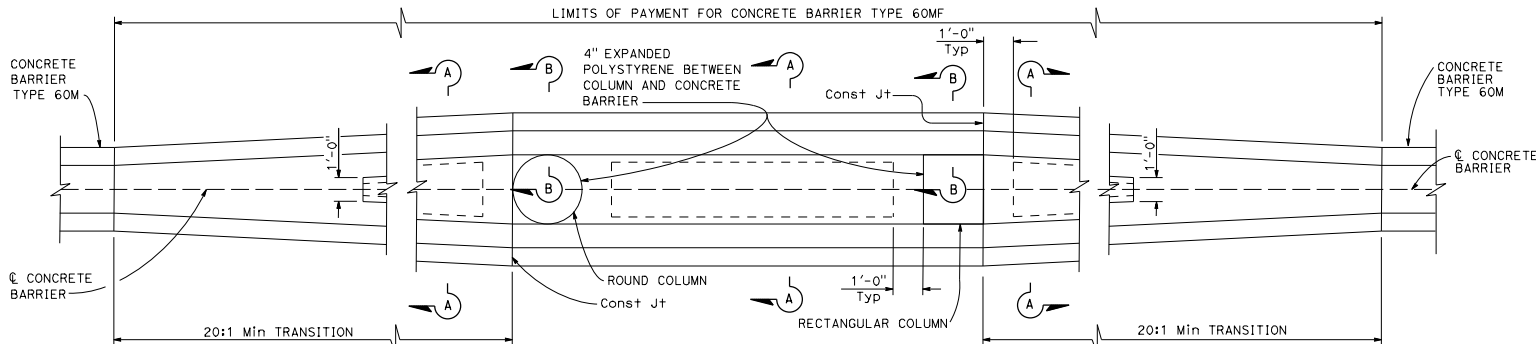

TRANSITION AT BRIDGE COLUMNS

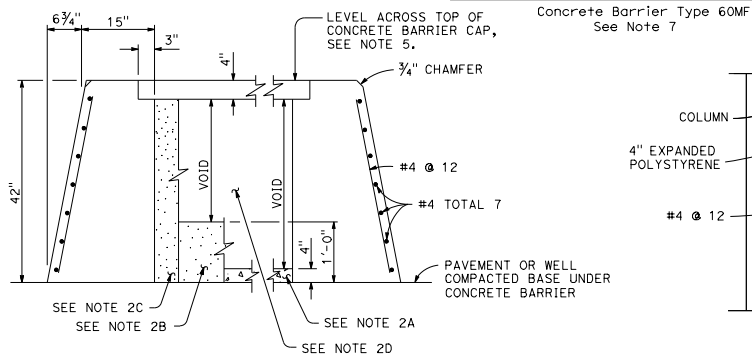

SECTION A-A

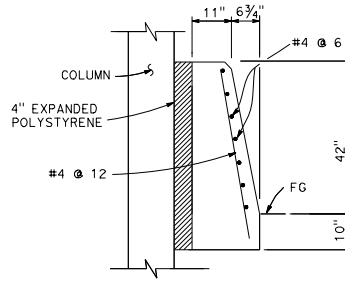

SECTION B-B

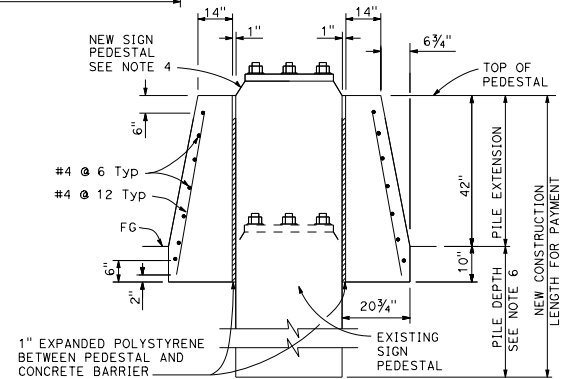

SECTION C-C

NOTES:

- See Revised Standard Plan RSP A76A for Concrete Barrier Type 60M.
- Contractor options for fill between concrete barrier walls:
A. Place 4" PCC at base between concrete barrier walls.
B. Place 1'-0" of granular material at base between walls.
C. Place granular material from base to bottom of 4" cap.
D. Monolithic concrete with foam blockouts is not permitted.
- Reinforcing steel shall extend continuous through construction joints.
- See Overhead Sign plans for sign pedestal elevations on new construction.
- Adjust height of concrete barrier wall on low side of offset or superelevated roadways to provide level grade across top of concrete barrier cap.
- See Overhead Signs Standard Plan Pile Foundation Tables.
- All locations with limited shoulder width available for barrier, see Revised Standard Plan RSP A76F for use of Concrete Barrier Type 60MGF.

STATE OF CALIFORNIA
DEPARTMENT OF TRANSPORTATION

CONCRETE BARRIER TYPE 60MF

NO SCALE

RSP A76C DATED APRIL 20, 2018 SUPERSEDES STANDARD PLAN A76C
DATED OCTOBER 30, 2015 - PAGE 39 OF THE STANDARD PLANS BOOK DATED 2015.

REVISED STANDARD PLAN RSP A76C

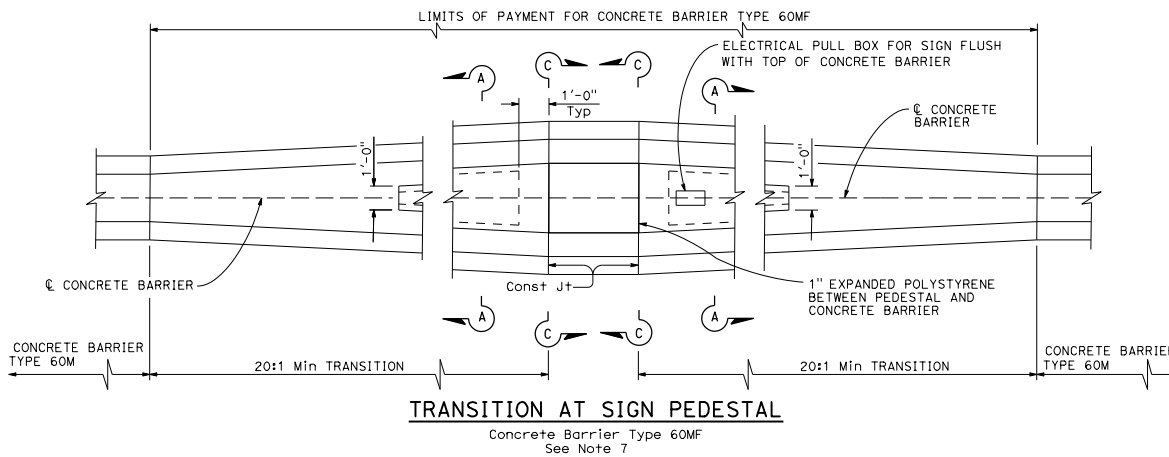

TRANSITION AT SIGN PEDESTAL

Concrete Barrier Type 60MF
See Note 7

Dist	COUNTY	ROUTE	POST MILES TOTAL PROJECT	SHEET No.	TOTAL SHEETS
<i>Randell D. Hiatt</i> REGISTERED CIVIL ENGINEER					
April 20, 2018 PLANS APPROVAL DATE					
No. C50200 Exp. 6-30-19 CIVIL STATE OF CALIFORNIA					

TO ACCOMPANY PLANS DATED _____

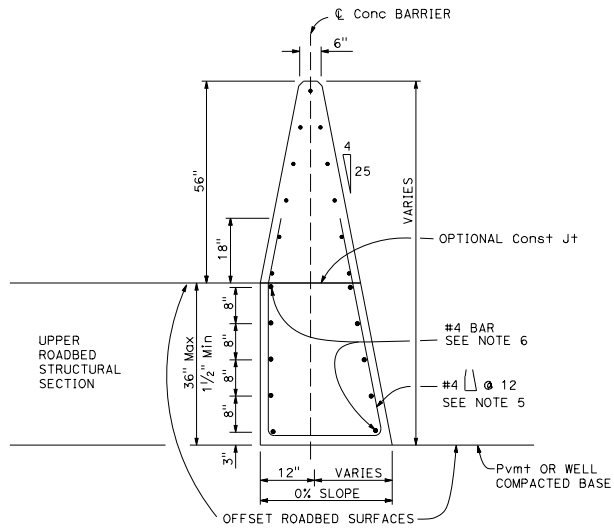

CONCRETE BARRIER TYPE 60MGC

Details similar to Type 60MG except as noted.
36" roadbed surfaces offset shown.

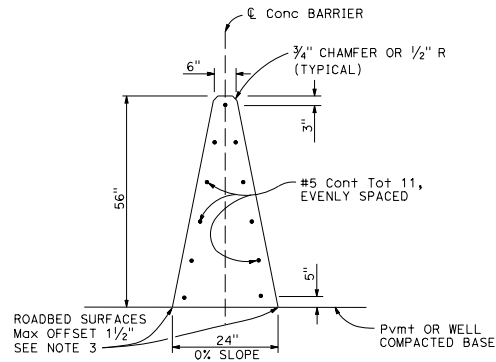

CONCRETE BARRIER TYPE 60MG

(Monolithic concrete glare screen/barrier)

NOTES:

1. See Revised Standard Plan RSP A76E for details of Concrete Barrier Type 60MG end anchors, connection to structures and transitions to Concrete Barrier Type 60M.
2. See Revised Standard Plan RSP A76F for Concrete Barrier Type 60MG transitions at bridge column and sign pedestals.
3. Where roadbed offset is greater than 1 1/2", see Concrete Barrier Type 60MGC.
4. Barrier delineation to be used when required by the Special Provisions.
5. Reinforcing stirrup not required for offsets less than 1'-0".
6. For roadbed surfaces offset greater than 1 1/2" and less than or equal to 3", no reinforcement required. For roadbed surfaces offset greater than 3" and less than or equal to 8", use two #4 Reinf at 3" above the lower roadbed surface. For roadbed surfaces offset greater than 8" and less than or equal to 12", use two #4 Reinf at 3" above the lower roadbed surface and two #4 Reinf at 8" above the lower roadbed surface. For roadbed surfaces offset greater than 12" and less than or equal to 36", use two #4 Reinf at 3" above the lower roadbed surface and two #4 Reinf at every 8" increment vertical spacing above the first two #4 Reinf.

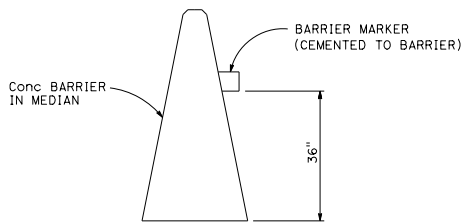

CONCRETE BARRIER TYPE 60MG DELINEATION

See Note 4

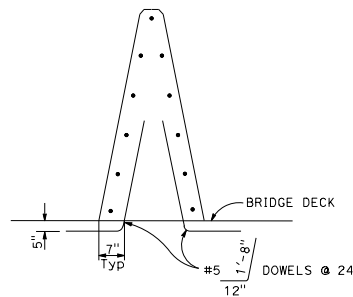

CONCRETE BARRIER TYPE 60MGA

Details similar to Type 60MG except as noted.

STATE OF CALIFORNIA
DEPARTMENT OF TRANSPORTATION

CONCRETE BARRIER TYPE 60MG

NO SCALE

RSP A76D DATED APRIL 20, 2018 SUPERSEDES STANDARD PLAN A76D
DATED OCTOBER 30, 2015 - PAGE 40 OF THE STANDARD PLANS BOOK DATED 2015.

REVISED STANDARD PLAN RSP A76D

DIST	COUNTY	ROUTE	POST MILES TOTAL PROJECT	SHEET NO.	TOTAL SHEETS

Randell D. Hiatt
REGISTERED CIVIL ENGINEER

April 20, 2018
PLANS APPROVAL DATE

REGISTERED PROFESSIONAL ENGINEER
No. C50200
Exp. 6-30-19
CIVIL
STATE OF CALIFORNIA

THE STATE OF CALIFORNIA OR ITS OFFICERS OR AGENTS SHALL NOT BE RESPONSIBLE FOR THE ACCURACY OR COMPLETENESS OF SCANNED COPIES OF THIS PLAN SHEET.

TO ACCOMPANY PLANS DATED _____

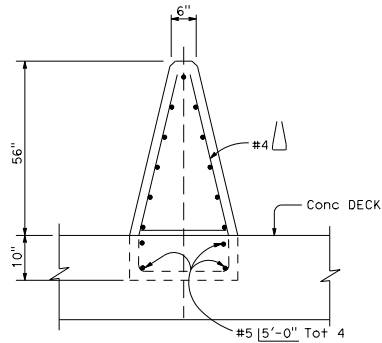
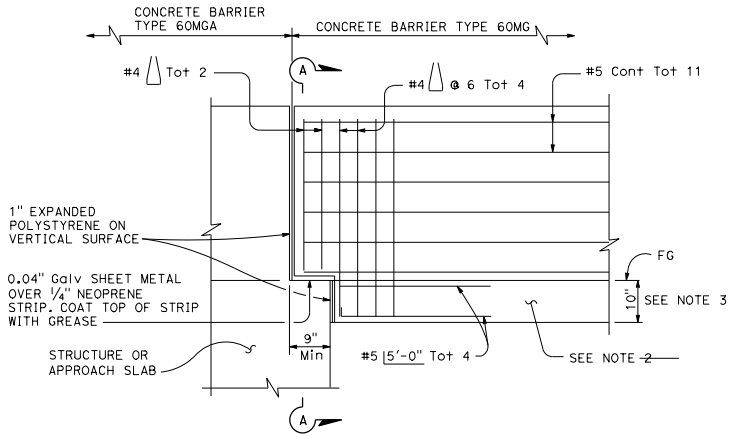

SECTION A-A

NOTES:

1. See Revised Standard Plan RSP A76D for Concrete Barrier Type 60MG and Type 60MGA.
2. Footing monolithic or doweled with 2-#8 x 8" @ 2'-0". The footing is required at concrete barrier ends and at interruptions in concrete barrier.
3. 10' concrete barrier footing extends 10' back from structure.
4. See Revised Standard Plan RSP A78I for transition to Thrie Beam Barrier.

CONCRETE BARRIER TYPE 60MG CONNECTION TO STRUCTURE

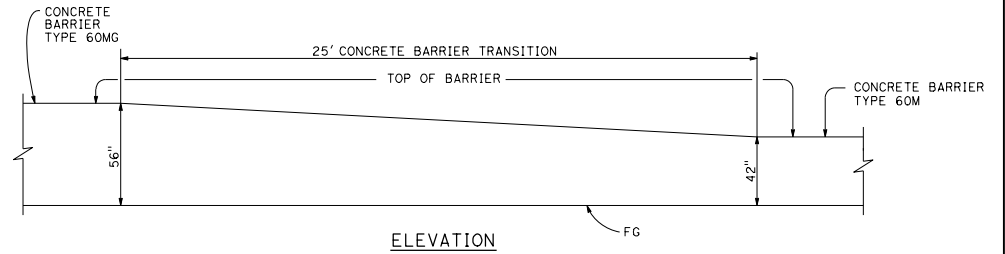

ELEVATION

TRANSITION CONCRETE BARRIER TYPE 60MG TO CONCRETE BARRIER TYPE 60M

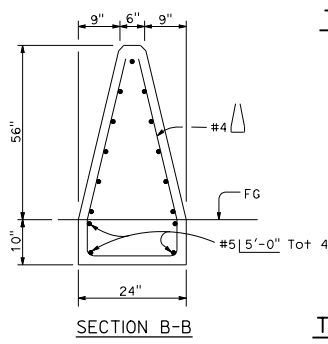
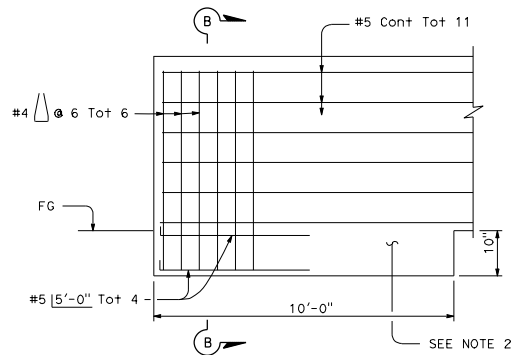

SECTION B-B

CONCRETE BARRIER TYPE 60MG END ANCHORAGE

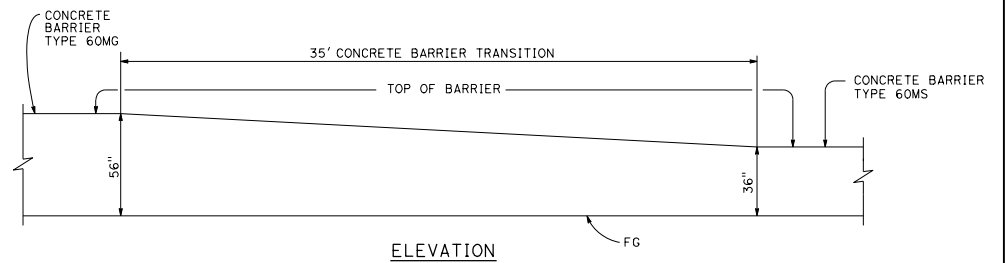

ELEVATION

TRANSITION CONCRETE BARRIER TYPE 60MG TO CONCRETE BARRIER TYPE 60MS

STATE OF CALIFORNIA
DEPARTMENT OF TRANSPORTATION
CONCRETE BARRIER TYPE 60MG

NO SCALE

RSP A76E DATED APRIL 20, 2018 SUPERSEDES STANDARD PLAN A76E
DATED OCTOBER 30, 2015 - PAGE 41 OF THE STANDARD PLANS BOOK DATED 2015.

REVISED STANDARD PLAN RSP A76E

2015 REVISED STANDARD PLAN RSP A76E

DIST	COUNTY	ROUTE	POST MILES TOTAL PROJECT	SHEET TOTAL SHEETS

Randell D. Hiatt
REGISTERED CIVIL ENGINEER

April 20, 2018
PLANS APPROVAL DATE

REGISTERED PROFESSIONAL ENGINEER
No. C50200
Exp. 6-30-19
CIVIL
STATE OF CALIFORNIA

THE STATE OF CALIFORNIA OR ITS OFFICERS OR AGENTS SHALL NOT BE RESPONSIBLE FOR THE ACCURACY OR COMPLETENESS OF SCANNED COPIES OF THIS PLAN SHEET.

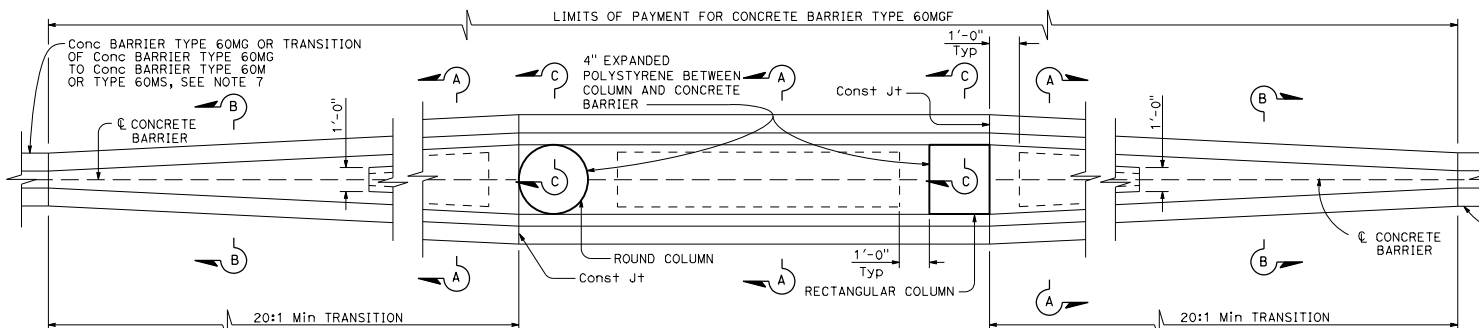

TRANSITION AT BRIDGE COLUMNS
Concrete Barrier Type 60MGF

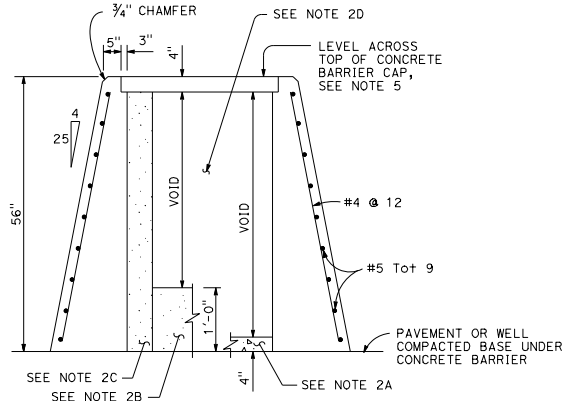

SECTION A-A

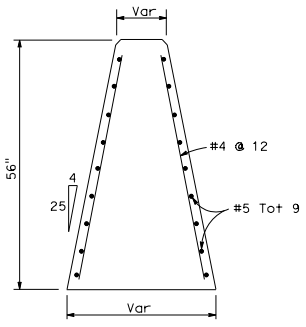

SECTION B-B

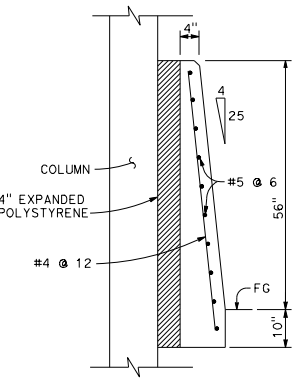

SECTION C-C

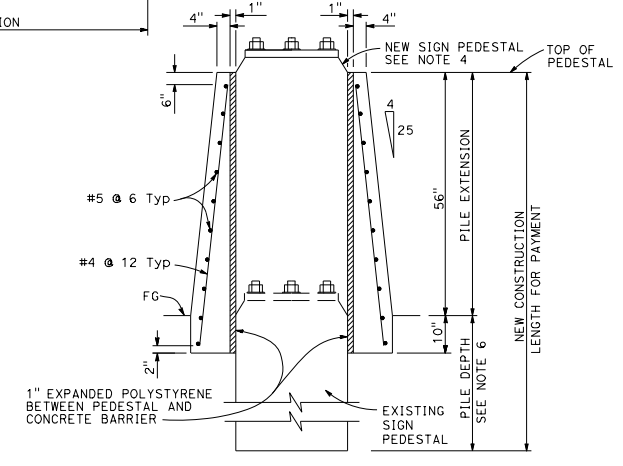

SECTION D-D

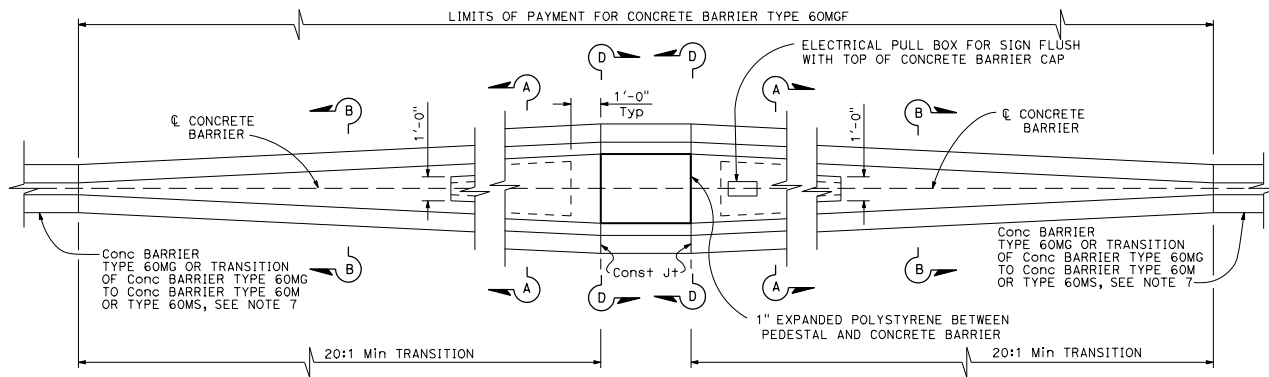

TRANSITION AT SIGN PEDESTAL
Concrete Barrier Type 60MGF

NOTES:

- See Revised Standard Plan RSP A76D for Concrete Barrier Type 60MG.
- Contractor options for fill between concrete barrier walls:
 - A. Place 4" PCC at base between concrete barrier walls.
 - B. Place 1'-0" of granular material at base between walls.
 - C. Place granular material from base to bottom of 4" cap.
 - D. Monolithic concrete with foam blockouts is not permitted.
- Reinforcing steel shall extend continuous through construction joints.
- See Overhead Signs Standard Plan for sign pedestal elevations on new construction.
- Adjust height of concrete barrier wall on low side of offset or super-elevated roadways to provide level grade across top of concrete barrier cap.
- See Overhead Signs Standard Plan Pile Foundation Tables.
- See Revised Standard Plan RSP A76E for concrete barrier transitions.

STATE OF CALIFORNIA
DEPARTMENT OF TRANSPORTATION
CONCRETE BARRIER TYPE 60MGF
NO SCALE

RSP A76F DATED APRIL 20, 2018 SUPERSEDES STANDARD PLAN A76F DATED OCTOBER 30, 2015 - PAGE 42 OF THE STANDARD PLANS BOOK DATED 2015.

REVISED STANDARD PLAN RSP A76F

2015 REVISED STANDARD PLAN RSP A76F

Dist	County	ROUTE	POST MILES TOTAL PROJECT	SHEET No.	TOTAL SHEETS

Randell D. Hiatt
REGISTERED CIVIL ENGINEER

April 20, 2018
PLANS APPROVAL DATE

REGISTERED PROFESSIONAL ENGINEER
No. C50200
Exp. 6-30-19
CIVIL
STATE OF CALIFORNIA

THE STATE OF CALIFORNIA OR ITS OFFICERS OR AGENTS SHALL NOT BE RESPONSIBLE FOR THE ACCURACY OR COMPLETENESS OF SCANNED COPIES OF THIS PLAN SHEET.

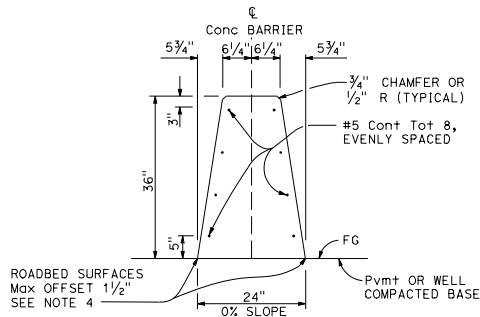

CONCRETE BARRIER TYPE 60MS

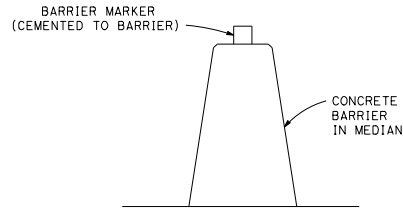

CONCRETE BARRIER TYPE 60MS DELINEATION

See Note 5

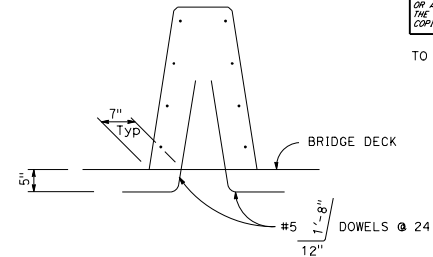

CONCRETE BARRIER TYPE 60MSA

Details similar to Type 60MS except as noted.

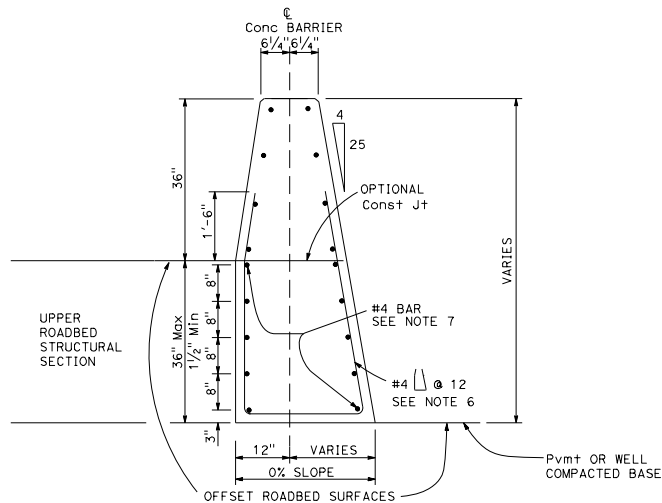

CONCRETE BARRIER TYPE 60MSC

Details similar to Type 60MS except as noted.
Use concrete barrier end anchor when necessary.
36" roadbed surfaces offset shown.

NOTES:

- See Revised Standard Plan RSP A76H for details of Concrete Barrier Type 60MS end anchors, connection to structures and transitions to Concrete Barrier Type 50.
- See Revised Standard Plan RSP A76I for Concrete Barrier Type 60MS transitions at bridge column and sign pedestals.
- Where glare screen is required on top of concrete barrier, use Concrete Barrier Type 60MG.
- Where roadbed offset is greater than 1 1/2" see Concrete Barrier Type 60MSC.
- Barrier delineation to be used when required by the Special Provisions.
- Reinforcing stirrup not required for roadbed offsets less than 1'-0".
- For roadbed surfaces offset greater than 1 1/2" and less than or equal to 3", no reinforcement required. For roadbed surfaces offset greater than 3" and less than or equal to 8", use two #4 Reinf at 3" above the lower roadbed surface. For roadbed surfaces offset greater than 8" and less than or equal to 12", use two #4 Reinf at 3" above the lower roadbed surface and two #4 Reinf at 8" above the lower roadbed surface. For roadbed surfaces offset greater than 12" and less than or equal to 36", use two #4 Reinf at 3" above the lower roadbed surface and two #4 Reinf at every 8" increment vertical spacing above the first two #4 Reinf.

STATE OF CALIFORNIA
DEPARTMENT OF TRANSPORTATION

CONCRETE BARRIER TYPE 60MS

NO SCALE

RSP A76G DATED APRIL 20, 2018 SUPERSEDES STANDARD PLAN A76G
DATED OCTOBER 30, 2015 - PAGE 43 OF THE STANDARD PLANS BOOK DATED 2015.

REVISED STANDARD PLAN RSP A76G

NOTES:

1. See Revised Standard Plan RSP A76G for Concrete Barrier Type 60MS and Type 60MSA.
2. Footing monolithic or doweled with 2-#8 x 8" @ 2'-0". The footing is
3. 10" concrete barrier footing extends 10' back from structure.
4. See Revised Standard Plan RSP A78I for transition to Thrie Beam Barrier.

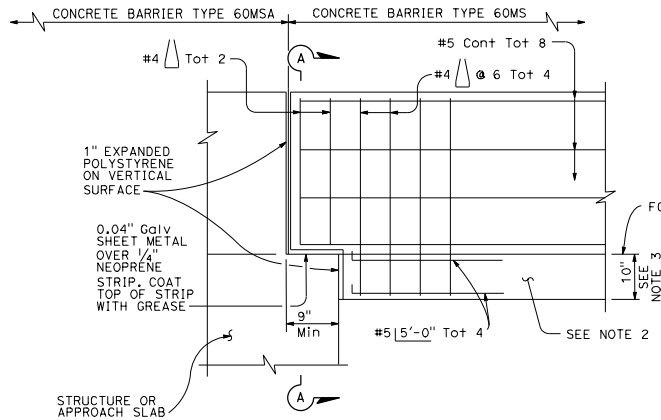

**CONCRETE BARRIER TYPE 60MS
CONNECTION TO STRUCTURE**

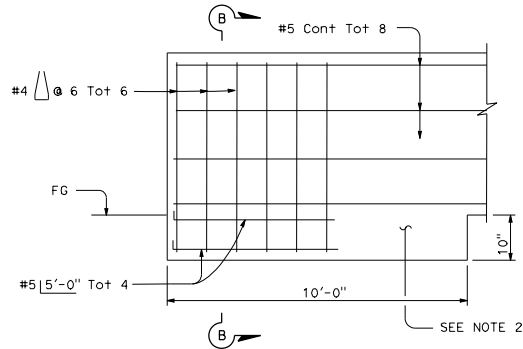

**CONCRETE BARRIER TYPE 60MS
END ANCHORAGE**

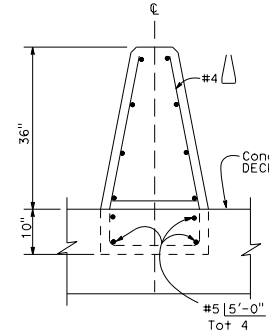

SECTION A-A

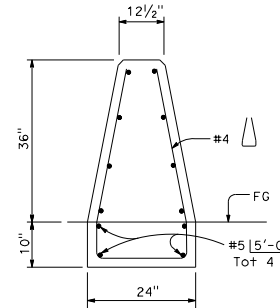

SECTION B-B

DIST	COUNTY	ROUTE	POST MILES TOTAL PROJECT	SHEET No.	TOTAL SHEETS
<i>Randell D. Hiatt</i> REGISTERED CIVIL ENGINEER					
April 20, 2018 PLANS APPROVAL DATE					
No. C50200 Exp. 6-30-19 CIVIL STATE OF CALIFORNIA					
<small>THE STATE OF CALIFORNIA OR ITS OFFICERS OR AGENTS SHALL NOT BE RESPONSIBLE FOR THE ACCURACY OR COMPLETENESS OF SCANNED COPIES OF THIS PLAN SHEET.</small>					

TO ACCOMPANY PLANS DATED _____

STATE OF CALIFORNIA
DEPARTMENT OF TRANSPORTATION

CONCRETE BARRIER TYPE 60MS

NO SCALE

RSP A76H DATED APRIL 20, 2018 SUPERSEDES STANDARD PLAN A76H
DATED OCTOBER 30, 2015 - PAGE 44 OF THE STANDARD PLANS BOOK DATED 2015.

REVISED STANDARD PLAN RSP A76H

DIST	COUNTY	ROUTE	POST MILES TOTAL PROJECT	SHEET NO.	TOTAL SHEETS

Randell D. Hiatt
REGISTERED CIVIL ENGINEER

April 20, 2018
PLANS APPROVAL DATE

REGISTERED PROFESSIONAL ENGINEER
Randell D. Hiatt
No. C50200
Exp. 6-30-19
CIVIL
STATE OF CALIFORNIA

THE STATE OF CALIFORNIA OR ITS OFFICERS OR AGENTS SHALL NOT BE RESPONSIBLE FOR THE ACCURACY OR COMPLETENESS OF SCANNED COPIES OF THIS PLAN SHEET.

TO ACCOMPANY PLANS DATED _____

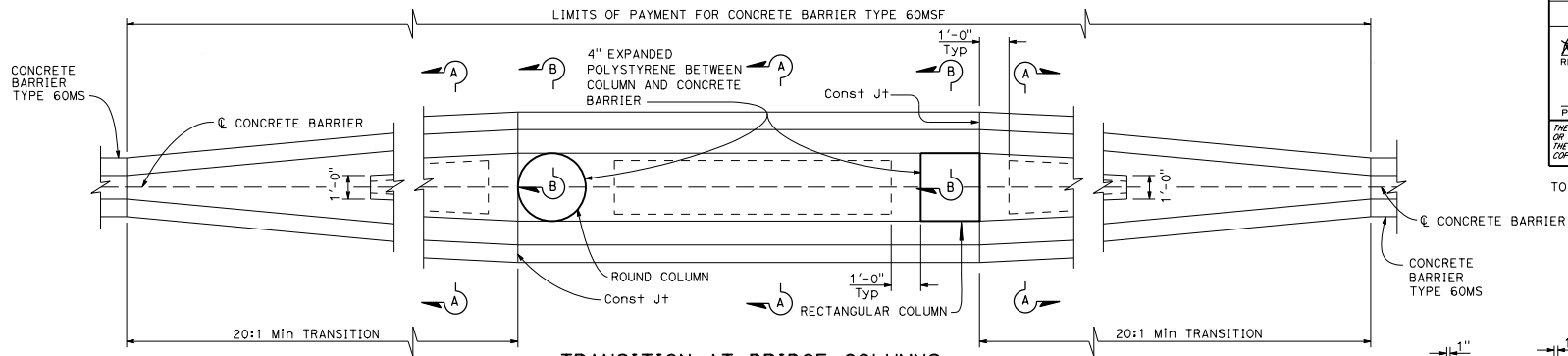

TRANSITION AT BRIDGE COLUMNS

Concrete Barrier Type 60MSF
See Note 7

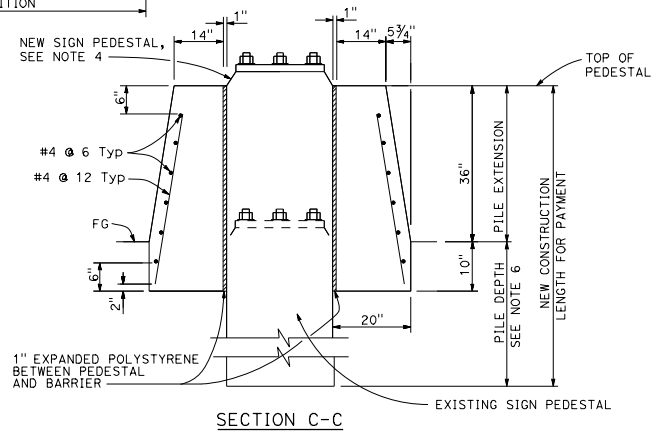
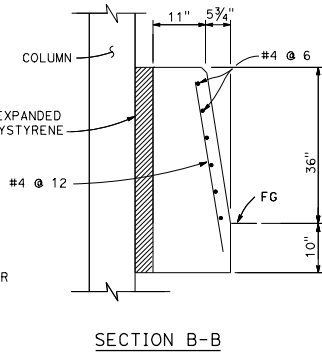
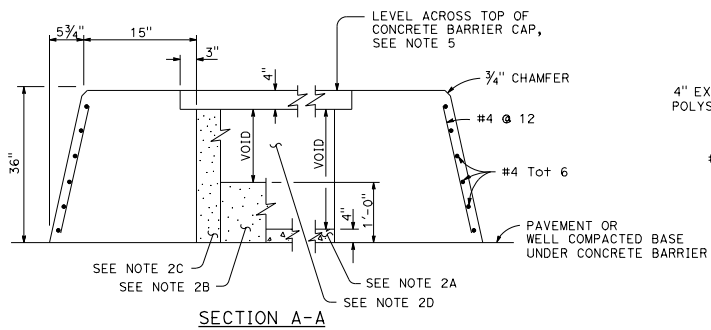

NOTES:

- See Revised Standard Plan RSP A76G for Concrete Barrier Type 60MS.
- Contractor options for fill between concrete barrier walls:
 - Place 4" PCC at base between concrete barrier walls.
 - Place 1'-0" of granular material at base between walls.
 - Place granular material from base to bottom of 4" cap.
 - Monolithic concrete with foam blockouts is not permitted.
- Reinforcing steel shall extend continuous through construction joints.
- See Overhead Sign plans for sign pedestal elevations on new construction.
- Adjust height of concrete barrier wall on low side of offset or super-elevated roadways to provide level grade across top of concrete barrier cap.
- See Overhead Signs Standard Plan Pile Foundation Tables.
- All locations with limited shoulder width available for barrier, see Revised Standard Plan RSP A76F for use of Concrete Barrier Type 60MGF.

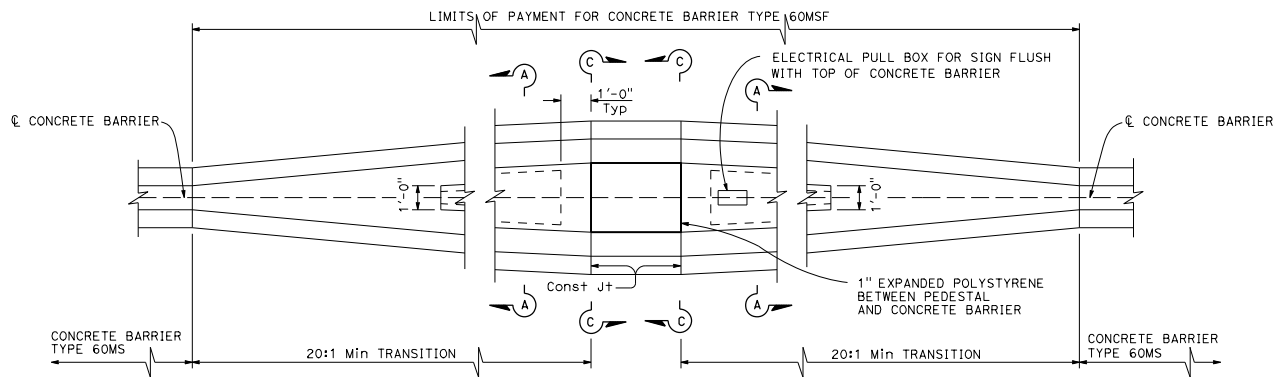

TRANSITION AT SIGN PEDESTAL

Concrete Barrier Type 60MSF
See Note 7

STATE OF CALIFORNIA
DEPARTMENT OF TRANSPORTATION
CONCRETE BARRIER TYPE 60MSF
NO SCALE

RSP A761 DATED APRIL 20, 2018 SUPERSEDES STANDARD PLAN A761
DATED OCTOBER 30, 2015 - PAGE 45 OF THE STANDARD PLANS BOOK DATED 2015.

REVISED STANDARD PLAN RSP A761

2015 REVISED STANDARD PLAN RSP A761

DIST	COUNTY	ROUTE	POST MILES TOTAL PROJECT	SHEET NO.	TOTAL SHEETS
<p><i>Randell D. Hiatt</i> REGISTERED CIVIL ENGINEER</p> <p>April 20, 2018 PLANS APPROVAL DATE</p> <p>No. C50200 Exp. 6-30-19 CIVIL STATE OF CALIFORNIA</p> <p>REGISTERED PROFESSIONAL ENGINEER</p> <p>THE STATE OF CALIFORNIA OR ITS OFFICERS OR AGENTS SHALL NOT BE RESPONSIBLE FOR THE ACCURACY OR COMPLETENESS OF SCANNED COPIES OF THIS PLAN SHEET.</p>					

TO ACCOMPANY PLANS DATED _____

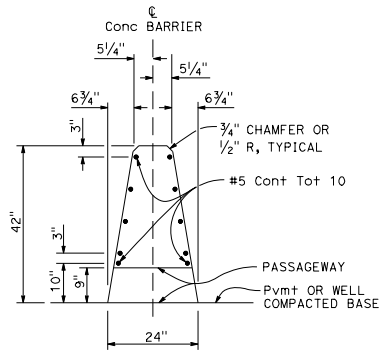

SECTION A-A
(Concrete Barrier Type 60M shown)

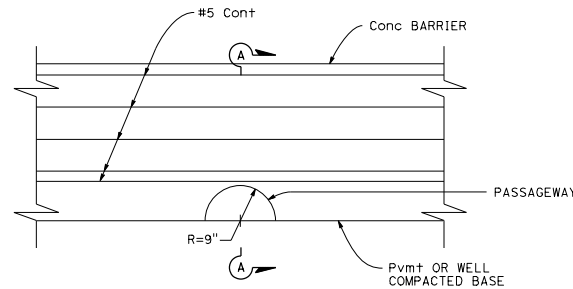

ELEVATION
See Notes 1 and 2

NOTES:

1. Type MS Passageway typically used for crossing of small size animals.
2. See Revised Standard Plan RSP A76A for typical details of Concrete Barrier Type 60M.

STATE OF CALIFORNIA
DEPARTMENT OF TRANSPORTATION
**CONCRETE BARRIER
WILDLIFE PASSAGEWAY
(TYPE MS)**

NO SCALE

RSP A76J DATED APRIL 20, 2018 SUPERSEDES STANDARD PLAN A76J
DATED OCTOBER 30, 2015 - PAGE 46 OF THE STANDARD PLANS BOOK DATED 2015.

REVISED STANDARD PLAN RSP A76J

2015 REVISED STANDARD PLAN RSP A76J

Dist	COUNTY	ROUTE	POST MILES TOTAL PROJECT	SHEET No.	TOTAL SHEETS

Randell D. Hiatt
REGISTERED CIVIL ENGINEER

April 20, 2018
PLANS APPROVAL DATE

No. C60200
Exp. 6-30-19
CIVIL
STATE OF CALIFORNIA

THE STATE OF CALIFORNIA OR ITS OFFICERS OR AGENTS SHALL NOT BE RESPONSIBLE FOR THE ACCURACY OR COMPLETENESS OF SCANNED COPIES OF THIS PLAN SHEET.

TO ACCOMPANY PLANS DATED _____

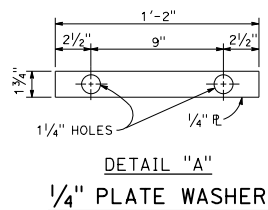
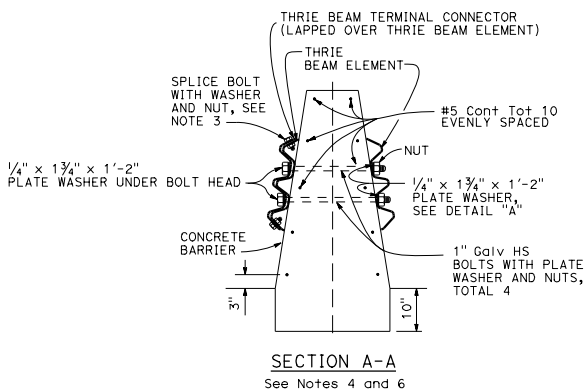
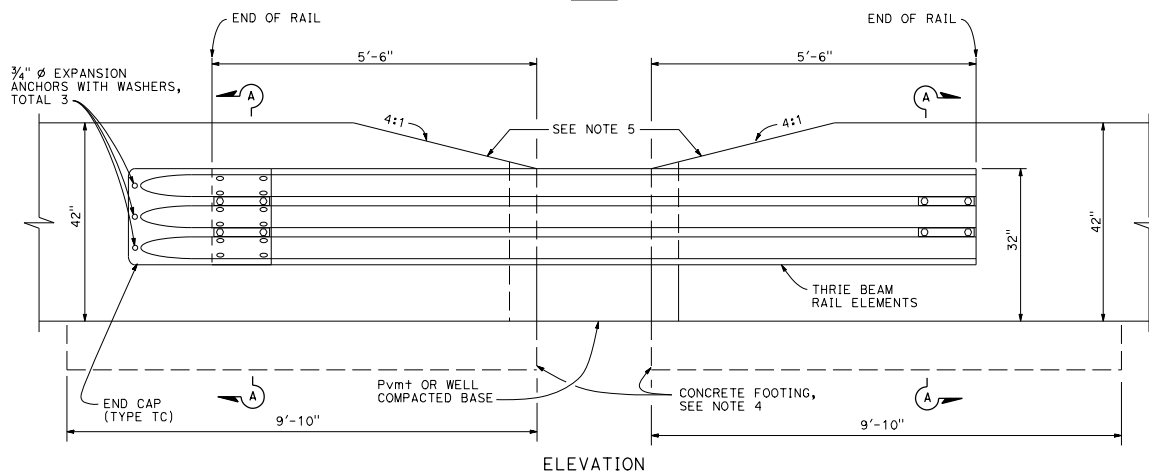
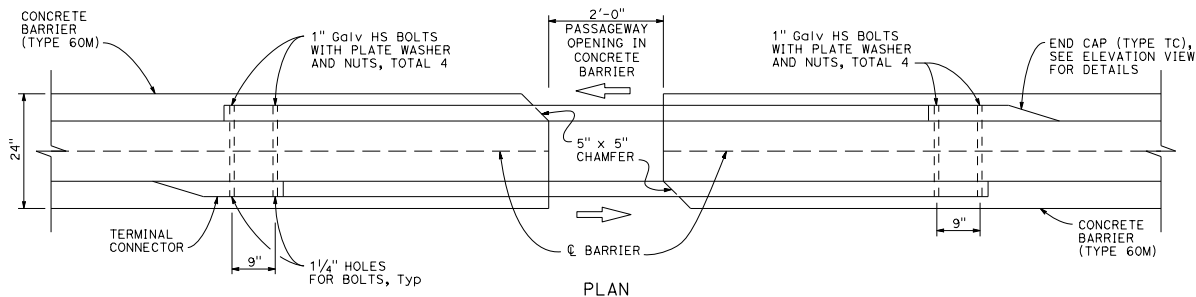

NOTES:

1. Type MM Passageway typically used for crossing of medium size animals.
2. For details of the thrie beam element and hardware, see the A78 series of the Standard Plans. For details of Concrete Barrier Type 60, see the A76 series of the Standard Plans.
3. The end cap, and the thrie beam element, may be spliced together prior to bolting the elements to the concrete barrier. All 8 splice bolts to connect the end cap to the rail element are not required. The 2 top and the 2 bottom splice bolts with washers and nuts shall be used.
4. Barrier end anchorage shall be constructed as shown in Section A-A of this plan or as shown on Standard Plan A76B.
5. Taper the top of the end of the concrete barrier at 4:1 to match the top elevation of the thrie beam rail element.
6. For details not shown, see Revised Standard Plan RSP A76A.

STATE OF CALIFORNIA
DEPARTMENT OF TRANSPORTATION

**CONCRETE BARRIER
WILDLIFE PASSAGEWAY
(TYPE MM)**

NO SCALE

RSP A76K DATED APRIL 20, 2018 SUPERSEDES STANDARD PLAN A76K
DATED OCTOBER 30, 2015 - PAGE 47 OF THE STANDARD PLANS BOOK DATED 2015.

REVISED STANDARD PLAN RSP A76K

2015 REVISED STANDARD PLAN RSP A76K

DIST	COUNTY	ROUTE	POST MILES TOTAL PROJECT	SHEET No.	TOTAL SHEETS
<i>Randell D. Hiatt</i> REGISTERED CIVIL ENGINEER					
April 20, 2018 PLANS APPROVAL DATE					
No. C50200 Exp. 6-30-19 CIVIL STATE OF CALIFORNIA					

TO ACCOMPANY PLANS DATED _____

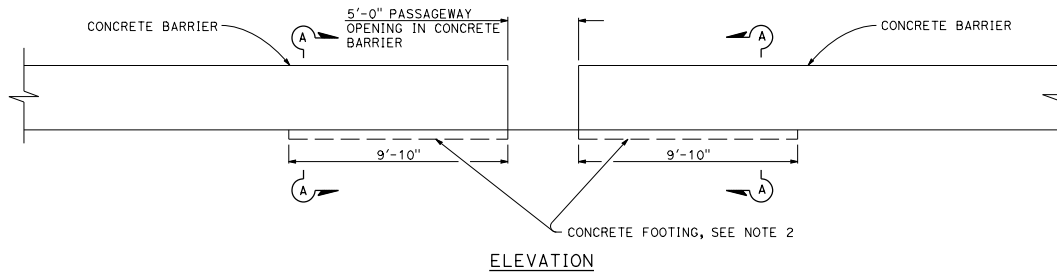
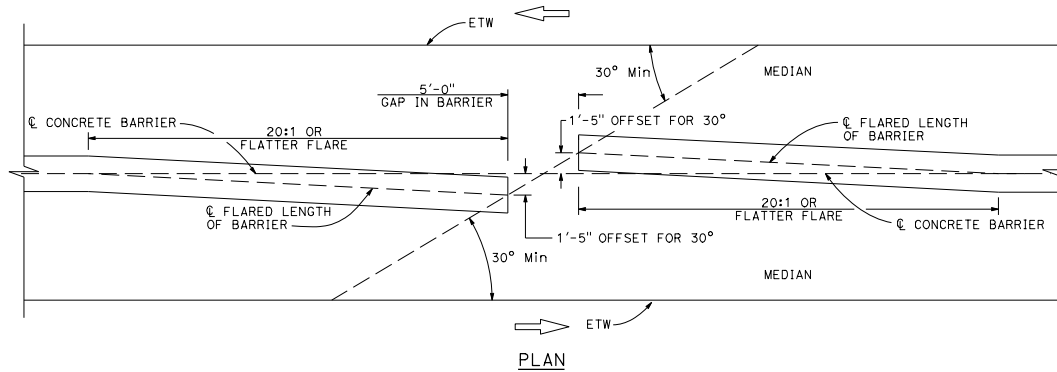

NOTES:

1. Type ML Passageway typically used for crossing of large size animals.
2. Barrier end anchorage shall be constructed as shown in Section A-A of this plan or as shown on Revised Standard Plan RSP A76B.

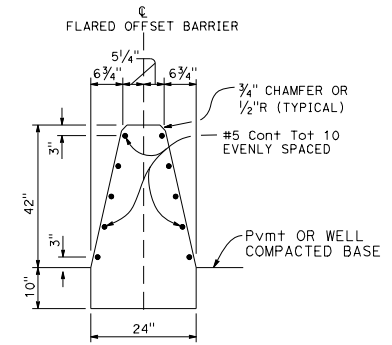

SECTION A-A
See Note 2

STATE OF CALIFORNIA
DEPARTMENT OF TRANSPORTATION
**CONCRETE BARRIER
WILDLIFE PASSAGEWAY
(TYPE ML)**
NO SCALE

RSP A76L DATED APRIL 20, 2018 SUPERSEDES STANDARD PLAN A76L
DATED OCTOBER 30, 2015 - PAGE 48 OF THE STANDARD PLANS BOOK DATED 2015.

REVISED STANDARD PLAN RSP A76L

2015 REVISED STANDARD PLAN RSP A76L

DIST	COUNTY	ROUTE	POST MILES TOTAL PROJECT	SHEET NO.	TOTAL SHEETS

Randell D. Hiatt
REGISTERED CIVIL ENGINEER

January 20, 2017
PLANS APPROVAL DATE

THE STATE OF CALIFORNIA OR ITS OFFICERS OR AGENTS SHALL NOT BE RESPONSIBLE FOR THE ACCURACY OR COMPLETENESS OF SCANNED COPIES OF THIS PLAN SHEET.

REGISTERED PROFESSIONAL ENGINEER
No. C50200
Exp. 6-30-17
CIVIL
STATE OF CALIFORNIA

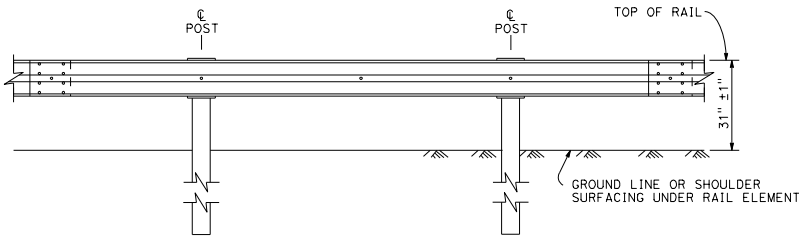
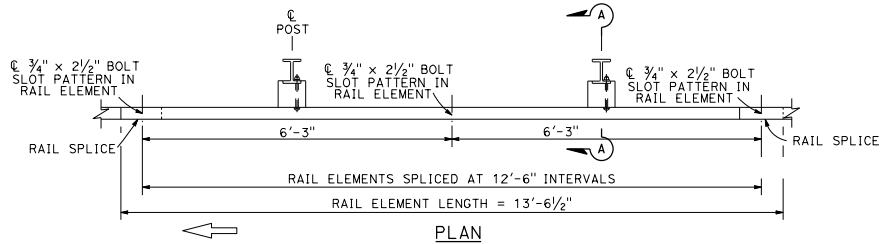

**MIDWEST GUARDRAIL SYSTEM WITH STEEL POSTS
AND NOTCHED WOOD OR NOTCHED RECYCLED PLASTIC BLOCKS**

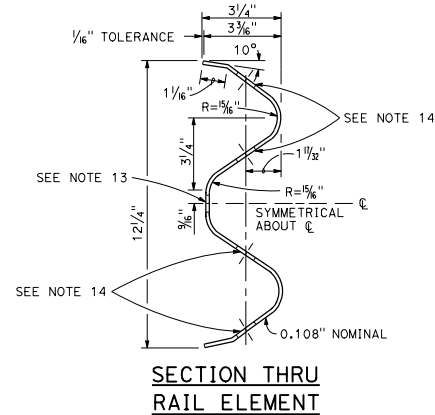

**SECTION THRU
RAIL ELEMENT**

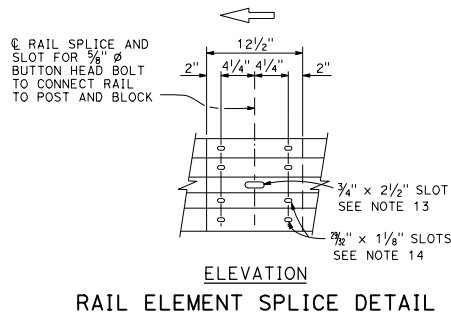

- Connect the overlapped end of the rail elements with $\frac{5}{8}$ " \times $1\frac{1}{8}$ " button head oval shoulder splice bolts inserted into the $\frac{3}{8}$ " \times $1\frac{1}{8}$ " slots and bolted together with $\frac{3}{8}$ " ϕ recessed hex nuts. Recess of hex nut points toward rail element. A total of 8 bolts and nuts are to be used at each rail splice connection.
- The ends of the rail elements are to be overlapped in the direction of traffic (see details).
- Where end cap is to be attached to the end of a rail element, a total of 4 of the above described splice bolts and nuts are to be used.

$\frac{5}{8}$ " ϕ BUTTON HEAD BOLT WITH HEX NUT. ATTACH RAIL ELEMENT TO WOOD BLOCK AND STEEL POST WITH BOLT ON TRAFFIC APPROACH SIDE OF POST WEB. NO WASHER ON RAIL FACE FOR BOLTED CONNECTION TO LINE POST

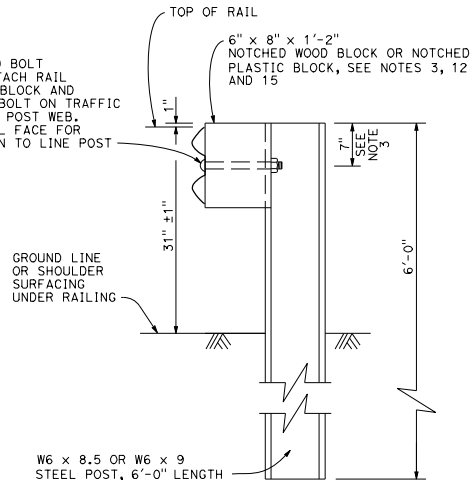

**SECTION A-A
TYPICAL STEEL LINE
POST INSTALLATION**

See Note 4

NOTES:

- For details of wood post installations, see Revised Standard Plan RSP A77L1.
- For details of standard hardware used to construct MGS, see Standard Plan A77M1.
- For details of steel posts and notched wood blocks used to construct MGS, see Revised Standard Plan RSP A77N2.
- For additional installation details, see Standard Plan A77N3.
- MGS post spacing to be 6'-3" center to center, except as otherwise noted.
- For MGS typical layouts, see the A77P, A77Q and A77R Series of Standard Plans.
- If railing is connected to terminal system end treatment, use 31" height terminal system end treatment.
- For MGS end anchor details, see Standard Plans A77S1 and A77T2.
- For details of MGS transition to bridge railing, see Standard Plan A77U4.
- For additional details of MGS connection to bridge railings, see Standard Plans A77U1, A77U2 and A77V1.
- For dike positioning and MGS delineation details, see Standard Plan A77N4.
- Notched face of block faces steel post.
- Slotted hole for bolted connection of rail element to block and post.
- Slotted holes for splice bolts to overlap ends of rail element.
- 6" \times 12" \times 1'-2" block must be used with 6" dike.

STATE OF CALIFORNIA
DEPARTMENT OF TRANSPORTATION

**MIDWEST GUARDRAIL SYSTEM
STANDARD RAILING SECTION
(STEEL POST WITH NOTCHED
WOOD OR NOTCHED
RECYCLED PLASTIC BLOCK)**

NO SCALE

RSP A77L2 DATED JANUARY 20, 2017 SUPERSEDES STANDARD PLAN A77L2
DATED OCTOBER 30, 2015 - PAGE 50 OF THE STANDARD PLANS BOOK DATED 2015.

REVISED STANDARD PLAN RSP A77L2

2015 REVISED STANDARD PLAN RSP A77L2

DIST	COUNTY	ROUTE	POST MILES TOTAL PROJECT	SHEET NO.	TOTAL SHEETS

Randell D. Hiatt
REGISTERED CIVIL ENGINEER

January 20, 2017
PLANS APPROVAL DATE

REGISTERED PROFESSIONAL ENGINEER
No. C50200
Exp. 6-30-17
CIVIL
STATE OF CALIFORNIA

THE STATE OF CALIFORNIA OR ITS OFFICERS OR AGENTS SHALL NOT BE RESPONSIBLE FOR THE ACCURACY OR COMPLETENESS OF SCANNED COPIES OF THIS PLAN SHEET.

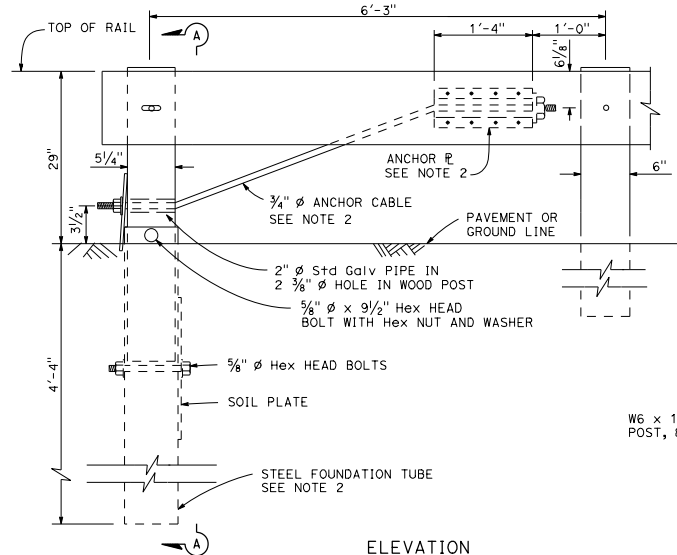

**ELEVATION
END ANCHOR
ASSEMBLY (TYPE SFT)**

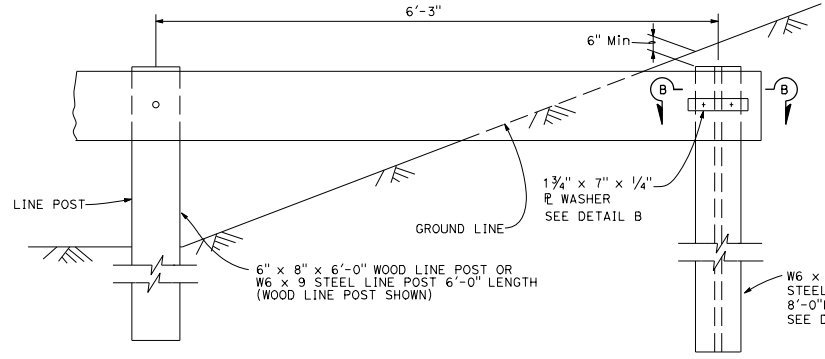

BURIED POST END ANCHOR

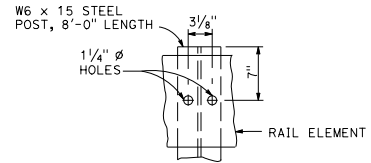

DETAIL A

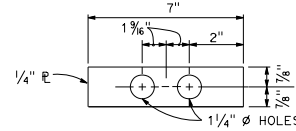

DETAIL B

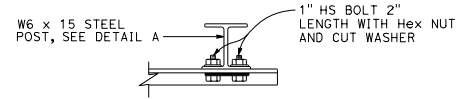

SECTION B-B

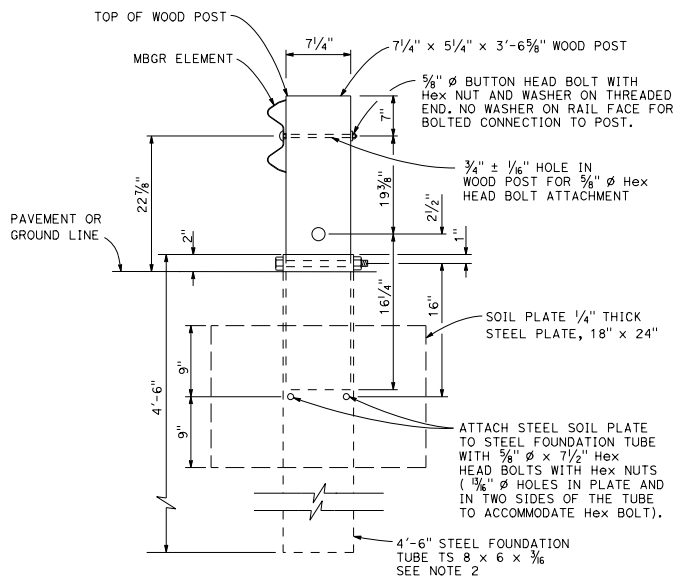

SECTION A-A

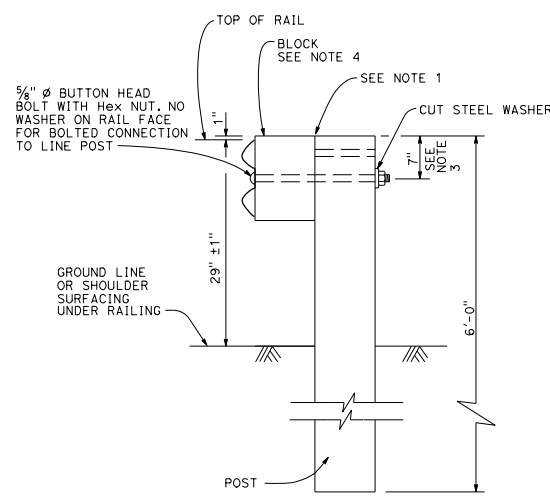

**TYPICAL LINE
POST INSTALLATION**

NOTES:

1. For wood post and wood block, toenail with 2-16d Galv nails in top of block. For steel post and notched wood or plastic block, notched face of block faces steel post.
2. A 6'-0" Length steel foundation tube, TS 8 x 6 x 3/8, without a soil plate, may be furnished and installed in place of the 4'-6" length steel foundation tube and soil plate shown. Minimum embedment of the 6'-0" length tube shall be 5'-9". A 5/8" diameter hex head bolt and nut shall be installed in the hole in the 6'-0" length tube to keep the wood post from dropping into the tube.
3. To connect railing to 27" terminal system end treatment, transition the top of railing height at a ratio of 120:1 to terminal system end treatment height plus one 12'-6" standard railing section at the transitioned height for a horizontal connection to the end treatment.
4. See Revised Standard Plans RSP A77N1 and RSP A77N2 for details.

STATE OF CALIFORNIA
DEPARTMENT OF TRANSPORTATION
**METAL BEAM GUARD RAILING
RECONSTRUCT INSTALLATION**

NO SCALE

RSP A77L3 DATED JANUARY 20, 2017 SUPERSEDES STANDARD PLAN A77L3
DATED OCTOBER 30, 2015 - PAGE 51 OF THE STANDARD PLANS BOOK DATED 2015.
REVISED STANDARD PLAN RSP A77L3

2015 REVISED STANDARD PLAN RSP A77L3

DIST	COUNTY	ROUTE	POST MILES TOTAL PROJECT	SHEET TOTAL NO. SHEETS
<i>Randell D. Hiatt</i> REGISTERED CIVIL ENGINEER				
January 20, 2017 PLANS APPROVAL DATE				
No. C50200 Exp. 6-30-17 CIVIL				
<small>THE STATE OF CALIFORNIA OR ITS OFFICERS OR AGENTS SHALL NOT BE RESPONSIBLE FOR THE ACCURACY OR COMPLETENESS OF SCANNED COPIES OF THIS PLAN SHEET.</small>				

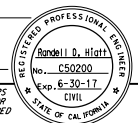

TO ACCOMPANY PLANS DATED _____

2015 REVISED STANDARD PLAN RSP A77N1

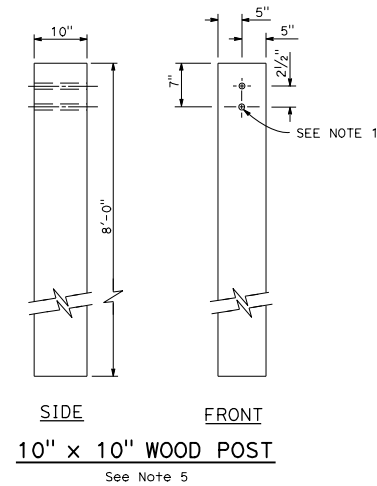
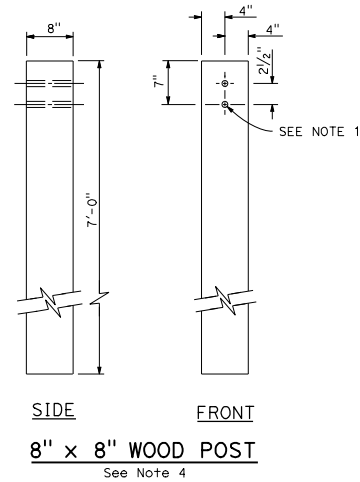
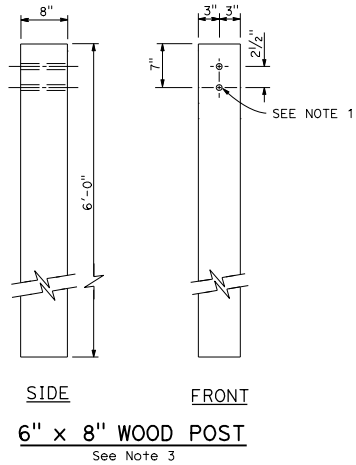

NOTES:

1. All holes in wood posts and blocks shall be 3/4" Dia ± 1/16".
2. Dimensions shown for wood post are nominal.
3. This post and block combination used for standard line post sections of MGS.
4. This post and 8" x 12" block combination used for line post sections of MGS on narrow roadways.
5. This post and 8" x 12" block combination is typically used where strengthened line post sections of MGS are warranted to shield fixed objects.
6. See Revised Standard Plan RSP A77L3 for use of 6" x 8" and 8" x 8" wood blocks.
7. To be used with 8" x 8" x 7'-0" wood post if installed with 6" height dike.
8. To be used with 6" x 8" x 6'-0" wood post if installed with 6" height dike.

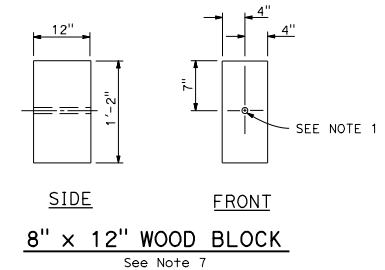
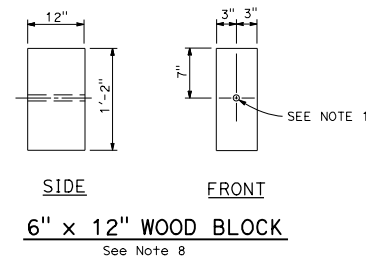
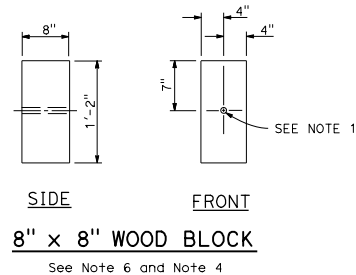
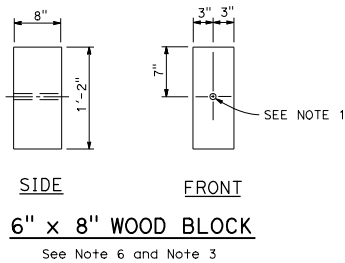

STATE OF CALIFORNIA
DEPARTMENT OF TRANSPORTATION

**MIDWEST GUARDRAIL SYSTEM
WOOD POST AND
WOOD BLOCK DETAILS**

NO SCALE

RSP A77N1 DATED JANUARY 20, 2017 SUPERSEDES STANDARD PLAN A77N1
DATED OCTOBER 30, 2015 - PAGE 53 OF THE STANDARD PLANS BOOK DATED 2015.

REVISED STANDARD PLAN RSP A77N1

DIST	COUNTY	ROUTE	POST MILES TOTAL PROJECT	SHEET TOTAL SHEETS

Randell D. Hiatt
REGISTERED CIVIL ENGINEER

January 20, 2017
PLANS APPROVAL DATE

REGISTERED PROFESSIONAL ENGINEER
No. C50200
Exp. 6-30-17
CIVIL
STATE OF CALIFORNIA

THE STATE OF CALIFORNIA OR ITS OFFICERS OR AGENTS SHALL NOT BE RESPONSIBLE FOR THE ACCURACY OR COMPLETENESS OF SCANNED COPIES OF THIS PLAN SHEET.

TO ACCOMPANY PLANS DATED _____

NOTES:

- All holes in steel post shall be $\frac{1}{8}$ " Dia maximum.
- Dimensions shown for wood block are nominal.
- Notched face of block faces steel post.
- 6'-0" length posts to be used for typical roadway installation. See Standard Plan A77N3.
- See Revised Standard Plan RSP A77L3 for use of 6" x 8" and 8" x 8" notched wood blocks.
- This post and 8" x 12" block combination to be used for line post sections of MGS on narrow roadways and where strengthened line post sections of MGS are warranted to shield fixed objects.
- 6" x 12" notched wood block and 8" x 12" notched wood block must be used with 6" dike.

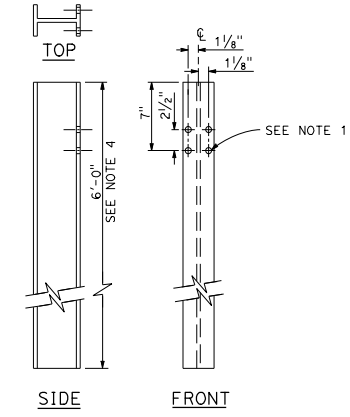

**W6 x 9 OR W6 x 8.5
STEEL POST**
See Note 4

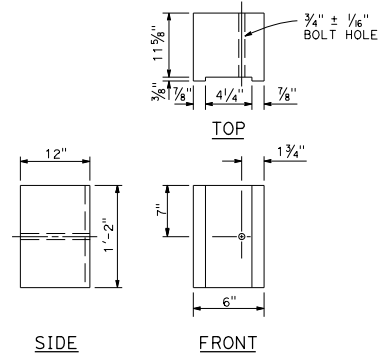

**6" x 12"
NOTCHED WOOD BLOCK**
See Notes 2, 3 and 7

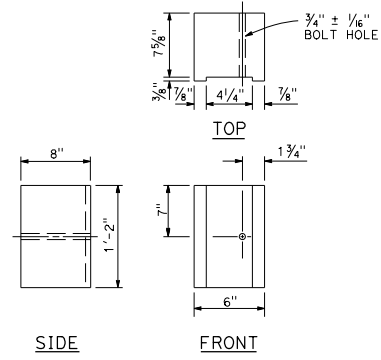

**6" x 8"
NOTCHED WOOD BLOCK**
Only for use with metal beam guard railing. See Note 5

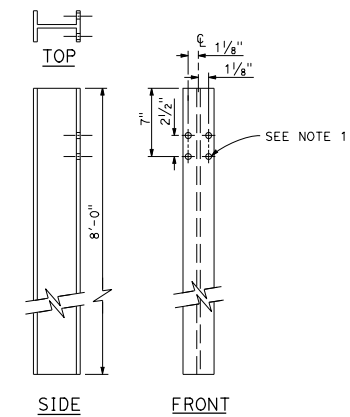

**W6 x 9 OR W6 x 8.5
STEEL POST**
See Note 6

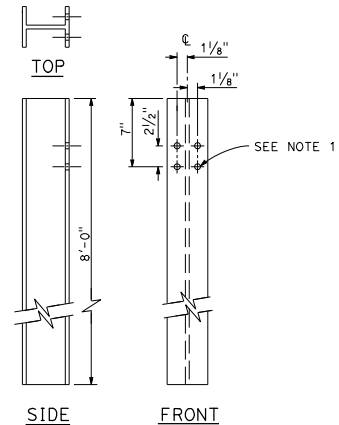

**W6 x 15
STEEL POST**

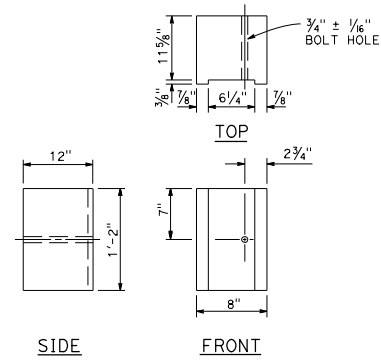

**8" x 12"
NOTCHED WOOD BLOCK**
See Notes 2, 3 and 7

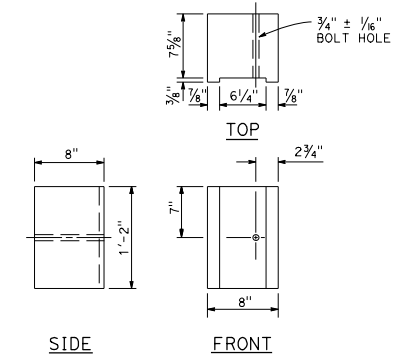

**8" x 8"
NOTCHED WOOD BLOCK**
Only for use with metal beam guard railing. See Note 5

STATE OF CALIFORNIA
DEPARTMENT OF TRANSPORTATION
**MIDWEST GUARDRAIL SYSTEM
STEEL POST AND
NOTCHED WOOD BLOCK DETAILS**
NO SCALE

RSP A77N2 DATED JANUARY 20, 2017 SUPERSEDES STANDARD PLAN A77N2
DATED OCTOBER 30, 2015 - PAGE 54 OF THE STANDARD PLANS BOOK DATED 2015.

REVISED STANDARD PLAN RSP A77N2

2015 REVISED STANDARD PLAN RSP A77N2

DIST	COUNTY	ROUTE	POST MILES TOTAL PROJECT	SHEET TOTAL SHEETS

Randell D. Hiatt
REGISTERED CIVIL ENGINEER

January 20, 2017
PLANS APPROVAL DATE

REGISTERED PROFESSIONAL ENGINEER
Randell D. Hiatt
No. C50200
Exp. 6-30-17
CIVIL
STATE OF CALIFORNIA

THE STATE OF CALIFORNIA OR ITS OFFICERS OR AGENTS SHALL NOT BE RESPONSIBLE FOR THE ACCURACY OR COMPLETENESS OF SCANNED COPIES OF THIS PLAN SHEET.

TO ACCOMPANY PLANS DATED _____

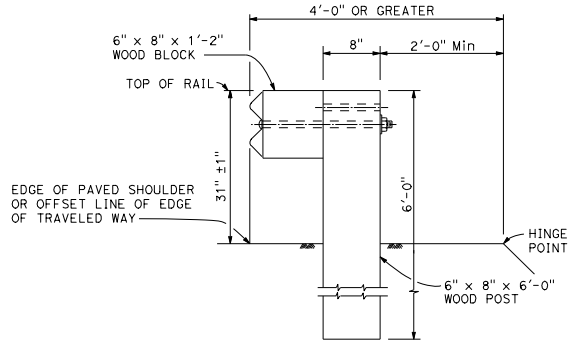

DETAIL A
TYPICAL ROADWAY
INSTALLATION
See Note 1

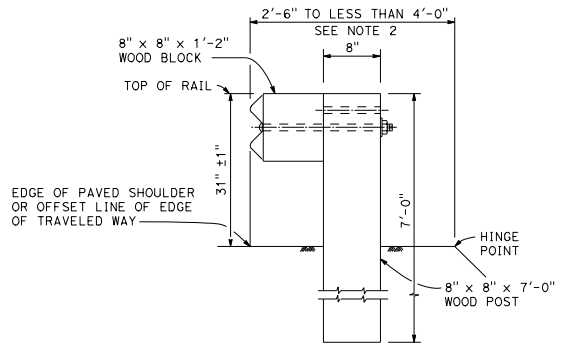

DETAIL B
NARROW ROADWAY
INSTALLATION
See Note 1

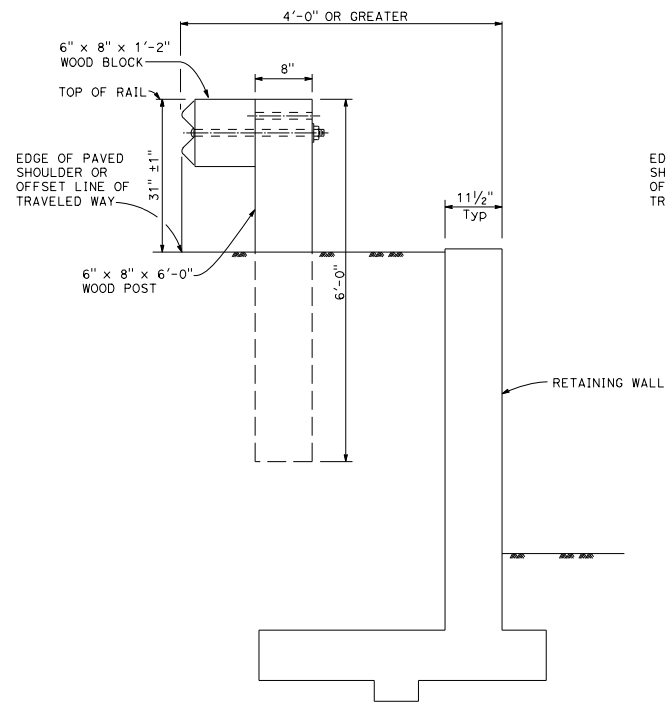

DETAIL C

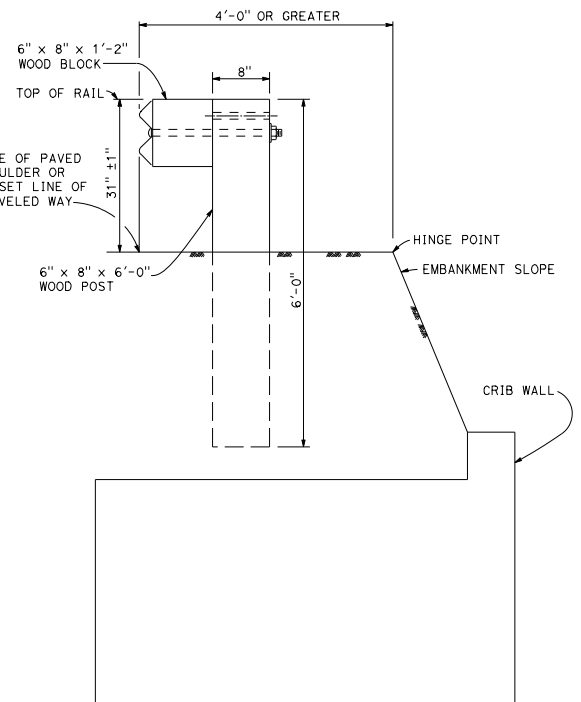

DETAIL D

INSTALLATION AT EARTH RETAINING WALLS

NOTES:

1. These installation details also applicable to steel line post installations. For Detail A, C, and D, where steel line post installations are constructed, W6 x 8.5 or W6 x 9 steel post, 6'-0" in length, with 6" x 8" x 1'-2" notched wood blocks or notched recycled plastic blocks are to be used in place of the size of wood post and wood block shown. For Detail B, where steel line post installations are constructed, W6 x 8.5 or W6 x 9 steel post, 8'-0" in length, with 8" x 8" x 1'-2" notched wood blocks or notched recycled plastic blocks are to be used in place of the size of wood post and wood block shown. For additional installation details, see Revised Standard Plans RSP A77L1 and RSP A77L2.
2. Where the distance between the face of the rail and the hinge point is less than 2'-6", see the Project Plans for special details.
3. For dike positioning with MGS installations, see Standard Plan A77N4.

STATE OF CALIFORNIA
DEPARTMENT OF TRANSPORTATION

MIDWEST GUARDRAIL SYSTEM
TYPICAL LINE POST
EMBEDMENT AND
HINGE POINT OFFSET DETAILS
NO SCALE

RSP A77N3 DATED JANUARY 20, 2017 SUPERSEDES STANDARD PLAN A77N3
DATED OCTOBER 30, 2015 - PAGE 55 OF THE STANDARD PLANS BOOK DATED 2015.

REVISED STANDARD PLAN RSP A77N3

2015 REVISED STANDARD PLAN RSP A77N3

Dist	COUNTY	ROUTE	POST MILES TOTAL PROJECT	SHEET TOTAL NO. SHEETS
<i>Chi H. Wong</i> REGISTERED CIVIL ENGINEER				
April 20, 2018 PLANS APPROVAL DATE				
THE STATE OF CALIFORNIA OR ITS OFFICERS OR AGENTS SHALL NOT BE RESPONSIBLE FOR THE ACCURACY OR COMPLETENESS OF SCANNED COPIES OF THIS PLAN SHEET.				

TO ACCOMPANY PLANS DATED _____

NOTES:

1. Where the distance between back of post and hinge point is less than 42", construct vegetation control to 6" from hinge point while maintaining the 8" block-out at back of post.
2. Where paved shoulder is constructed within 36" in front of the post, construct vegetation control to the edge of paved shoulder.
3. For wood post sizes, see Revised Standard Plan RSP A77N1.
4. For steel post sizes, see Revised Standard Plan RSP A77N2.
5. For details not shown, see Revised Standard Plans RSP A77L1 and RSP A77L2.
6. Where vegetation control is adjacent to a dike on a cut slope, construct vegetation control flush with the top edge of dike.
7. Vegetation control must slope to drain water.
8. Concrete over block-out material depth, construct 3/8" Min to 5/8" Max.
9. This plan for vegetation control installation only.

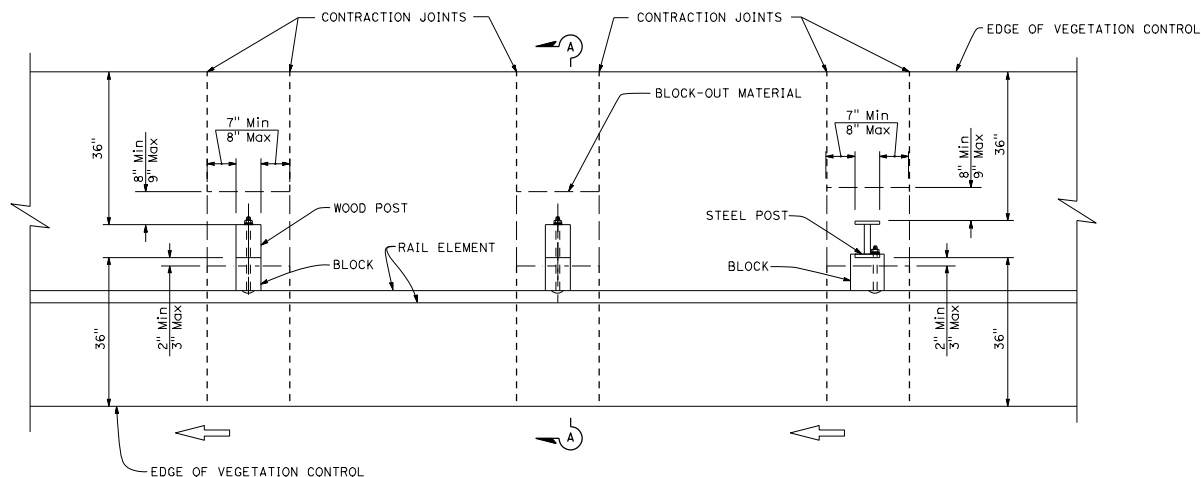

PLAN

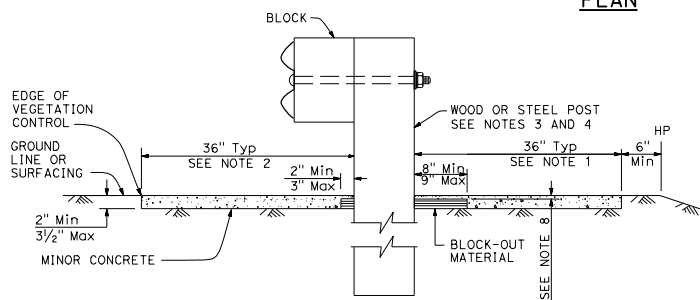

SECTION A-A

Without Existing Dike

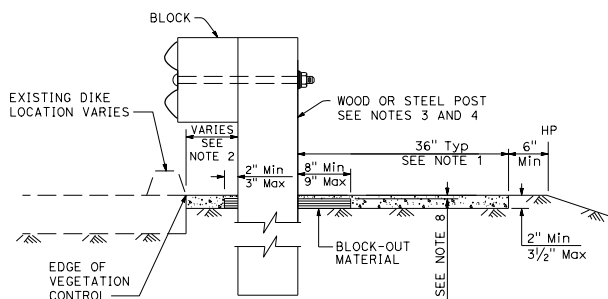

SECTION A-A

With Existing Dike

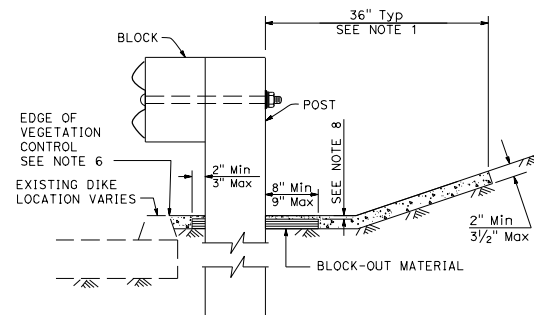

SECTION A-A

With Existing Dike
on cut slope

STATE OF CALIFORNIA
DEPARTMENT OF TRANSPORTATION

**MINOR CONCRETE VEGETATION CONTROL
GUARDRAIL SYSTEM**

NO SCALE

RSP A77N5 DATED APRIL 20, 2018 SUPERSEDES RSP A77N5 DATED JULY 21, 2017 AND STANDARD PLAN A77N5 DATED OCTOBER 30, 2015 - PAGE 57 OF THE STANDARD PLANS BOOK DATED 2015.

REVISED STANDARD PLAN RSP A77N5

2015 REVISED STANDARD PLAN RSP A77N5

DIST	COUNTY	ROUTE	POST MILES TOTAL PROJECT	SHEET TOTAL SHEETS
<i>Chi H. Wong</i> REGISTERED CIVIL ENGINEER				
April 20, 2018 PLANS APPROVAL DATE				
No. C054738 Exp. 12-31-19				
THE STATE OF CALIFORNIA OR ITS OFFICERS OR AGENTS SHALL NOT BE RESPONSIBLE FOR THE ACCURACY OR COMPLETENESS OF SCANNED COPIES OF THIS PLAN SHEET.				

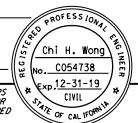

TO ACCOMPANY PLANS DATED _____

NOTES:

1. Use the details on this sheet when the length from the back of post to the hinge point is less than 18". Use the details on Revised Standard Plan RSP A77N5 when the length from the back of the post to the hinge point is greater than 18".
2. Construct vegetation control flush with the back edge of post.
3. Where paved shoulder is constructed within 36" in front of the post, construct vegetation control to the edge of paved shoulder.
4. For wood post sizes, see Revised Standard Plan RSP A77N1.
5. For steel post sizes, see Revised Standard Plan RSP A77N2.
6. For details not shown, see Revised Standard Plans RSP A77L1 and RSP A77L2.
7. Vegetation control must slope to drain water.
8. Concrete over block-out material depth, construct 3/8" Min to 5/8" Max.
9. This plan for vegetation control installation only.

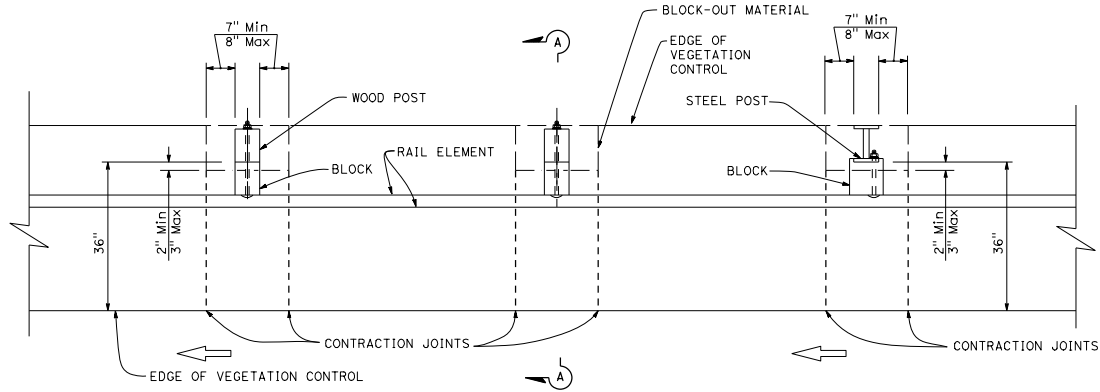

PLAN

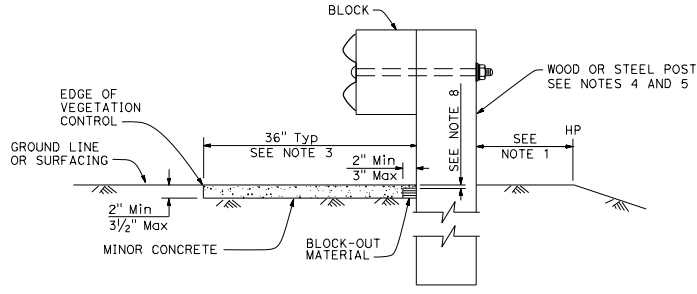

SECTION A-A

Without Existing Dike

STATE OF CALIFORNIA
DEPARTMENT OF TRANSPORTATION

**MINOR CONCRETE VEGETATION CONTROL
GUARDRAIL SYSTEM
NARROW VEGETATION CONTROL INSTALLATION**

NO SCALE
RSP A77N5A DATED APRIL 20, 2018 SUPERSEDES RSP A77N5A
DATED JULY 21, 2017 THAT SUPPLEMENTS THE STANDARD PLANS BOOK DATED 2015.

REVISED STANDARD PLAN RSP A77N5A

2015 REVISED STANDARD PLAN RSP A77N5A

DIST	COUNTY	ROUTE	POST MILES TOTAL PROJECT	SHEET TOTAL SHEETS
<i>Chi H. Wong</i> REGISTERED CIVIL ENGINEER				
April 20, 2018 PLANS APPROVAL DATE				
THE STATE OF CALIFORNIA OR ITS OFFICERS OR AGENTS SHALL NOT BE RESPONSIBLE FOR THE ACCURACY OR COMPLETENESS OF SCANNED COPIES OF THIS PLAN SHEET.				

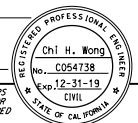

TO ACCOMPANY PLANS DATED _____

NOTES:

1. See Revised Standard Plan RSP A77N5 for additional vegetation control details.
2. Where the distance between back of post and hinge point is less than 42", construct vegetation control to 6" from hinge point while maintaining the 8" block-out at back of post.
3. Vegetation control must slope to drain water.
4. This plan for vegetation control installation only.

2015 REVISED STANDARD PLAN RSP A77N6

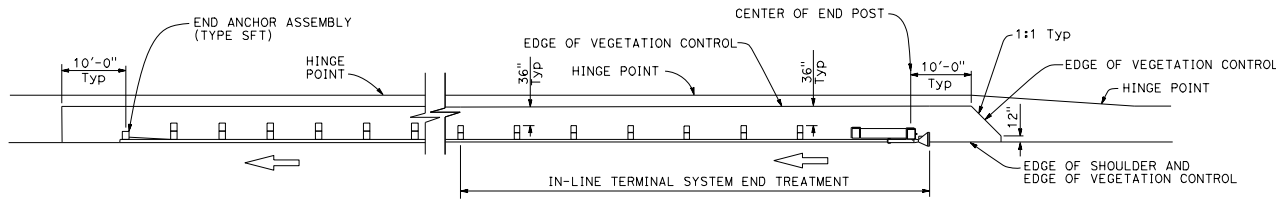

PLAN

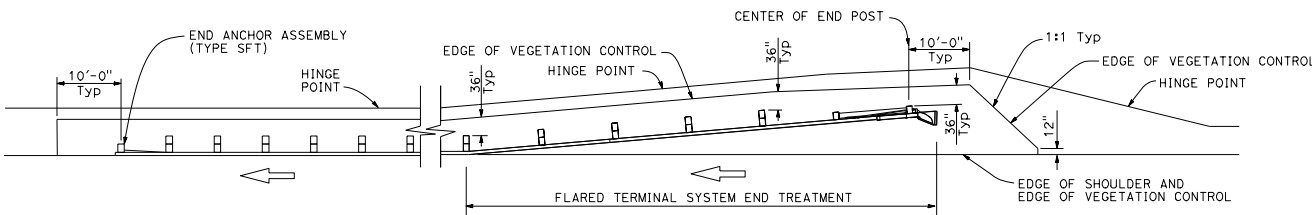

PLAN

STATE OF CALIFORNIA
DEPARTMENT OF TRANSPORTATION

**MINOR CONCRETE VEGETATION CONTROL
GUARDRAIL SYSTEM
FOR TERMINAL SYSTEM END TREATMENTS**

NO SCALE

RSP A77N6 DATED APRIL 20, 2018 SUPERSEDES RSP A77N6
DATED JULY 21, 2017 AND RSP A77N6 DATED JANUARY 20, 2017 AND STANDARD PLAN A77N6
DATED OCTOBER 30, 2015 - PAGE 58 OF THE STANDARD PLANS BOOK DATED 2015.

REVISED STANDARD PLAN RSP A77N6

DIST	COUNTY	ROUTE	POST MILES TOTAL PROJECT	SHEET NO.	TOTAL SHEETS

Chi H. Wong
 REGISTERED CIVIL ENGINEER
 No. C054738
 Exp. 12-31-19
 CIVIL
 STATE OF CALIFORNIA

APRIL 20, 2018
 PLANS APPROVAL DATE
 THE STATE OF CALIFORNIA OR ITS OFFICERS OR AGENTS SHALL NOT BE RESPONSIBLE FOR THE ACCURACY OR COMPLETENESS OF SCANNED COPIES OF THIS PLAN SHEET.

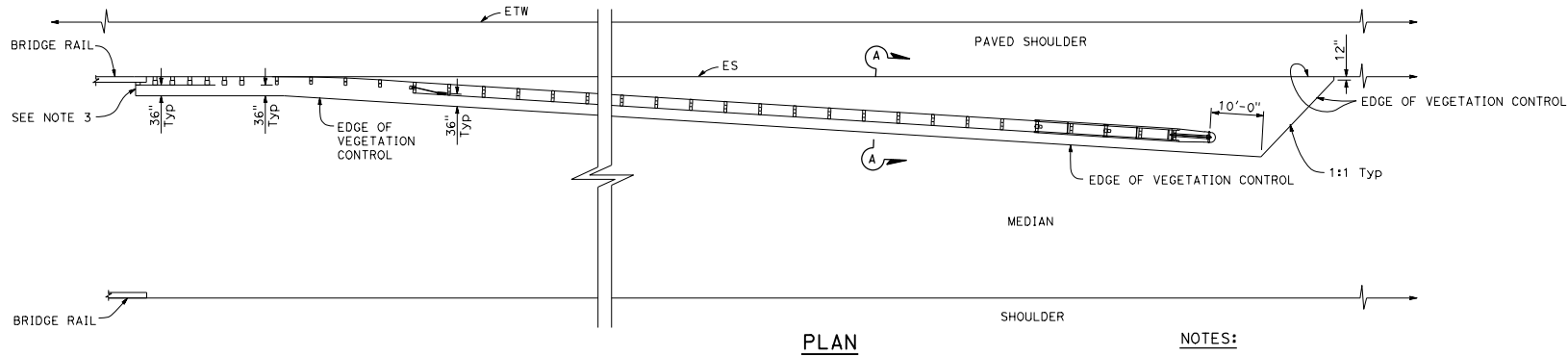
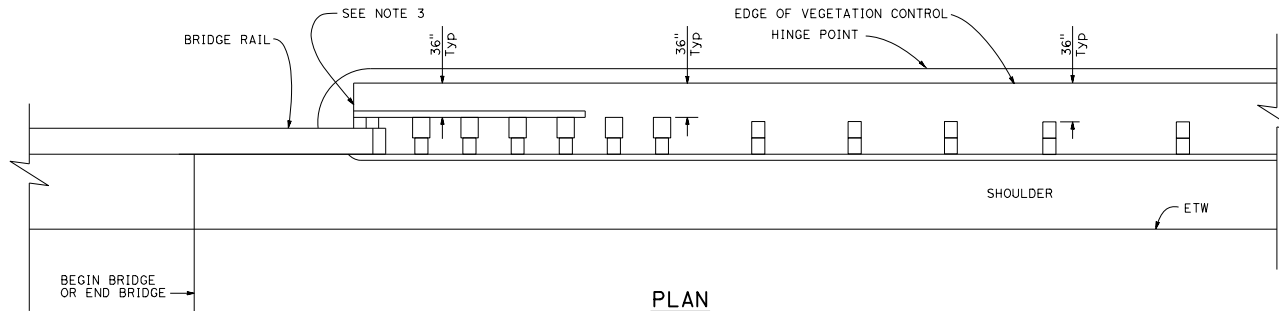

NOTES:

1. See Revised Standard Plan RSP A77N5 for additional vegetation control details.
2. Where the distance between back of post and hinge point is less than 42", construct vegetation control to 6" from hinge point while maintaining the 8" block-out at back of post.
3. End vegetation control at end of backside rail element.
4. Vegetation control must slope to drain water.
5. Concrete over block-out material depth, construct 3/8" Min to 5/8" Max.
6. This plan for vegetation control installation only.

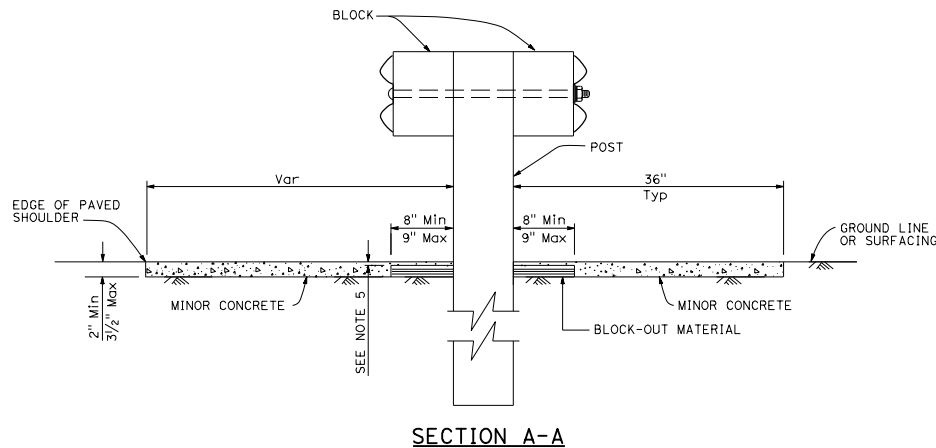

STATE OF CALIFORNIA
 DEPARTMENT OF TRANSPORTATION
**MINOR CONCRETE VEGETATION CONTROL
 GUARDRAIL SYSTEM
 AT STRUCTURE APPROACH**
 NO SCALE

RSP A77N7 DATED APRIL 20, 2018 SUPERSEDES RSP A77N7
 DATED JULY 21, 2017 AND STANDARD PLAN A77N7
 DATED OCTOBER 30, 2015 - PAGE 59 OF THE STANDARD PLANS BOOK DATED 2015.

REVISED STANDARD PLAN RSP A77N7

2015 REVISED STANDARD PLAN RSP A77N7

DIST	COUNTY	ROUTE	POST MILES TOTAL PROJECT	SHEET TOTAL NO. SHEETS
<i>Chi H. Wong</i> REGISTERED CIVIL ENGINEER				
April 20, 2018 PLANS APPROVAL DATE				
No. C054738 Exp. 12-31-19 CIVIL				
<small>THE STATE OF CALIFORNIA OR ITS OFFICERS OR AGENTS SHALL NOT BE RESPONSIBLE FOR THE ACCURACY OR COMPLETENESS OF SCANNED COPIES OF THIS PLAN SHEET.</small>				

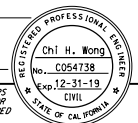

TO ACCOMPANY PLANS DATED _____

NOTES:

1. See Revised Standard Plan RSP A77N5 for additional vegetation control details.
2. Where paved shoulder is constructed within 36" in front of the post, construct vegetation control to the edge of paved shoulder.
3. Vegetation control must slope to drain water.
4. This plan for vegetation control installation only.

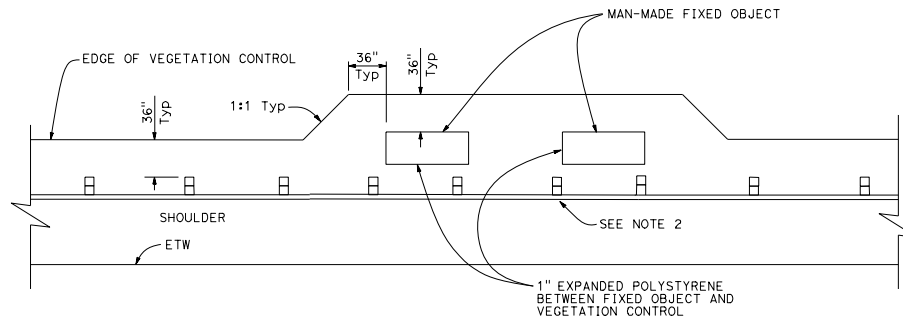

PLAN
Fixed object(s) on shoulder

2015 REVISED STANDARD PLAN RSP A77N8

STATE OF CALIFORNIA
DEPARTMENT OF TRANSPORTATION
**MINOR CONCRETE VEGETATION CONTROL
GUARDRAIL SYSTEM
AT FIXED OBJECT**
NO SCALE

RSP A77N8 DATED APRIL 20, 2018 SUPERSEDES RSP A77N8 DATED JULY 21, 2017 AND
STANDARD PLAN A77N8 DATED OCTOBER 30, 2015 - PAGE 60 OF THE STANDARD PLANS BOOK DATED 2015.

REVISED STANDARD PLAN RSP A77N8

Dist	COUNTY	ROUTE	POST MILES TOTAL PROJECT	SHEET NO.	TOTAL SHEETS

Chi H. Wong
 REGISTERED CIVIL ENGINEER
 No. C054738
 Exp. 12-31-19
 CIVIL
 STATE OF CALIFORNIA

April 20, 2018
 PLANS APPROVAL DATE
 THE STATE OF CALIFORNIA OR ITS OFFICERS
 OR AGENTS SHALL NOT BE RESPONSIBLE FOR
 THE ACCURACY OR COMPLETENESS OF SCANNED
 COPIES OF THIS PLAN SHEET.

TO ACCOMPANY PLANS DATED _____

NOTES:

1. See Revised Standard Plan RSP A77N5 for additional vegetation control details.
2. Where paved shoulder is constructed within 36" in front of the post, construct vegetation control to the edge of paved shoulder.
3. Vegetation control must slope to drain water.
4. Concrete over block-out material depth, construct $\frac{3}{8}$ " Min to $\frac{5}{8}$ " Max.
5. This plan for vegetation control installation only.

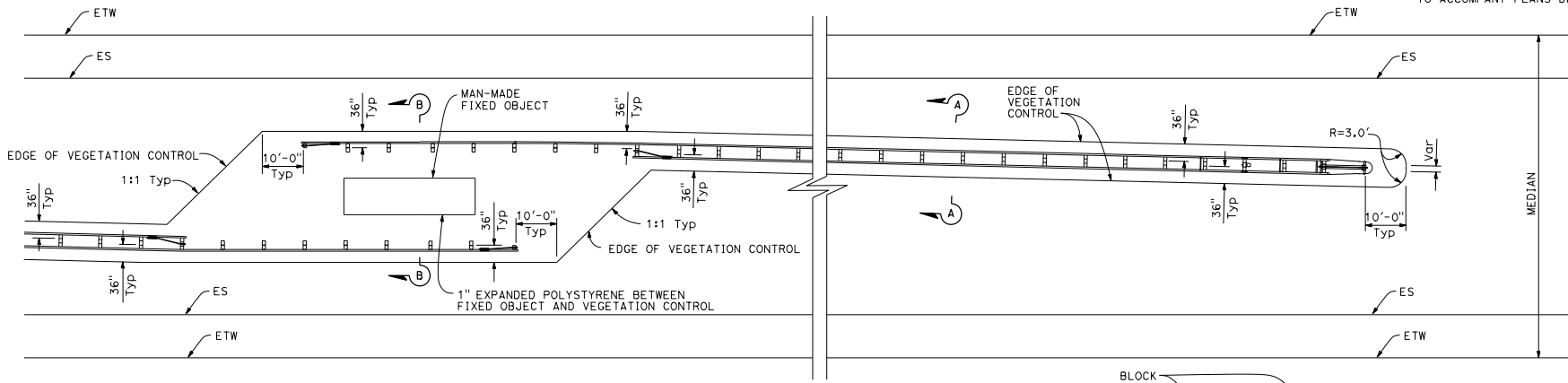

PLAN

Fixed object(s) in median

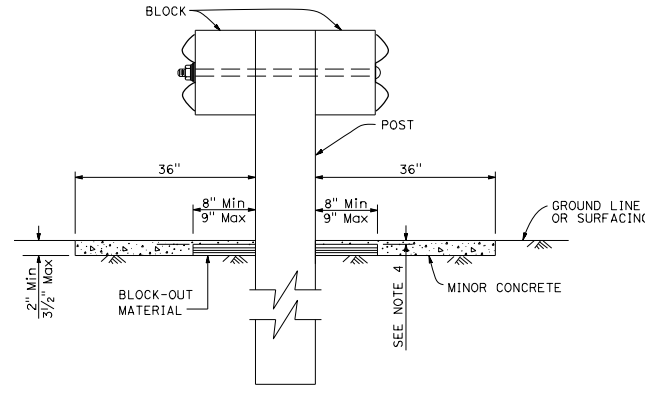

SECTION A-A

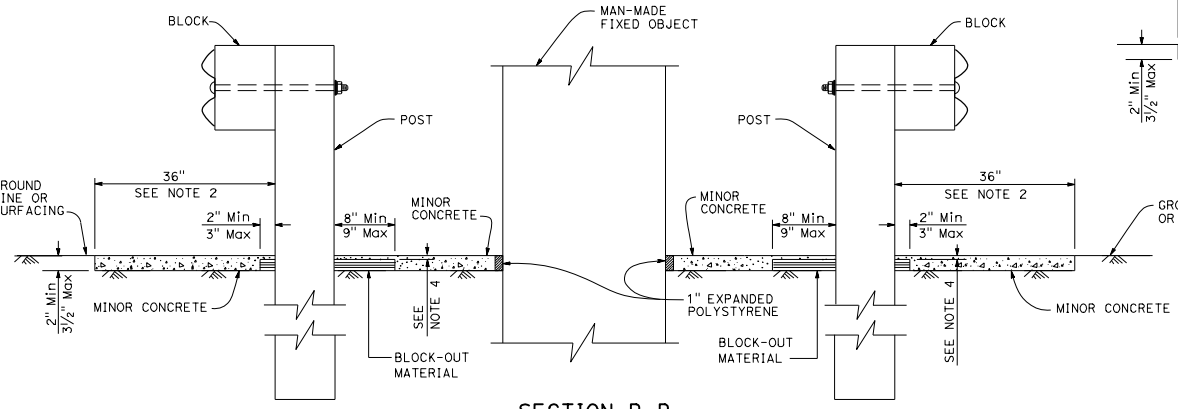

SECTION B-B

STATE OF CALIFORNIA
 DEPARTMENT OF TRANSPORTATION
**MINOR CONCRETE VEGETATION CONTROL
 GUARDRAIL SYSTEM
 AT FIXED OBJECT**

NO SCALE

RSP A77N9 DATED APRIL 20, 2018 SUPERSEDES RSP A77N9 DATED JULY 21, 2017 AND
STANDARD PLAN A77N9 DATED OCTOBER 30, 2015 - PAGE 61 OF THE STANDARD PLANS BOOK DATED 2015.

REVISED STANDARD PLAN RSP A77N9

2015 REVISED STANDARD PLAN RSP A77N9

NOTES:

1. See Revised Standard Plan RSP A77N5 for additional vegetation control details.
2. Where paved shoulder is constructed within 36" in front of the post, construct vegetation control to the edge of paved shoulder.
3. Vegetation control must slope to drain water.
4. Concrete over block-out material depth, construct $\frac{3}{8}$ " Min to $\frac{5}{8}$ " Max.
5. This plan for vegetation control installation only.

DIST	COUNTY	ROUTE	POST MILES TOTAL PROJECT	SHEET TOTAL SHEETS

Chi H. Wong
REGISTERED CIVIL ENGINEER

April 20, 2018
PLANS APPROVAL DATE

Chi H. Wong
No. C054738
Exp. 12-31-19
REGISTERED PROFESSIONAL ENGINEER
CIVIL
STATE OF CALIFORNIA

THE STATE OF CALIFORNIA OR ITS OFFICERS OR AGENTS SHALL NOT BE RESPONSIBLE FOR THE ACCURACY OR COMPLETENESS OF SCANNED COPIES OF THIS PLAN SHEET.

TO ACCOMPANY PLANS DATED _____

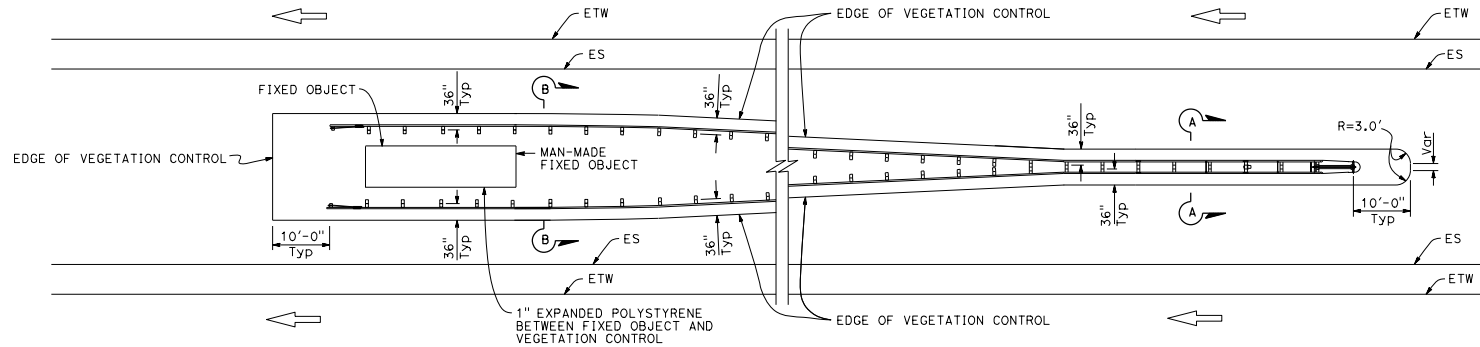

PLAN

Fixed object(s) between separate roadbeds
(One-Way Traffic)

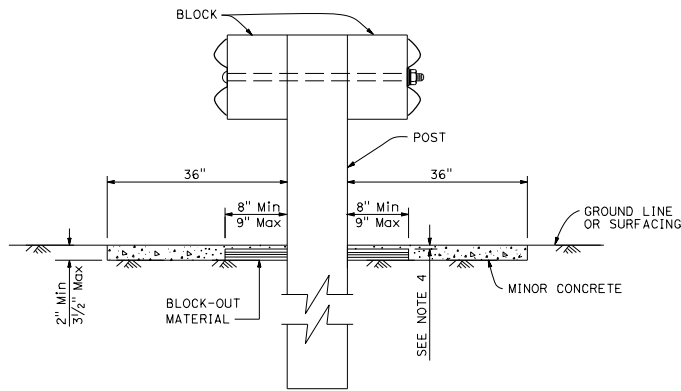

SECTION A-A

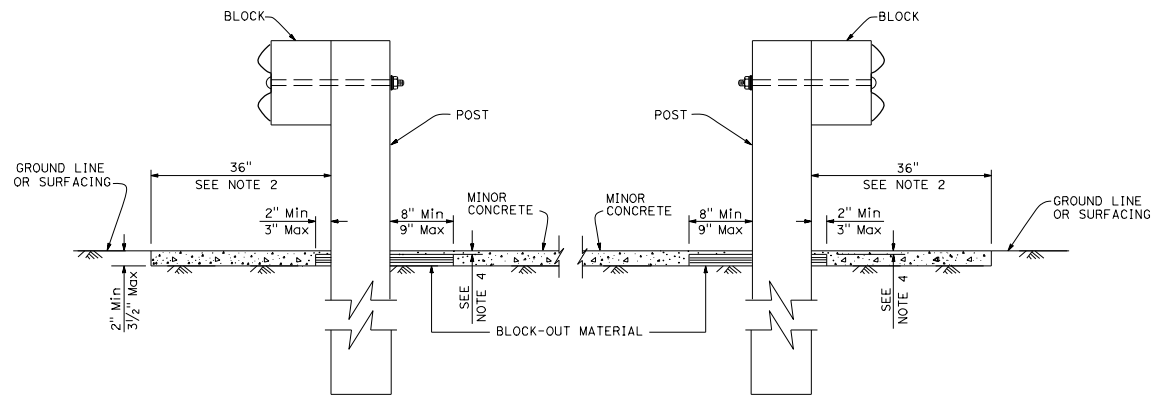

SECTION B-B

STATE OF CALIFORNIA
DEPARTMENT OF TRANSPORTATION

**MINOR CONCRETE VEGETATION CONTROL
GUARDRAIL SYSTEM
AT FIXED OBJECT**

NO SCALE

RSP A77N10 DATED APRIL 20, 2018 SUPERSEDES RSP A77N10 DATED JULY 21, 2017 AND
STANDARD PLAN A77N10 DATED OCTOBER 30, 2015 - PAGE 62 OF THE STANDARD PLANS BOOK DATED 2015.

REVISED STANDARD PLAN RSP A77N10

2015 REVISED STANDARD PLAN RSP A77N10

NOTES:

1. Minor concrete must be placed below anchor cable, bolt with nut and washer, or anchor plate.
2. Vegetation control must slope to drain water.
3. Concrete over block-out material depth, construct $\frac{3}{8}$ " Min to $\frac{3}{4}$ " Max.
4. This plan for vegetation control installation only.
5. For buried post end anchor, refer to Standard Plan A77T2.
6. For end anchor assembly, refer to Standard Plan A77S1.

DIST	COUNTY	ROUTE	POST MILES TOTAL PROJECT	SHEET TOTAL SHEETS
<i>Chi H. Wong</i> REGISTERED CIVIL ENGINEER				
April 20, 2018 PLANS APPROVAL DATE				
No. C054738 Exp. 12-31-19 CIVIL STATE OF CALIFORNIA				
<small>THE STATE OF CALIFORNIA OR ITS OFFICERS OR AGENTS SHALL NOT BE RESPONSIBLE FOR THE ACCURACY OR COMPLETENESS OF SCANNED COPIES OF THIS PLAN SHEET.</small>				

TO ACCOMPANY PLANS DATED _____

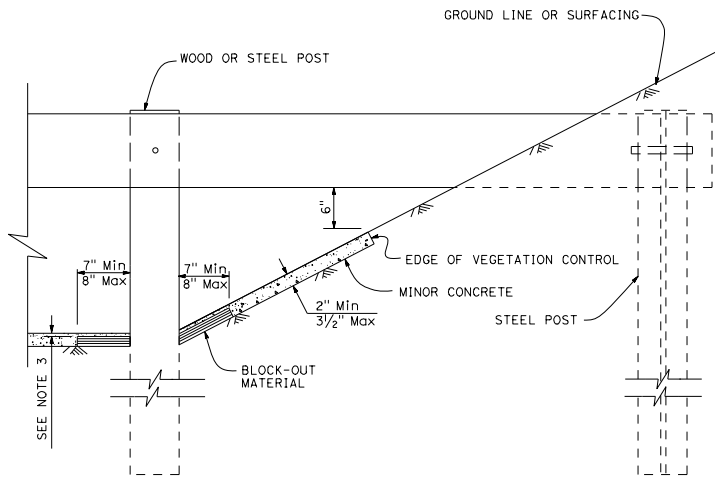

BURIED POST END ANCHOR

See Note 5

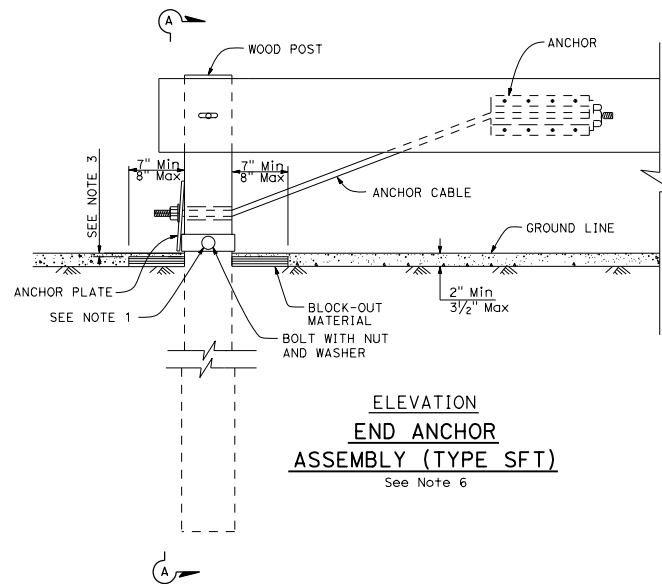

**ELEVATION
END ANCHOR
ASSEMBLY (TYPE SFT)**

See Note 6

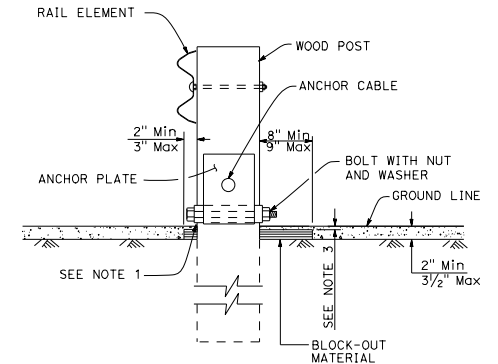

SECTION A-A

STATE OF CALIFORNIA
DEPARTMENT OF TRANSPORTATION

**MINOR CONCRETE VEGETATION CONTROL
GUARDRAIL SYSTEM
MISCELLANEOUS DETAILS**

NO SCALE

RSP A77N11 DATED APRIL 20, 2018 SUPERSEDES RSP A77N11
DATED JULY 21, 2017 THAT SUPPLEMENTS THE STANDARD PLANS BOOK DATED 2015.

REVISED STANDARD PLAN RSP A77N11

2015 REVISED STANDARD PLAN RSP A77N11

NOTES:

- Where dike is constructed under barrier, construct vegetation control to back edge of dike. Where paved shoulder is constructed within 24" of the post center, construct vegetation control to the edge of paved shoulder.
- For wood and steel post sizes, see Revised Standard Plans RSP A77N1 and RSP A77N2.
- For details not shown, see Revised Standard Plans RSP A77L1 and RSP A77L2.
- This plan for vegetation control installation only.
- Vegetation control must slope in direction of water flow.
- Place transverse and longitudinal overlap joint within the limits of vegetation control where applicable. No longitudinal overlap allowed in front of rail element on traffic side.
- Caulk longitudinal and transverse edges of vegetation control mat where it abuts to paved surface or man-made fixed objects, except guardrail posts.
- Where vegetation control is adjacent to a dike on a cut slope, construct vegetation control flush with the top edge of dike, and caulk.
- For fiber mat, install post collar at all posts and caulk all edges.
- Where the distance between center of post and hinge point is less than 30", construct vegetation control to 6" from the hinge point.

DIST	COUNTY	ROUTE	POST MILES TOTAL PROJECT	SHEET NO.	TOTAL SHEETS

Chi H. Wong
 REGISTERED CIVIL ENGINEER
 No. C054738
 APRIL 20, 2018
 PLANS APPROVAL DATE
THE STATE OF CALIFORNIA OR ITS OFFICERS OR AGENTS SHALL NOT BE RESPONSIBLE FOR THE ACCURACY OR COMPLETENESS OF SCANNED COPIES OF THIS PLAN SHEET.



TO ACCOMPANY PLANS DATED _____

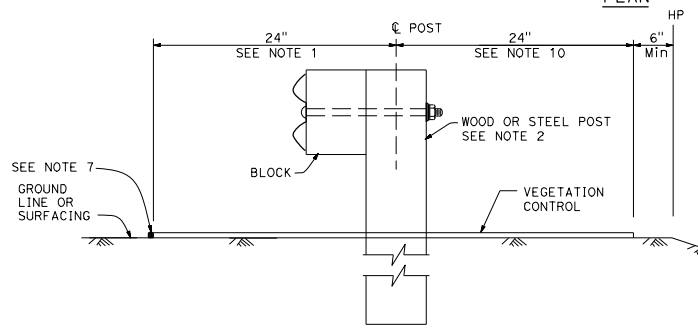
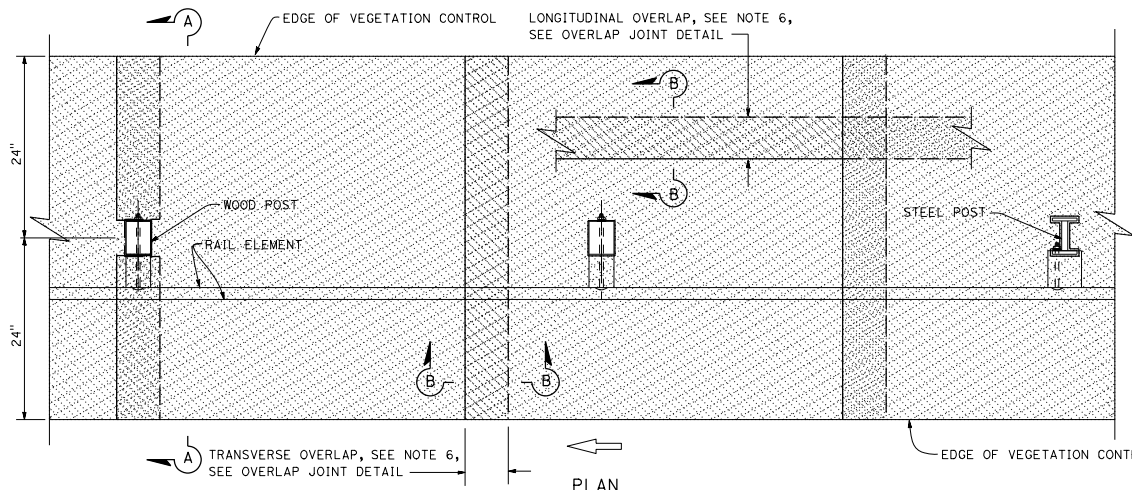

SECTION A-A
Without Existing Dike

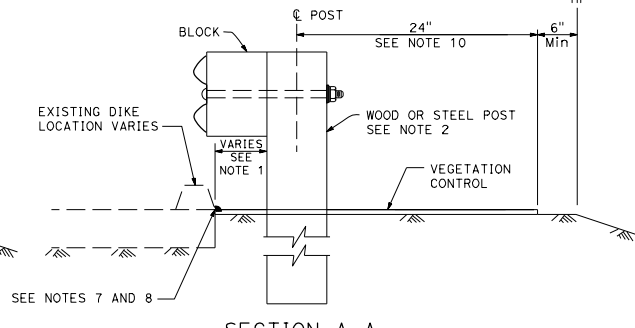

SECTION A-A
With Existing Dike

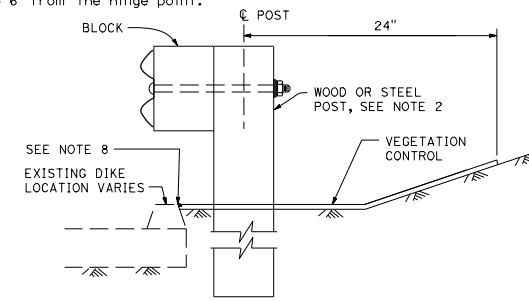

SECTION B-B
OVERLAP JOINT DETAIL
With Existing Dike on Cut Slope

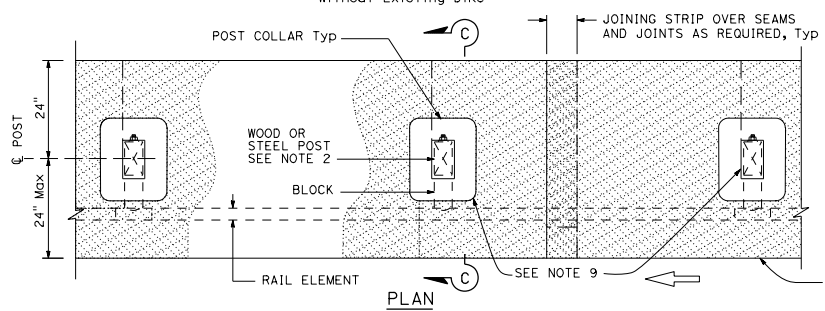

FIBER VEGETATION CONTROL POST COLLAR DETAIL

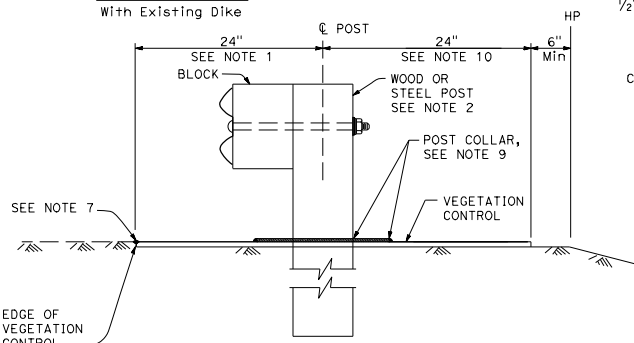

SECTION C-C

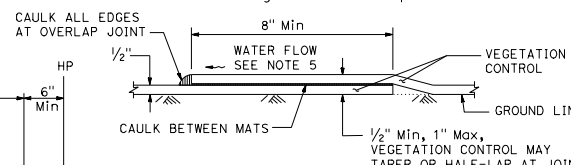

SECTION B-B
OVERLAP JOINT DETAIL
See Note 6

STATE OF CALIFORNIA
DEPARTMENT OF TRANSPORTATION

**FIBER OR RUBBER MAT
VEGETATION CONTROL
GUARDRAIL SYSTEM**

NO SCALE

RSP A77N12 DATED APRIL 20, 2018 SUPPLEMENTS THE STANDARD PLANS BOOK DATED 2015.

REVISED STANDARD PLAN RSP A77N12

2015 REVISED STANDARD PLAN RSP A77N12

DIST	COUNTY	ROUTE	POST MILES TOTAL PROJECT	SHEET NO.	TOTAL SHEETS

Chi H. Wong
 REGISTERED CIVIL ENGINEER
 No. C054738
 Exp. 12-31-19
 CIVIL
 STATE OF CALIFORNIA

April 20, 2018
 PLANS APPROVAL DATE
THE STATE OF CALIFORNIA OR ITS OFFICERS OR AGENTS SHALL NOT BE RESPONSIBLE FOR THE ACCURACY OR COMPLETENESS OF SCANNED COPIES OF THIS PLAN SHEET.

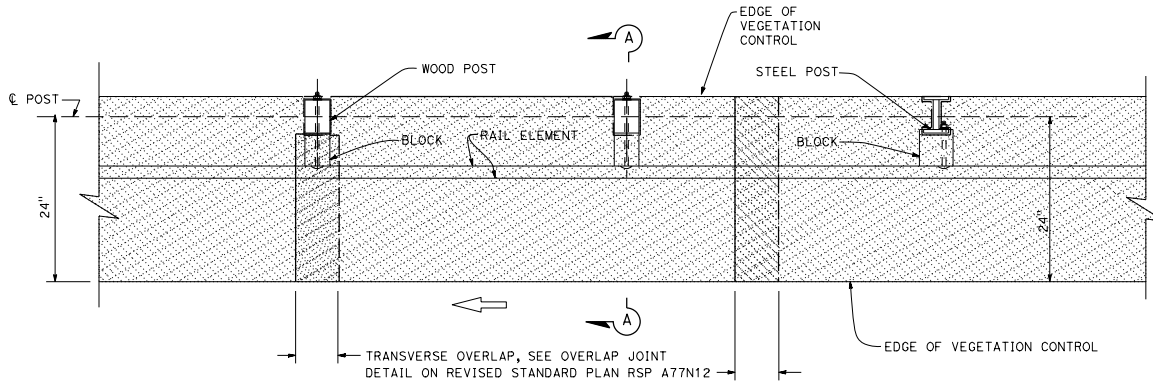

PLAN

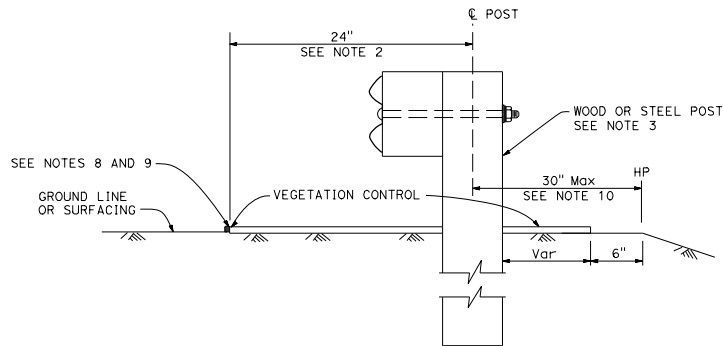

SECTION A-A

Without Existing Dike

NOTES:

- For additional vegetation control details, see Revised Standard Plan RSP A77N12.
- Where dike is constructed under barrier, construct vegetation control to back edge of dike. Where paved shoulder is constructed within 24" of the post center, construct vegetation control to the edge of paved shoulder.
- For wood and steel post sizes, see Revised Standard Plans RSP A77N1 and RSP A77N2.
- For details not shown, see Revised Standard Plans RSP A77L1 and RSP A77L2.
- This plan for vegetation control installation only.
- Vegetation control must slope in direction of water flow.
- Place transverse and longitudinal overlap joint within the limits of vegetation control where applicable.
- Caulk longitudinal and transverse edges of vegetation control mat where it abuts to paved surface or man-made fixed objects, except guardrail posts.
- Where vegetation control is adjacent to a dike on a cut slope, construct vegetation control flush with the top edge of dike, and caulk. See Revised Standard Plan RSP A77N12.
- Where the distance between center of post and hinge point is less than 30", construct vegetation control to 6" from the hinge point.

TO ACCOMPANY PLANS DATED _____

STATE OF CALIFORNIA
DEPARTMENT OF TRANSPORTATION

**FIBER OR RUBBER MAT VEGETATION CONTROL
GUARDRAIL SYSTEM
NARROW VEGETATION CONTROL INSTALLATION**

NO SCALE

RSP A77N13 DATED APRIL 20, 2018 SUPPLEMENTS THE STANDARD PLANS BOOK DATED 2015.

REVISED STANDARD PLAN RSP A77N13

2015 REVISED STANDARD PLAN RSP A77N13

DIST	COUNTY	ROUTE	POST MILES TOTAL PROJECT	SHEET TOTAL SHEETS
<i>Chi H. Wong</i> REGISTERED CIVIL ENGINEER				
April 20, 2018 PLANS APPROVAL DATE				
THE STATE OF CALIFORNIA OR ITS OFFICERS OR AGENTS SHALL NOT BE RESPONSIBLE FOR THE ACCURACY OR COMPLETENESS OF SCANNED COPIES OF THIS PLAN SHEET.				

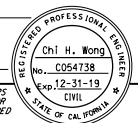

TO ACCOMPANY PLANS DATED _____

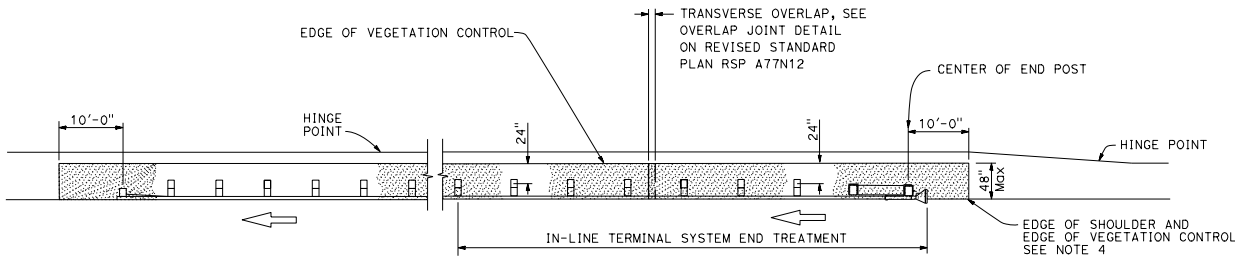

PLAN

NOTES:

1. For additional vegetation control details, see Revised Standard Plan RSP A77N12.
2. Vegetation control must slope in direction of water flow.
3. This plan for vegetation control installation only.
4. Caulk longitudinal and transverse edges of vegetation control mat where it abuts to paved surface or man-made fixed objects, except guardrail posts.

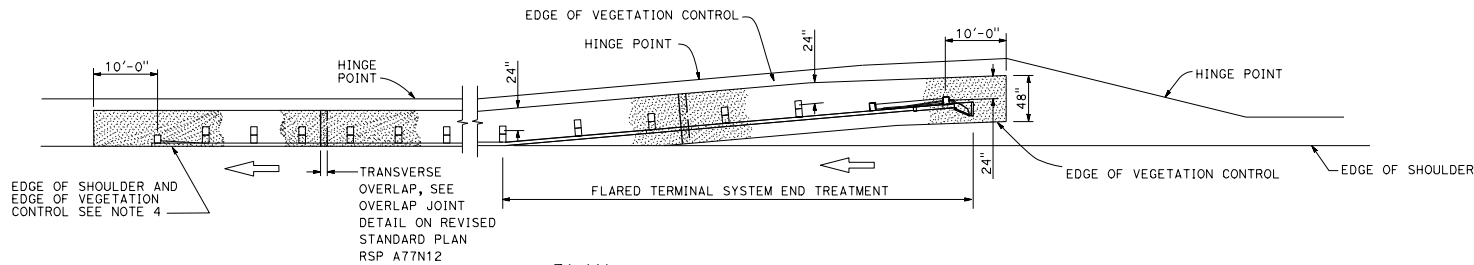

PLAN

STATE OF CALIFORNIA
DEPARTMENT OF TRANSPORTATION

**FIBER OR RUBBER MAT VEGETATION CONTROL
GUARDRAIL SYSTEM
FOR TERMINAL SYSTEM END TREATMENTS**

NO SCALE

RSP A77N14 DATED APRIL 20, 2018 SUPPLEMENTS THE STANDARD PLANS BOOK DATED 2015.

REVISED STANDARD PLAN RSP A77N14

2015 REVISED STANDARD PLAN RSP A77N14

DIST	COUNTY	ROUTE	POST MILES TOTAL PROJECT	SHEET TOTAL SHEETS
<i>Chi H. Wong</i> REGISTERED CIVIL ENGINEER No. C054738 APRIL 20, 2018 PLANS APPROVAL DATE <small>THE STATE OF CALIFORNIA OR ITS OFFICERS OR AGENTS SHALL NOT BE RESPONSIBLE FOR THE ACCURACY OR COMPLETENESS OF SCANNED COPIES OF THIS PLAN SHEET.</small>				
TO ACCOMPANY PLANS DATED _____				

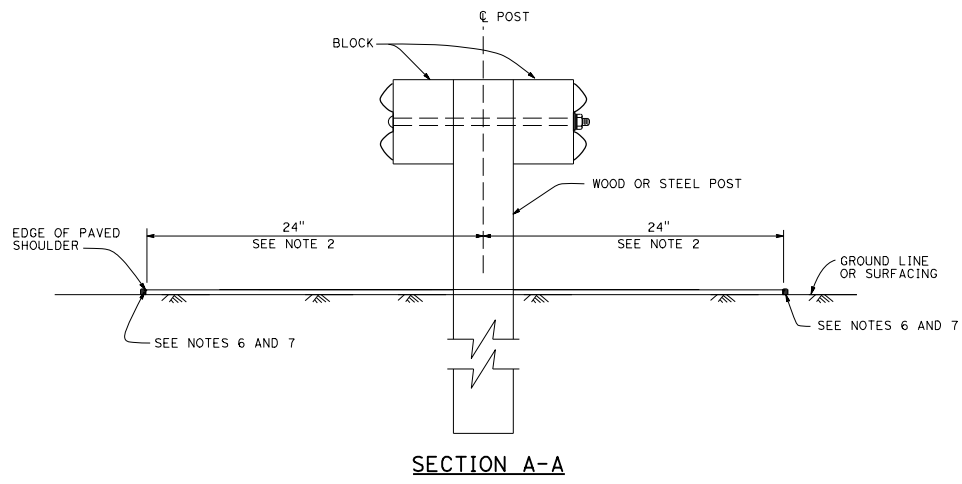
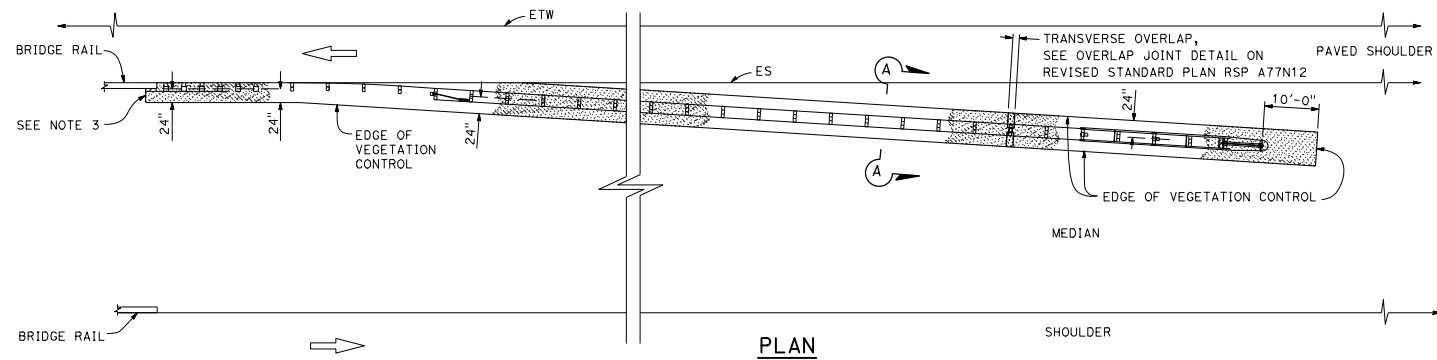
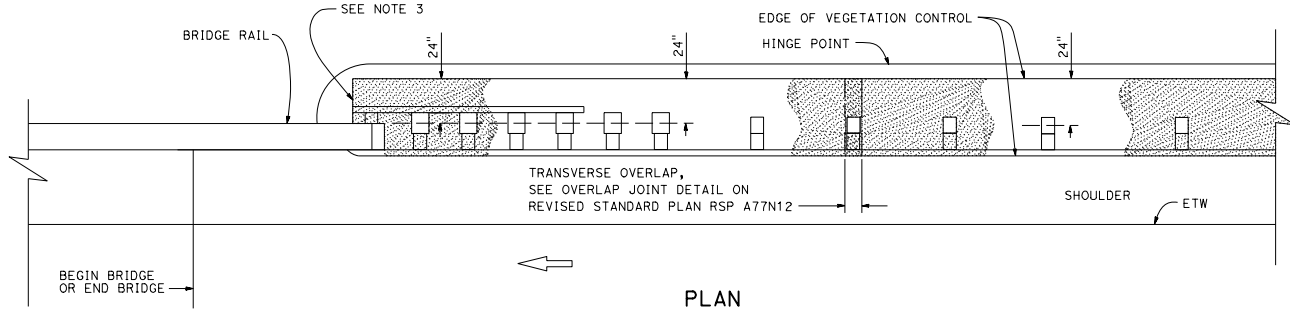
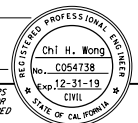

NOTES:

1. For additional vegetation control details, see Revised Standard Plan RSP A77N12.
2. Where dike is constructed under barrier, construct vegetation control to back edge of dike. Where paved shoulder is constructed within 24" of the post center, construct vegetation control to the edge of paved shoulder.
3. End vegetation control at end of backside rail element.
4. Vegetation control must slope in direction of water flow.
5. This plan for vegetation control installation only.
6. Caulk longitudinal and transverse edges of vegetation control mat where it abuts to paved surface or man-made fixed objects, except guardrail posts.
7. Where vegetation control is adjacent to a dike, see details on Revised Standard Plan RSP A77N12.

STATE OF CALIFORNIA
DEPARTMENT OF TRANSPORTATION
**FIBER OR RUBBER MAT
VEGETATION CONTROL
GUARDRAIL SYSTEM
AT STRUCTURE APPROACH**
NO SCALE

RSP A77N15 DATED APRIL 20, 2018 SUPPLEMENTS THE STANDARD PLANS BOOK DATED 2015.
REVISED STANDARD PLAN RSP A77N15

2015 REVISED STANDARD PLAN RSP A77N15

DIST	COUNTY	ROUTE	POST MILES TOTAL PROJECT	SHEET TOTAL NO. SHEETS
<i>Chi H. Wong</i> REGISTERED CIVIL ENGINEER				
April 20, 2018 PLANS APPROVAL DATE				
No. C054738 Exp. 12-31-19 CIVIL				
<small>THE STATE OF CALIFORNIA OR ITS OFFICERS OR AGENTS SHALL NOT BE RESPONSIBLE FOR THE ACCURACY OR COMPLETENESS OF SCANNED COPIES OF THIS PLAN SHEET.</small>				

TO ACCOMPANY PLANS DATED _____

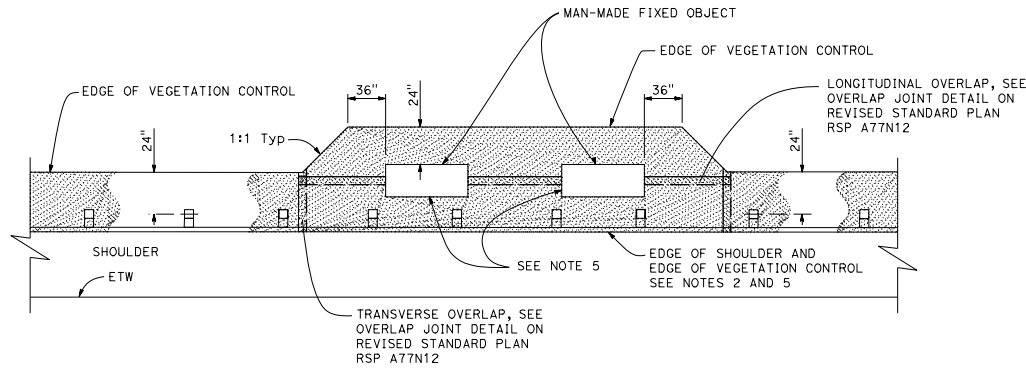

PLAN
Fixed object(s) on shoulder

NOTES:

1. For additional vegetation control details, see Revised Standard Plan RSP A77N12.
2. Where paved shoulder is constructed within 24" of the post center, construct vegetation control to the edge of paved shoulder.
3. Vegetation control must slope in direction of water flow.
4. This plan for vegetation control installation only.
5. Caulk longitudinal and transverse edges of vegetation control mat where it abuts to paved surface or man-made fixed objects, except guardrail posts.

STATE OF CALIFORNIA
DEPARTMENT OF TRANSPORTATION

**FIBER OR RUBBER MAT VEGETATION CONTROL
GUARDRAIL SYSTEM
AT FIXED OBJECT**

NO SCALE

RSP A77N16 DATED APRIL 20, 2018 SUPPLEMENTS THE STANDARD PLANS BOOK DATED 2015.

REVISED STANDARD PLAN RSP A77N16

2015 REVISED STANDARD PLAN RSP A77N16

Dist	COUNTY	ROUTE	POST MILES TOTAL PROJECT	SHEET NO.	TOTAL SHEETS

Chi H. Wong
 REGISTERED CIVIL ENGINEER
 No. C054738
 Exp. 12-31-19
 CIVIL
 STATE OF CALIFORNIA

April 20, 2018
 PLANS APPROVAL DATE
 THE STATE OF CALIFORNIA OR ITS OFFICERS OR AGENTS SHALL NOT BE RESPONSIBLE FOR THE ACCURACY OR COMPLETENESS OF SCANNED COPIES OF THIS PLAN SHEET.

TO ACCOMPANY PLANS DATED _____

NOTES:

- For additional vegetation control details, see Revised Standard Plan RSP A77N12.
- Where dike is constructed under barrier, construct vegetation control to back edge of dike. Where paved shoulder is constructed within 24" of the post center, construct vegetation control to the edge of paved shoulder.
- For wood and steel post sizes, see Revised Standard Plans RSP A77N1 and RSP A77N2.
- For details not shown, see Revised Standard Plans RSP A77L1 and RSP A77L2.
- This plan for vegetation control installation only.
- Vegetation control must slope in direction of water flow.
- Place transverse and longitudinal overlap joint within the limits of vegetation control where applicable.
- Caulk longitudinal and transverse edges of vegetation control mat where it abuts to paved surface or man-made fixed objects, except guardrail posts.
- Where vegetation control is adjacent to a dike, see details on Revised Standard Plan RSP A77N12.

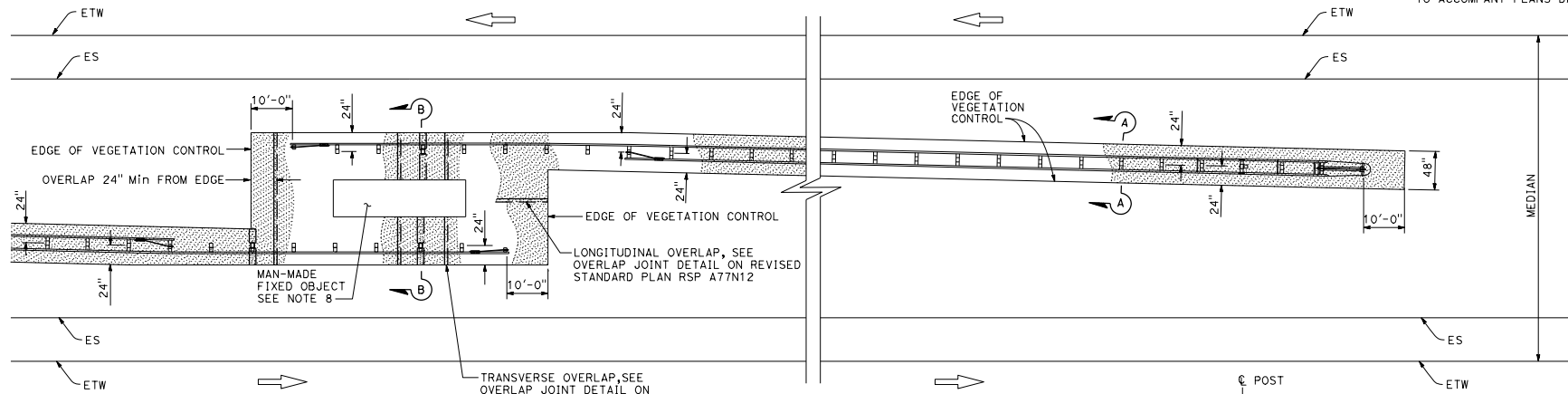

PLAN

Fixed object(s) in median

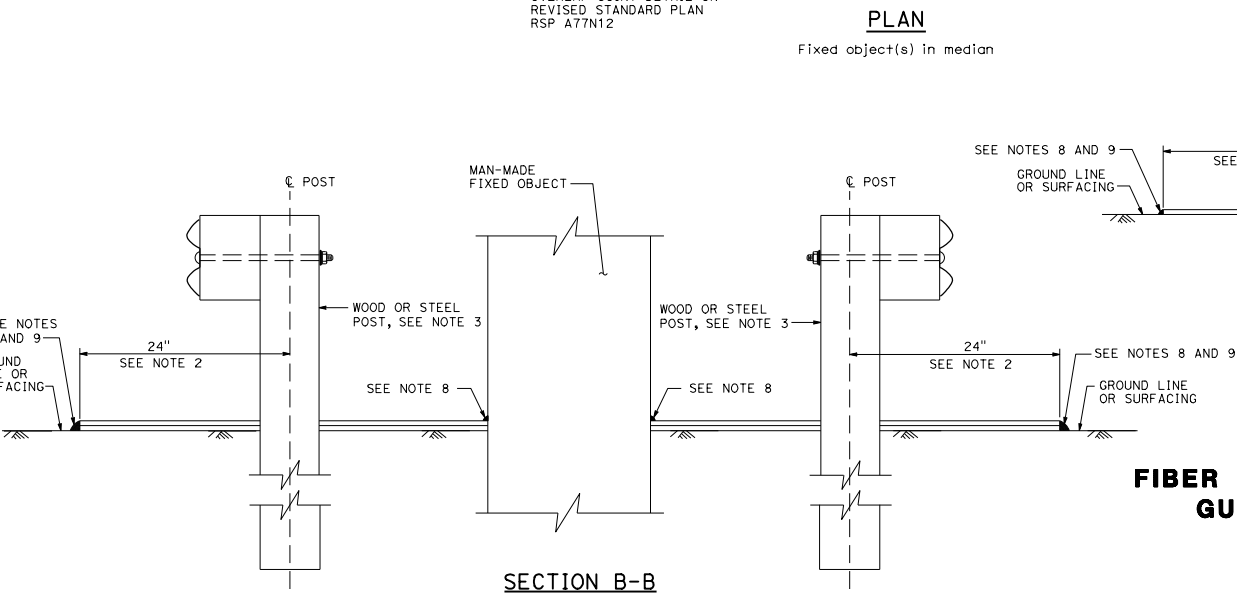

SECTION B-B

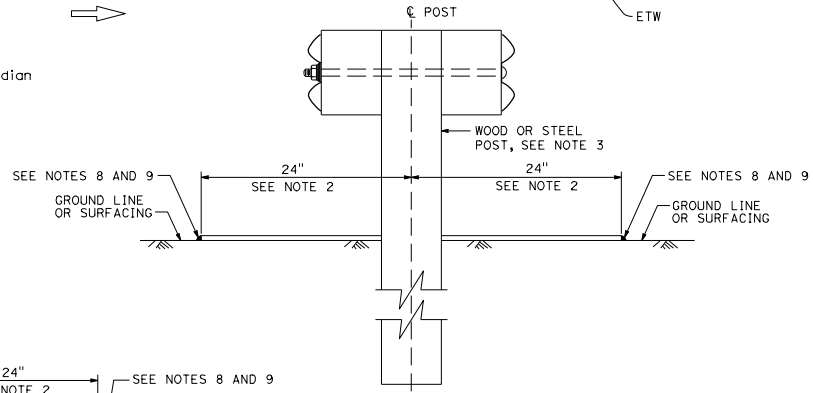

SECTION A-A

STATE OF CALIFORNIA
DEPARTMENT OF TRANSPORTATION
**FIBER OR RUBBER MAT VEGETATION CONTROL
GUARDRAIL SYSTEM AT FIXED OBJECT**

NO SCALE

RSP A77N17 DATED APRIL 20, 2018 SUPPLEMENTS THE STANDARD PLANS BOOK DATED 2015.

REVISED STANDARD PLAN RSP A77N17

2015 REVISED STANDARD PLAN RSP A77N17

DIST	COUNTY	ROUTE	POST MILES TOTAL PROJECT	SHEET TOTAL SHEETS

Chi H. Wong
 REGISTERED CIVIL ENGINEER
 No. C054738
 Exp. 12-31-19
 CIVIL
 STATE OF CALIFORNIA

April 20, 2018
 PLANS APPROVAL DATE
THE STATE OF CALIFORNIA OR ITS OFFICERS OR AGENTS SHALL NOT BE RESPONSIBLE FOR THE ACCURACY OR COMPLETENESS OF SCANNED COPIES OF THIS PLAN SHEET.

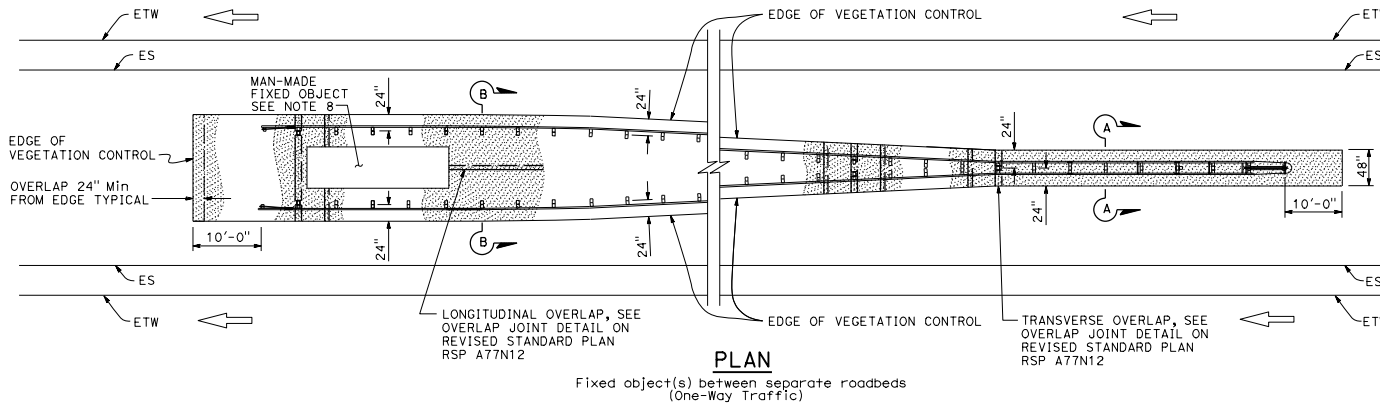

NOTES:

TO ACCOMPANY PLANS DATED _____

- For additional vegetation control details, see Revised Standard Plan RSP A77N12.
- Where dike is constructed under barrier, construct vegetation control to back edge of dike. Where paved shoulder is constructed within 24" of the post center, construct vegetation control to the edge of paved shoulder.
- For wood and steel post sizes, see Revised Standard Plans RSP A77N1 and RSP A77N2.
- For details not shown, see Revised Standard Plans RSP A77L1 and RSP A77L2.
- This plan for vegetation control installation only.
- Vegetation control must slope in direction of water flow.
- Place transverse and longitudinal overlap joint within the limits of vegetation control where applicable.
- Caulk longitudinal and transverse edges of vegetation control mat where it abuts to paved surface or man-made fixed objects, except guardrail posts.
- Where vegetation control is adjacent to a dike, see Revised Standard Plan RSP A77N12.

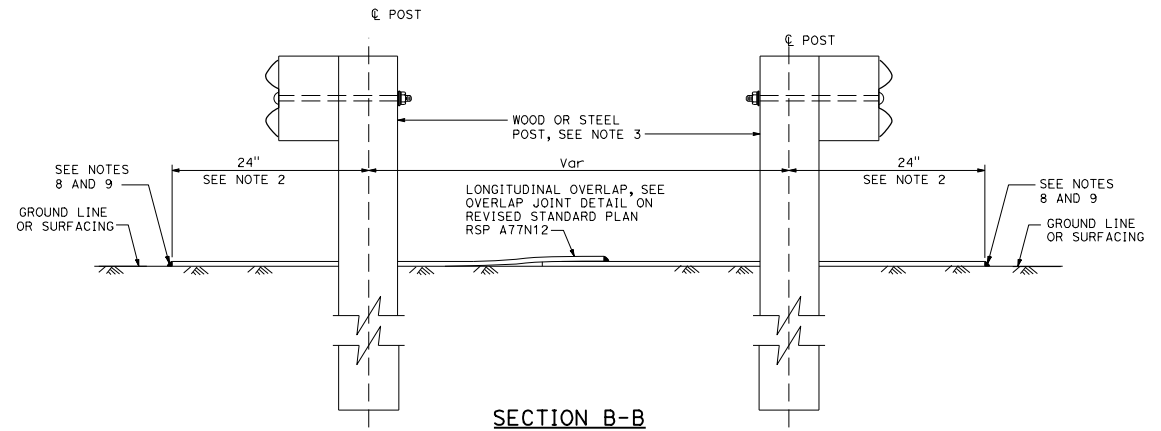
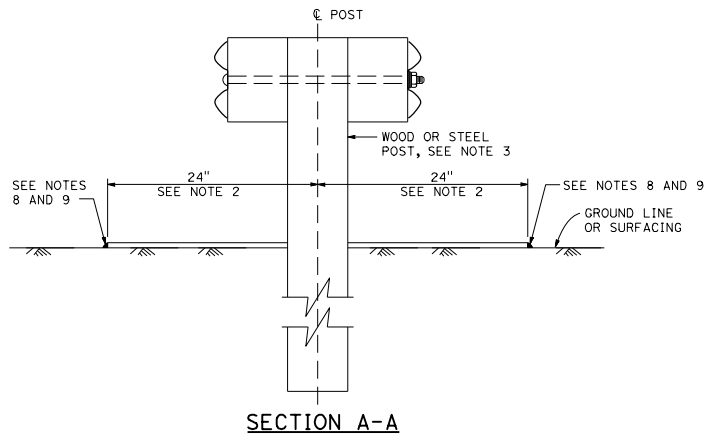

STATE OF CALIFORNIA
 DEPARTMENT OF TRANSPORTATION
**FIBER OR RUBBER MAT VEGETATION CONTROL
 GUARDRAIL SYSTEM
 AT FIXED OBJECT**
 NO SCALE

RSP A77N18 DATED APRIL 20, 2018 SUPPLEMENTS THE STANDARD PLANS BOOK DATED 2015.

REVISED STANDARD PLAN RSP A77N18

2015 REVISED STANDARD PLAN RSP A77N18

DIST	COUNTY	ROUTE	POST MILES TOTAL PROJECT	SHEET NO.	TOTAL SHEETS

Randell D. Hiatt
REGISTERED CIVIL ENGINEER
No. C50200
EXP. 6-30-17
CIVIL
STATE OF CALIFORNIA

January 20, 2017
PLANS APPROVAL DATE

THE STATE OF CALIFORNIA OR ITS OFFICERS OR AGENTS SHALL NOT BE RESPONSIBLE FOR THE ACCURACY OR COMPLETENESS OF SCANNED COPIES OF THIS PLAN SHEET.

TO ACCOMPANY PLANS DATED _____

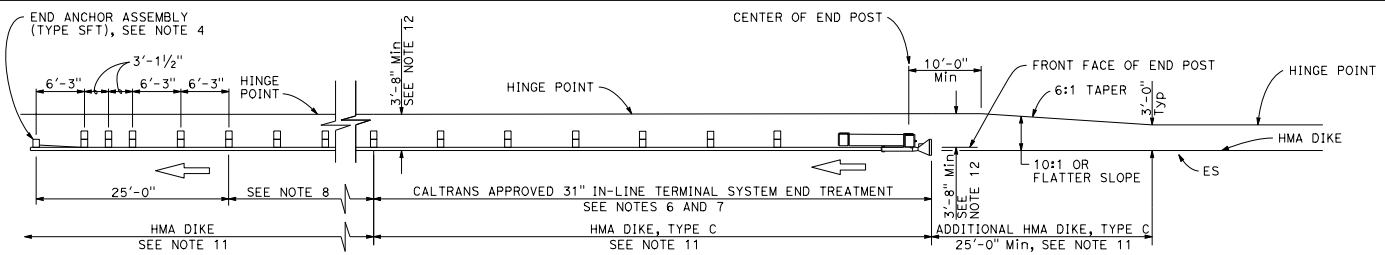

TYPE 11A LAYOUT

(Embankment MGS installation with 31" in-line end treatment at traffic approach end of railing)
See Note 5

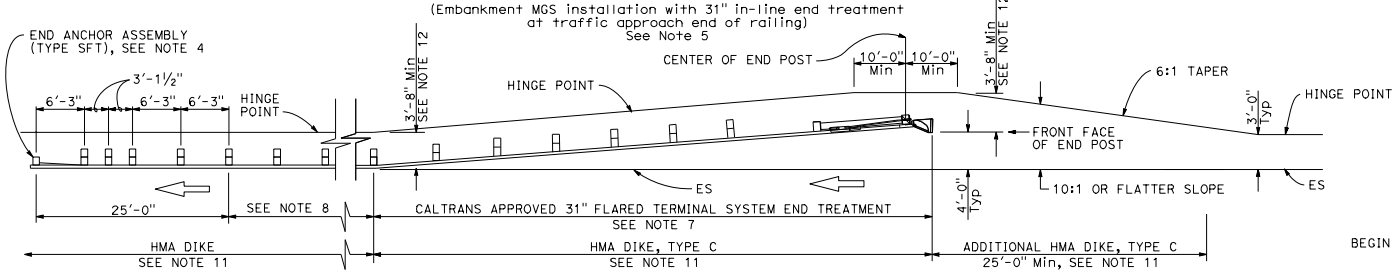

TYPE 11B LAYOUT

(Embankment MGS installation with 31" flared end treatment at traffic approach end of railing)
See Note 5

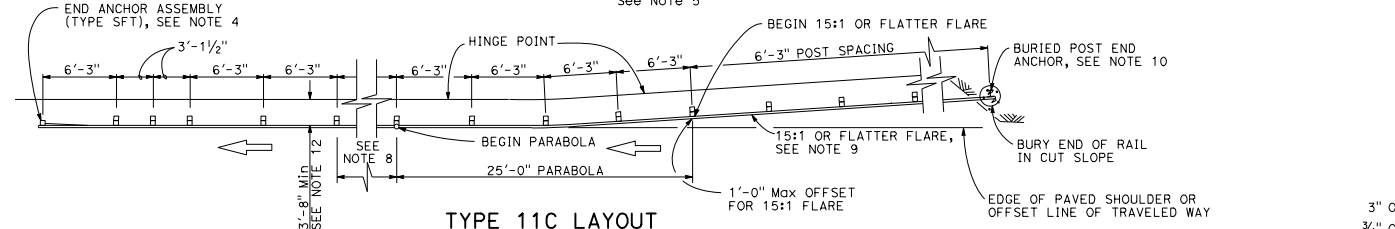

TYPE 11C LAYOUT

(Embankment MGS installation with buried end anchor treatment at traffic approach end of railing)
See Notes 5 and 11

- NOTES:**
- Line post, blocks and hardware to be used are shown on Revised Standard Plans RSP A77L1, RSP A77L2, RSP A77N1, RSP A77N2 and Standard Plan A77M1.
 - MGS post spacing to be 6'-3" center to center, except as otherwise noted.
 - Except as noted, line posts are 6" x 8" x 6'-0" wood with 6" x 8" x 1'-2" wood blocks, W6 x 8.5 or W6 x 9 steel posts, 6'-0" in length, with 6" x 8" x 1'-2" notched wood blocks or recycled plastic blocks may be used for 6" x 8" x 6'-0" wood post with 6" x 8" x 1'-2" wood blocks where applicable and when specified.
 - For End Anchor Assembly (Type SFT) details, see Standard Plan A77S1.
 - Layout Types 11A, 11B or 11C are typically used where MGS is recommended to shield embankment slopes and a crashworthy end treatment is required for only one direction of traffic.
 - 31" in-line terminal system end treatments are used where site conditions will not accommodate a flared end treatment.
 - The type of 31" terminal system end treatment to be used will be shown on the Project Plans.
 - Dependent on site conditions (embankment height and side slope), construction of additional MGS (length equal to multiples of 12'-6" with 6'-3" post spacing) may be advisable.
 - The 15:1 or flatter flare used with buried end anchors is based on the edge of the paved shoulder or offset line of edge of the traveled way. The length of MGS within the 15:1 or flatter flare is based on site conditions and should be a length equal to multiples of 12'-6".
 - For details of the buried post end anchor used with Type 11C Layout, see Standard Plan A77T2.
 - Where placement of dike is required with MGS installations, see Standard Plan A77N4 for dike positioning details.
 - Use this offset for 8-inch block. For 12-inch block, use 4'-0" Min offset.

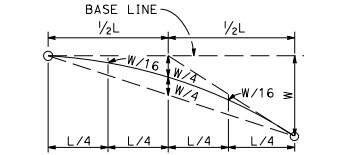

TYPICAL PARABOLIC LAYOUT

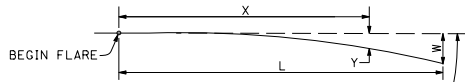

PARABOLIC FLARE OFFSETS

BASE LINE (EDGE OF PAVED SHOULDER OR OFFSET LINE OF EDGE OF TRAVELED WAY)

Y = OFFSET FROM BASE LINE
W = MAXIMUM OFFSET
X = DISTANCE ALONG BASE LINE
L = LENGTH OF FLARE

$$Y = \frac{WX^2}{L^2}$$

TYPICAL FLARE OFFSETS FOR 1 FOOT Max END OFFSET

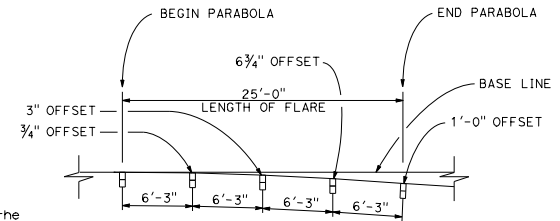

TYPICAL FLARE OFFSETS FOR 1 FOOT Max END OFFSET

STATE OF CALIFORNIA
DEPARTMENT OF TRANSPORTATION

MIDWEST GUARDRAIL SYSTEM TYPICAL LAYOUTS FOR EMBANKMENTS

NO SCALE

RSP A77P1 DATED JANUARY 20, 2017 SUPERSEDES STANDARD PLAN A77P1 DATED OCTOBER 30, 2015 - PAGE 63 OF THE STANDARD PLANS BOOK DATED 2015.

REVISED STANDARD PLAN RSP A77P1

2015 REVISED STANDARD PLAN RSP A77P1

DIST	COUNTY	ROUTE	POST MILES TOTAL PROJECT	SHEET TOTAL SHEETS

Randell D. Hiatt
REGISTERED CIVIL ENGINEER

January 20, 2017
PLANS APPROVAL DATE

REGISTERED PROFESSIONAL ENGINEER
Randell D. Hiatt
No. CS0200
Exp. 6-30-17
CIVIL
STATE OF CALIFORNIA

THE STATE OF CALIFORNIA OR ITS OFFICERS OR AGENTS SHALL NOT BE RESPONSIBLE FOR THE ACCURACY OR COMPLETENESS OF SCANNED COPIES OF THIS PLAN SHEET.

TO ACCOMPANY PLANS DATED _____

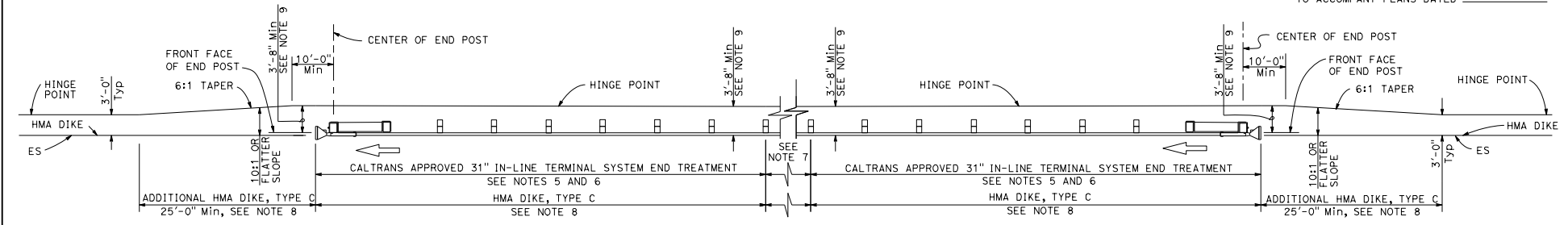

TYPE 11D LAYOUT

(Embankment MGS installation with 31" in-line end treatment at each end of railing)
See Note 4

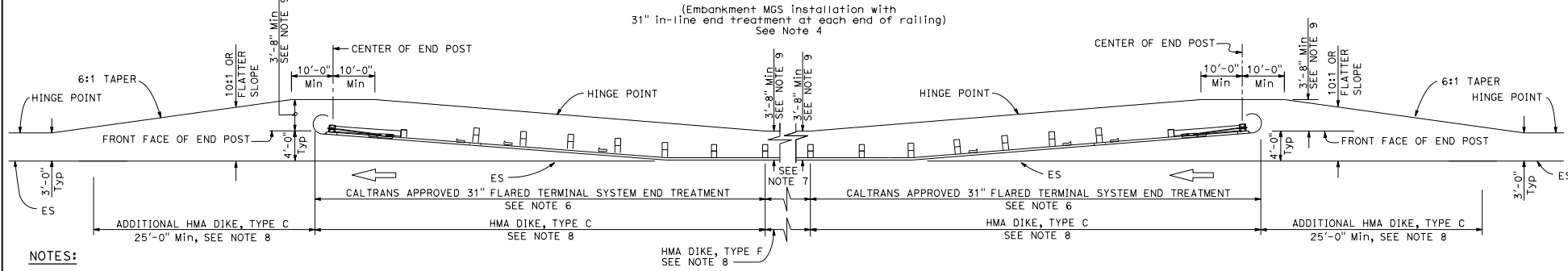

TYPE 11E LAYOUT

(Embankment MGS installation with 31" flared end treatment at each end of railing)
See Note 4

- NOTES:**
- Line post, blocks and hardware to be used are shown on Revised Standard Plans RSP A77L1, RSP A77L2, RSP A77N1, RSP A77N2 and Standard Plan A77M1.
 - MGS post spacing to be 6'-3" center to center, except as otherwise noted.
 - Except as noted, line posts are 6" x 8" x 6'-0" wood with 6" x 8" x 1'-2" wood blocks, W6 x 8.5 or W6 x 9 steel posts, 6'-0" in length, with 6" x 8" x 1'-2" notched wood blocks or plastic blocks may be used for 6" x 8" x 6'-0" wood post with 6" x 8" x 1'-2" wood blocks where applicable and when specified.
 - Layout Types 11D through 11L, shown on the A77P Series of Standard Plans, are typically used where MGS is recommended to shield embankment slopes and a crashworthy 31" end treatment is required for both directions of traffic.
 - 31" in-line terminal system end treatments are used where site conditions will not accommodate a flared end treatment.
 - The type of 31" terminal system end treatment to be used will be shown on the Project Plans.
 - Dependent on site conditions (embankment height and side slope), construction of additional MGS (length equal to multiples of 12'-6" with 6'-3" post spacing) may be advisable.
 - Where placement of dike is required with MGS installations, see Standard Plan A77N4 for dike positioning details.
 - Use this offset for 8-inch block. For 12-inch block, use 4'-0" Min offset.

STATE OF CALIFORNIA
DEPARTMENT OF TRANSPORTATION

**MIDWEST GUARDRAIL SYSTEM
TYPICAL LAYOUTS FOR
EMBANKMENTS**

NO SCALE

RSP A77P2 DATED JANUARY 20, 2017 SUPERSEDES STANDARD PLAN A77P2
DATED OCTOBER 30, 2015 - PAGE 64 OF THE STANDARD PLANS BOOK DATED 2015.

REVISED STANDARD PLAN RSP A77P2

2015 REVISED STANDARD PLAN RSP A77P2

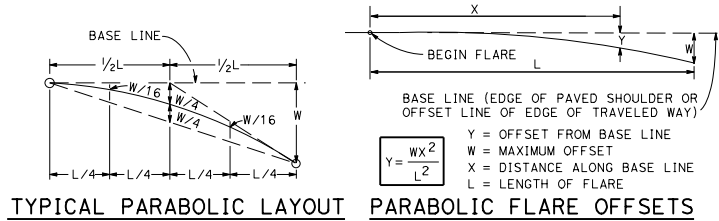

DIST	COUNTY	ROUTE	POST MILES TOTAL PROJECT	SHEET TOTAL SHEETS

Randell D. Hiatt
REGISTERED CIVIL ENGINEER

January 20, 2017
PLANS APPROVAL DATE

THE STATE OF CALIFORNIA OR ITS OFFICERS OR AGENTS SHALL NOT BE RESPONSIBLE FOR THE ACCURACY OR COMPLETENESS OF SCANNED COPIES OF THIS PLAN SHEET.

REGISTERED PROFESSIONAL ENGINEER
No. C50200
Exp. 6-30-17
CIVIL
STATE OF CALIFORNIA

TO ACCOMPANY PLANS DATED _____

2015 REVISED STANDARD PLAN RSP A77P3

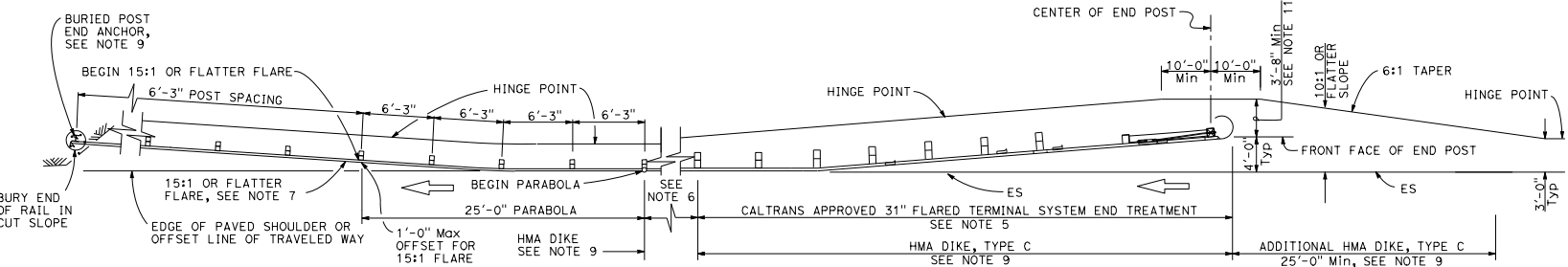
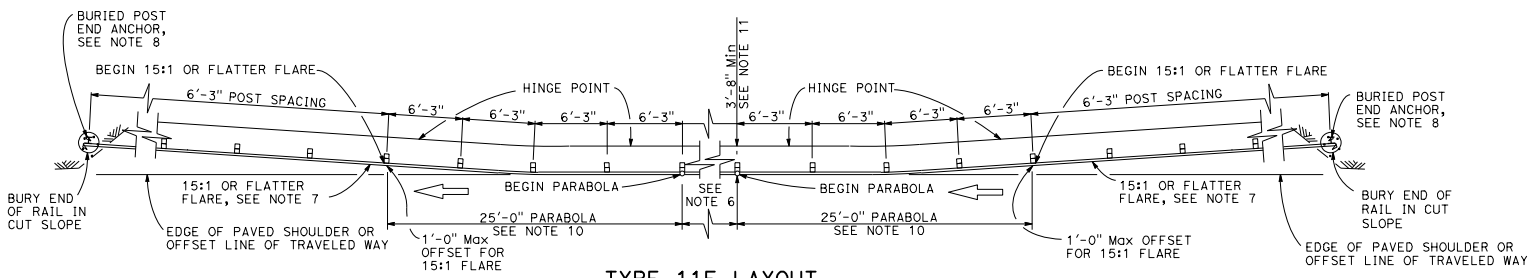

NOTES:

- Line post, blocks and hardware to be used are shown on Revised Standard Plans RSP A77L1, RSP A77L2, RSP A77N1, RSP A77N2 and Standard Plan A77M1.
- MGS post spacing to be 6'-3" center to center, except as otherwise noted.
- Except as noted, line posts are 6" x 8" x 6'-0" wood with 6" x 8" x 1'-2" wood blocks, W6 x 8.5 or W6 x 9 steel posts, 6'-0" in length, with 6" x 8" x 1'-2" notched wood blocks or plastic blocks may be used for 6" x 8" x 6'-0" wood post with 6" x 8" x 1'-2" wood blocks where applicable and when specified.
- Layout Types 11D through 11L, shown on the A77P Series of Standard Plans, are typically used where MGS is recommended to shield embankment slopes and a crashworthy 31" end treatment is required for both directions of traffic.
- The type of 31" terminal system end treatment to be used will be shown on the Project Plans.
- Dependent on site conditions (embankment height and side slope), construction of additional MGS (length equal to multiples of 12'-6" with 6'-3" post spacing) may be advisable.
- The 15:1 or flatter flare used with buried end anchors is based on the edge of the paved shoulder or offset line of edge of the traveled way. The length of MGS within the 15:1 or flatter flare is based on site conditions and should be a length equal to multiples of 12'-6".
- For details of the buried post end anchor used with Type 11F and 11G Layouts, see Standard Plan A77T2.
- Where placement of dike is required with MGS installations, see Standard Plan A77N4 for dike positioning details.
- For typical flare offsets for 25'-0" length parabola with maximum offset of 1'-0", see Revised Standard Plan RSP A77P1.
- Use this offset for 8-inch block. For 12-inch block, use 4'-0" Min offset.

STATE OF CALIFORNIA
DEPARTMENT OF TRANSPORTATION

MIDWEST GUARDRAIL SYSTEM
TYPICAL LAYOUTS FOR
EMBANKMENTS

NO SCALE

RSP A77P3 DATED JANUARY 20, 2017 SUPERSEDES STANDARD PLAN A77P3
DATED OCTOBER 30, 2015 - PAGE 65 OF THE STANDARD PLANS BOOK DATED 2015.

REVISED STANDARD PLAN RSP A77P3

DIST	COUNTY	ROUTE	POST MILES TOTAL PROJECT	SHEET NO.	TOTAL SHEETS

Randell D. Hiatt
REGISTERED CIVIL ENGINEER

January 20, 2017
PLANS APPROVAL DATE

No. C50200
Exp. 6-30-17
CIVIL
STATE OF CALIFORNIA

THE STATE OF CALIFORNIA OR ITS OFFICERS OR AGENTS SHALL NOT BE RESPONSIBLE FOR THE ACCURACY OR COMPLETENESS OF SCANNED COPIES OF THIS PLAN SHEET.

TO ACCOMPANY PLANS DATED _____

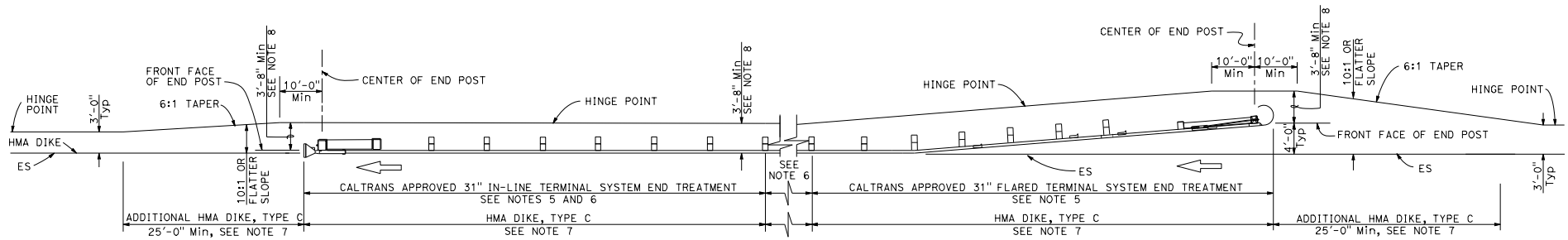

TYPE 11H LAYOUT

(Embankment MGS installation with 31" flared end treatment and 31" in-line end treatment at the ends of railing)
See Notes 4 and 7

NOTES:

1. Line post, blocks and hardware to be used are shown on Revised Standard Plans RSP A77L1, RSP A77L2, RSP A77N1, RSP A77N2 and Standard Plan A77M1.
2. MGS post spacing to be 6'-3" center to center, except as otherwise noted.
3. Except as noted, line posts are 6" x 8" x 6'-0" wood with 6" x 8" x 1'-2" wood blocks, W6 x 8.5 or W6 x 9 steel posts, 6'-0" in length, with 6" x 8" x 1'-2" notched wood blocks or plastic blocks may be used for 6" x 8" x 6'-0" wood post with 6" x 8" x 1'-2" wood blocks where applicable and when specified.
4. Layout Types 11D through 11L, shown on the A77P Series of Standard Plans, are typically used where MGS is recommended to shield embankment slopes and a crashworthy 31" end treatment is required for both directions of traffic.
5. The type of 31" terminal system end treatment to be used will be shown on the Project Plans.
6. Dependent on site conditions (embankment height and side slope), construction of additional MGS (length equal to multiples of 12'-6" with 6'-3" post spacing) may be advisable.
7. Where placement of dike is required with MGS installations, see Standard Plan A77N4 for dike positioning details.
8. Use this offset for 8-inch block. For 12-inch block, use 4'-0" Min offset.

STATE OF CALIFORNIA
DEPARTMENT OF TRANSPORTATION

**MIDWEST GUARDRAIL SYSTEM
TYPICAL LAYOUTS FOR
EMBANKMENTS**

NO SCALE

RSP A77P4 DATED JANUARY 20, 2017 SUPERSEDES STANDARD PLAN A77P4
DATED OCTOBER 30, 2015 - PAGE 66 OF THE STANDARD PLANS BOOK DATED 2015.

REVISED STANDARD PLAN RSP A77P4

2015 REVISED STANDARD PLAN RSP A77P4

DIST	COUNTY	ROUTE	POST MILES TOTAL PROJECT	SHEET TOTAL SHEETS

Randell D. Hiatt
REGISTERED CIVIL ENGINEER

January 20, 2017
PLANS APPROVAL DATE

PLANS APPROVAL NO. C50200
EXP. 6-30-17
CIVIL

REGISTERED PROFESSIONAL ENGINEER
STATE OF CALIFORNIA

THE STATE OF CALIFORNIA OR ITS OFFICERS OR AGENTS SHALL NOT BE RESPONSIBLE FOR THE ACCURACY OR COMPLETENESS OF SCANNED COPIES OF THIS PLAN SHEET.

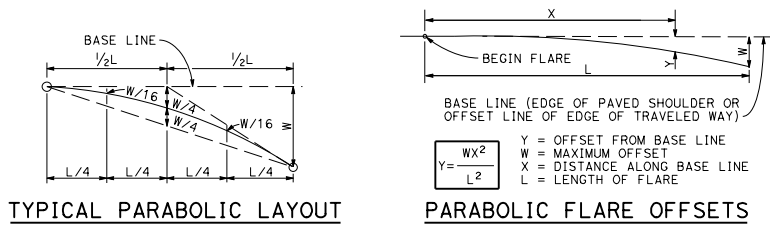

TYPICAL PARABOLIC LAYOUT

PARABOLIC FLARE OFFSETS

TO ACCOMPANY PLANS DATED _____

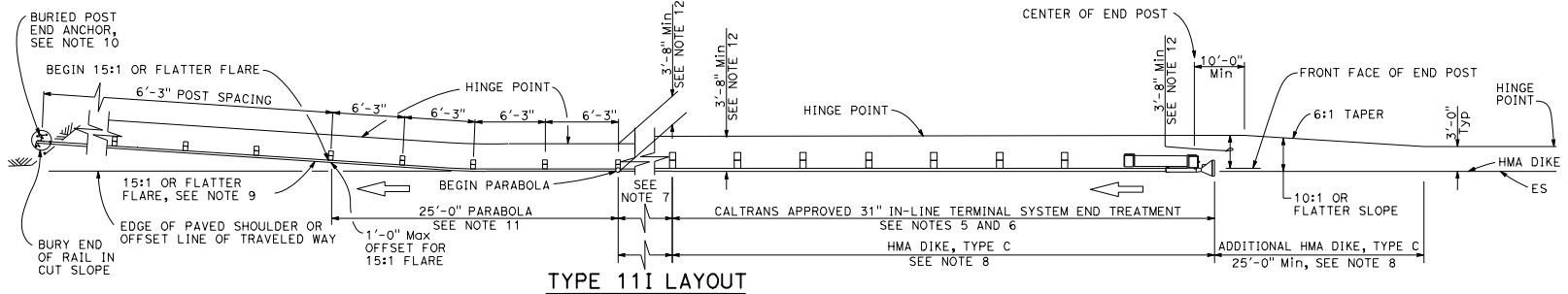

TYPE 11I LAYOUT

(Embankment MGS installation with 31" in-line end treatment and a buried end anchor treatment at the ends of railing)
See Note 4

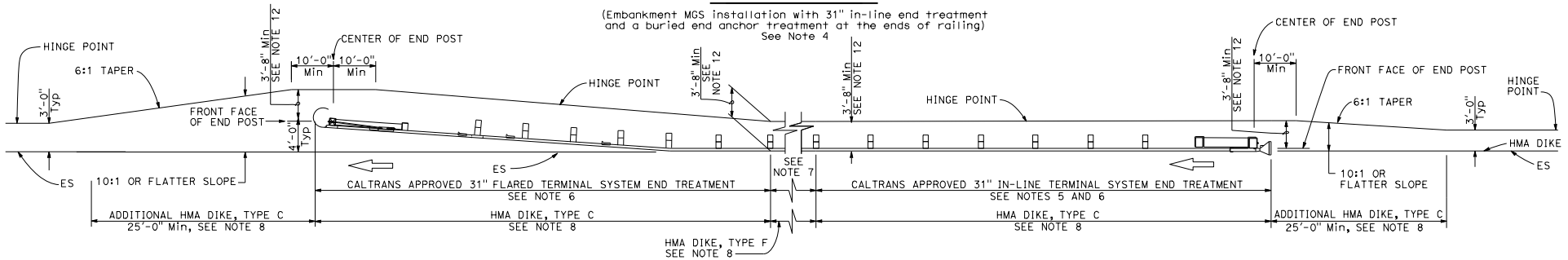

TYPE 11J LAYOUT

(Embankment MGS installation with 31" in-line end treatment and 31" flared end treatment at the ends of railing)
See Note 4

NOTES:

- Line post, blocks and hardware to be used are shown on Revised Standard Plans RSP A77L1, RSP A77L2, RSP A77N1, RSP A77N2 and Standard Plan A77M1.
- MGS post spacing to be 6'-3" center to center, except as otherwise noted.
- Except as noted, line posts are 6" x 8" x 6'-0" wood with 6" x 8" x 1'-2" wood blocks, W6 x 8.5 or W6 x 9 steel posts, 6'-0" in length, with 6" x 8" x 1'-2" notched wood blocks or plastic blocks may be used for 6" x 8" x 6'-0" wood post with 6" x 8" x 1'-2" wood blocks where applicable and when specified.
- Layout Types 11D through 11L, shown on the A77P Series of Standard Plans, are typically used where MGS is recommended to shield embankment slopes and a crashworthy 31" end treatment is required for both directions of traffic.
- 31" in-line terminal system end treatments are used where site conditions will not accommodate a 31" flared end treatment.
- The type of 31" terminal system end treatment to be used will be shown on the Project Plans.
- Dependent on site conditions (embankment height and side slope), construction of additional MGS (length equal to multiples of 12'-6" with 6'-3" post spacing) may be advisable.
- Where placement of dike is required with MGS installations, see Standard Plan A77N4 for dike positioning details.
- The 15:1 or flatter flare used with buried end anchors is based on the edge of the paved shoulder or offset line of edge of the traveled way. The length of MGS within the 15:1 or flatter flare is based on site conditions and should be a length equal to multiples of 12'-6".
- For details of the buried post end anchor used with Type 11I Layout, see Standard Plan A77T2.
- For typical flare offsets for 25'-0" length parabola with maximum offset of 1'-0", see Revised Standard Plan RSP A77P1.
- Use this offset for 8-inch block. For 12-inch block, use 4'-0" Min offset.

STATE OF CALIFORNIA
DEPARTMENT OF TRANSPORTATION
**MIDWEST GUARDRAIL SYSTEM
TYPICAL LAYOUTS FOR
EMBANKMENTS**

NO SCALE

RSP A77P5 DATED JANUARY 20, 2017 SUPERSEDES STANDARD PLAN A77P5
DATED OCTOBER 30, 2015 - PAGE 67 OF THE STANDARD PLANS BOOK DATED 2015.

REVISED STANDARD PLAN RSP A77P5

2015 REVISED STANDARD PLAN RSP A77P5

DIST	COUNTY	ROUTE	POST MILES TOTAL PROJECT	SHEET TOTAL SHEETS

Randell D. Hiatt
REGISTERED CIVIL ENGINEER

January 20, 2017
PLANS APPROVAL DATE

THE STATE OF CALIFORNIA OR ITS OFFICERS OR AGENTS SHALL NOT BE RESPONSIBLE FOR THE ACCURACY OR COMPLETENESS OF SCANNED COPIES OF THIS PLAN SHEET.

REGISTERED PROFESSIONAL ENGINEER
No. C50200
Exp. 6-30-17
CIVIL
STATE OF CALIFORNIA

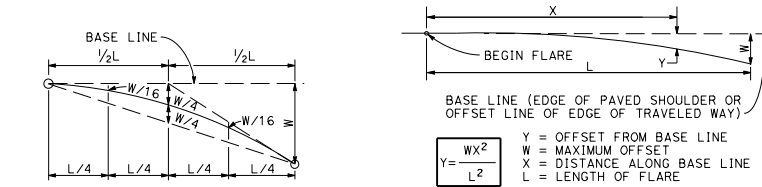

TO ACCOMPANY PLANS DATED _____

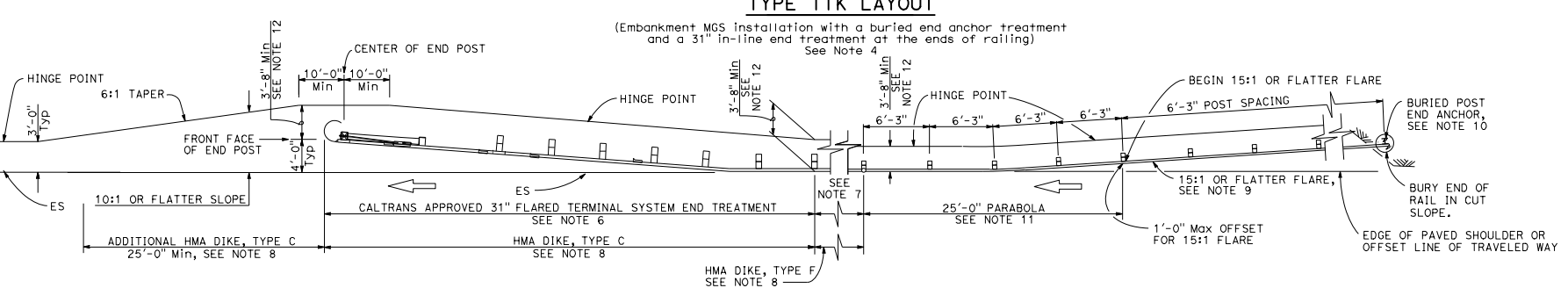
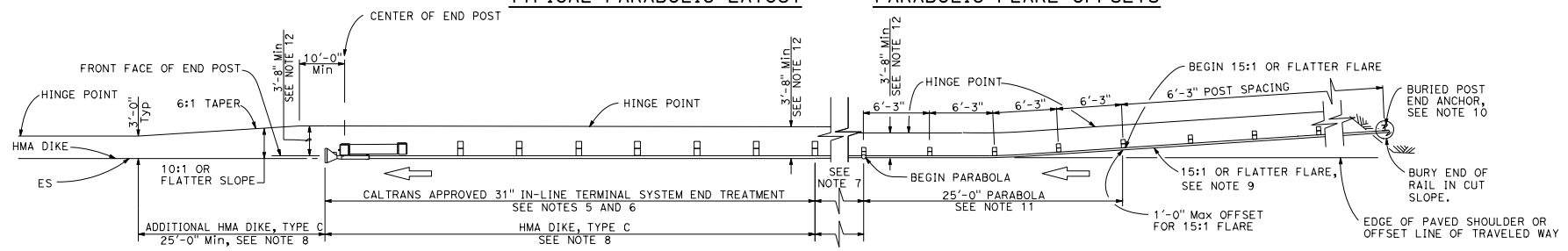

- NOTES:**
- Line post, blocks and hardware to be used are shown on Revised Standard Plans RSP A77L1, RSP A77L2, RSP A77N1, RSP A77N2 and Standard Plan A77M1.
 - MGS post spacing to be 6'-3" center to center, except as otherwise noted.
 - Except as noted, line posts are 6" x 8" x 6'-0" wood with 6" x 8" x 1'-2" wood blocks, W6 x 8.5 or W6 x 9 steel posts, 6'-0" in length, with 6" x 8" x 1'-2" notched wood blocks or plastic blocks may be used for 6" x 8" x 6'-0" wood post with 6" x 8" x 1'-2" wood blocks where applicable and when specified.
 - Layout Types 11D through 11L, shown on the A77P Series of Standard Plans, are typically used where MGS is recommended to shield embankment slopes and a crashworthy 31" end treatment is required for both directions of traffic.
 - 31" in-line terminal system end treatments are used where site conditions will not accommodate a 31" flared end treatment.
 - The type of 31" terminal system end treatment to be used will be shown on the Project Plans.

- Dependent on site conditions (embankment height and side slope), construction of additional MGS (length equal to multiples of 12'-6" with 6'-3" post spacing) may be advisable.
- Where placement of dike is required with MGS installations, see Standard Plan A77N4 for dike positioning details.
- The 15:1 or flatter flare used with buried end anchors is based on the edge of the paved shoulder or offset line of edge of the traveled way. The length of MGS within the 15:1 or flatter flare is based on site conditions and should be a length equal to multiples of 12'-6".
- For details of the buried post end anchor used with Type 11K and 11L Layouts, see Standard Plan A77T2.
- For typical flare offsets for 25'-0" length parabola with maximum offset of 1'-0", see Revised Standard Plan RSP A77P1.
- Use this offset for 8" block. For 12" block, use 4'-0" Min offset.

STATE OF CALIFORNIA
DEPARTMENT OF TRANSPORTATION

**MIDWEST GUARDRAIL SYSTEM
TYPICAL LAYOUTS FOR
EMBANKMENTS**

NO SCALE

RSP A77P6 DATED JANUARY 20, 2017 SUPERSEDES STANDARD PLAN A77P6
DATED OCTOBER 30, 2015 - PAGE 68 OF THE STANDARD PLANS BOOK DATED 2015.

REVISED STANDARD PLAN RSP A77P6

2015 REVISED STANDARD PLAN RSP A77P6

DIST	COUNTY	ROUTE	POST MILES TOTAL PROJECT	SHEET NO.	TOTAL SHEETS

Randell D. Hiatt
REGISTERED CIVIL ENGINEER

January 20, 2017
PLANS APPROVAL DATE

REGISTERED PROFESSIONAL ENGINEER
Randell D. Hiatt
No. C50200
Exp. 6-30-17
CIVIL
STATE OF CALIFORNIA

THE STATE OF CALIFORNIA OR ITS OFFICERS OR AGENCIES SHALL NOT BE RESPONSIBLE FOR THE ACCURACY OR COMPLETENESS OF SCANNED COPIES OF THIS PLAN SHEET.

TO ACCOMPANY PLANS DATED _____

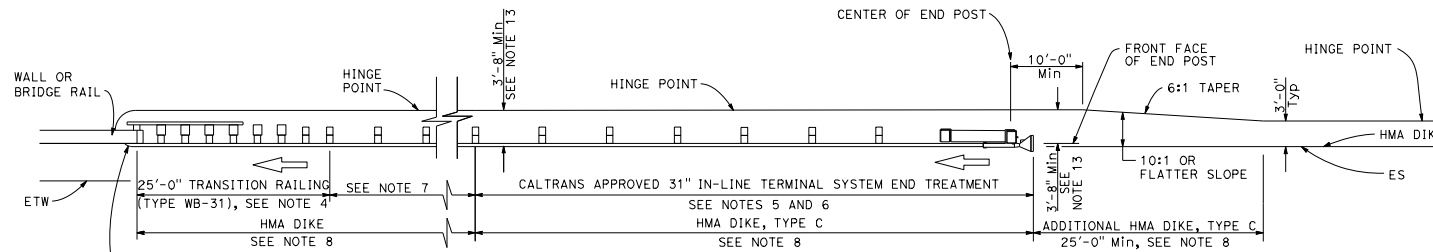

TYPE 12A LAYOUT

(MGS installation at structure approach with 31" in-line end treatment at traffic approach end of railing)
See Note 9

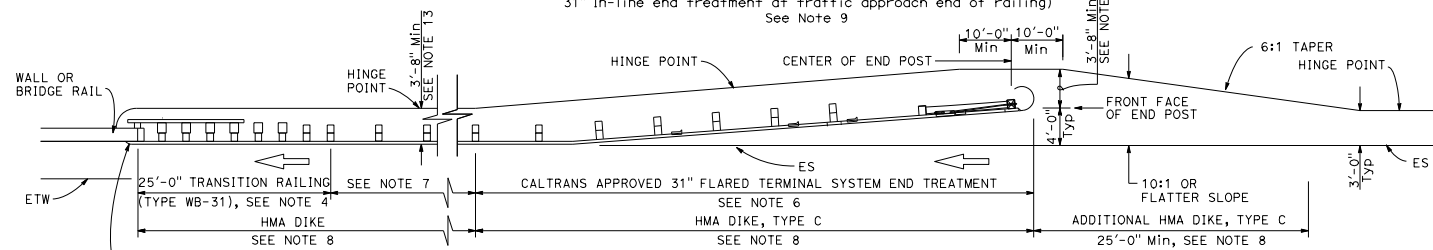

TYPE 12B LAYOUT

(MGS installation at structure approach with 31" flared end treatment at traffic approach end of railing)
See Note 9

NOTES:

- Line post, blocks and hardware to be used are shown on Revised Standard Plans RSP A77L1, RSP A77L2, RSP A77N1, RSP A77N2 and Standard Plan A77M1.
- MGS post spacing to be 6'-3" center to center, except as otherwise noted.
- Except as noted, line posts are 6" x 8" x 6'-0" wood with 6" x 8" x 1'-2" wood blocks. W6 x 8.5 or W6 x 9 steel posts, 6'-0" in length, with 6" x 8" x 1'-2" notched wood blocks or plastic blocks may be used for 6" x 8" x 6'-0" wood posts with 6" x 8" x 1'-2" wood blocks where applicable and when specified.
- For Transition Railing (Type WB-31) details for Types 12A and 12B Layouts, see Standard Plan A77U4.
- 31" in-line terminal system end treatments are used where site conditions will not accommodate a 31" flared end treatment.
- The type of 31" terminal system end treatment to be used will be shown on the Project Plans.
- Dependent on site conditions (embankment height, side slopes, or other fixed objects), it may be advisable to construct additional guard railing (a length equal to multiples of 12'-6" with 6'-3" post spacing) between the transition railing and end treatment. A 12.5 degree angle of departure can be drawn on the Project Plans from the edge of traveled way through the outer most point of the fixed object to determine the additional length of railing needed.
- Where placement of dike is required with guard railing installations, see Standard Plan A77N4 for dike positioning details.
- Type 12A or Type 12B Layouts are typically used:
 - To the right of approaching traffic, at the end of a structure, on two-lane conventional highway where the roadbed width across the structure is less than 40 feet.
 - To the left of approaching traffic, at the end of a structure, on two-lane conventional highway where the roadbed width across the structure is less than 40 feet.
 - To the right of approaching traffic at the end of each structure on multilane freeways or expressways with separate adjacent or parallel bridges.
 - To the right of approaching traffic at the end of the structure on multilane freeways or expressways with decked median on the bridge.
- See Revised Standard Plan RSP A7703 for typical layout used left of approaching traffic at the ends of each structure on multilane freeways or expressways with separate adjacent or parallel bridges.
- For additional details of typical connections to bridge rail, see Connection Detail AA on Standard Plans A77U1 and A77U2 and Connection Detail FF on Standard Plans A77V1 and A77V2.
- For additional details of a typical connection to walls or abutments, see Standard Plan A77U3.
- Use this offset for 8" block. For 12" block, use 4'-0" Min offset.

STATE OF CALIFORNIA
DEPARTMENT OF TRANSPORTATION

**MIDWEST GUARDRAIL SYSTEM
TYPICAL LAYOUTS FOR
STRUCTURE APPROACH**

NO SCALE

RSP A7701 DATED JANUARY 20, 2017 SUPERSEDES STANDARD PLAN A7701
DATED OCTOBER 30, 2015 - PAGE 69 OF THE STANDARD PLANS BOOK DATED 2015.

REVISED STANDARD PLAN RSP A77Q1

2015 REVISED STANDARD PLAN RSP A77Q1

DIST	COUNTY	ROUTE	POST MILES TOTAL PROJECT	SHEET NO.	TOTAL SHEETS

Randell D. Hiatt
REGISTERED CIVIL ENGINEER

January 20, 2017
PLANS APPROVAL DATE

THE STATE OF CALIFORNIA OR ITS OFFICERS OR AGENTS SHALL NOT BE RESPONSIBLE FOR THE ACCURACY OR COMPLETENESS OF SCANNED COPIES OF THIS PLAN SHEET.

REGISTERED PROFESSIONAL ENGINEER
No. C50200
Exp. 6-30-17
CIVIL
STATE OF CALIFORNIA

TO ACCOMPANY PLANS DATED _____

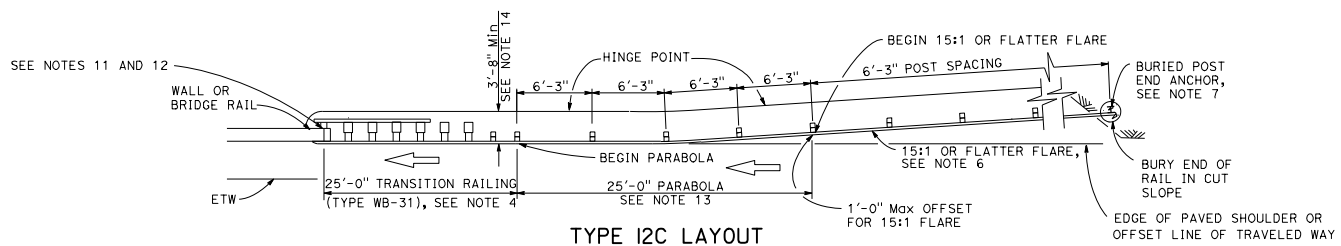

TYPE 12C LAYOUT

(MGS installation at structure approach with a Buried end anchor treatment at traffic approach end of railing)
See Notes 8 and 9

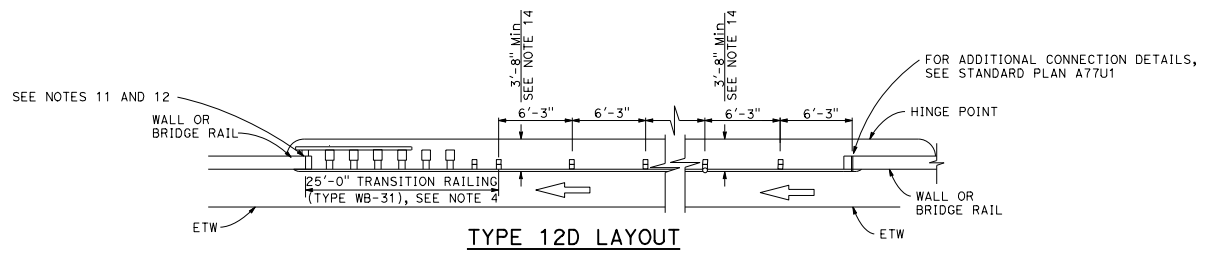

TYPE 12D LAYOUT

(Continuous MGS installation between structures)
See Notes 5 and 9

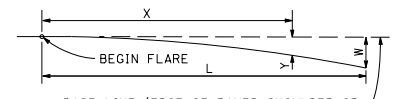

BASE LINE (EDGE OF PAVED SHOULDER OR OFFSET LINE OF EDGE OF TRAVELED WAY)

$$Y = \frac{WX^2}{L^2}$$

Y = OFFSET FROM BASE LINE
W = MAXIMUM OFFSET
X = DISTANCE ALONG BASE LINE
L = LENGTH OF FLARE

PARABOLIC FLARE OFFSETS

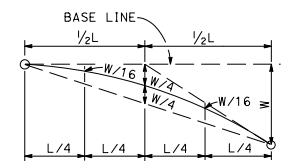

TYPICAL PARABOLIC LAYOUT

NOTES:

- Line post, blocks and hardware to be used are shown on Revised Standard Plans RSP A77L1, RSP A77L2, RSP A77N1, RSP A77N2 and Standard Plan A77M1.
- MGS post spacing to be 6'-3" center to center, except as otherwise noted.
- Except as noted, line posts are 6" x 8" x 6'-0" wood with 6" x 8" x 1'-2" wood blocks, W6 x 8.5 or W6 x 9 steel posts, 6'-0" in length, with 6" x 8" x 1'-2" notched wood blocks or plastic blocks may be used for 6" x 8" x 6'-0" wood posts with 6" x 8" x 1'-2" wood blocks where applicable and when specified.
- For Transition Railing (Type WB-31) details for Types 12C and 12D Layouts, see Standard Plan A77U4.
- Type 12D layout is typically used where continuous MGS is recommended between structures.
- The 15:1 or flatter flare for Type 12C Layout is based on the edge of the paved shoulder or offset line of edge of the traveled way. The length of MGS with the 15:1 or flatter flare is based on site conditions and should be a length equal to multiples of 12'-6".
- For details of the buried post end anchor used with Type 12C Layout, see Standard Plan A77T2.
- Where placement of dike is required with MGS installations, see Standard Plan A77N4 for dike positioning details.
- Type 12C Layout is typically used:
 - To the right of approaching traffic, at the end of the structure, on two-lane conventional highway where the roadbed width across the structure is less than 40 feet.
 - To the left of approaching traffic, at each of a structure, on two-lane conventional highway where the roadbed width across the structure is less than 40 feet.
 - To the right of approaching traffic at the end of each structure on multilane freeways or expressways with separate adjacent or parallel bridges.
 - To the right of approaching traffic at the end of the structure on multilane freeways or expressways with decked median on the bridge.
- See Revised Standard Plan RSP A7703 for typical layout used left of approaching traffic at the ends of each structure on multilane freeways or expressways with separate adjacent or parallel bridges.
- For additional details of typical connections to bridge rail, see Connection Detail AA on Standard Plans A77U1 and A77U2 and Connection Detail FF on Standard Plans A77V1 and A77V2.
- For additional details of a typical connection to walls or abutments, see Standard Plan A77U3.
- For typical flare offsets for 25'-0" length parabola with maximum offset of 1'-0", see Revised Standard Plan RSP A77P1.
- Use this offset for 8" block. For 12" block, use 4'-0" Min offset.

STATE OF CALIFORNIA
DEPARTMENT OF TRANSPORTATION

**MIDWEST GUARDRAIL SYSTEM
TYPICAL LAYOUTS FOR
STRUCTURE APPROACH
AND BETWEEN STRUCTURES**

NO SCALE

RSP A7702 DATED JANUARY 20, 2017 SUPERSEDES STANDARD PLAN A7702
DATED OCTOBER 30, 2015 - PAGE 70 OF THE STANDARD PLANS BOOK DATED 2015.
REVISED STANDARD PLAN RSP A77Q2

2015 REVISED STANDARD PLAN RSP A77Q2

DIST	COUNTY	ROUTE	POST MILES TOTAL PROJECT	SHEET TOTAL SHEETS

Randell D. Hiatt
REGISTERED CIVIL ENGINEER

January 20, 2017
PLANS APPROVAL DATE

REGISTERED PROFESSIONAL ENGINEER
Randell D. Hiatt
No. C50200
Exp. 6-30-17
CIVIL
STATE OF CALIFORNIA

THE STATE OF CALIFORNIA OR ITS OFFICERS OR AGENTS SHALL NOT BE RESPONSIBLE FOR THE ACCURACY OR COMPLETENESS OF SCANNED COPIES OF THIS PLAN SHEET.

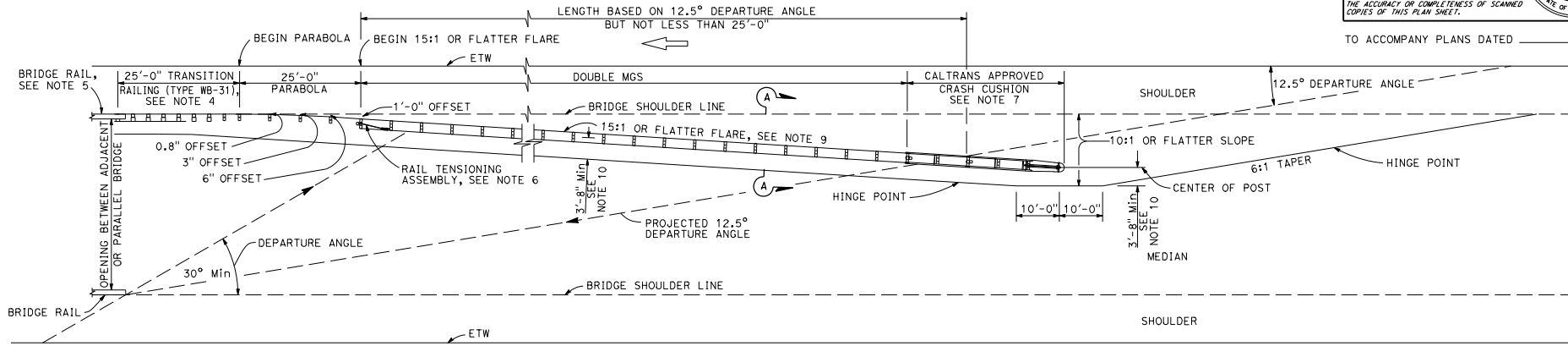

TYPE 12E LAYOUT

See Note 9

NOTES:

- Line post, blocks and hardware to be used are shown on Revised Standard Plans RSP A77L1, RSP A77L2, RSP A77N1, RSP A77N2, and Standard Plan A77M1.
- MGS post spacing to be 6'-3" center to center, except as otherwise noted.
- Except as noted, line posts are 6" x 8" x 6'-0" wood with 6" x 8" x 1'-2" wood blocks. W6 x 8.5 or W6 x 9 steel posts, 6'-0" in length, with 6" x 8" x 1'-2" notched wood blocks or notched recycled plastic blocks may be used for 6" x 8" x 6'-0" wood line posts with 6" x 8" x 1'-2" wood blocks where applicable and when specified.
- For Transition Railing (Type WB-31) details, see Standard Plan A77U4.
- For additional details of a typical connection to bridge rail, see Connection Detail AA on Standard Plan A77U1.
- For Rail Tensioning Assembly details, see Standard Plan A77S2.
- The type of Crash Cushion to be used will be shown on the Project Plans.
- Type 12E Layout is typically used left of approaching traffic at the end of each structure on multilane freeways or expressways where a median type barrier is not constructed between separated roadbeds.
- The 15:1 or flatter flare is measured off of the edge of traveled way.
- Use this offset for 8" block. For 12" block, use 4'-0" Min offset.

5/8" Ø BUTTON HEAD BOLT WITH Hex NUT OR 5/8" Ø ROD, THREADED BOTH ENDS, WITH Hex NUTS; 1/2" Max EXPOSED THREADS AFTER Hex NUT(S) TIGHTENED. NO WASHER ON RAIL FACES FOR BOLTED CONNECTION TO LINE POST

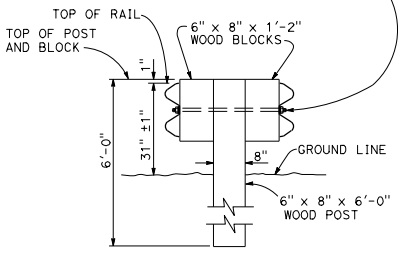

SECTION A-A

TYPICAL DOUBLE MIDWEST GUARDRAIL SYSTEM

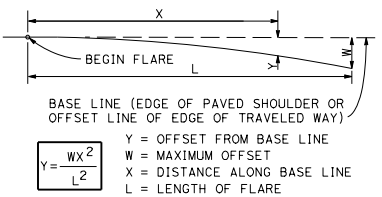

PARABOLIC FLARE OFFSETS

Y = OFFSET FROM BASE LINE
W = MAXIMUM OFFSET
X = DISTANCE ALONG BASE LINE
L = LENGTH OF FLARE

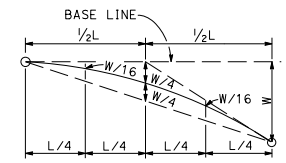

TYPICAL PARABOLIC LAYOUT

STATE OF CALIFORNIA
DEPARTMENT OF TRANSPORTATION
**MIDWEST GUARDRAIL SYSTEM
TYPICAL LAYOUTS FOR
STRUCTURE APPROACH**

NO SCALE

RSP A7703 DATED JANUARY 20, 2017 SUPERSEDES STANDARD PLAN A7703
DATED OCTOBER 30, 2015 - PAGE 71 OF THE STANDARD PLANS BOOK DATED 2015.
REVISED STANDARD PLAN RSP A77Q3

2015 REVISED STANDARD PLAN RSP A77Q3

DIST	COUNTY	ROUTE	POST MILES TOTAL PROJECT	SHEET NO.	TOTAL SHEETS

Randell D. Hiatt
 REGISTERED CIVIL ENGINEER
 No. C50200
 Exp. 6-30-17
 CIVIL
 STATE OF CALIFORNIA

January 20, 2017
 PLANS APPROVAL DATE
 THE STATE OF CALIFORNIA OR ITS OFFICERS OR AGENTS SHALL NOT BE RESPONSIBLE FOR THE ACCURACY OR COMPLETENESS OF SCANNED COPIES OF THIS PLAN SHEET.

TO ACCOMPANY PLANS DATED _____

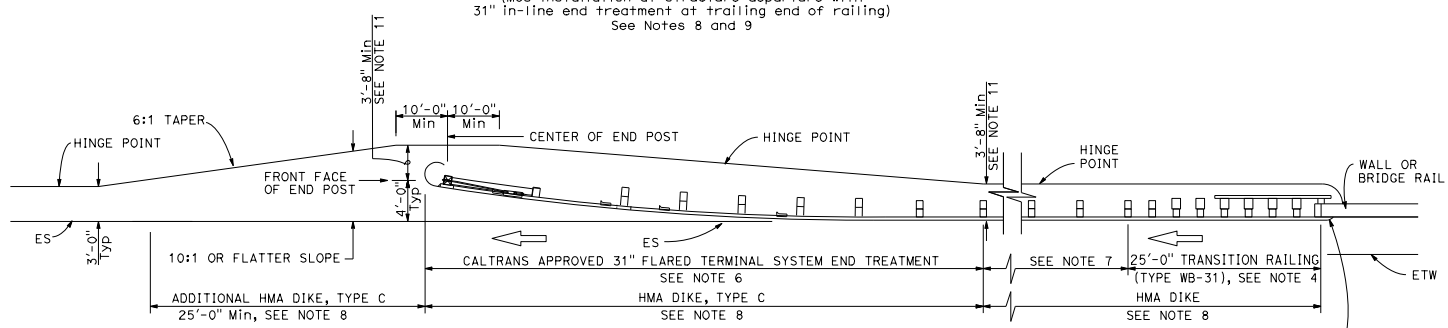
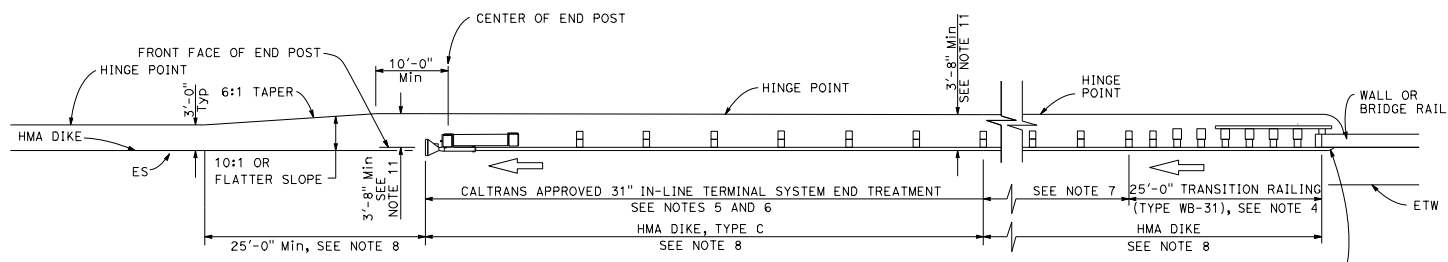

NOTES:

- Line post, blocks and hardware to be used are shown on Revised Standard Plans RSP A77L1, RSP A77L2, RSP A77N1, RSP A77N2 and Standard Plan A77M1.
- MGS post spacing to be 6'-3" center to center, except as otherwise noted.
- Except as noted, line posts are 6" x 8" x 6'-0" wood with 6" x 8" x 1'-2" wood blocks. W6 x 8.5 or W6 x 9 steel posts, 6'-0" in length, with 6" x 8" x 1'-2" notched wood blocks or notched recycled plastic blocks may be used for 6" x 8" x 6'-0" wood posts with 6" x 8" x 1'-2" wood blocks where applicable and when specified.
- For Transition Railing (Type WB-31) details for Types 12AA and 12BB Layouts, see Standard Plan A77U4.
- 31" in-line terminal system treatments are used where site conditions will not accommodate a 31" flared end treatment.
- The type of 31" terminal system to be used will be shown on the Project Plans.
- Dependent on site conditions (embankment height, side slopes, other fixed objects), it may be advisable to construct additional MGS (a length equal to multiples of 12'-6" with 6'-3" post spacing) between the transition railing and 31" end treatments.
- Where placement of dike is required with MGS installations, see Standard Plan A77N4 for dike positioning details.
- Type 12AA or Type 12BB Layouts are typically used to the right of traffic departing a structure on two-way conventional highways where the roadbed width across the structure is less than 40 feet.
- For additional details of typical connections to bridge rail, see Connection Detail CC on Standard Plan A77U2 and Connection Detail HH on Standard Plan A77V2.
- Use this offset for 8" block. For 12" block, use 4'-0" Min offset.

STATE OF CALIFORNIA
 DEPARTMENT OF TRANSPORTATION
**MIDWEST GUARDRAIL SYSTEM
 TYPICAL LAYOUTS FOR
 STRUCTURE DEPARTURE**

NO SCALE

RSP A7704 DATED JANUARY 20, 2017 SUPERSEDES STANDARD PLAN A7704
 DATED OCTOBER 30, 2015 - PAGE 72 OF THE STANDARD PLANS BOOK DATED 2015.
REVISED STANDARD PLAN RSP A77Q4

NOTES:

- Line post, blocks and hardware to be used are shown on Revised Standard Plans RSP A77L1, RSP A77L2, RSP A77N1, RSP A77N2 and Standard Plan A77M1.
- MGS post spacing to be 6'-3" center to center, except as otherwise noted.
- Except as noted, line posts are 6" x 8" x 6'-0" wood with 6" x 8" x 1'-2" wood blocks. W6 x 8.5 or W6 x 9 steel posts, 6'-0" in length, with 6" x 8" x 1'-2" notched wood blocks or notched recycled plastic blocks may be used for 6" x 8" x 6'-0" wood line posts with 6" x 8" x 1'-2" wood blocks where applicable and when specified.
- A 4'-0" minimum clearance is required between the face of the railing and the face of a fixed object located directly behind MGS sections with post spacing of 6'-3". Construct MGS as shown in the detail "Strengthened Midwest Guardrail System Sections for Fixed Object" on this plan, where the clearance between the face of the railing and the face of a fixed object is less than 4'-0", but not less than 3'-0". Where the clearance is less than 3'-0", a concrete wall or barrier should be constructed to shield the fixed object(s).
- For End Anchor Assembly (Type SFT) details, see Standard Plan A77S1.
- For details of Rail Tensioning Assembly, see Standard Plan A77S2.
- The type of crash cushion to be used will be shown on the Project Plans.
- Type 14A layout is typically used on multilane freeways or expressways to shield fixed objects where a median type barrier is not constructed between the separated roadbeds.
- For typical flare offsets for 25'-0" length parabola with maximum offset of 1'-0", see Revised Standard Plan RSP A77P1.
- The 15:1 or flatter flare is measured off of the edge of traveled way.
- W6 x 15 steel post, 8'-0" in length, with 8" x 8" x 1'-2" notched wood block or notched recycled plastic block may be used in place of the 10" x 10" x 8'-0" wood post with 8" x 8" x 1'-2" wood block shown in the detail "Strengthened Midwest Guardrail System Sections for Fixed Object".
- Use this offset for 8" block. For 12" block use minimum 4'-0" offset.

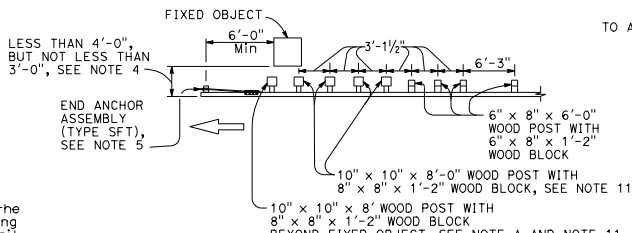

NOTE A: For a series of fixed objects (bridge columns, overhead line supports, etc.) additional 10" x 10" x 8'-0" wood post with 8" x 8" x 1'-2" wood blocks at 3'-1/2" center to center spacing are to be used between fixed objects.

**STRENGTHENED MIDWEST GUARDRAIL SYSTEM
SECTIONS FOR FIXED OBJECT**

Use strengthened MGS sections with Type 14A layout where minimum clearance between the face of the railing and fixed object(s) is less than 4'-0", but not less than 3'-0", See Note 4.

TO ACCOMPANY PLANS DATED _____

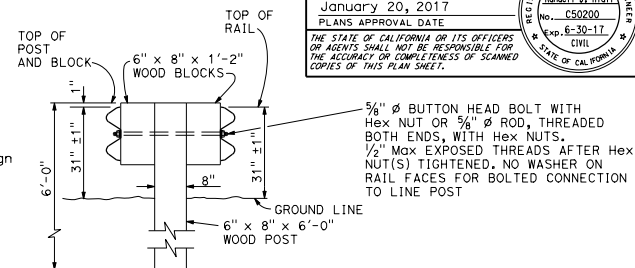

**SECTION A-A
TYPICAL DOUBLE MIDWEST
GUARDRAIL SYSTEM**

DIST	COUNTY	ROUTE	POST MILES TOTAL PROJECT	SHEET TOTAL SHEETS

Randell D. Hiatt
REGISTERED CIVIL ENGINEER

January 20, 2017
PLANS APPROVAL DATE

THE STATE OF CALIFORNIA OR ITS OFFICERS OR AGENTS SHALL NOT BE RESPONSIBLE FOR THE ACCURACY OR COMPLETENESS OF SCANNED COPIES OF THIS PLAN SHEET.

REGISTERED PROFESSIONAL ENGINEER
No. C50200
Exp. 6-30-17
CIVIL
STATE OF CALIFORNIA

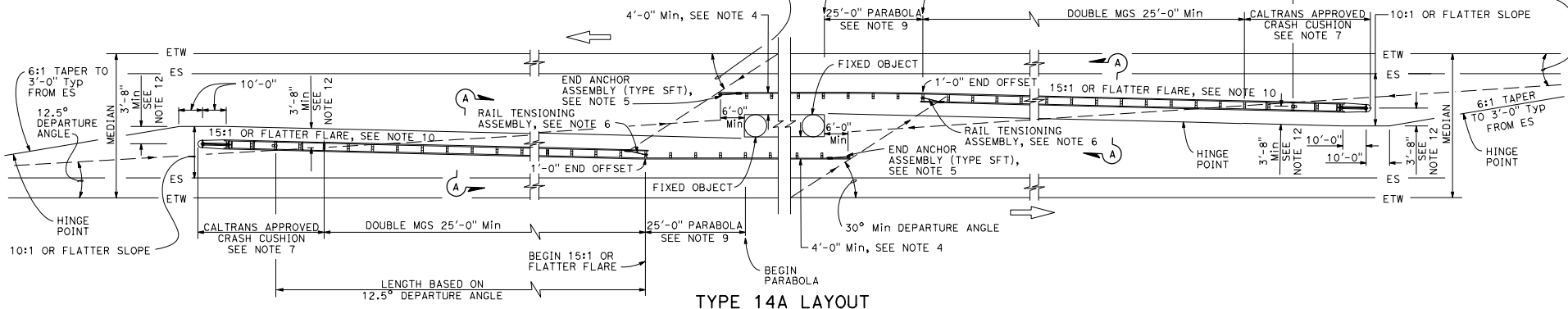

TYPE 14A LAYOUT

See Note 8

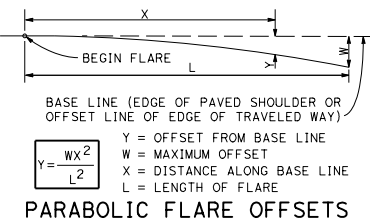

PARABOLIC FLARE OFFSETS

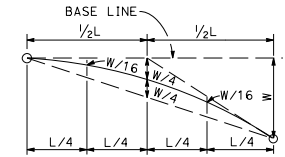

TYPICAL PARABOLIC LAYOUT

STATE OF CALIFORNIA
DEPARTMENT OF TRANSPORTATION

**MIDWEST GUARDRAIL SYSTEM
TYPICAL LAYOUTS FOR
FIXED OBJECTS
BETWEEN SEPARATE ROADBEDS
(TWO-WAY TRAFFIC)**

NO SCALE

RSP A77R1 DATED JANUARY 20, 2017 SUPERSEDES STANDARD PLAN A77R1
DATED OCTOBER 30, 2015 - PAGE 74 OF THE STANDARD PLANS BOOK DATED 2015.

REVISED STANDARD PLAN RSP A77R1

2015 REVISED STANDARD PLAN RSP A77R1

NOTES:

- Line post, blocks and hardware to be used are shown on Revised Standard Plans RSP A77L1, RSP A77L2, RSP A77N1, RSP A77N2 and Standard Plan A77M1.
- MGS post spacing to be 6'-3" center to center, except as otherwise noted.
- Except as noted, line posts are 6" x 8" x 6'-0" wood with 6" x 8" x 1'-2" wood blocks. W6 x 8.5 or W6 x 9 steel posts, 6'-0" in length, with 6" x 8" x 1'-2" notched wood blocks or notched recycled plastic blocks may be used for 6" x 8" x 6'-0" wood line posts with 6" x 8" x 1'-2" wood blocks where applicable and when specified.
- A 4'-0" minimum clearance is required between the face of the railing and the face of a fixed object located directly behind MGS section with post spacing of 6'-3". Construct MGS as shown in the detail "Strengthened Midwest Guardrail System Sections for Fixed Object" on this plan, where the clearance between the face of the railing and the face of a fixed object is less than 4'-0", but not less than 3'-0". Where the clearance is less than 3'-0", a concrete wall or barrier should be constructed to shield the fixed object(s).

- For End Anchor Assembly (Type SFT) details, see Standard Plan A77S1.
- Type of crash cushion to be used will be shown on the Project Plans.
- Type 15A layout is typically used on multilane freeways or expressways to shield fixed objects in the area between separated one-way roadbeds.
- For typical flare offsets for 25'-0" length parabola with maximum offset of 1'-0", see Revised Standard Plan RSP A77P1.
- The 15:1 or flatter flare is measured off of the edge of the traveled way.
- W6 x 15 steel post, 8'-0" in length, with 8" x 8" x 1'-2" notched wood block or notched recycled plastic blocks may be used in place of the 10" x 10" x 8'-0" wood post with 8" x 8" x 1'-2" wood block shown in the detail "Strengthened Midwest Guardrail System Sections for Fixed Object".

DIST	COUNTY	ROUTE	POST MILES TOTAL PROJECT	SHEET TOTAL SHEETS

Randell D. Hiatt
REGISTERED CIVIL ENGINEER
No. C50200
Exp. 6-30-17
CIVIL
STATE OF CALIFORNIA

January 20, 2017
PLANS APPROVAL DATE

THE STATE OF CALIFORNIA OR ITS OFFICERS OR AGENTS SHALL NOT BE RESPONSIBLE FOR THE ACCURACY OR COMPLETENESS OF SCANNED COPIES OF THIS PLAN SHEET.

TO ACCOMPANY PLANS DATED _____

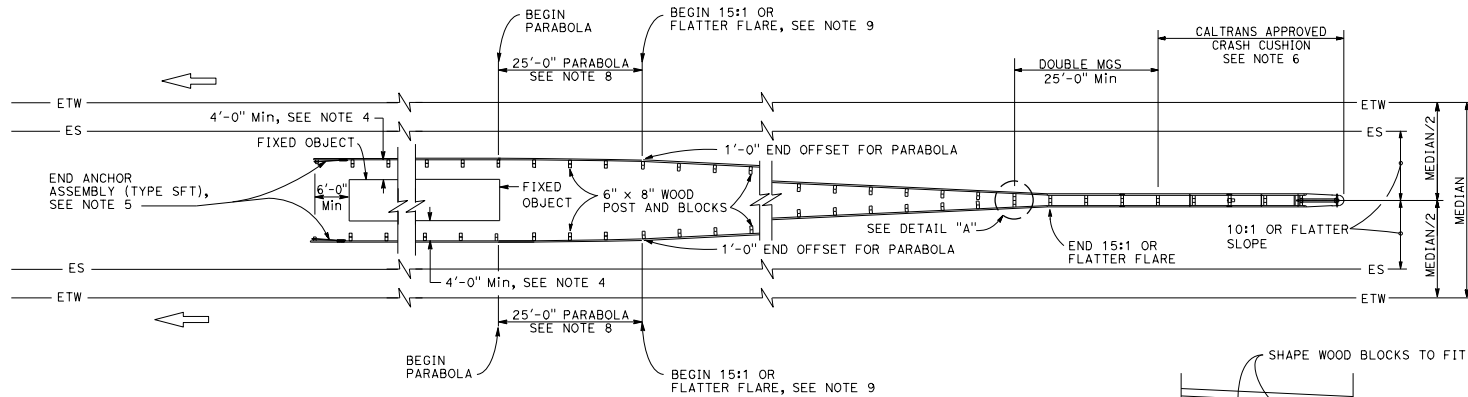

TYPE 15A LAYOUT

See Note 7

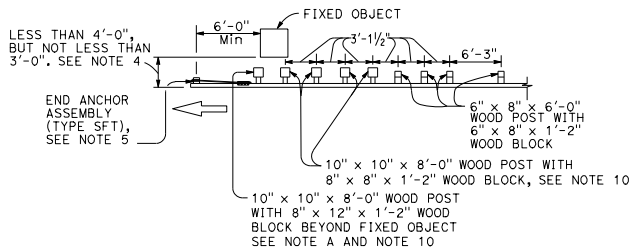

STRENGTHENED MIDWEST GUARDRAIL SYSTEM SECTIONS FOR FIXED OBJECT

Use strengthened MGS sections with Type 15A layout where minimum clearance between the face of the MGS and the fixed object(s) is less than 4'-0", but not less than 3'-0". See Note 4.

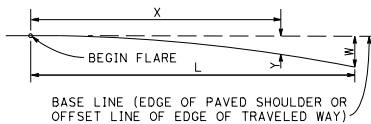

PARABOLIC FLARE OFFSETS

Y = OFFSET FROM BASE LINE
W = MAXIMUM OFFSET
X = DISTANCE ALONG BASE LINE
L = LENGTH OF FLARE

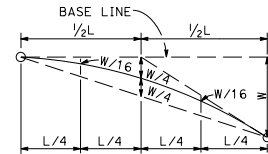

TYPICAL PARABOLIC LAYOUT

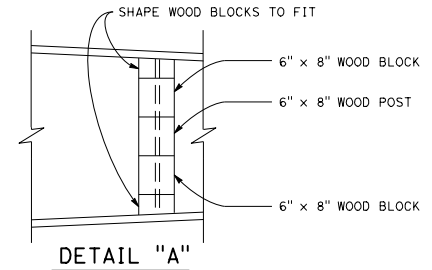

DETAIL "A"

STATE OF CALIFORNIA
DEPARTMENT OF TRANSPORTATION

MIDWEST GUARDRAIL SYSTEM TYPICAL LAYOUTS FOR FIXED OBJECTS BETWEEN SEPARATE ROADBEDS (ONE-WAY TRAFFIC)

NO SCALE

RSP A77R2 DATED JANUARY 20, 2017 SUPERSEDES STANDARD PLAN A77R2
DATED OCTOBER 30, 2015 - PAGE 75 OF THE STANDARD PLANS BOOK DATED 2015.

REVISED STANDARD PLAN RSP A77R2

2015 REVISED STANDARD PLAN RSP A77R2

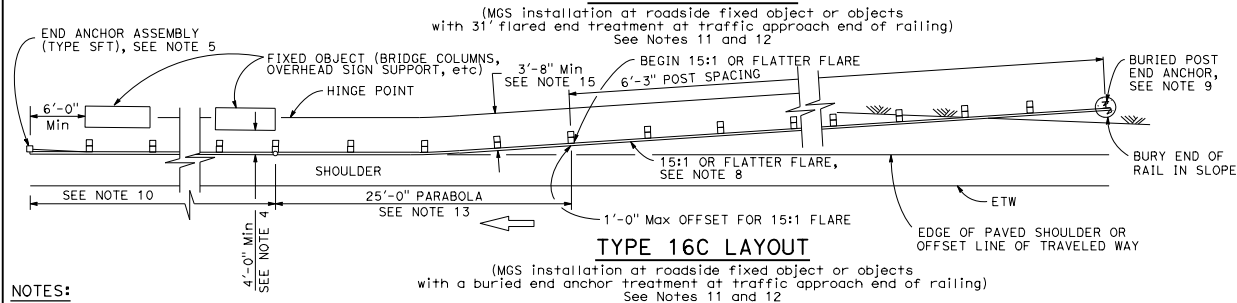
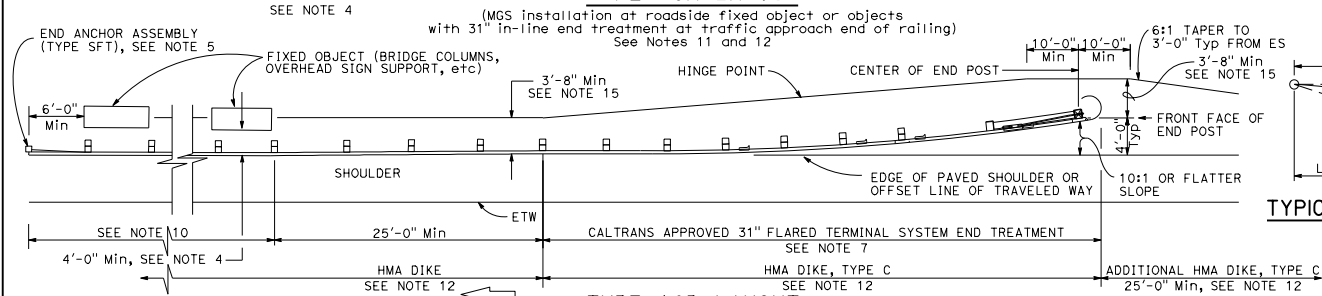
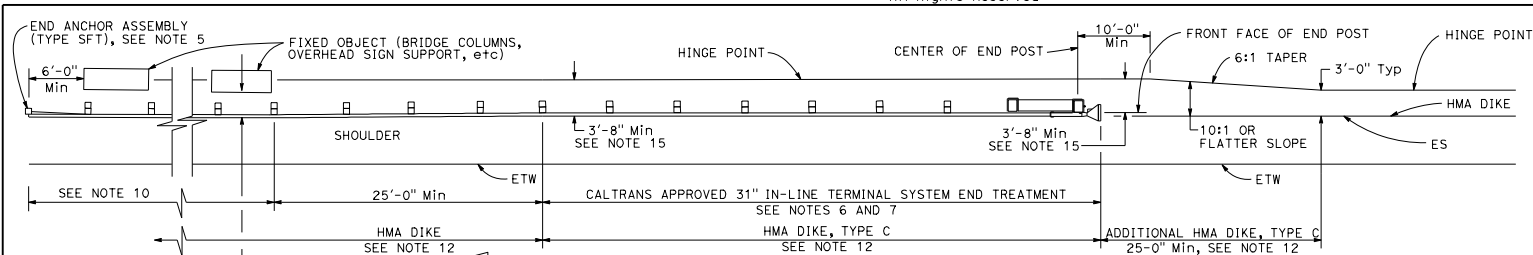

NOTES:

- Line post, blocks and hardware to be used are shown on Revised Standard Plans RSP A77L1, RSP A77L2, RSP A77N1, RSP A77N2 and Standard Plan A77M1.
- MGS post spacing to be 6'-3" center to center, except as otherwise noted.
- Except as noted, line posts are 6" x 8" x 6'-0" wood with 6" x 8" x 1'-2" wood blocks, W6 x 8.5 or W6 x 9 steel posts, 6'-0" in length, with 6" x 8" x 1'-2" notched wood blocks or notched recycled plastic blocks may be used for 6" x 8" x 6'-0" wood line posts with 6" x 8" x 1'-2" wood blocks where applicable and when specified.
- A 4'-0" minimum clearance is required between the face of the railing and the face of a fixed object located directly behind MGS sections with post spacing of 6'-3". Construct MGS as shown in the detail "Strengthened Midwest Guardrail System Sections for Fixed Object" on this plan, where the clearance between the face of the railing and the face of a fixed object is less than 4'-0", but not less than 3'-0". Where the clearance is less than 3'-0", a concrete wall or barrier should be constructed to shield the fixed object(s).
- For End Anchor Assembly (Type SFT) details, see Standard Plan A77S1.
- 31" in-line terminal system end treatments are used where site conditions will not accommodate a 31" flared end treatment.
- The type of 31" terminal system to be used will be shown on the Project Plans.
- The 15:1 or flatter flare used with Type 16C Layout is based on the edge of the paved shoulder or offset line of edge of the traveled way. The length of MGS within the 15:1 or flatter flare is based on site conditions and should be a length equal to multiples of 12'-6".
- For details of the Buried Post End Anchor used with Type 16C Layout, see Standard Plan A77T2.
- As site conditions dictate, construct additional MGS to shield fixed object(s). Additional MGS length equal to multiples of 12'-6". Post spacing at 6'-3" except as specified in Note 4.
- Layout Types 16A, 16B or 16C are typically used where MGS is recommended to shield roadside fixed object(s) and a crashworthy 31" end treatment is required for only one direction of traffic.
- Where placement of dike is required with MGS, see Standard Plan A77N4 for dike positioning details.
- For typical flare offsets for 25'-0" length parabola with maximum offset of 1'-0", see Revised Standard Plan RSP A77P1.
- W6 x 15 steel post, 8'-0" in length, with 8" x 8" x 1'-2" notched wood block or notched recycled plastic blocks may be used in place of the 10" x 10" x 8'-0" wood post with 8" x 8" x 1'-2" wood block shown in the detail "Strengthened Midwest Guardrail System Sections for Fixed Object".
- Use this offset for 8" block. For 12" block use minimum 4'-0" offset.

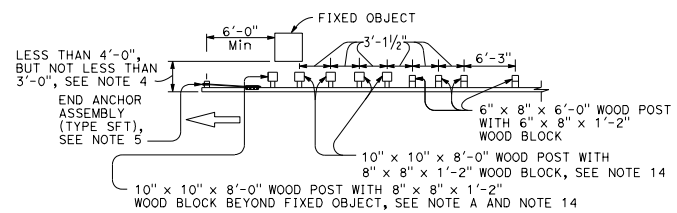
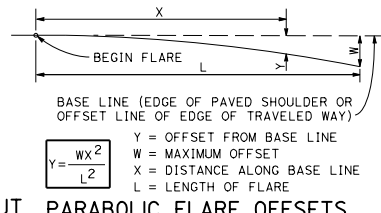
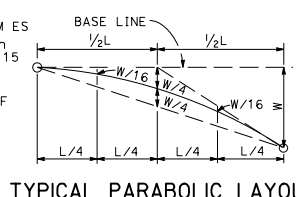

STRENGTHENED MIDWEST GUARDRAIL SYSTEM SECTIONS FOR FIXED OBJECT

Use strengthened MGS sections with Types 16A, 16B or 16C layouts where minimum clearance between the face of the railing and fixed object(s) is less than 4'-0", but not less than 3'-0". See Note 4

MIDWEST GUARDRAIL SYSTEM TYPICAL LAYOUTS FOR ROADSIDE FIXED OBJECTS

NO SCALE

RSP A77R3 DATED JANUARY 20, 2017 SUPERSEDES STANDARD PLAN A77R3 DATED OCTOBER 30, 2015 - PAGE 76 OF THE STANDARD PLANS BOOK DATED 2015.

REVISED STANDARD PLAN RSP A77R3

DIST	COUNTY	ROUTE	POST MILES TOTAL PROJECT	SHEET NO.	TOTAL SHEETS

Randell D. Hiatt
REGISTERED CIVIL ENGINEER

January 20, 2017
PLANS APPROVAL DATE

PLANS APPROVAL NO. CS0200
APPROVAL DATE EXP. 6-30-17
CIVIL

THE STATE OF CALIFORNIA OR ITS OFFICERS OR AGENTS SHALL NOT BE RESPONSIBLE FOR THE ACCURACY OR COMPLETENESS OF SCANNED COPIES OF THIS PLAN SHEET.

2015 REVISED STANDARD PLAN RSP A77R3

DIST	COUNTY	ROUTE	POST MILES TOTAL PROJECT	SHEET NO.	TOTAL SHEETS

Randell D. Hiatt
REGISTERED CIVIL ENGINEER

January 20, 2017
PLANS APPROVAL DATE

THE STATE OF CALIFORNIA OR ITS OFFICERS OR AGENTS SHALL NOT BE RESPONSIBLE FOR THE ACCURACY OR COMPLETENESS OF SCANNED COPIES OF THIS PLAN SHEET.

REGISTERED PROFESSIONAL ENGINEER
Randell D. Hiatt
No. CS0200
Exp. 6-30-17
CIVIL
STATE OF CALIFORNIA

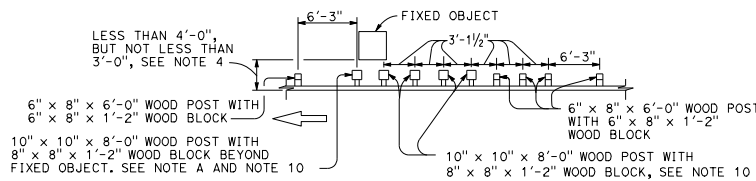

NOTE A: For a series of fixed objects (bridge columns, overhead sign supports, etc.) additional 10" x 10" x 8'-0" wood post with 8" x 8" x 1'-2" wood blocks at 3'-1/2" center to center spacing are to be used between fixed object(s).

**STRENGTHENED MIDWEST GUARDRAIL SYSTEM SECTIONS
FOR FIXED OBJECT**

Use strengthened MGS sections with layout Types 16D or 16E where minimum clearance between the face of the MGS and fixed object(s) is less than 4'-0", but not less than 3'-0". See Note 4.

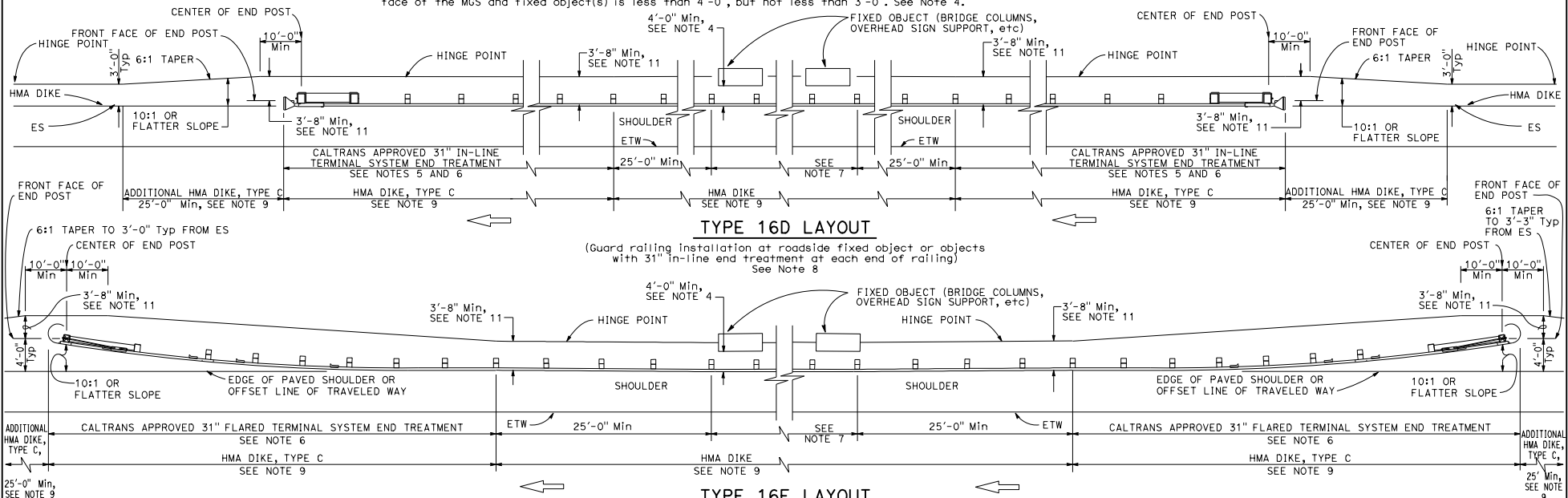

- NOTES:**
- Line post, blocks and hardware to be used are shown on Revised Standard Plans RSP A77L1, RSP A77L2, RSP A77N1, RSP A77N2 and Standard Plan A77M1.
 - MGS post spacing to be 6'-3" center to center, except as otherwise noted.
 - Except as noted, line posts are 6" x 8" x 6'-0" wood with 6" x 8" x 1'-2" wood blocks. W6 x 8.5 or W6 x 9 steel posts, 6'-0" in length, with 6" x 8" x 1'-2" notched wood blocks or notched recycled plastic blocks may be used for 6" x 8" x 6'-0" wood line posts with 6" x 8" x 1'-2" wood blocks where applicable and when specified.
 - A 4'-0" minimum clearance is required between the face of the railing and the face of a fixed object located directly behind MGS sections with post spacing at 6'-3". Construct MGS as shown in the detail "Strengthened Midwest Guardrail System Sections for Fixed Object", on this plan, where the clearance between the face of the railing and the face of a fixed object is less than 4'-0", but not less than 3'-0". Where the clearance is less than 3'-0", a concrete wall or barrier should be constructed to shield the fixed object(s).
 - 31" in-line terminal system end treatments are used where site conditions will not accommodate a 31" flared end treatment.
 - The type of 31" terminal system to be used will be shown on the Project Plans.
 - As site conditions dictate, construct additional MGS to shield fixed object(s). Additional MGS length equal to multiples of 12'-6". Post spacing at 6'-3", except as specified in Note 4.
 - Layout Types 16D through 16L, shown on the A77R Series of Standard Plans, are typically used where MGS is recommended to shield roadside fixed object(s) and a crashworthy 31" end treatment is required for both directions of traffic.
 - Where placement of dike is required with MGS, see Standard Plan A77N4 for dike positioning details.
 - W6 x 15 steel post, 8'-0" in length, with 8" x 8" x 1'-2" notched wood block or notched recycled plastic block may be used in place of the 10" x 10" x 8'-0" wood post with 8" x 8" x 1'-2" wood block shown in the detail "Strengthened Midwest Guardrail System Sections for Fixed Object".
 - Use this offset for 8" block. For 12" block use minimum 4'-0" offset.

STATE OF CALIFORNIA
DEPARTMENT OF TRANSPORTATION

**MIDWEST GUARDRAIL SYSTEM
TYPICAL LAYOUTS FOR
ROADSIDE FIXED OBJECTS**

NO SCALE
RSP A77R4 DATED JANUARY 20, 2017 SUPERSEDES STANDARD PLAN A77R4
DATED OCTOBER 30, 2015 - PAGE 77 OF THE STANDARD PLANS BOOK DATED 2015.

REVISED STANDARD PLAN RSP A77R4

2015 REVISED STANDARD PLAN RSP A77R4

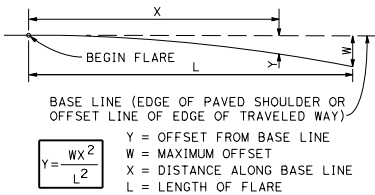

PARABOLIC FLARE OFFSETS

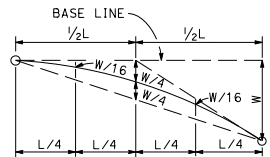

TYPICAL PARABOLIC LAYOUT

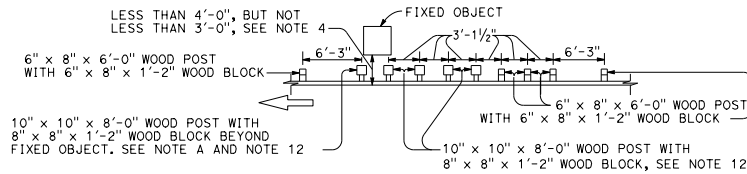

NOTE A: For a series of fixed objects (bridge columns, overhead sign supports, etc) additional 10" x 10" x 8'-0" wood post with 8" x 8" x 1'-2" wood blocks at 3'-1 1/2" center to center spacing are to be used between fixed object(s).

STRENGTHENED MIDWEST GUARDRAIL SYSTEM SECTIONS FOR FIXED OBJECT

Use strengthened MGS sections with layout Types 16F or 16G where minimum clearance between the face of the MGS and fixed object(s) is less than 4'-0", but not less than 3'-0". See Note 4.

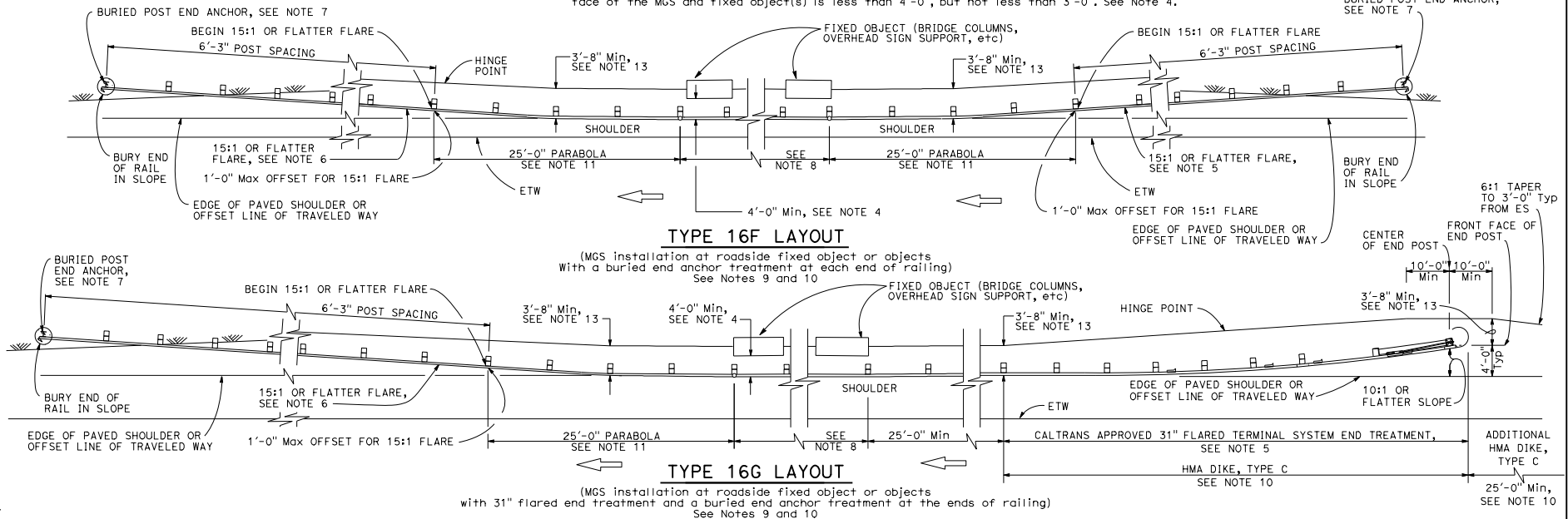

NOTES:

- Line post, blocks and hardware to be used are shown on Revised Standard Plans RSP A77L1, RSP A77L2, RSP A77N1, RSP A77N2 and Standard Plan A77M1.
- MGS post spacing to be 6'-3" center to center, except as otherwise noted.
- Except as noted, line posts are 6" x 8" x 6'-0" wood with 6" x 8" x 1'-2" wood blocks. W6 x 8.5 or W6 x 9 steel posts, 6'-0" in length, with 8" x 8" x 1'-2" notched wood blocks or notched recycled plastic blocks may be used for 6" x 8" x 6'-0" wood posts with 6" x 8" x 1'-2" wood blocks where applicable and when specified.
- A 4'-0" minimum clearance is required between the face of the railing and the face of a fixed object located directly behind MGS sections with post spacing at 6'-3". Construct MGS as shown in the detail "Strengthened Midwest Guardrail System Sections for Fixed Objects" on this plan, where the clearance between the face of the railing and the face of a fixed object is less than 4'-0", but not less than 3'-0". Where the clearance is less than 3'-0", a concrete wall or barrier should be constructed to shield the fixed object(s).
- The type of 31" terminal system to be used will be shown on the Project Plans.
- The 15:1 or flatter flare for the buried post anchor is based on the edge of the paved shoulder or offset line of edge of the traveled way. The length of MGS within the 15:1 or flatter flare is based on site conditions and should be a length equal to multiples of 12'-6".
- For details of the Buried Post End Anchor, see Standard Plan A77T2.
- As site conditions dictate, construct additional MGS to shield fixed object(s). Additional MGS length equal to multiples of 12'-6". Post spacing at 6'-3", except as specified in Note 4.
- Layout Types 16D through 16L, shown on the A77R Series of Standard Plans, are typically used on highways where MGS is recommended to shield roadside fixed object(s) and a crashworthy 31" end treatment is required for both directions of traffic.
- Where placement of dike is required with MGS, see Standard Plan A77N4 for dike positioning details.
- For typical flare offsets for 25'-0" length parabola with maximum offset of 1'-0", see Revised Standard Plan RSP A77P1.
- W6 x 15 steel post, 8'-0" in length, with 8" x 8" x 1'-2" notched wood block or notched recycled plastic blocks may be used in place of the 10" x 10" x 8'-0" wood post with 8" x 8" x 1'-2" wood block shown in the detail "Strengthened Midwest Guardrail System Sections for Fixed Object".
- Use this offset for 8" block. For 12" block use minimum 4'-0" offset.

STATE OF CALIFORNIA
DEPARTMENT OF TRANSPORTATION

**MIDWEST GUARDRAIL SYSTEM
TYPICAL LAYOUTS FOR
ROADSIDE FIXED OBJECTS**

NO SCALE
RSP A77R5 DATED JANUARY 20, 2017 SUPERSEDES STANDARD PLAN A77R5
DATED OCTOBER 30, 2015 - PAGE 78 OF THE STANDARD PLANS BOOK DATED 2015.

REVISED STANDARD PLAN RSP A77R5

DIST	COUNTY	ROUTE	POST MILES TOTAL PROJECT	SHEET NO.	TOTAL SHEETS

Randell D. Hiatt
 REGISTERED CIVIL ENGINEER
 January 20, 2017
 PLANS APPROVAL DATE
 THE STATE OF CALIFORNIA OR ITS OFFICERS OR AGENTS SHALL NOT BE RESPONSIBLE FOR THE ACCURACY OR COMPLETENESS OF SCANNED COPIES OF THIS PLAN SHEET.

TO ACCOMPANY PLANS DATED _____

2015 REVISED STANDARD PLAN RSP A77R5

DIST	COUNTY	ROUTE	POST MILES TOTAL PROJECT	SHEET NO.	TOTAL SHEETS

Randell D. Hiatt
REGISTERED CIVIL ENGINEER

January 20, 2017
PLANS APPROVAL DATE

THE STATE OF CALIFORNIA OR ITS OFFICERS OR AGENTS SHALL NOT BE RESPONSIBLE FOR THE ACCURACY OR COMPLETENESS OF SCANNED COPIES OF THIS PLAN SHEET.

NO. C50200
EXP. 6-30-17
CIVIL
STATE OF CALIFORNIA

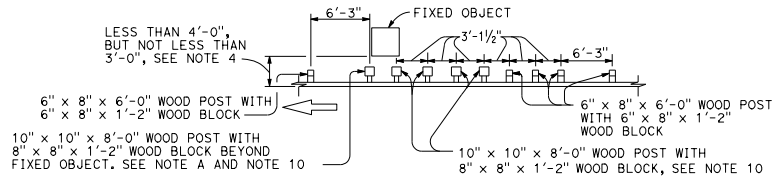

NOTE A: For a series of fixed objects (bridge columns, overhead sign supports, etc.) additional 10' x 10' x 8'-0" wood post with 8' x 8' x 1'-2" wood blocks at 3'-1/2" center to center spacing are to be used between fixed object(s).

STRENGTHENED MIDWEST GUARDRAIL SYSTEM SECTIONS FOR FIXED OBJECT

Use strengthened MGS sections with layout Type 16H where minimum clearance between the face of the MGS and fixed object(s) is less than 4'-0", but not less than 3'-0". See Note 4.

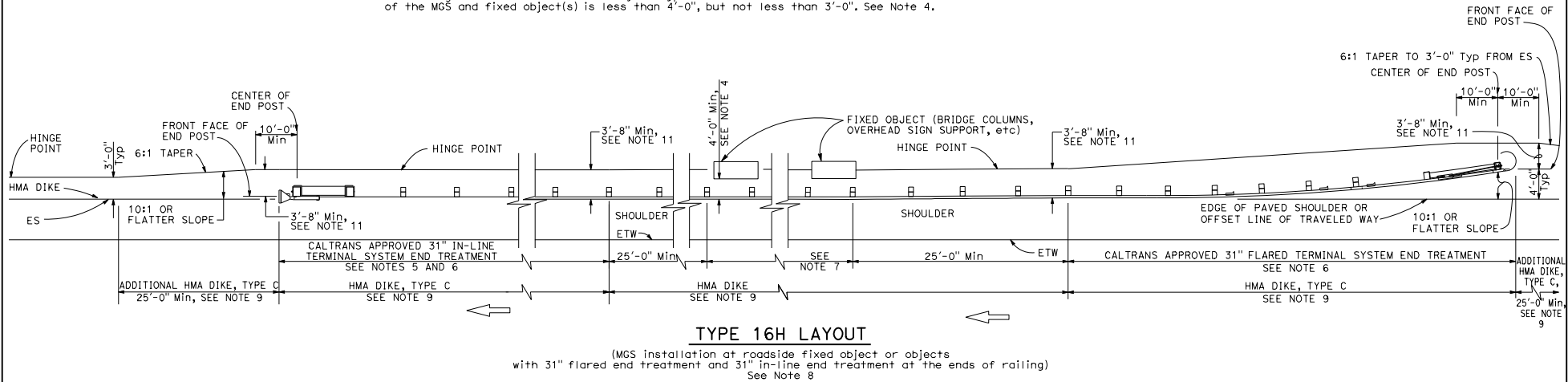

TYPE 16H LAYOUT

(MGS installation at roadside fixed object or objects with 31" flared end treatment and 31" in-line end treatment at the ends of railing)
See Note 8

NOTES:

- Line post, blocks and hardware to be used are shown on Revised Standard Plans RSP A77L1, RSP A77L2, RSP A77N1, RSP A77N2 and Standard Plan A77M1.
- MGS post spacing to be 6'-3" center to center, except as otherwise noted.
- Except as noted, line posts are 6" x 8" x 6'-0" wood with 6" x 8" x 1'-2" wood blocks, W6 x 8.5 or W6 x 9 steel posts, 6'-0" in length, with 6" x 8" x 1'-2" notched wood blocks or notched recycled plastic blocks may be used for 6" x 8" x 6'-0" wood posts with 6" x 8" x 1'-2" wood blocks where applicable and when specified.
- A 4'-0" minimum clearance is required between the face of the railing and the face of a fixed object located directly behind MGS sections with post spacing at 6'-3". Construct MGS as shown in the detail "Strengthened Midwest Guardrail System Sections for Fixed Objects" on this plan, where the clearance between the face of the railing and the face of a fixed object is less than 4'-0", but not less than 3'-0". Where the clearance is less than 3'-0", a concrete wall or barrier should be constructed to shield the fixed object(s).
- 31" in-line terminal system end treatments are used where site conditions will not accommodate a 31" flared end treatment.
- The type of 31" terminal system to be used will be shown on the Project Plans.
- As site conditions dictate, construct additional MGS to shield fixed object(s). Additional MGS length equal to multiples of 12'-6". Post spacing at 6'-3", except as specified in Note 4.
- Layout Types 16D through 16L, shown on the A77R Series of Standard Plans, typically used where MGS is recommended to shield roadside fixed object(s) and a crashworthy 31" end treatment is required for both directions of traffic.
- Where placement of dike is required with MGS, see Standard Plan A77N4 for dike positioning details.
- W6 x 15 steel post, 8'-0" in length, with 8" x 8" x 1'-2" notched wood block or notched recycled plastic blocks may be used in place of the 10" x 10" x 8'-0" wood post with 8" x 8" x 1'-2" wood block shown in the detail "Strengthened Midwest Guardrail System Sections for Fixed Object".
- Use this offset for 8" block. For 12" block use minimum 4'-0" offset.

STATE OF CALIFORNIA
DEPARTMENT OF TRANSPORTATION

MIDWEST GUARDRAIL SYSTEM TYPICAL LAYOUTS FOR ROADSIDE FIXED OBJECTS

NO SCALE

RSP A77R6 DATED JANUARY 20, 2017 SUPERSEDES STANDARD PLAN A77R6
DATED OCTOBER 30, 2015 - PAGE 79 OF THE STANDARD PLANS BOOK DATED 2015.

REVISED STANDARD PLAN RSP A77R6

2015 REVISED STANDARD PLAN RSP A77R6

DIST	COUNTY	ROUTE	POST MILES TOTAL PROJECT	SHEET TOTAL SHEETS

Randell D. Hiatt
 REGISTERED CIVIL ENGINEER
 No. CS0200
 Exp. 6-30-17
 CIVIL
 STATE OF CALIFORNIA

January 20, 2017
 PLANS APPROVAL DATE
 THE STATE OF CALIFORNIA OR ITS OFFICERS OR AGENTS SHALL NOT BE RESPONSIBLE FOR THE ACCURACY OR COMPLETENESS OF SCANNED COPIES OF THIS PLAN SHEET.

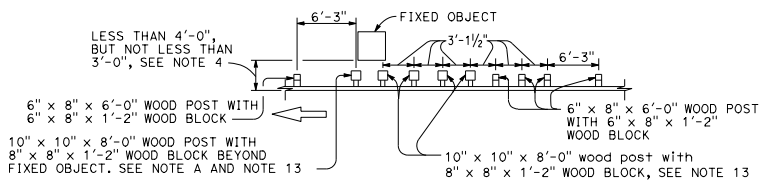

STRENGTHENED MIDWEST GUARDRAIL SYSTEM SECTIONS FOR FIXED OBJECT

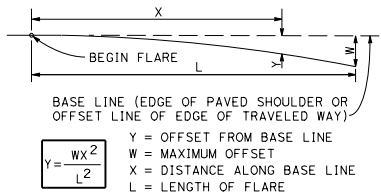

PARABOLIC FLARE OFFSETS

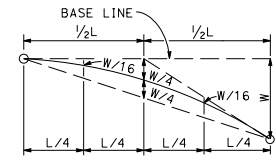

TYPICAL PARABOLIC LAYOUT

Use strengthened MGS sections with layout Types 16I or 16J Layouts where minimum clearance between the face of the MGS and fixed object(s) is less than 4'-0", but not less than 3'-0". See Note 4.

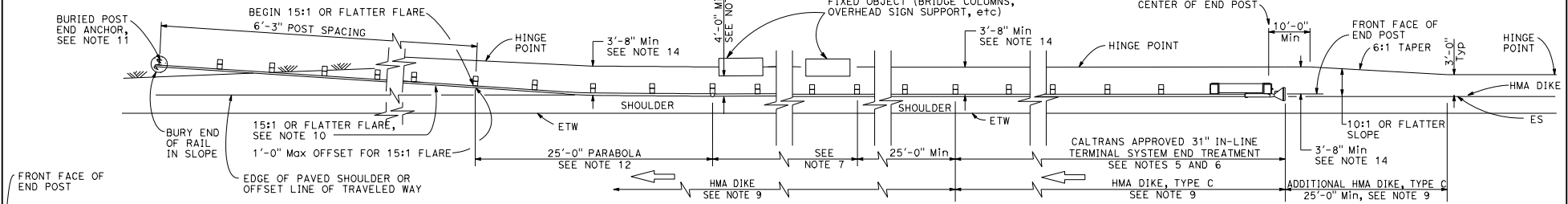

TYPE 16I LAYOUT

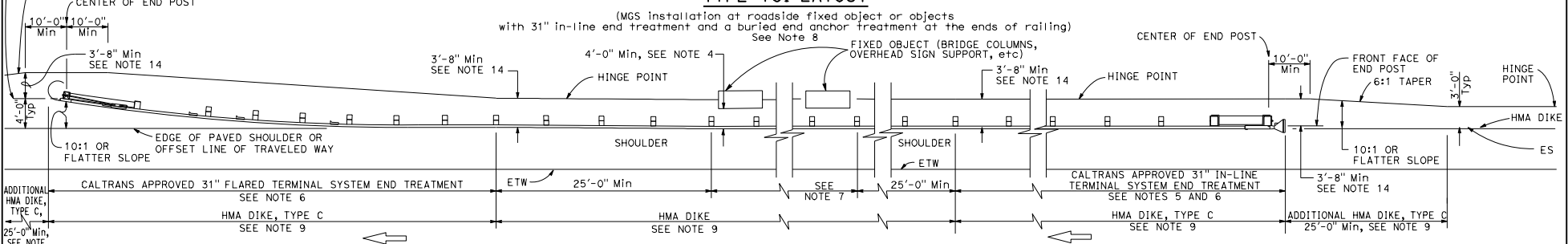

TYPE 16J LAYOUT

- NOTES:**
- Line post, blocks and hardware to be used are shown on Revised Standard Plans RSP A77L1, RSP A77L2, RSP A77M1, RSP A77N2 and Standard Plan A77M1.
 - MGS post spacing to be 6'-3" center to center, except as otherwise noted.
 - Except as noted, line posts are 6" x 8" x 6'-0" wood with 6" x 8" x 1'-2" wood blocks, W6 x 8.5 or W6 x 9 steel posts, 6'-0" in length, with 6" x 8" x 1'-2" notched wood blocks or notched recycled plastic blocks may be used for 6" x 8" x 6'-0" wood posts with 6" x 8" x 1'-2" wood blocks where applicable and when specified.
 - A 4'-0" minimum clearance is required between the face of the railing and the face of a fixed object located directly behind MGS sections with post spacing at 6'-3". Construct MGS as shown in the detail "Strengthened Midwest Guardrail System Sections for Fixed Objects" on this plan, where the clearance between the face of the railing and the face of a fixed object is less than 4'-0", but not less than 3'-0". Where the clearance is less than 3'-0", a concrete wall or barrier should be constructed to shield the fixed object(s).
 - 31" in-line terminal system end treatments are used where site conditions will not accommodate a 31" flared end treatment.
 - The type of 31" terminal system to be used will be shown on the Project Plans.
 - As site conditions dictate, construct additional MGS to shield fixed object(s). Additional MGS length equal to multiples of 12'-6". Post spacing at 6'-3", except as specified in Note 4.
 - Layout Types 16D through 16L, shown on the A77R Series of Standard Plans, are typically used where MGS is recommended to shield roadside fixed object(s) and a crashworthy 31" end treatment is required for both directions of traffic.
 - Where placement of dike is required with guard railing, see Standard Plan A77N4 for dike positioning details.
 - The 15:1 or flatter flare for the buried post end anchor is based on the edge of the paved shoulder or offset line of edge of the traveled way. The length of MGS within the 15:1 or flatter flare is based on site conditions and should be a length equal to multiples of 12'-6".
 - For details of Buried Post End Anchor, see Standard Plan A77T2.
 - For typical flare offsets for 25'-0" length parabola with maximum offset of 1'-0", see Revised Standard Plan RSP A77P1.
 - W6 x 15 steel post, 8'-0" in length, with 8" x 8" x 1'-2" notched wood block or notched recycled plastic blocks may be used in place of the 10" x 10" x 8'-0" wood post with 8" x 8" x 1'-2" wood block shown in the detail "Strengthened Midwest Guardrail System Sections for Fixed Object".
 - Use this offset for 8" block. For 12" block use minimum 4'-0" offset.

STATE OF CALIFORNIA
 DEPARTMENT OF TRANSPORTATION
MIDWEST GUARDRAIL SYSTEM
TYPICAL LAYOUTS FOR
ROADSIDE FIXED OBJECTS
 NO SCALE

RSP A77R7 DATED JANUARY 20, 2017 SUPERSEDES STANDARD PLAN A77R7
 DATED OCTOBER 30, 2015 - PAGE 80 OF THE STANDARD PLANS BOOK DATED 2015.
REVISED STANDARD PLAN RSP A77R7

2015 REVISED STANDARD PLAN RSP A77R7

DIST	COUNTY	ROUTE	POST MILES TOTAL PROJECT	SHEET TOTAL SHEETS

Randell D. Hiatt
REGISTERED CIVIL ENGINEER
No. CS0200
EXP. 6-30-17
CIVIL
STATE OF CALIFORNIA

January 20, 2017
PLANS APPROVAL DATE

THE STATE OF CALIFORNIA OR ITS OFFICERS OR AGENTS SHALL NOT BE RESPONSIBLE FOR THE ACCURACY OR COMPLETENESS OF SCANNED COPIES OF THIS PLAN SHEET.

TO ACCOMPANY PLANS DATED _____

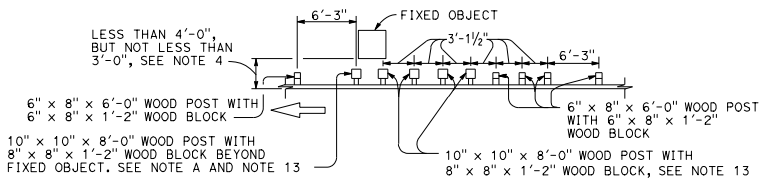

NOTE A: For a series of fixed objects (bridge columns, overhead sign supports, etc.) additional 10" x 10" x 8'-0" wood post with 8" x 8" x 1'-2" wood blocks at 3'-1/2" center to center spacing are to be used between fixed object(s).

STRENGTHENED MIDWEST GUARDRAIL SYSTEM SECTIONS FOR FIXED OBJECT

Use strengthened MGS sections with layout Types 16K or 16L layouts where minimum clearance between the face of the MGS and fixed object(s) is less than 4'-0", but not less than 3'-0". See Note 4.

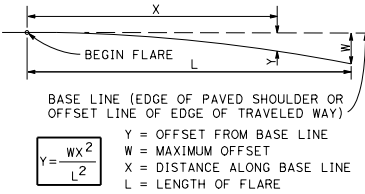

PARABOLIC FLARE OFFSETS

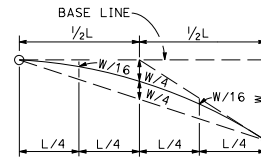

TYPICAL PARABOLIC LAYOUT

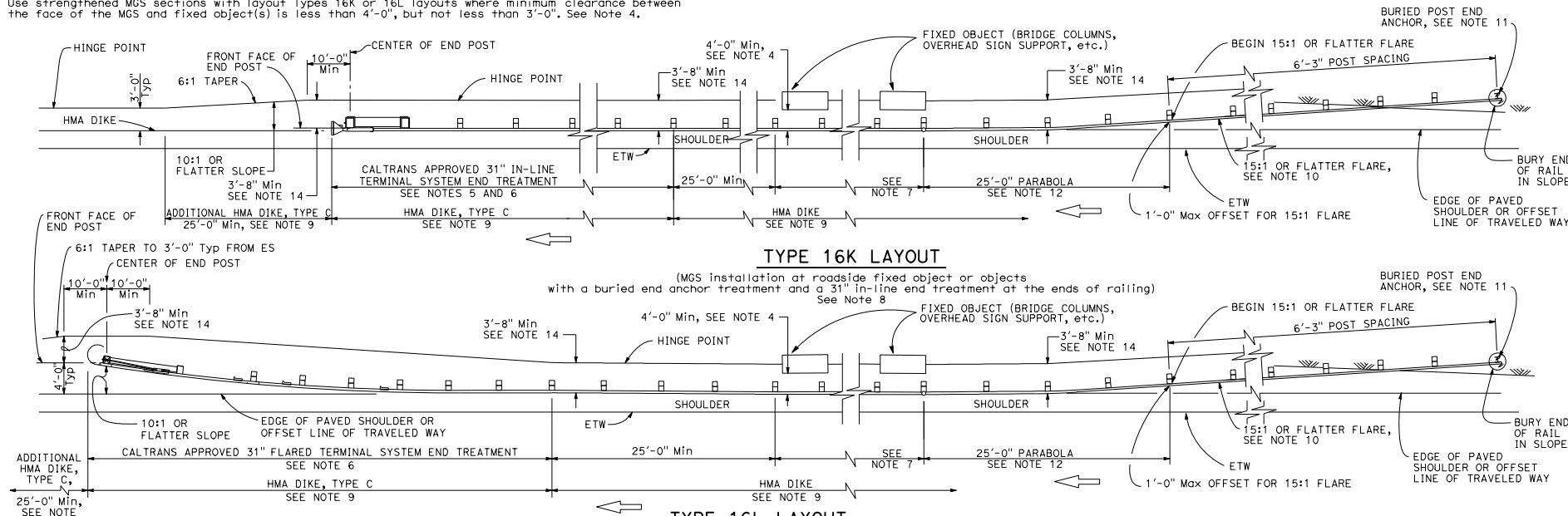

- NOTES:**
- Line post, blocks and hardware to be used are shown on Revised Standard Plans RSP A77L1, RSP A77L2, RSP A77N1, RSP A77N2 and Standard Plan A77M1.
 - MGS post spacing to be 6'-3" center to center, except as otherwise noted.
 - Except as noted, line posts are 6" x 8" x 6'-0" wood with 6" x 8" x 1'-2" wood blocks, W6 x 8.5 or W6 x 9 steel posts, 6'-0" in length, with 6" x 8" x 1'-2" notched wood blocks or notched recycled plastic blocks may be used for 6" x 8" x 6'-0" wood posts with 6" x 8" x 1'-2" wood blocks where applicable and when specified.
 - A 4'-0" minimum clearance is required between the face of the railing and the face of a fixed object located directly behind MGS sections with post spacing at 6'-3". Construct MGS as shown in the detail "Strengthened Midwest Guardrail System Sections for Fixed Objects" on this plan, where the clearance between the face of the railing and the face of a fixed object is less than 4'-0", but not less than 3'-0". Where the clearance is less than 3'-0", a concrete wall or barrier should be constructed to shield the fixed object(s).
 - 31" in-line terminal system end treatments are used where site conditions will not accommodate a 31" flared end treatment.
 - The type of 31" terminal system to be used will be shown on the Project Plans.
 - As site conditions dictate, construct additional MGS to shield fixed object(s). Additional MGS length equal to multiples of 12'-6". Post spacing at 6'-3", except as specified in Note 4.
 - Layout Types 16D through 16L, shown on the A77R Series of Standard Plans are typically used where MGS is recommended to shield roadside fixed object(s) and a crashworthy 31" end treatment is required for both directions of traffic.
 - Where placement of dike is required with MGS, see Standard Plan A77N4 for dike positioning details.
 - The 15:1 or flatter flare for the buried post anchor is based on the edge of the paved shoulder or offset line of edge of the traveled way. The length of MGS within the 15:1 or flatter flare is based on site conditions and should be a length equal to multiples of 12'-6".
 - For details of Buried Post End Anchor, see Standard Plan A77T2.
 - For typical flare offsets for 25'-0" length parabola with maximum offset of 1'-0", see Revised Standard Plan RSP A77P1.
 - W6 x 15 steel post, 8'-0" in length, with 8" x 8" x 1'-2" notched wood block or notched recycled plastic blocks may be used in place of the 10" x 10" x 8'-0" wood post with 8" x 8" x 1'-2" wood block shown in the detail "Strengthened Midwest Guardrail System Sections for Fixed Object".
 - Use this offset for 8" block. For 12" block use minimum 4'-0" offset.

STATE OF CALIFORNIA
DEPARTMENT OF TRANSPORTATION
**MIDWEST GUARDRAIL SYSTEM
TYPICAL LAYOUTS FOR
ROADSIDE FIXED OBJECTS**
NO SCALE
RSP A77R8 DATED JANUARY 20, 2017 SUPERSEDES STANDARD PLAN A77R8
DATED OCTOBER 30, 2015 - PAGE 81 OF THE STANDARD PLANS BOOK DATED 2015.
REVISED STANDARD PLAN RSP A77R8

2015 REVISED STANDARD PLAN RSP A77R8

Dist	COUNTY	ROUTE	POST MILES TOTAL PROJECT	SHEET NO.	TOTAL SHEETS
<i>Randell D. Hiatt</i> REGISTERED CIVIL ENGINEER					
April 20, 2018 PLANS APPROVAL DATE					
No. C50200 Exp. 6-30-19 CIVIL STATE OF CALIFORNIA					
<small>THE STATE OF CALIFORNIA OR ITS OFFICERS OR AGENTS SHALL NOT BE RESPONSIBLE FOR THE ACCURACY OR COMPLETENESS OF SCANNED COPIES OF THIS PLAN SHEET.</small>					

TO ACCOMPANY PLANS DATED _____

NOTES:

1. See Standard Plans A7703 and A77R1 for typical use of rail tensioning assembly.
2. For details of the anchor plate and 3/4" cable, see Standard Plan A77S5.

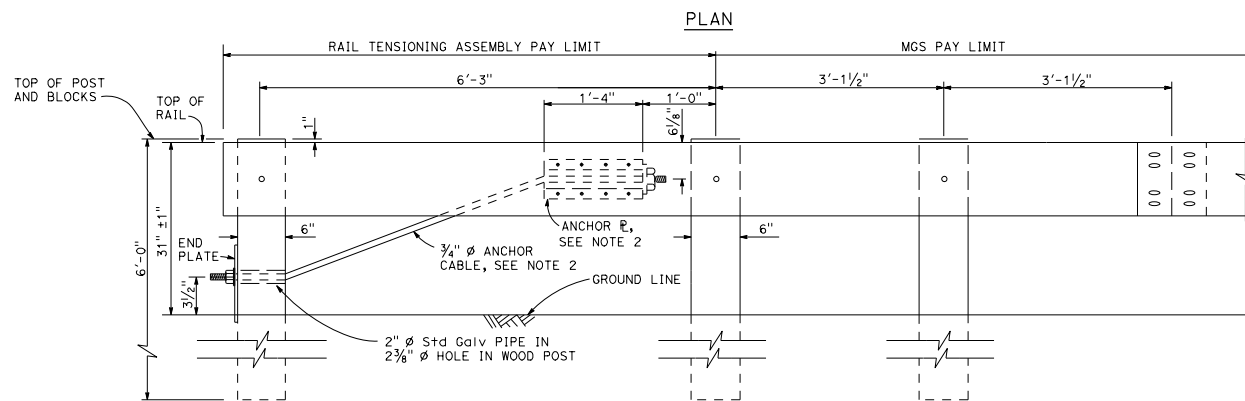
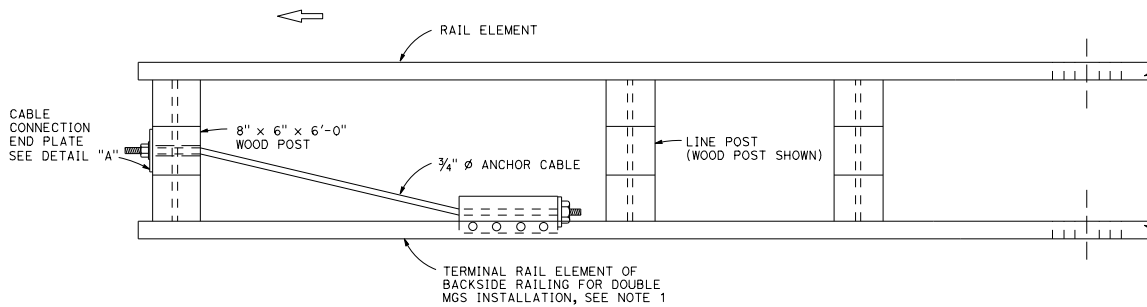

ELEVATION
RAIL TENSIONING
ASSEMBLY
See Note 1

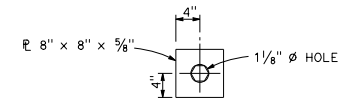

DETAIL "A"
CABLE CONNECTION
END PLATE

STATE OF CALIFORNIA
DEPARTMENT OF TRANSPORTATION

MIDWEST GUARDRAIL SYSTEM
RAIL TENSIONING ASSEMBLY

NO SCALE

RSP A77S2 DATED APRIL 20, 2018 SUPERSEDES STANDARD PLAN A77S2
DATED OCTOBER 30, 2015 - PAGE 83 OF THE STANDARD PLANS BOOK DATED 2015.

REVISED STANDARD PLAN RSP A77S2

2015 REVISED STANDARD PLAN RSP A77S2

DIST	COUNTY	ROUTE	POST MILES TOTAL PROJECT	SHEET TOTAL SHEETS

Randell D. Hiatt
REGISTERED CIVIL ENGINEER

January 20, 2017
PLANS APPROVAL DATE

No. C50200
Exp. 6-30-17
CIVIL
STATE OF CALIFORNIA

THE STATE OF CALIFORNIA OR ITS OFFICERS OR AGENTS SHALL NOT BE RESPONSIBLE FOR THE ACCURACY OR COMPLETENESS OF SCANNED COPIES OF THIS PLAN SHEET.

TO ACCOMPANY PLANS DATED _____

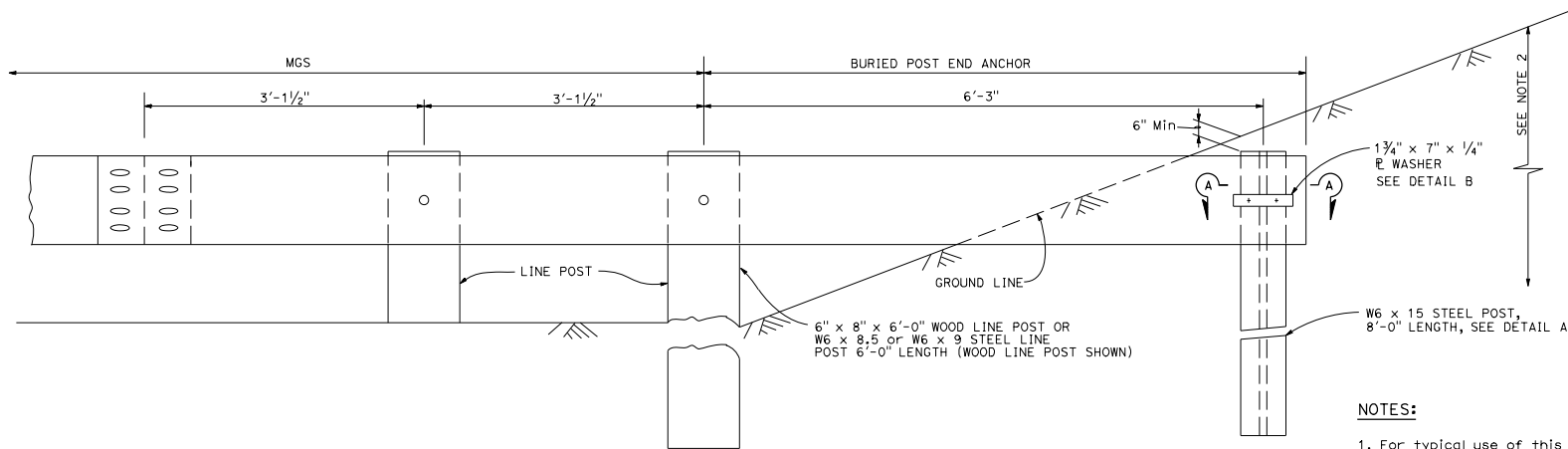

BURIED POST END ANCHOR

See Note 2

NOTES:

1. For typical use of this type of end anchor with MGS see the A77P, A77Q and A77R Series of the Standard Plans.
2. The buried post end anchor shall only be constructed at those locations where the slope perpendicular to the roadway is non-traversable.

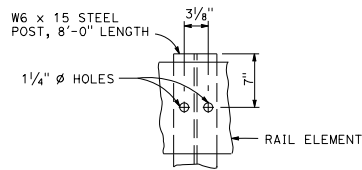

DETAIL A

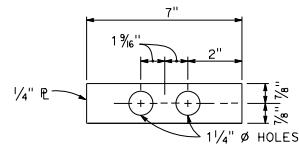

DETAIL B

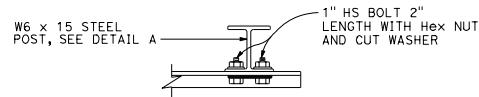

SECTION A-A

STATE OF CALIFORNIA
DEPARTMENT OF TRANSPORTATION

**MIDWEST GUARDRAIL SYSTEM
BURIED POST END ANCHOR**

NO SCALE

RSP A77T2 DATED JANUARY 20, 2017 SUPERSEDES STANDARD PLAN A77T2
DATED OCTOBER 30, 2015 - PAGE 86 OF THE STANDARD PLANS BOOK DATED 2015.

REVISED STANDARD PLAN RSP A77T2

2015 REVISED STANDARD PLAN RSP A77T2

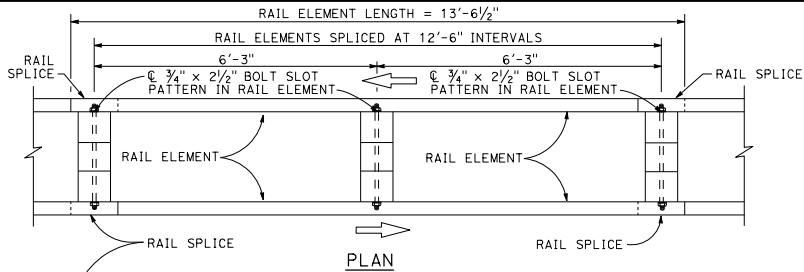

PLAN

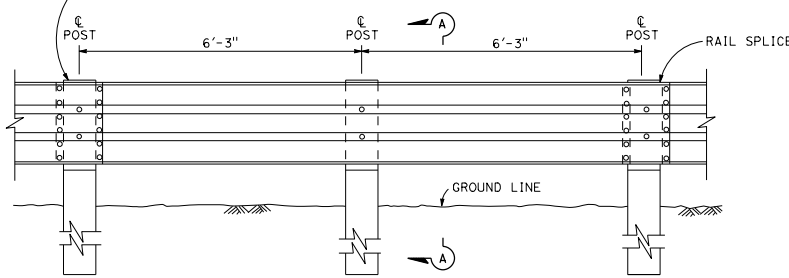

ELEVATION

DOUBLE THRIE BEAM BARRIER

(Wood post and blocks)
See Note 1

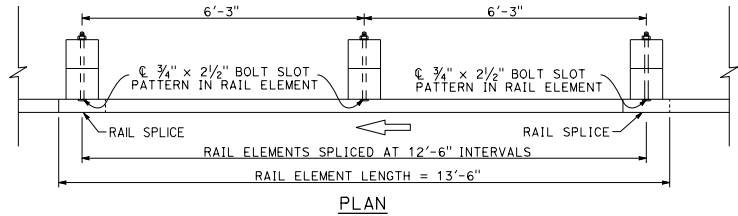

PLAN

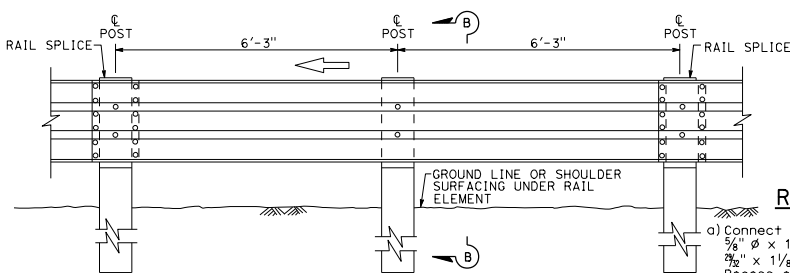

ELEVATION

SINGLE THRIE BEAM BARRIER

(Wood post and blocks)
See Note 1

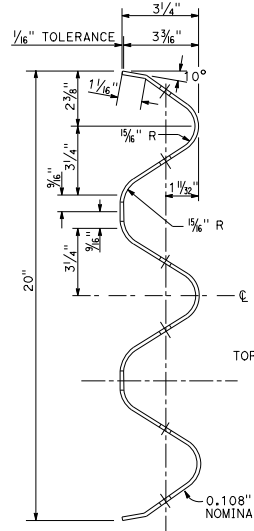

SECTION THRU
RAIL ELEMENT

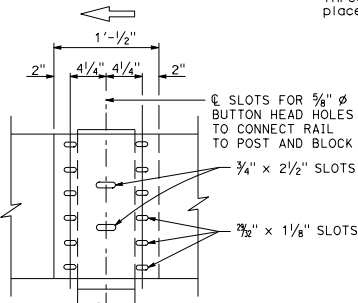

ELEVATION

RAIL ELEMENT SPLICE DETAIL

- Connect the overlapped ends of the thrie beam rail elements with $\frac{5}{8}$ " ϕ x $1\frac{1}{4}$ " button head oval shoulder bolts inserted into the $\frac{3}{4}$ " x $1\frac{1}{8}$ " slots and bolted together with $\frac{5}{8}$ " ϕ recessed hex nuts. Recess of hex nut points toward rail element. A total of 12 bolts and nuts are to be used at each rail splice connection.
- The ends of the rail elements are to be overlapped in the direction of traffic (see details).
- Where end cap is to be attached to the end of a rail element, a total of 4 of the above described splice bolts and nuts are to be used. Where a return cap is to be attached to the ends of rail elements, a total of 8 of the above described splice bolts and nuts are to be used.

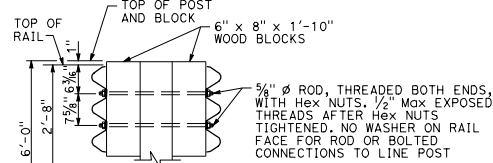

SECTION A-A
TYPICAL WOOD LINE
POST INSTALLATION

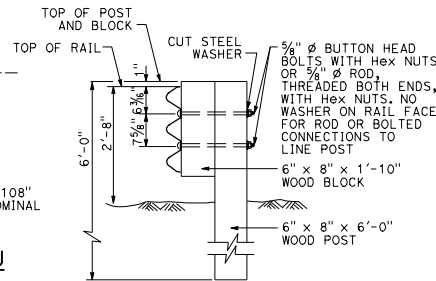

SECTION B-B
TYPICAL WOOD LINE
POST INSTALLATION

Where bolts are used, install so that the threaded end of the bolts and nuts are placed away from traffic side of rail.

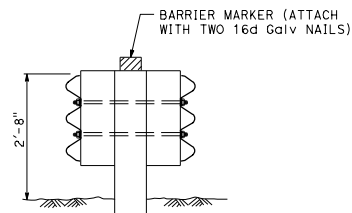

THRIE BEAM BARRIER
DELINEATION

See Note 8

DIST	COUNTY	ROUTE	POST MILES TOTAL PROJECT	SHEET TOTAL SHEETS

Randell D. Hiatt
 REGISTERED CIVIL ENGINEER
 No. C50200
 Exp. 6-30-19
 CIVIL
 STATE OF CALIFORNIA

April 20, 2018
 PLANS APPROVAL DATE
 THE STATE OF CALIFORNIA OR ITS OFFICERS OR AGENTS SHALL NOT BE RESPONSIBLE FOR THE ACCURACY OR COMPLETENESS OF SCANNED COPIES OF THIS PLAN SHEET.

TO ACCOMPANY PLANS DATED _____

NOTES:

- For details of steel post thrie beam barrier, see Standard Plan A78B.
- For details of standard hardware, posts and blocks used to construct thrie beam barrier, see Standard Plan A78C1 and A78C2.
- Thrie beam barrier post spacing to be 6'-3" center to center, except as otherwise noted.
- Top of barrier rail to be 2'-8" above ground line or shoulder surfacing under the rail element.
- For barrier end treatments and barrier connections, see Standard Plans A78E3 and A78G, and Standard Plans A78E1, A78E2, A77Q1, A77Q2 and A78H.
- For connection to Concrete Barrier (Type 60M), see Revised Standard Plans RSP A78I.
- For details of thrie beam barrier on bridge see Standard Plan A78D2. For details of thrie beam barrier at fixed object, see Standard Plan A78D1.
- See Project Plans for barrier delineation locations.

STATE OF CALIFORNIA
DEPARTMENT OF TRANSPORTATION

**THRIE BEAM BARRIER
STANDARD BARRIER RAILING
SECTION (WOOD POST
WITH WOOD BLOCK)**

NO SCALE

RSP A78A DATED APRIL 20, 2018 SUPERSEDES STANDARD PLAN A78A
DATED OCTOBER 30, 2015 - PAGE 94 OF THE STANDARD PLANS BOOK DATED 2015.

REVISED STANDARD PLAN RSP A78A

2015 REVISED STANDARD PLAN RSP A78A

Dist	COUNTY	ROUTE	POST MILES TOTAL PROJECT	SHEET TOTAL NO. SHEETS
<i>Chi H. Wong</i> REGISTERED CIVIL ENGINEER				
April 20, 2018 PLANS APPROVAL DATE				
THE STATE OF CALIFORNIA OR ITS OFFICERS OR AGENTS SHALL NOT BE RESPONSIBLE FOR THE ACCURACY OR COMPLETENESS OF SCANNED COPIES OF THIS PLAN SHEET.				

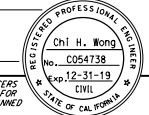

TO ACCOMPANY PLANS DATED _____

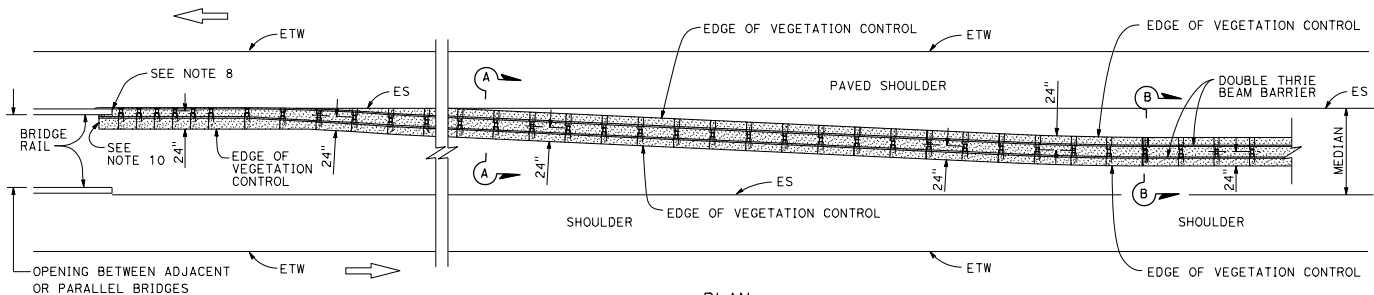

PLAN

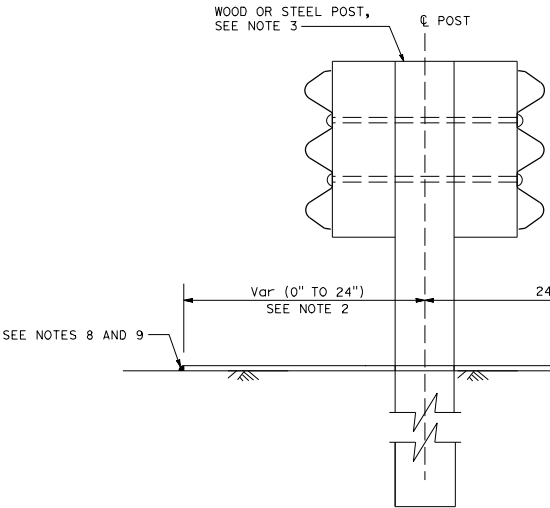

SECTION A-A

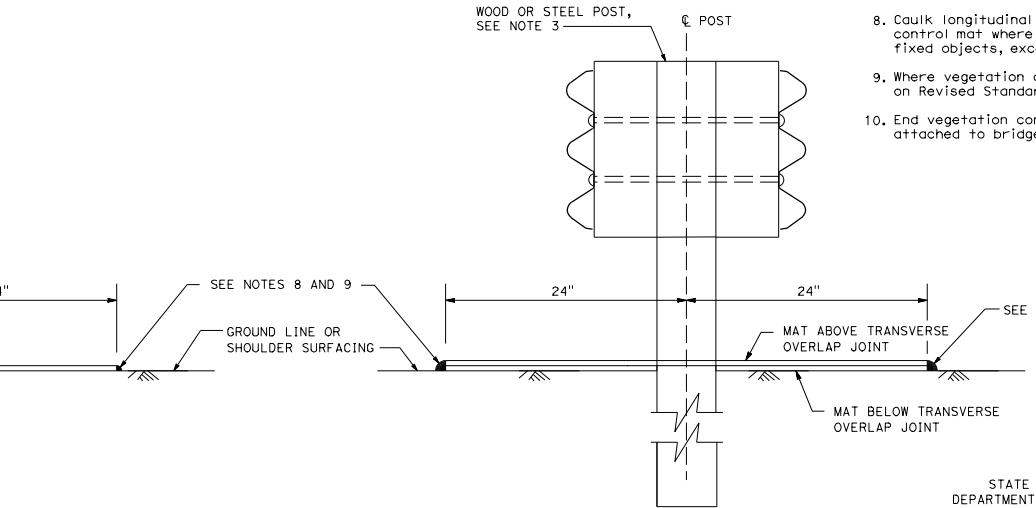

SECTION B-B

NOTES:

1. For additional vegetation control details, see Revised Standard Plan RSP A77N12.
2. Where dike is constructed under barrier, construct vegetation control to back edge of dike. Where paved shoulder is constructed within 24" of the post center, construct vegetation control to the edge of paved shoulder.
3. For wood and steel post sizes, see Standard Plan A78C2.
4. For details not shown, see Standard Plans A78A and A78B.
5. This plan for vegetation control installation only.
6. Vegetation control must slope in direction of water flow.
7. Place longitudinal and transverse overlap joint within the limits of vegetation control where applicable.
8. Caulk longitudinal and transverse edges of vegetation control mat where it abuts to paved surface or man-made fixed objects, except guardrail posts.
9. Where vegetation control is adjacent to a dike, see details on Revised Standard Plan RSP A77N12.
10. End vegetation control at end of backside rail element attached to bridge railing.

STATE OF CALIFORNIA
DEPARTMENT OF TRANSPORTATION
**FIBER OR RUBBER MAT
VEGETATION CONTROL
THRIE BEAM BARRIER
AT STRUCTURE APPROACH**
NO SCALE

RSP A78C10 DATED APRIL 20, 2018 SUPPLEMENTS THE STANDARD PLANS BOOK DATED 2015.

REVISED STANDARD PLAN RSP A78C10

2015 REVISED STANDARD PLAN RSP A78C10

DIST	COUNTY	ROUTE	POST MILES TOTAL PROJECT	SHEET NO.	TOTAL SHEETS

Chi H. Wong
 REGISTERED CIVIL ENGINEER
 No. C054738
 Exp. 12-31-19
 CIVIL
 STATE OF CALIFORNIA

April 20, 2018
 PLANS APPROVAL DATE
 THE STATE OF CALIFORNIA OR ITS OFFICERS OR AGENTS SHALL NOT BE RESPONSIBLE FOR THE ACCURACY OR COMPLETENESS OF SCANNED COPIES OF THIS PLAN SHEET.

TO ACCOMPANY PLANS DATED _____

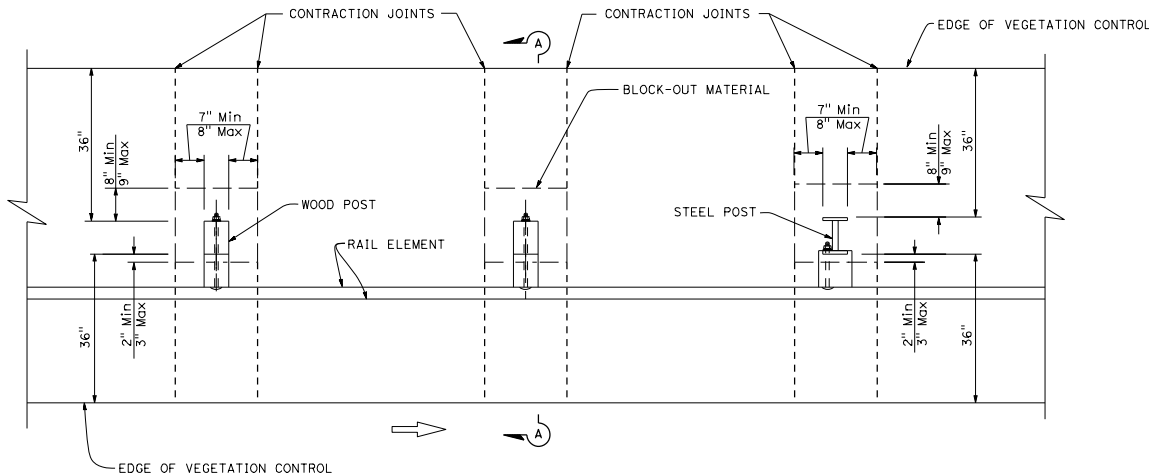

PLAN

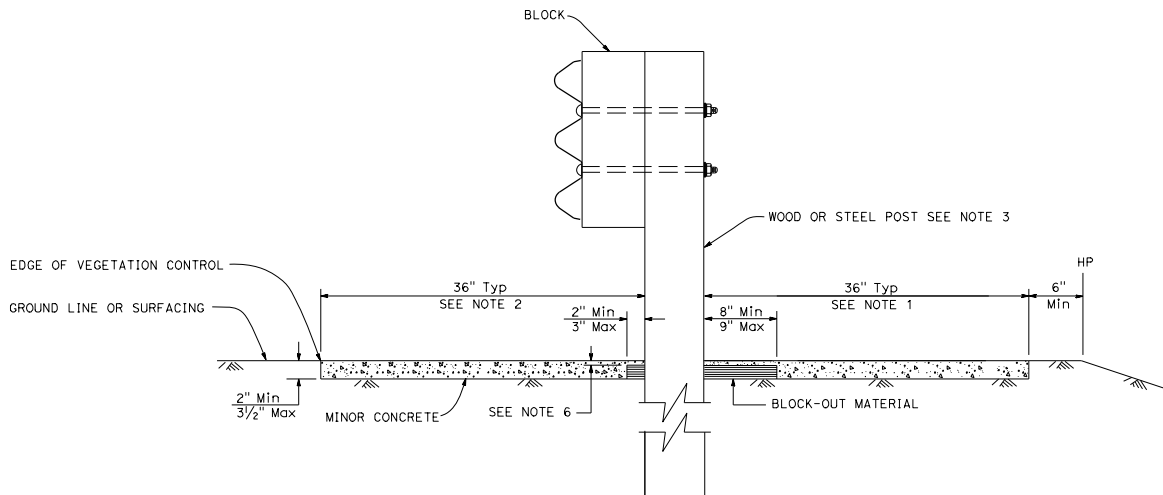

SECTION A-A

NOTES:

1. Where the distance between back of post and hinge point is less than 42", construct vegetation control to 6" from hinge point while maintaining the 8" block-out at back of post.
2. Where dike is constructed under barrier, construct vegetation control to back edge of dike. Where paved shoulder is constructed within 36" in front of the post, construct vegetation control to the edge of paved shoulder.
3. For wood and steel post sizes, see Standard Plan A78C2.
4. For details not shown, see Standard Plans A78A and A78B.
5. This plan for vegetation control installation only.
6. Concrete over block-out material depth, 3/8" Min to 5/8" Max.

STATE OF CALIFORNIA
DEPARTMENT OF TRANSPORTATION

**MINOR CONCRETE VEGETATION CONTROL
SINGLE THRIE BEAM BARRIER**

NO SCALE

RSP A78C3 DATED JULY 20, 2018 SUPERSEDES RSP A78C3 DATED JULY 21, 2017 AND STANDARD PLAN A78C3 DATED OCTOBER 30, 2015 - PAGE 98 OF THE STANDARD PLANS BOOK DATED 2015.

REVISED STANDARD PLAN RSP A78C3

2015 REVISED STANDARD PLAN RSP A78C3

DIST	COUNTY	ROUTE	POST MILES TOTAL PROJECT	SHEET NO.	TOTAL SHEETS
<p><i>Chi H. Wong</i> REGISTERED CIVIL ENGINEER</p> <p>April 20, 2018 PLANS APPROVAL DATE</p> <p>Chi H. Wong No. C054738 Exp. 12-31-19 CIVIL STATE OF CALIFORNIA</p> <p>THE STATE OF CALIFORNIA OR ITS OFFICERS OR AGENTS SHALL NOT BE RESPONSIBLE FOR THE ACCURACY OR COMPLETENESS OF SCANNED COPIES OF THIS PLAN SHEET.</p>					

TO ACCOMPANY PLANS DATED _____

2015 REVISED STANDARD PLAN RSP A78C4

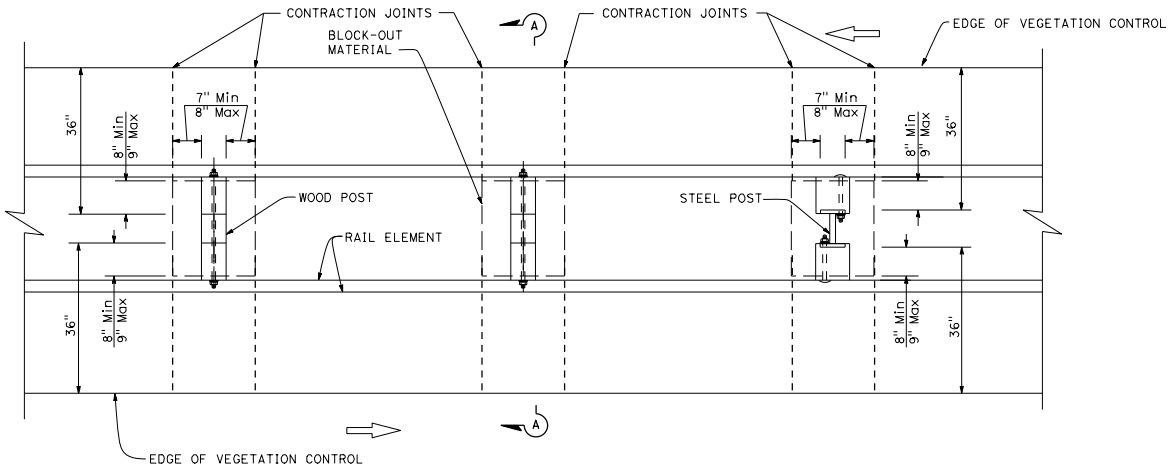

PLAN

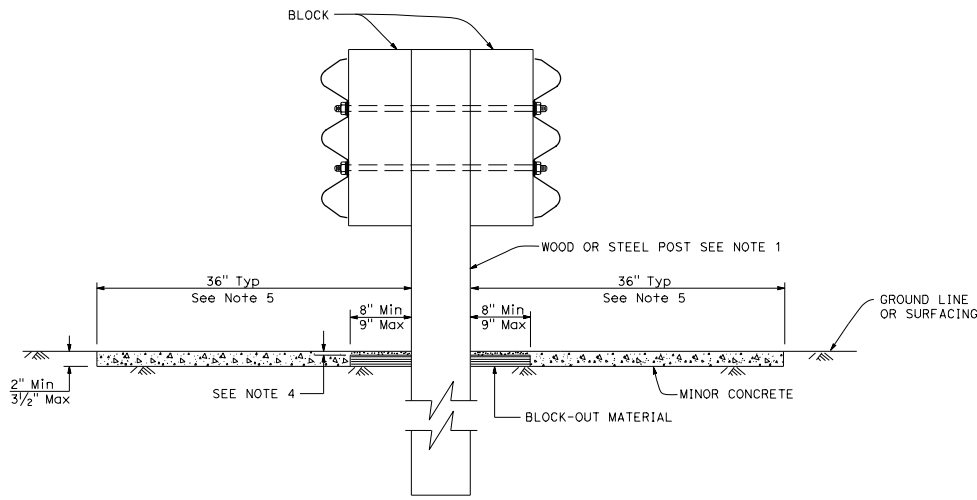

SECTION A-A

NOTES:

1. For wood and steel post sizes, see Standard Plan A78C2.
2. For details not shown, see Standard Plans A78A and A78B.
3. This plan for vegetation control installation only.
4. Concrete over block-out material depth, $\frac{3}{8}$ " Min to $\frac{5}{8}$ " Max.
5. Vegetation control must not conflict with drainage facilities.

STATE OF CALIFORNIA
DEPARTMENT OF TRANSPORTATION

**MINOR CONCRETE VEGETATION CONTROL
DOUBLE THRIE BEAM BARRIER**

NO SCALE

RSP A78C4 DATED APRIL 20, 2018 SUPERSEDES RSP A78C4 DATED JULY 21, 2017 AND STANDARD PLAN A78C4 DATED OCTOBER 30, 2015 - PAGE 99 OF THE STANDARD PLANS BOOK DATED 2015.

REVISED STANDARD PLAN RSP A78C4

DIST	COUNTY	ROUTE	POST MILES TOTAL PROJECT	SHEET TOTAL SHEETS
<i>Chi H. Wong</i> REGISTERED CIVIL ENGINEER				
April 20, 2018 PLANS APPROVAL DATE				
No. C054738 Exp. 12-31-19 CIVIL				
THE STATE OF CALIFORNIA OR ITS OFFICERS OR AGENTS SHALL NOT BE RESPONSIBLE FOR THE ACCURACY OR COMPLETENESS OF SCANNED COPIES OF THIS PLAN SHEET.				

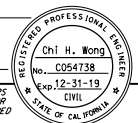

TO ACCOMPANY PLANS DATED _____

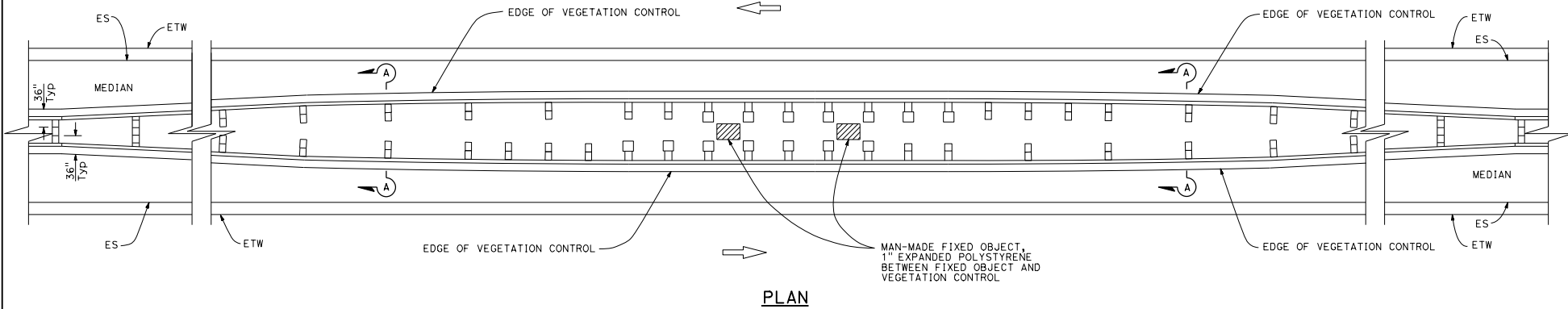

PLAN

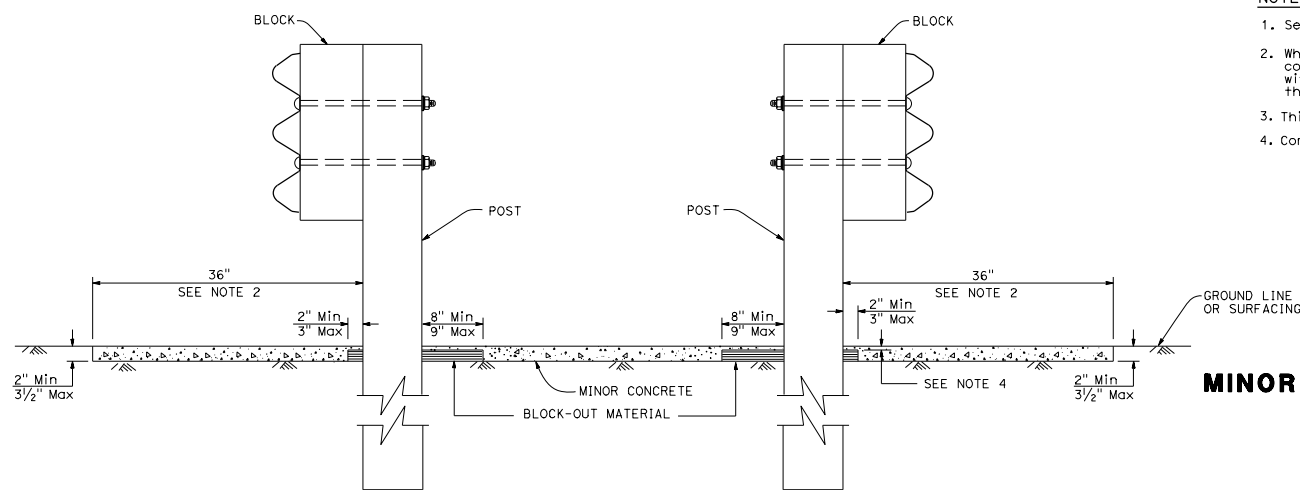

SECTION A-A

NOTES:

1. See Revised Standard Plan RSP A78C3 for additional vegetation control.
2. Where dike is constructed under barrier, construct vegetation control to back edge of dike. Where paved shoulder is constructed within 36" in front of the post, construct vegetation control to the edge of paved shoulder.
3. This plan for vegetation control installation only.
4. Concrete over block-out material depth, 3/8" Min to 5/8" Max.

STATE OF CALIFORNIA
DEPARTMENT OF TRANSPORTATION
**MINOR CONCRETE VEGETATION CONTROL
THRIE BEAM BARRIER
AT FIXED OBJECTS
IN MEDIAN**
NO SCALE

RSP A78C5 DATED APRIL 20, 2018 SUPERSEDES RSP A78C5 DATED JULY 21, 2017 AND STANDARD PLAN A78C5 DATED OCTOBER 30, 2015 - PAGE 100 OF THE STANDARD PLANS BOOK DATED 2015.

REVISED STANDARD PLAN RSP A78C5

2015 REVISED STANDARD PLAN RSP A78C5

DIST	COUNTY	ROUTE	POST MILES TOTAL PROJECT	SHEET NO.	TOTAL SHEETS
<i>Chi H. Wong</i> REGISTERED CIVIL ENGINEER No. C054738 Exp. 12-31-19 CIVIL STATE OF CALIFORNIA					
APRIL 20, 2018 PLANS APPROVAL DATE THE STATE OF CALIFORNIA OR ITS OFFICERS OR AGENTS SHALL NOT BE RESPONSIBLE FOR THE ACCURACY OR COMPLETENESS OF SCANNED COPIES OF THIS PLAN SHEET.					

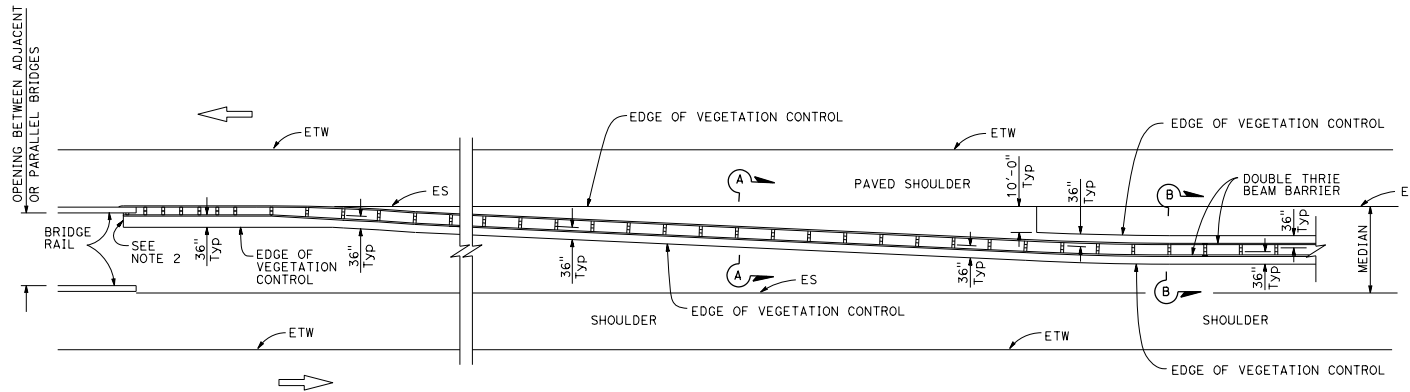

- NOTES:**
1. See Revised Standard Plan RSP A78C4 for additional vegetation control details.
 2. End vegetation control at end of backside rail element attached to bridge railing.
 3. This plan for vegetation control installation only.
 4. Concrete over block-out material depth, 3/8" Min to 5/8" Max.

PLAN

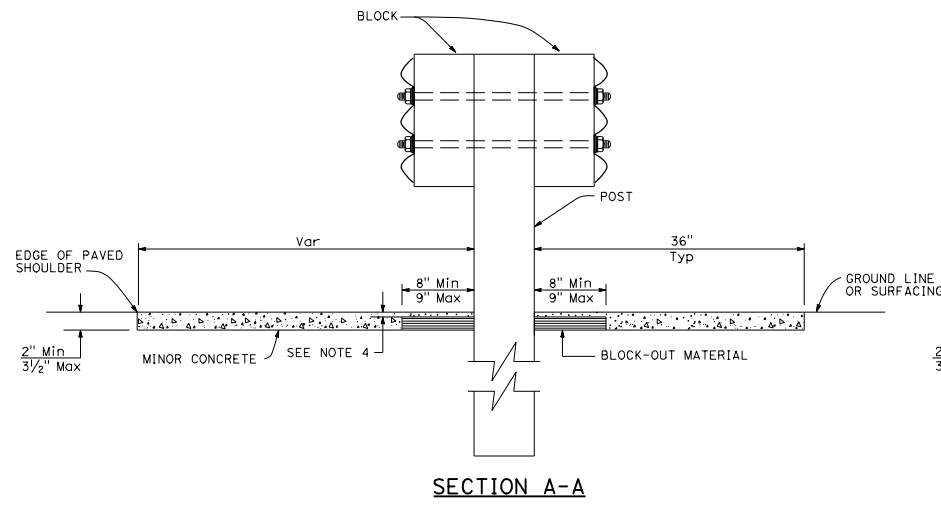

SECTION A-A

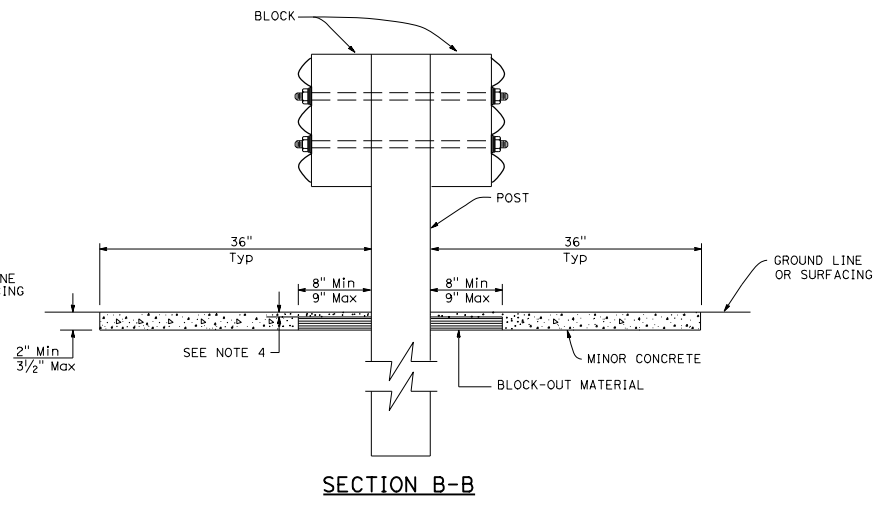

SECTION B-B

STATE OF CALIFORNIA
DEPARTMENT OF TRANSPORTATION

**MINOR CONCRETE VEGETATION CONTROL
THREE BEAM BARRIER
AT STRUCTURE APPROACH**

NO SCALE

RSP A78C6 DATED APRIL 20, 2018 SUPERSEDES RSP A78C6 DATED JULY 21, 2017 AND STANDARD PLAN A78C6 DATED OCTOBER 30, 2015 - PAGE 101 OF THE STANDARD PLANS BOOK DATED 2015.

REVISED STANDARD PLAN RSP A78C6

2015 REVISED STANDARD PLAN RSP A78C6

DIST	COUNTY	ROUTE	POST MILES TOTAL PROJECT	SHEET TOTAL SHEETS
<i>Chi H. Wong</i> REGISTERED CIVIL ENGINEER				
April 20, 2018 PLANS APPROVAL DATE				
No. C054738 Exp. 12-31-19 CIVIL				
THE STATE OF CALIFORNIA OR ITS OFFICERS OR AGENTS SHALL NOT BE RESPONSIBLE FOR THE ACCURACY OR COMPLETENESS OF SCANNED COPIES OF THIS PLAN SHEET.				

TO ACCOMPANY PLANS DATED _____

NOTES:

- For additional vegetation control details, see Revised Standard Plan RSP A77N12.
- Where dike is constructed under barrier, construct vegetation control to back edge of dike. Where paved shoulder is constructed within 24" of the post center, construct vegetation control to the edge of paved shoulder.
- For wood and steel post sizes, see Standard Plan A78C2.
- For details not shown, see Revised Standard Plan RSP A78A and Standard Plan A78B.
- This plan for vegetation control installation only.
- Vegetation control must slope in direction of water flow.
- Place transverse and longitudinal overlap joint within the limits of vegetation control where applicable.
- Caulk longitudinal and transverse edges of vegetation control mat where it abuts to paved surface or man-made fixed objects, except guardrail posts.
- Where vegetation control is adjacent to a dike, see details on Revised Standard Plan RSP A77N12.
- Where the distance between center of post and hinge point is less than 30", construct vegetation control to 6" from the hinge point. For narrow installation, see Revised Standard Plan RSP A77N13.

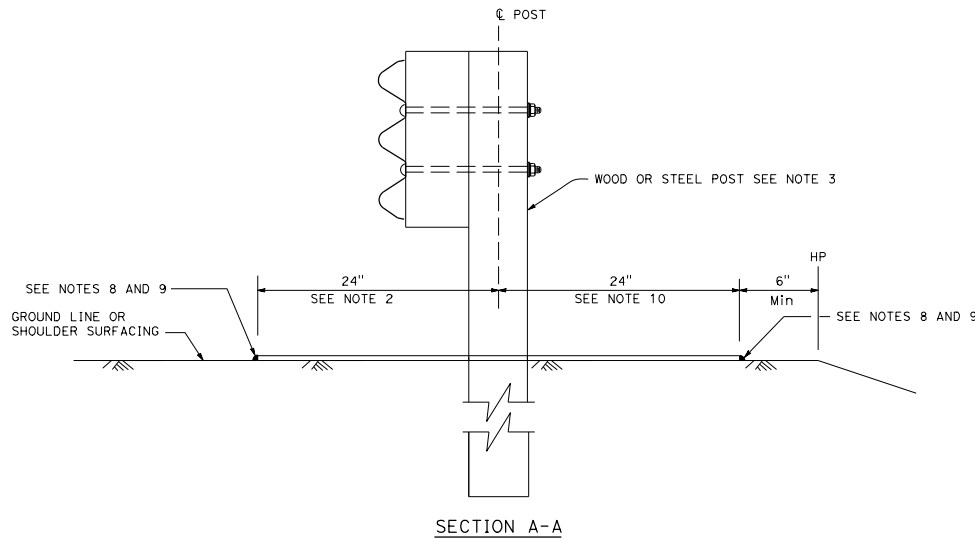
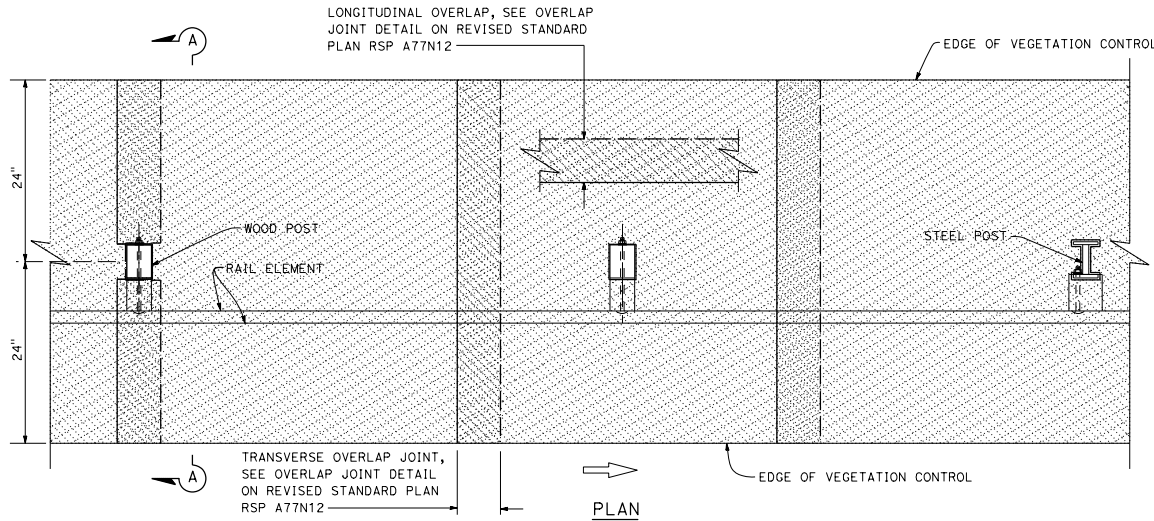

STATE OF CALIFORNIA
DEPARTMENT OF TRANSPORTATION
**FIBER OR RUBBER MAT
VEGETATION CONTROL
SINGLE THRIE BEAM BARRIER**
NO SCALE

RSP A78C7 DATED APRIL 20, 2018 SUPPLEMENTS THE STANDARD PLANS BOOK DATED 2015.

REVISED STANDARD PLAN RSP A78C7

2015 REVISED STANDARD PLAN RSP A78C7

DIST	COUNTY	ROUTE	POST MILES TOTAL PROJECT	SHEET TOTAL SHEETS

Chi H. Wong
 REGISTERED CIVIL ENGINEER

April 20, 2018
 PLANS APPROVAL DATE

No. C054738
 Exp. 12-31-19
 CIVIL

THE STATE OF CALIFORNIA OR ITS OFFICERS OR AGENTS SHALL NOT BE RESPONSIBLE FOR THE ACCURACY OR COMPLETENESS OF SCANNED COPIES OF THIS PLAN SHEET.

TO ACCOMPANY PLANS DATED _____

NOTES:

- For additional vegetation control details, see Revised Standard Plan RSP A77N12.
- Where dike is constructed under barrier, construct vegetation control to back edge of dike. Where paved shoulder is constructed within 24" of the post center, construct vegetation control to the edge of paved shoulder.
- For wood and steel post sizes, see Standard Plan A78C2.
- For details not shown, see Revised Standard Plan RSP A78A and Standard Plan A78B.
- This plan for vegetation control installation only.
- Vegetation control must slope in direction of water flow.
- Place transverse and longitudinal overlap joint within the limits of vegetation control where applicable.
- Caulk longitudinal and transverse edges of vegetation control mat where it abuts to paved surface or man-made fixed objects, except guardrail posts.
- Where vegetation control is adjacent to a dike, see details on Revised Standard Plan RSP A77N12.

2015 REVISED STANDARD PLAN RSP A78C8

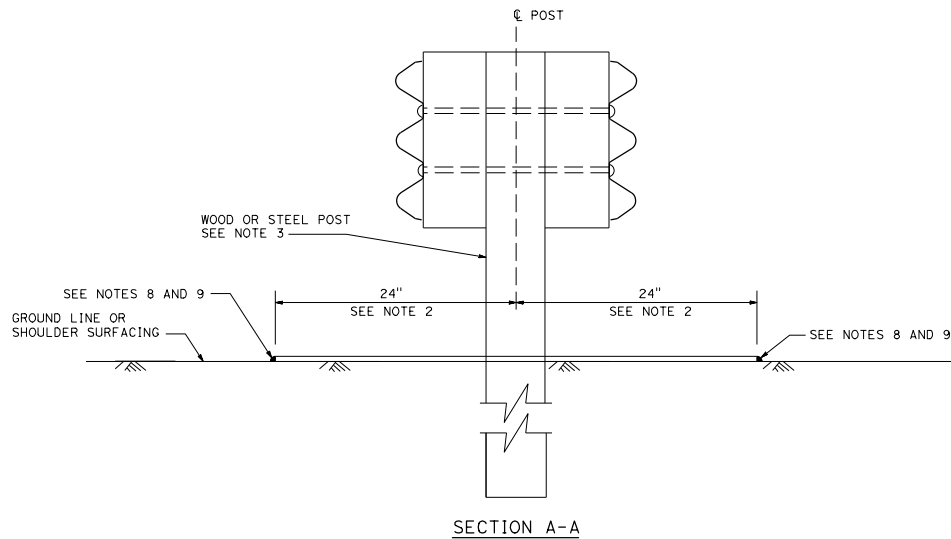
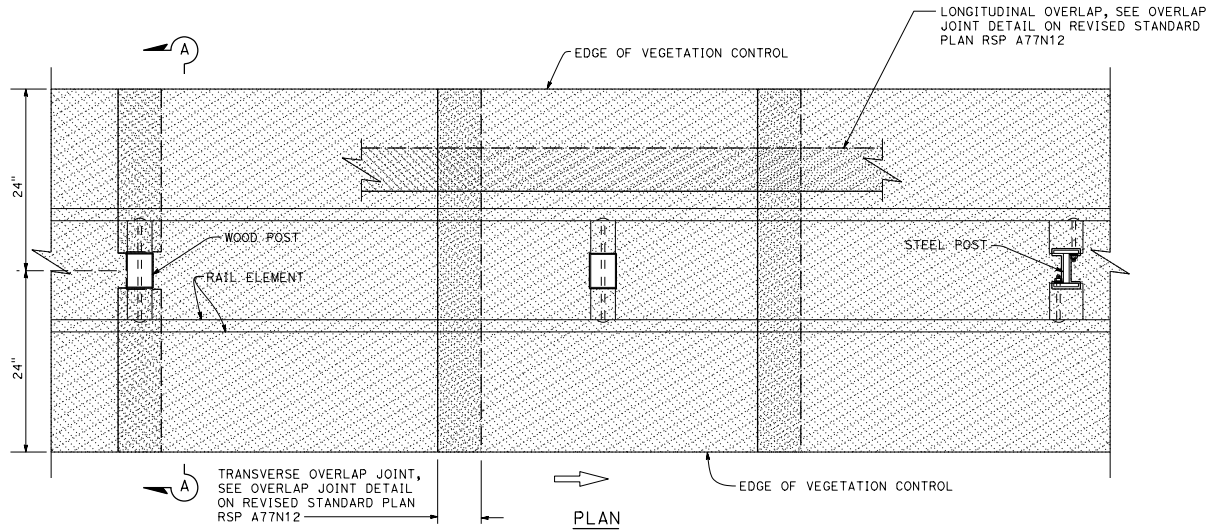

STATE OF CALIFORNIA
 DEPARTMENT OF TRANSPORTATION
**FIBER OR RUBBER MAT
 VEGETATION CONTROL
 DOUBLE THRIE BEAM BARRIER**
 NO SCALE

RSP A78C8 DATED APRIL 20, 2018 SUPPLEMENTS THE STANDARD PLANS BOOK DATED 2015.

REVISED STANDARD PLAN RSP A78C8

DIST	COUNTY	ROUTE	POST MILES TOTAL PROJECT	SHEET TOTAL SHEETS

Chi H. Wong
 REGISTERED CIVIL ENGINEER

April 20, 2018
 PLANS APPROVAL DATE

REGISTERED PROFESSIONAL ENGINEER
 Chi H. Wong
 No. C054738
 Exp. 12-31-19
 CIVIL
 STATE OF CALIFORNIA

THE STATE OF CALIFORNIA OR ITS OFFICERS OR AGENTS SHALL NOT BE RESPONSIBLE FOR THE ACCURACY OR COMPLETENESS OF SCANNED COPIES OF THIS PLAN SHEET.

TO ACCOMPANY PLANS DATED _____

NOTES:

- For additional vegetation control details, see Revised Standard Plan RSP A77N12.
- Where dike is constructed under barrier, construct vegetation control to back edge of dike. Where paved shoulder is constructed within 24" of the post center, construct vegetation control to the edge of paved shoulder.
- For wood and steel post sizes, see Standard Plan A78C2.
- For details not shown, see Revised Standard Plan RSP A78A and Standard Plan A78B.
- This plan for vegetation control installation only.
- Vegetation control must slope in direction of water flow.
- Place transverse and longitudinal overlap joint within the limits of vegetation control where applicable.
- Cauk longitudinal and transverse edges of vegetation control mat where it abuts to paved surface or man-made fixed objects, except guardrail posts.
- Where vegetation control is adjacent to a dike, see details on Revised Standard Plan RSP A77N12.

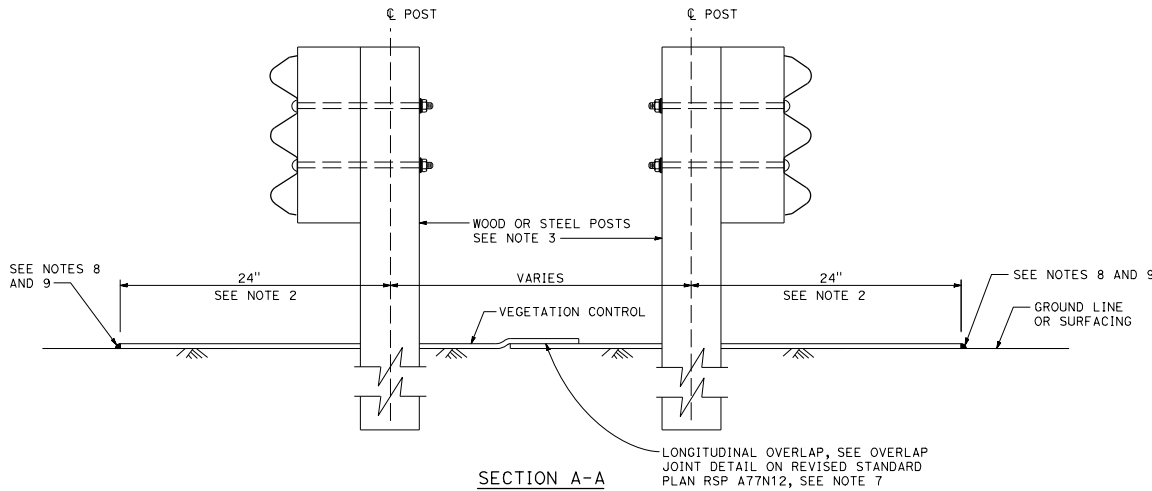

SECTION A-A
LONGITUDINAL OVERLAP, SEE OVERLAP JOINT DETAIL ON REVISED STANDARD PLAN RSP A77N12, SEE NOTE 7

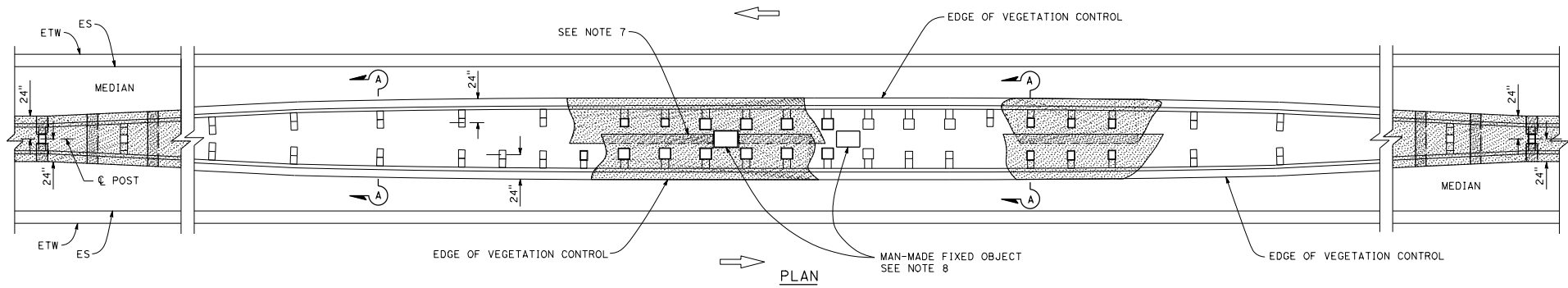

STATE OF CALIFORNIA
DEPARTMENT OF TRANSPORTATION

**FIBER OR RUBBER MAT
VEGETATION CONTROL
THREE BEAM BARRIER AT
FIXED OBJECTS IN MEDIAN**

NO SCALE

RSP A78C9 DATED APRIL 20, 2018 SUPPLEMENTS THE STANDARD PLANS BOOK DATED 2015.

REVISED STANDARD PLAN RSP A78C9

2015 REVISED STANDARD PLAN RSP A78C9

DIST	COUNTY	ROUTE	POST MILES TOTAL PROJECT	SHEET NO.	TOTAL SHEETS

Randell D. Hiatt
REGISTERED CIVIL ENGINEER

April 20, 2018
PLANS APPROVAL DATE

No. C50200
Exp. 6-30-19
CIVIL
STATE OF CALIFORNIA

REGISTERED PROFESSIONAL ENGINEER

THE STATE OF CALIFORNIA OR ITS OFFICERS OR AGENTS SHALL NOT BE RESPONSIBLE FOR THE ACCURACY OR COMPLETENESS OF SCANNED COPIES OF THIS PLAN SHEET.

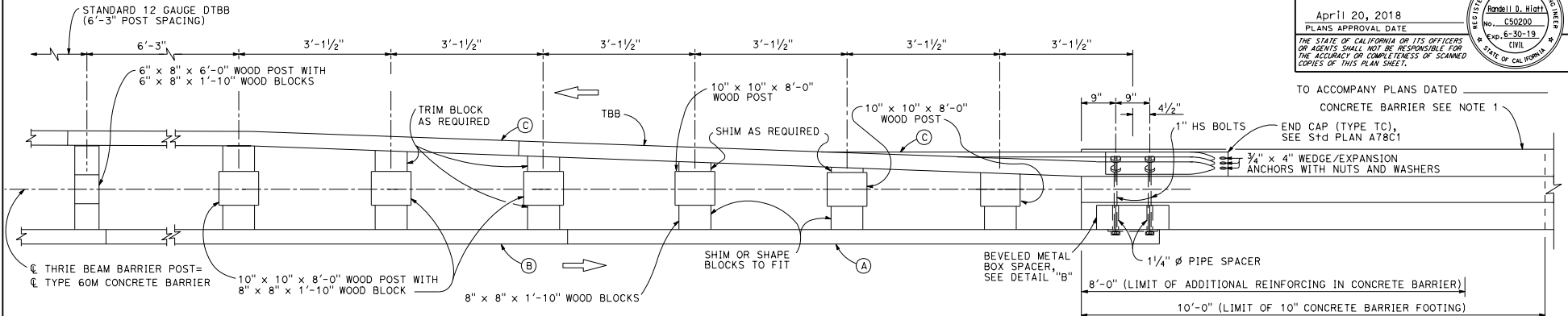

PLAN

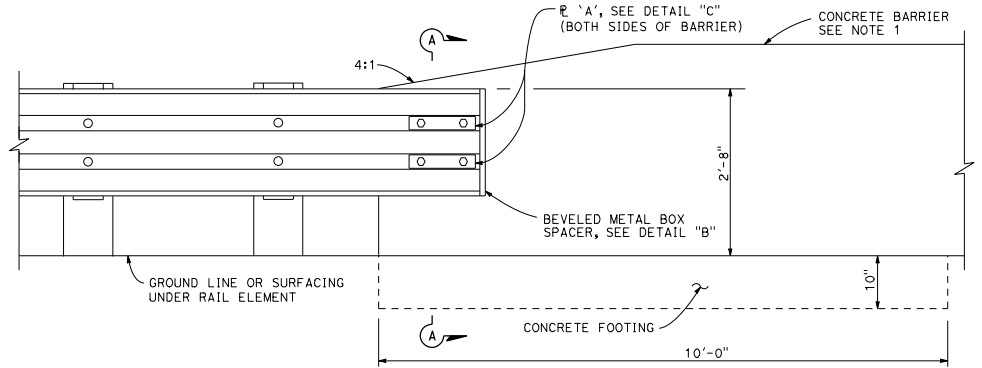
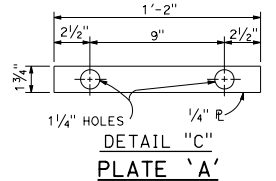
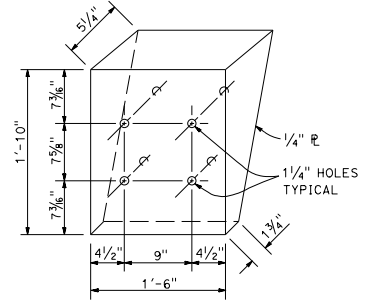

NOTES:

- For details of Concrete Barrier Type 60M, see Revised Standard Plan RSP A76A. Thrie beam barrier connections to Concrete Barrier Type 60MS and Type 60MG are similar to details shown on this plan.
- For additional thrie beam barrier details, see Revised Standard Plan RSP A78A, Standard Plans A78B, A78C1, and A78C2.
- Where beveled metal box spacer is installed, place 1/4" ϕ x 3/4" and 1/4" ϕ x 2" pipe spacers on 1" HS bolts passing through interior of box.

LEGEND

- (A) NESTED THRIE BEAM ELEMENTS (ONE 12 GAUGE ELEMENT NESTED OVER ONE 10 GAUGE ELEMENT).
 - (B) ONE 10 GAUGE THRIE BEAM ELEMENT.
 - (C) ONE 12 GAUGE THRIE BEAM ELEMENT.
- 10 GAUGE = 0.135" THICK
12 GAUGE = 0.108" THICK

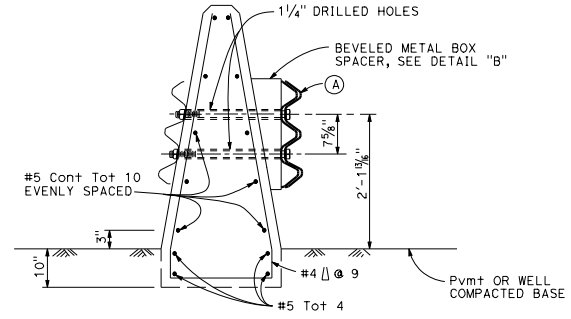

STATE OF CALIFORNIA
DEPARTMENT OF TRANSPORTATION

**DOUBLE THRIE BEAM BARRIER
CONNECTION TO CONCRETE
BARRIER**

NO SCALE

RSP A781 DATED APRIL 20, 2018 SUPERSEDES STANDARD PLAN A781
DATED OCTOBER 30, 2015 - PAGE 111 OF THE STANDARD PLANS BOOK DATED 2015.

REVISED STANDARD PLAN RSP A781

2015 REVISED STANDARD PLAN RSP A781

DIST	COUNTY	ROUTE	POST MILES TOTAL PROJECT	SHEET TOTAL SHEETS

Raymond Don Tezton
 REGISTERED CIVIL ENGINEER
 No. C37332
 PLAN'S APPROVAL DATE July 15, 2016
THE STATE OF CALIFORNIA OR ITS OFFICERS OR AGENTS SHALL NOT BE RESPONSIBLE FOR THE ACCURACY OR COMPLETENESS OF SCANNED COPIES OF THIS PLAN SHEET.

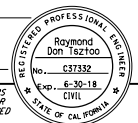

TO ACCOMPANY PLANS DATED _____

LEGEND:

Desert Tortoise Habitat

NOTES:

- Exact locations for temporary desert tortoise fence are shown on the plans.
- Horizontal portion of hardware cloth must be on habitat side of posts.

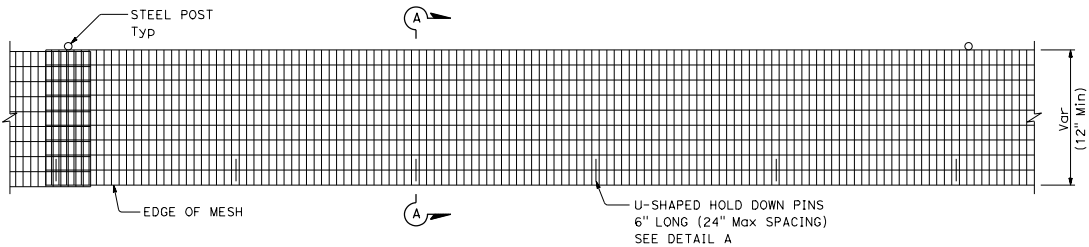

PLAN VIEW

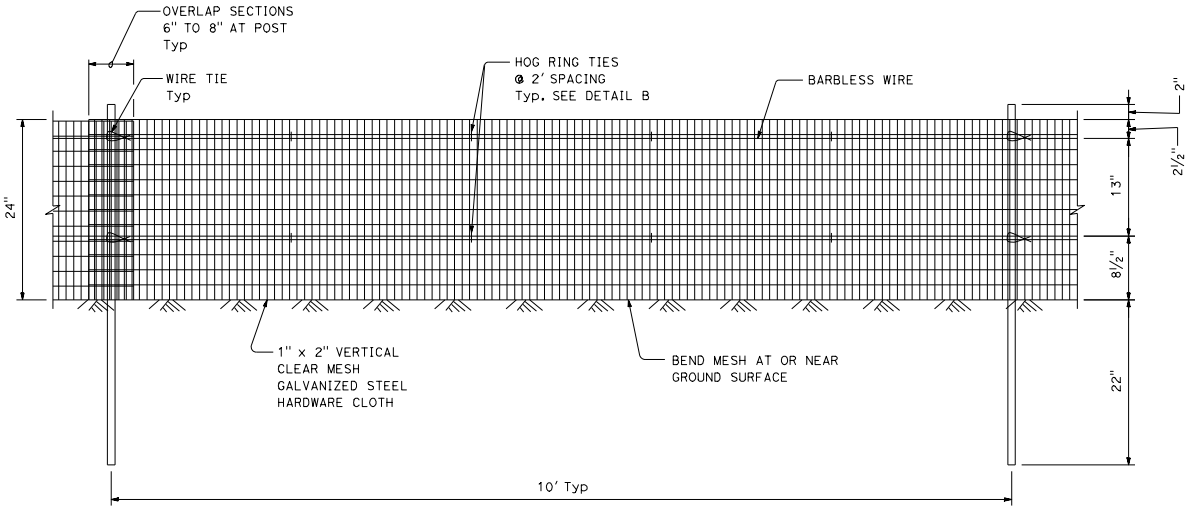

FRONT VIEW

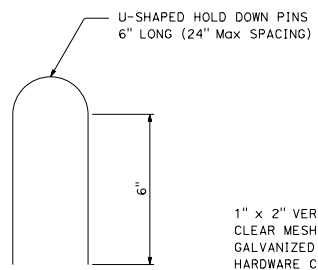

DETAIL A

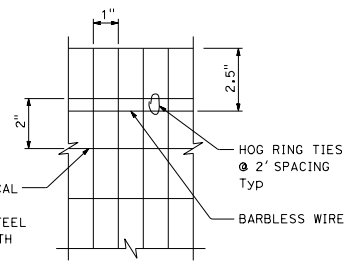

DETAIL B

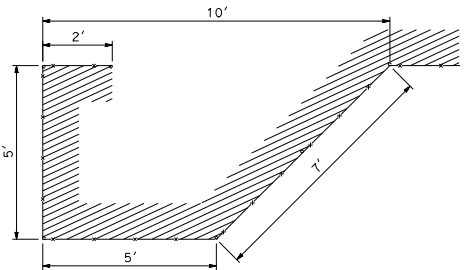

REDIRECTIONAL CONFIGURATION PLAN VIEW

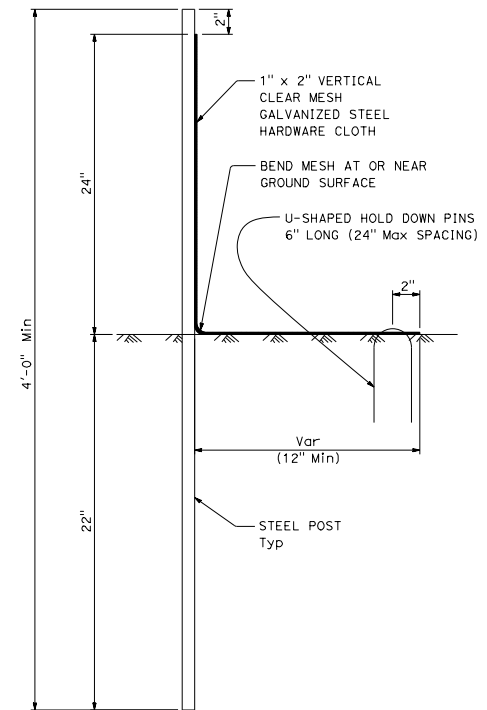

SECTION A-A

STATE OF CALIFORNIA
DEPARTMENT OF TRANSPORTATION
TEMPORARY DESERT TORTOISE FENCE
NO SCALE

RSP A84A DATED JULY 15, 2016 SUPPLEMENTS THE STANDARD PLANS BOOK DATED 2015.

REVISED STANDARD PLAN RSP A84A

2015 REVISED STANDARD PLAN RSP A84A

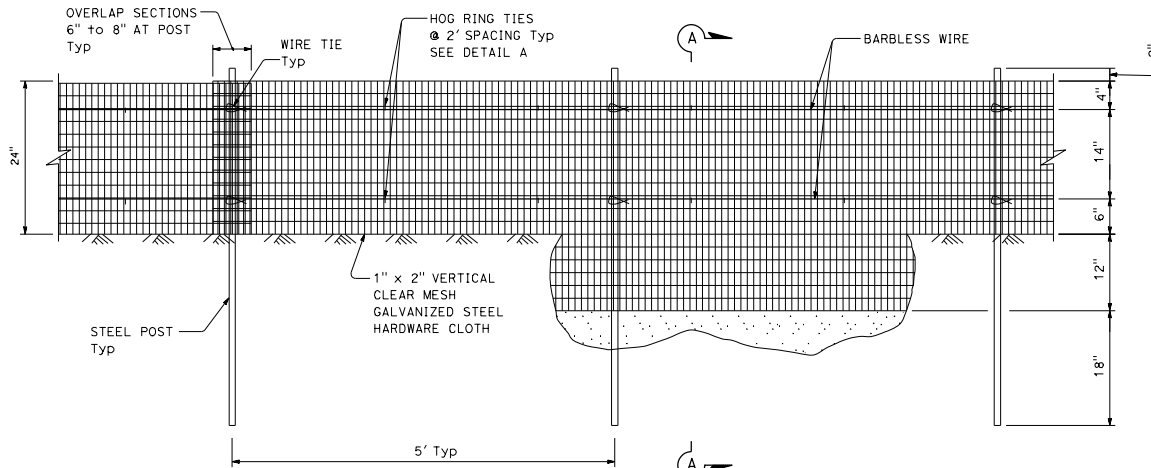

FRONT VIEW

LEGEND:

Desert Tortoise Habitat

NOTE:

1. Exact locations for desert tortoise fence are shown on the plans.

DIST	COUNTY	ROUTE	POST MILES TOTAL PROJECT	SHEET TOTAL SHEETS

Raymond Don Jester
 REGISTERED CIVIL ENGINEER
 No. C37332
 July 15, 2016
 PLANS APPROVAL DATE
THE STATE OF CALIFORNIA OR ITS OFFICERS OR AGENTS SHALL NOT BE RESPONSIBLE FOR THE ACCURACY OR COMPLETENESS OF SCANNED COPIES OF THIS PLAN SHEET.

TO ACCOMPANY PLANS DATED _____

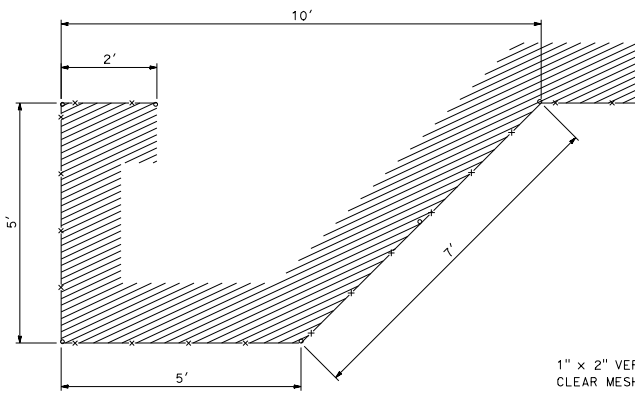

REDIRECTIONAL CONFIGURATION PLAN VIEW

U-SHAPED HOLD DOWN PINS
6" LONG (24" Max SPACING)

DETAIL B

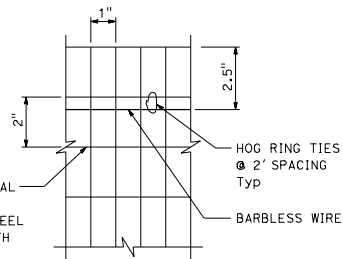

DETAIL A

OVERLAP SECTIONS
6" to 8" AT POST
Typ

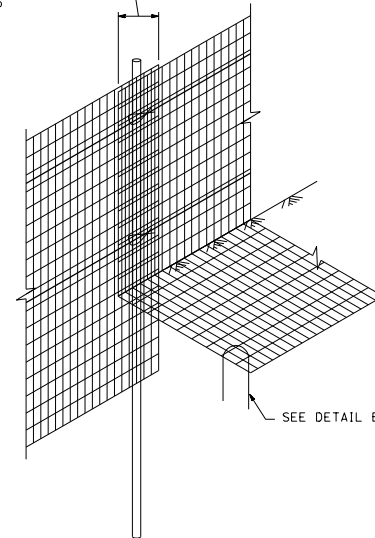

**FENCE TRANSITION FOR
BEDROCK OR CALICHE SUBSTRATE**

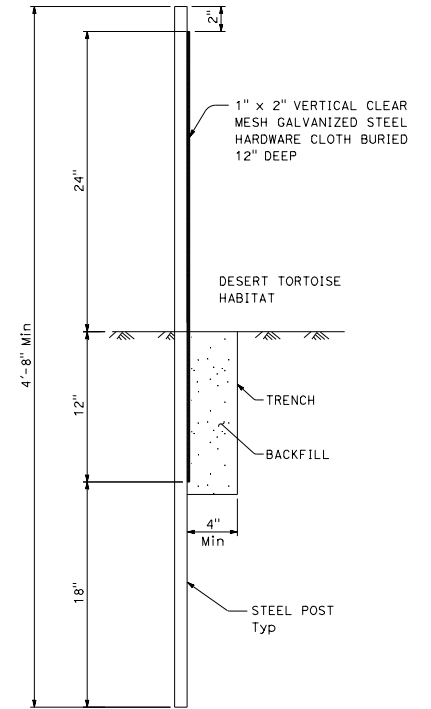

SECTION A-A

DESERT TORTOISE FENCE

STATE OF CALIFORNIA
DEPARTMENT OF TRANSPORTATION

NO SCALE

RSP A84B DATED JULY 15, 2016 SUPPLEMENTS THE STANDARD PLANS BOOK DATED 2015.

REVISED STANDARD PLAN RSP A84B

2015 REVISED STANDARD PLAN RSP A84B

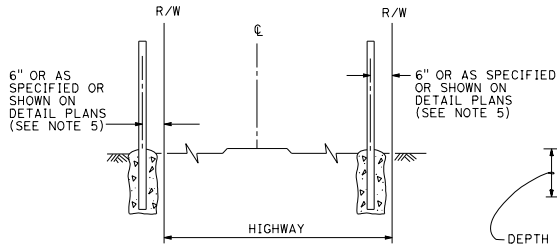

FENCE LOCATION

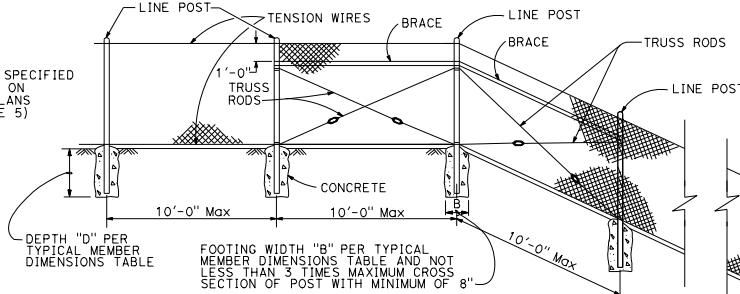

CHAIN LINK FENCE ON SHARP BREAK IN GRADE

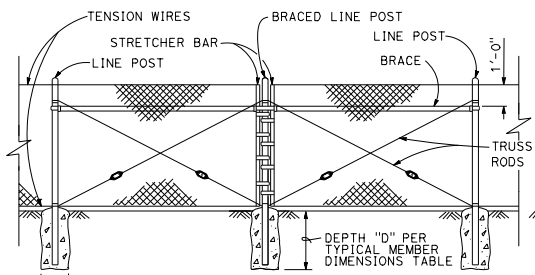
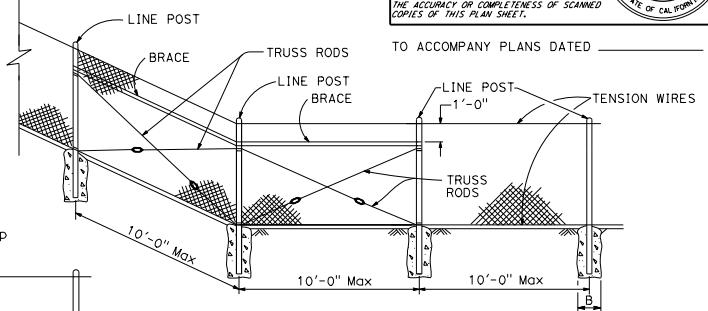

BRACED LINE POST INSTALLATION

Braced line post at intervals not exceeding 1000'

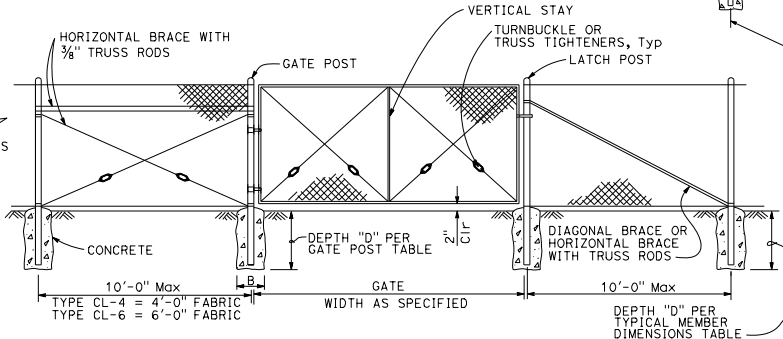

CHAIN LINK GATE INSTALLATION

Maximum Gate Width is 12'-0"
Vertical Stay is required in middle of gate greater than 8'-0" in width.

		GATE POST					
FENCE HEIGHT (Max)	SLATTED	B (in)	D (ft)	ROUND PIPE			
				SECTION	ROUND OD PIPE	WEIGHT (lb/ft)	
5'-0"	NO	12"	2'-6"	3 Std	3.50"	7.58	
6'-0"	NO	12"	2'-6"	3 Std	3.50"	7.58	
8'-0"	NO	12"	3'-0"	3 Std	3.50"	7.58	
10'-0"	NO	14"	3'-6"	3 Std	3.50"	7.58	
5'-0"	YES	12"	3'-0"	3 1/2 Std	4.00"	9.12	
6'-0"	YES	14"	3'-6"	4 Std	4.50"	10.80	
8'-0"	YES	18"	3'-6"	5 Std	5.56"	14.60	
10'-0"	YES	20"	4'-0"	6 Std	6.63"	19.00	

Above post dimensions and weights are minimums. Larger sizes may be used upon approval.

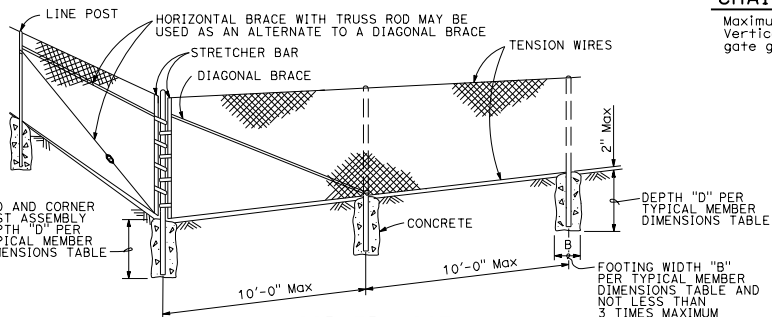

CORNER POST

NOTES:

- The table to the right shows minimum sized posts and braces complying with the specifications. Larger or heavier post and brace sizes may be used upon approval.
- Sections shown in the tables must also comply with the strength requirements and other provisions of the Specifications.
- Other sections which comply with the strength requirements and other provisions of the Specifications may be used upon approval.
- Options exercised shall be uniform on any one project.
- Offset to be 2'-0" at monument locations, measured at right angles to R/W lines. Taper to achieve offset to be at least 20'-0" long.
- See Standard Plan A85B for Brace, Stretcher Bar, and Truss Tightener Details.

TYPICAL MEMBER DIMENSIONS (See Notes)													
FENCE HEIGHT (Max)	SLATTED	B (in)	D (ft)	LINE POSTS				BRACES					
				ROUND PIPE		ROLL FORMED		ROUND PIPE		ROLL FORMED			
				SECTION	ROUND OD PIPE	SECTION	WEIGHT (lb/ft)	SECTION	ROUND OD PIPE	SECTION	WEIGHT (lb/ft)		
5'-0"	NO	8"	2'-6"	1 1/2 Std	1.90"	2.72	1.875" x 1.625"	1.85	1 1/2" Std	1.90"	2.72	1.625" x 1.250"	1.35
6'-0"	NO	10"	2'-6"	2 Std	2.38"	3.66	1.875" x 1.625"	2.40	2 Std	2.38"	3.66	1.625" x 1.250"	1.35
8'-0"	NO	12"	3'-0"	2 1/2 Std	2.88"	5.80	3.250" x 2.500"	4.50	2 Std	2.38"	3.66	1.625" x 1.250"	1.35
10'-0"	NO	14"	3'-6"	3 Std	3.50"	7.58	3.250" x 2.500"	4.50	2 1/2 Std	2.88"	5.80	1.625" x 1.250"	1.35
5'-0"	YES	12"	3'-0"	3 1/2 Std	4.00"	9.12	N/A	-	2 Std	2.38"	3.66	N/A	-
6'-0"	YES	14"	3'-0"	4 Std	4.50"	10.80	N/A	-	2 Std	2.38"	3.66	N/A	-
8'-0"	YES	18"	3'-6"	5 Std	5.56"	14.60	N/A	-	2 Std	2.38"	3.66	N/A	-
10'-0"	YES	20"	4'-0"	6 Std	6.63"	19.00	N/A	-	2 1/2 Std	2.88"	5.80	N/A	-

STATE OF CALIFORNIA
DEPARTMENT OF TRANSPORTATION

CHAIN LINK FENCE
NO SCALE

RSP A85 DATED JULY 21, 2017 SUPERSEDES RSP A85 DATED JANUARY 20, 2017 AND RSP A85 DATED JULY 15, 2016 AND STANDARD PLAN A85 DATED OCTOBER 30, 2015 - PAGE 117 OF THE STANDARD PLANS BOOK DATED 2015.

REVISED STANDARD PLAN RSP A85

2015 REVISED STANDARD PLAN RSP A85

DIST	COUNTY	ROUTE	POST MILES TOTAL PROJECT	SHEET TOTAL SHEETS

B. O. Zahedi
REGISTERED CIVIL ENGINEER
M. Reza Valizadeh
No. CS1902
PLANS APPROVAL DATE
July 21, 2017
EXP. 6-30-18
CIVIL
REGISTERED PROFESSIONAL ENGINEER
STATE OF CALIFORNIA

TO ACCOMPANY PLANS DATED _____

D16+	COUNTY	ROUTE	POST MILES TOTAL PROJECT	SHEET TOTAL SHEETS

B. O. Bennett
REGISTERED CIVIL ENGINEER

July 21, 2017
PLANS APPROVAL DATE

M. Reza Valizadeh
No. C51902
Exp. 6-30-18
CIVIL
STATE OF CALIFORNIA

THE STATE OF CALIFORNIA OR ITS OFFICERS OR AGENTS SHALL NOT BE RESPONSIBLE FOR THE ACCURACY OR COMPLETENESS OF SCANNED COPIES OF THIS PLAN SHEET.

NOTES:

1. B is not less than 3 times maximum cross section of post with minimum of 8".
2. See Revised Standard Plan RSP A85 for Chain Link Fencing dimensions.
3. See Detail A on Standard Plan A86B for connection at headwall.
4. See Detail D on Standard Plan A86B for connection at headwall.

CENTER POST		
FENCE HEIGHT (Max)	SLATTED	D
ALL HEIGHTS	NO	1'-6"
5'-0"	YES	3'-0"
6'-0"	YES	3'-0"
8'-0"	YES	3'-6"
10'-0"	YES	4'-0"

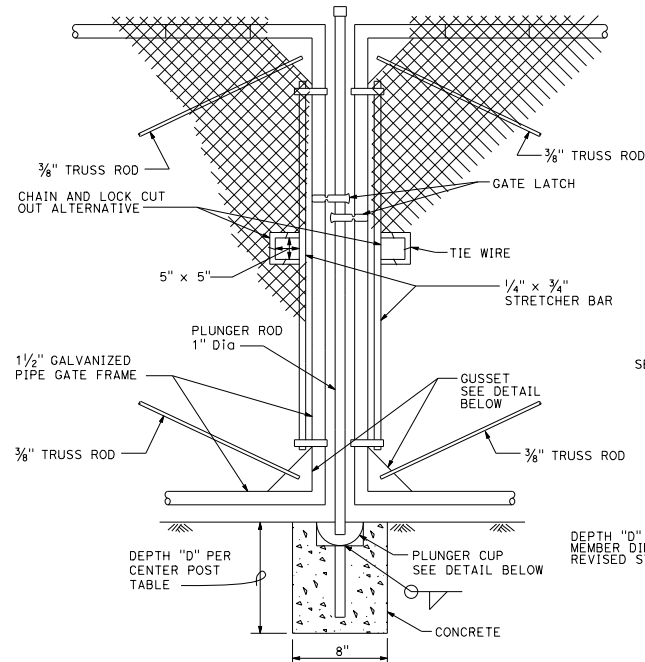

DOUBLE GATE REMOVABLE CENTER POST
Each gate maximum width is 12'-0"

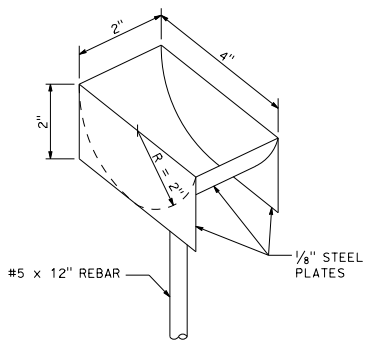

PLUNGER CUP DETAIL

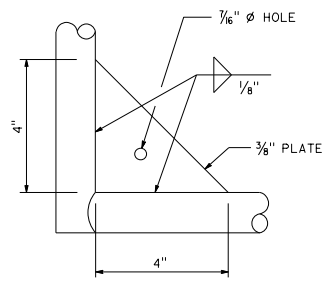

GUSSET DETAIL

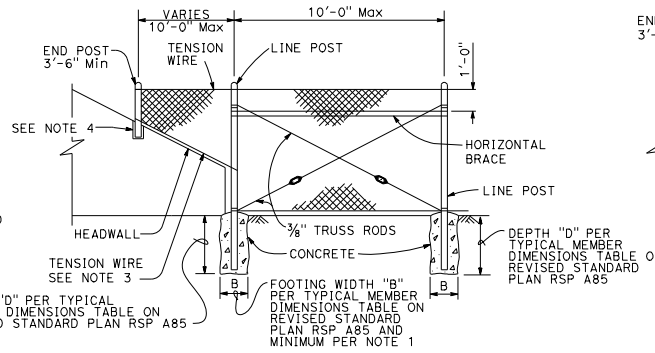

METHOD OF TYING FENCE TO HEADWALL

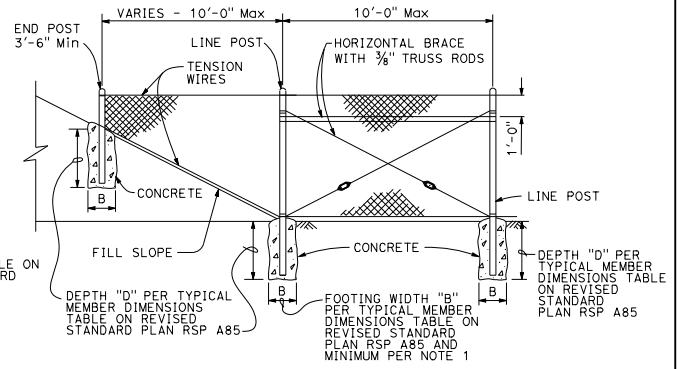

METHOD OF ERECTING FENCE FOR FILL SLOPE

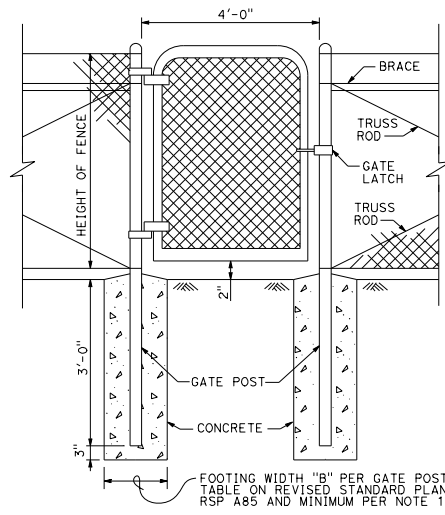

WALK GATE

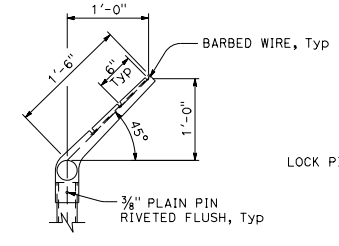

LINE POST

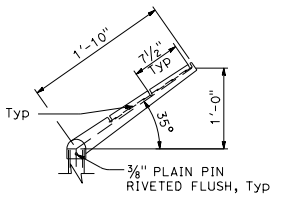

CORNER POST

BARBED WIRE POST TOP

STATE OF CALIFORNIA
DEPARTMENT OF TRANSPORTATION
CHAIN LINK FENCE DETAILS
NO SCALE

RSP A85A DATED JULY 21, 2017 SUPERSEDES RSP A85A DATED JANUARY 20, 2017 AND RSP A85A DATED JULY 15, 2016 AND STANDARD PLAN A85A DATED OCTOBER 30, 2015 - PAGE 118 OF THE STANDARD PLANS BOOK DATED 2015.

REVISED STANDARD PLAN RSP A85A

2015 REVISED STANDARD PLAN RSP A85A

DIST	COUNTY	ROUTE	POST MILES TOTAL PROJECT	SHEET TOTAL NO. SHEETS

 REGISTERED CIVIL ENGINEER
 January 15, 2016
 PLANS APPROVAL DATE
 No. 44788
 EXP. 3-31-16
 CIVIL
 STATE OF CALIFORNIA

THE STATE OF CALIFORNIA OR ITS OFFICERS OR AGENTS SHALL NOT BE RESPONSIBLE FOR THE ACCURACY OR COMPLETENESS OF SCANNED COPIES OF THIS PLAN SHEET.

TO ACCOMPANY PLANS DATED _____

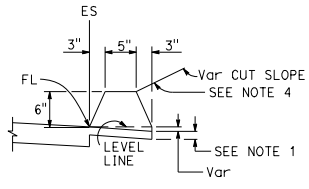

TYPE A

See Notes 3 and 5

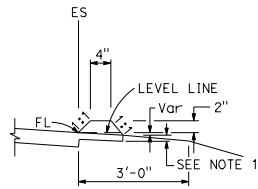

TYPE C

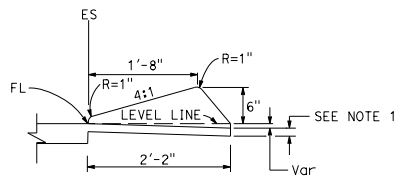

TYPE D

DIKES

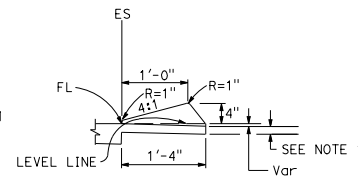

TYPE E

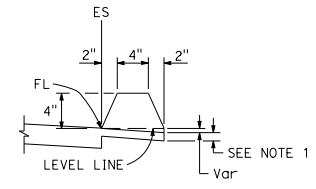

TYPE F

See Note 5

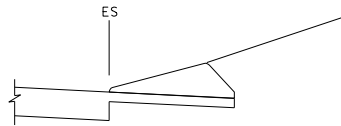

CASE C-1
Cut Slope

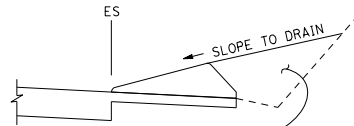

CASE C-2
Cut Slope

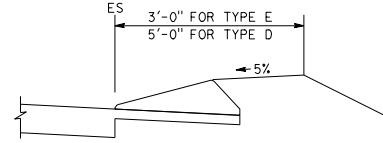

CASE F

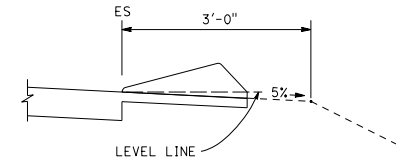

CASE R
See Note 2

TYPE D AND E BACKFILL DETAILS

NOTES:

- For HMA shoulders only, extend top layer of HMA placed on the shoulder under dike with no joint at the ES. For projects with OGFC shoulders, do not extend OGFC under dike. See project plans for modified dike detail.
- Case R applies to retrofit only projects where restrictive conditions do not provide enough width for Case F backfill.
- Type A dike only to be used where restrictive slope conditions do not provide enough width to use Type D or Type E dike.
- Fill and compact with excavated material to top of dike.
- Use Type A or F dike, where dike is required with guardrail installations. See Standard Plan A77N4 for dike positioning details. See Standard Plan A77N3 for hinge point offsets with guardrail.

DIKE QUANTITIES

TYPE	CUBIC YARDS PER LINEAR FOOT
A	0.0135
C	0.0038
D	0.0293
E	0.0130
F	0.0066

Quantities based on 5% cross slope.

STATE OF CALIFORNIA
DEPARTMENT OF TRANSPORTATION

HOT MIX ASPHALT DIKES

NO SCALE

RSP A87B DATED JANUARY 15, 2016 SUPERSEDES STANDARD PLAN A87B
DATED OCTOBER 30, 2015 - PAGE 126 OF THE STANDARD PLANS BOOK DATED 2015.

REVISED STANDARD PLAN RSP A87B

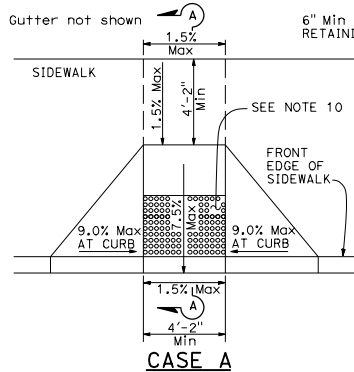

CASE A

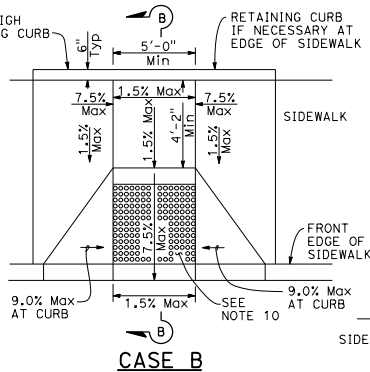

CASE B

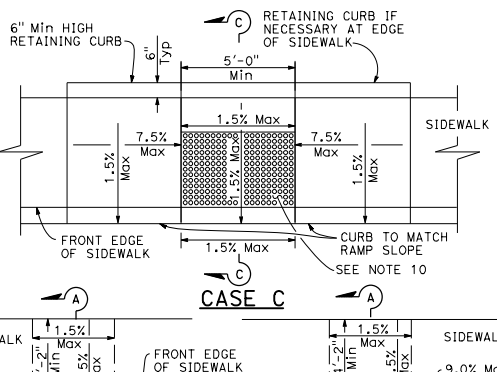

CASE C

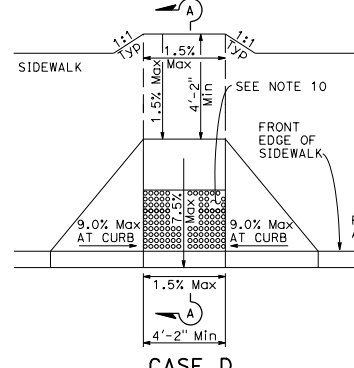

CASE D

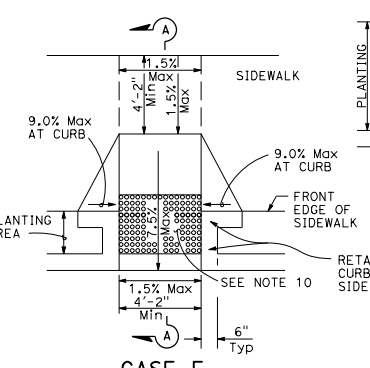

CASE E

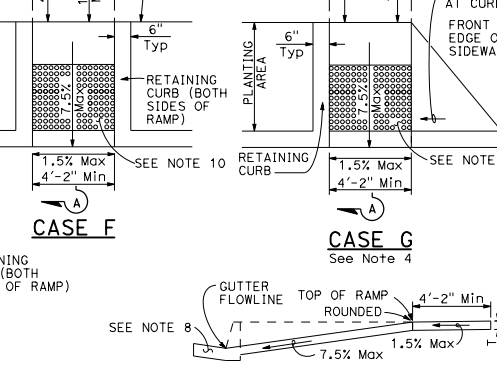

CASE F

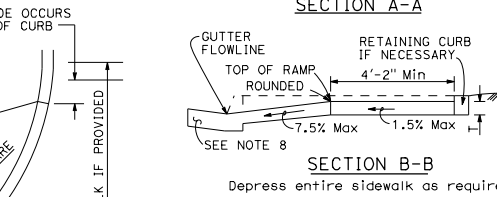

CASE G

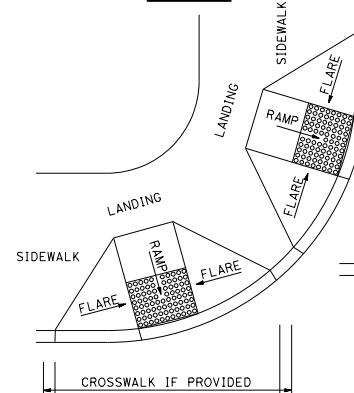

DETAIL A

TYPICAL TWO-RAMP CORNER INSTALLATION

See Note 1

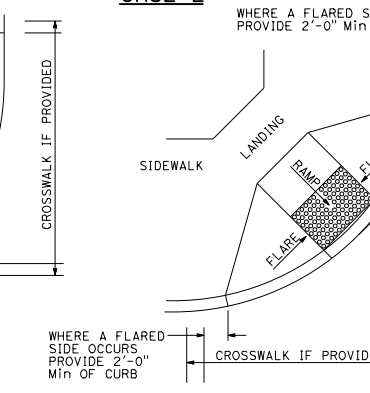

DETAIL B

TYPICAL ONE-RAMP CORNER INSTALLATION

See Notes 1 and 3

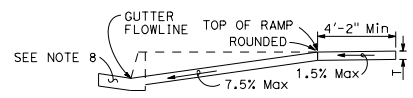

SECTION A-A

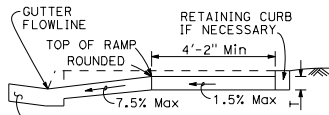

SECTION B-B

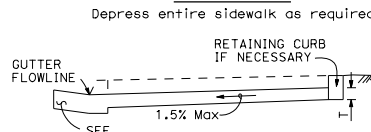

SECTION C-C

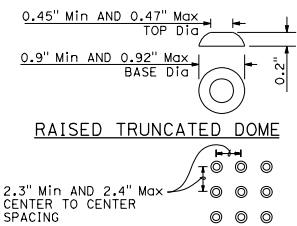

RAISED TRUNCATED DOME

RAISED TRUNCATED DOME PATTERN (IN-LINE)

DETECTABLE WARNING SURFACE

NOTES: See Note 10

- As site conditions dictate, Case A through Case G curb ramps may be used for corner installations similar to those shown in Detail A and Detail B. The case of curb ramps used in Detail A do not have to be the same. Case A through Case G curb ramps also may be used at mid block locations, as site conditions dictate. For specific site condition configuration, including the conform to existing sidewalk, see Project Plans.
- If distance from curb to back of sidewalk is too short to accommodate ramp and 4'-2" platform (landing) as shown in Case A, the sidewalk may be depressed longitudinally as in Case B or C or may be widened as in Case D.
- When ramp is located in center of curb return, crosswalk configuration must be similar to that shown for Detail B.
- As site conditions dictate, the retaining curb side and the flared side of the Case G ramp shall be constructed in reversed position.
- The ramp portion of the curb ramp is a typical rectangle, unless modified in the Project Plans.
- Side slope of ramp flares vary uniformly from a maximum of 9.0% at curb to conform with longitudinal sidewalk slope adjacent to top of the ramp, except in Case C and Case F.
- The adjacent surfaces at transitions at curb ramps to walks, gutters, and streets shall be at the same level.
- Counter slopes of adjoining gutters and road surfaces immediately adjacent to and within 24 inches of the curb ramp shall not be steeper than 1:20H (5.0%). Gutter pan slope shall not exceed 1" of depth for each 2'-0" of width.
- Transition gutter pan slope from 1" of depth for each 2'-0" of width to match typical gutter pan slope per Standard Plan A87A.
- The detectable warning surface will be a rectangle as shown at back of curb, unless modified in the Project Plans. Curb ramps shall have a detectable warning surface that extends the full width and 3'-0" depth of the ramp. Detectable warning surfaces shall extend the full width of the ramp except a maximum gap of 1 inch is allowed on each side of the ramp. Detectable warning surfaces shall conform to the requirements in the Standard Specifications.
- Sidewalk and ramp thickness, "T", shall be 3/2" minimum.
- Utility pull boxes, manholes, vaults and all other utility facilities within the boundaries of the curb ramp will be relocated or adjusted to grade by the owner prior to, or in conjunction with, curb ramp construction.
- Detectable warning surface may have to be cut to allow removal of utility covers while maintaining detectable warning width and depth.

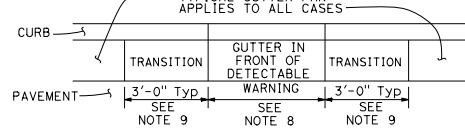

GUTTER PAN TRANSITION

STATE OF CALIFORNIA
DEPARTMENT OF TRANSPORTATION

CURB RAMP DETAILS

NO SCALE

RSP A88A DATED JULY 21, 2017 SUPERSEDES RSP A88A DATED JULY 15, 2016 AND STANDARD PLAN A88A DATED OCTOBER 30, 2015 - PAGE 127 OF THE STANDARD PLANS BOOK DATED 2015.

REVISED STANDARD PLAN RSP A88A

DIST	COUNTY	ROUTE	POST MILES TOTAL PROJECT	SHEET NO.	TOTAL SHEETS

REGISTERED CIVIL ENGINEER
 No. C41957
 Exp. 3-31-18
 CIVIL
 STATE OF CALIFORNIA

July 21, 2017
 PLANS APPROVAL DATE
 THE STATE OF CALIFORNIA OR ITS OFFICERS OR AGENTS SHALL NOT BE RESPONSIBLE FOR THE ACCURACY OR COMPLETENESS OF SCANNED COPIES OF THIS PLAN SHEET.

TO ACCOMPANY PLANS DATED _____

2015 REVISED STANDARD PLAN RSP A88A

Gutter not shown

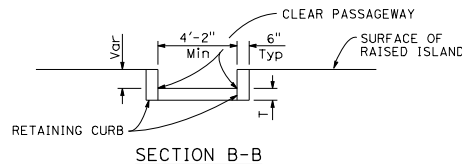
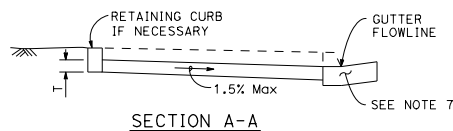
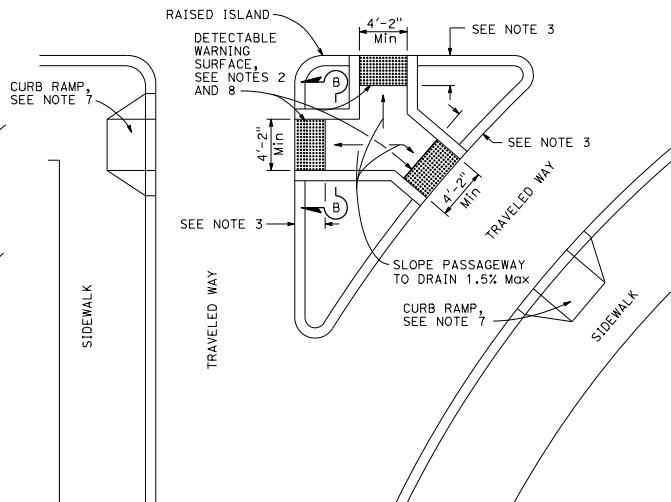
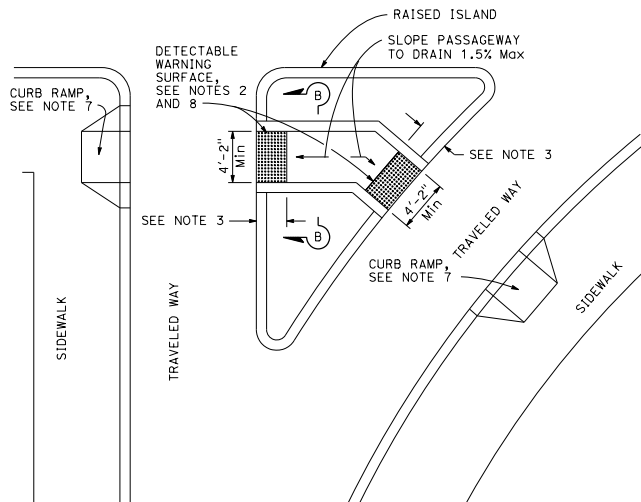
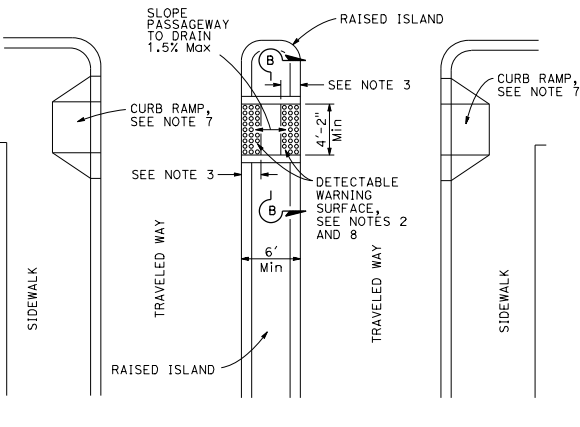
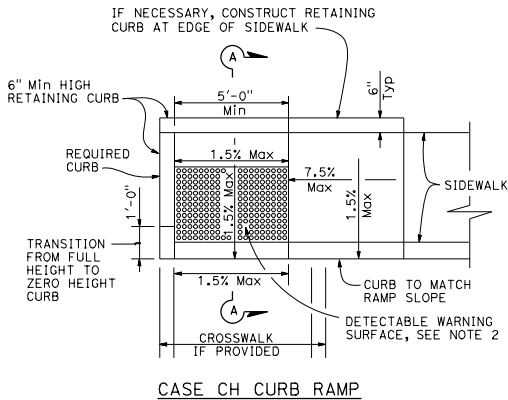
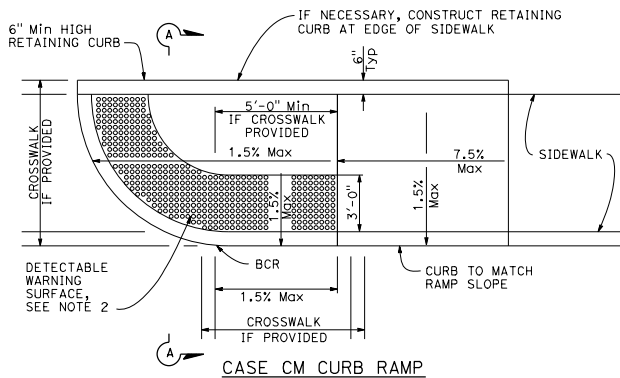

NOTES:

1. Sidewalk, ramp and passageway thickness, "T", shall be 3/2" minimum.
2. For details of detectable warning surfaces, see Revised Standard Plan RSP A88A.
3. Where an island passageway length is greater than or equal to 6'-0", but less than 8'-0", each detectable warning surface shall extend the full width and 2'-0" depth of the passageway length. Where an island passageway length is greater than or equal to 8'-0", each detectable warning surface shall extend the full width and 3'-0" depth of the passageway length. Detectable warning surfaces shall extend the full width of the island passageway except a maximum gap of 1 inch is allowed on each side of the passageway.
4. The adjacent surfaces at transitions at curb ramps to walks, gutters, and streets shall be at the same level.
5. Utility pull boxes, manholes, vaults and all other utility facilities within the boundaries of the curb ramp will be relocated or adjusted to grade by the owner prior to, or in conjunction with, curb ramp construction.
6. Detectable warning surface may have to be cut to allow removal of utility covers while maintaining detectable warning width and depth.
7. For additional curb ramp details, see Revised Standard Plan RSP A88A.
8. The detectable warning surface will be a rectangle as shown at the face of curb, unless modified in the Project Plans.

DIST	COUNTY	ROUTE	POST MILES TOTAL PROJECT	SHEET TOTAL SHEETS

Hector David Cordova
 REGISTERED CIVIL ENGINEER
 No. C41957
 Exp. 3-31-18
 CIVIL
 STATE OF CALIFORNIA

July 21, 2017
 PLANS APPROVAL DATE
 THE STATE OF CALIFORNIA OR ITS OFFICERS OR AGENTS SHALL NOT BE RESPONSIBLE FOR THE ACCURACY OR COMPLETENESS OF SCANNED COPIES OF THIS PLAN SHEET.

TO ACCOMPANY PLANS DATED _____

STATE OF CALIFORNIA
DEPARTMENT OF TRANSPORTATION
CURB RAMP AND ISLAND PASSAGEWAY DETAILS
NO SCALE

RSP A88B DATED JULY 21, 2017 SUPERSEDES RSP A88B DATED JULY 15, 2016 AND STANDARD PLAN A88B DATED OCTOBER 30, 2015 - PAGE 128 OF THE STANDARD PLANS BOOK DATED 2015.
REVISED STANDARD PLAN RSP A88B

2015 REVISED STANDARD PLAN RSP A88B

DIST	COUNTY	ROUTE	POST MILES TOTAL PROJECT	SHEET TOTAL SHEETS

H. David Cordova
REGISTERED CIVIL ENGINEER
No. C41957
Exp. 3-31-18
STATE OF CALIFORNIA

July 21, 2017
PLANS APPROVAL DATE

THE STATE OF CALIFORNIA OR ITS OFFICERS OR AGENTS SHALL NOT BE RESPONSIBLE FOR THE ACCURACY OR COMPLETENESS OF SCANNED COPIES OF THIS PLAN SHEET.

TO ACCOMPANY PLANS DATED _____

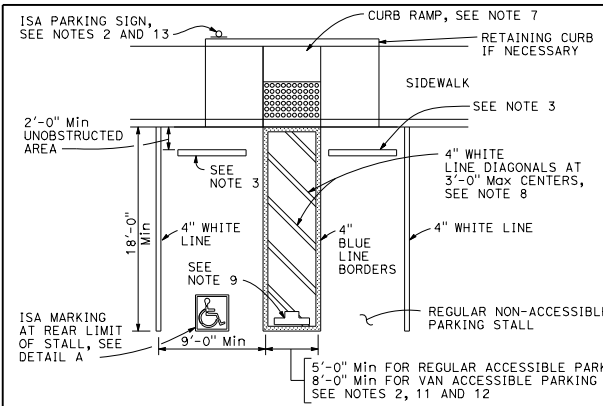

SINGLE PARKING STALL

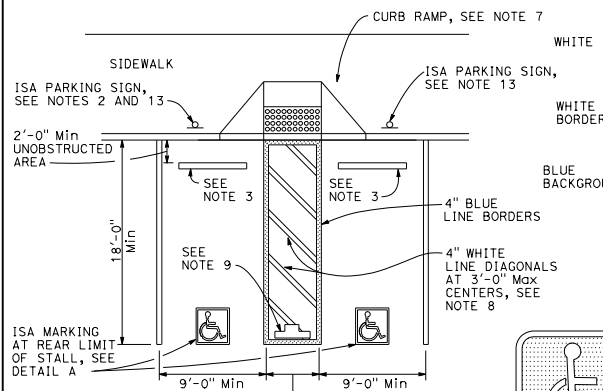

DOUBLE PARKING STALL

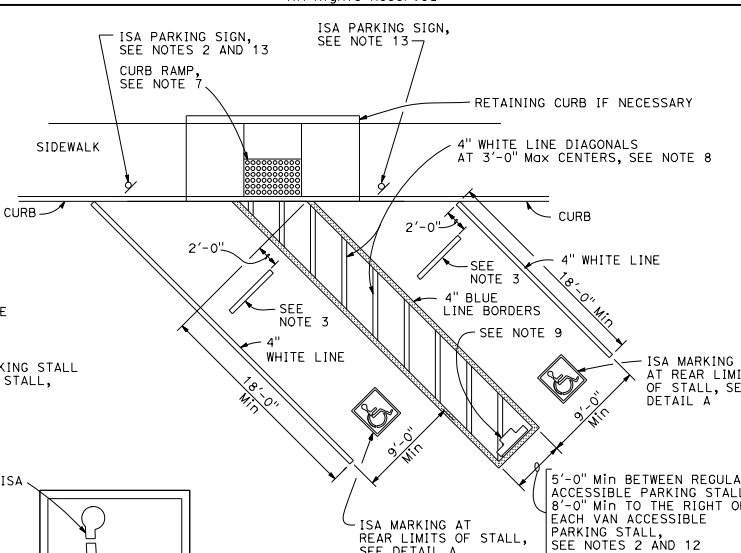

DIAGONAL DOUBLE PARKING STALLS

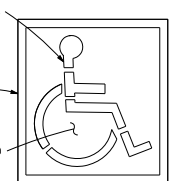

ISA MARKING
See Standard Plan A24C

DETAIL A

TABLE A

TOTAL NUMBER OF PARKING SPACES PROVIDED IN PARKING FACILITY	MINIMUM NUMBER OF REQUIRED ACCESSIBLE PARKING SPACES
1-25	1
26-50	2
51-75	3
76-100	4
101-150	5
151-200	6
201-300	7
301-400	8
401-500	9
501-1000	2 PERCENT OF TOTAL
1001 AND OVER	20 PLUS 1 FOR EACH 100 OR FRACTION THEREOF OVER 1000



SIGN R99 (CA)



SIGN R99C (CA)
See Note 6



PLAQUE R99B (CA)

SIGN R99 (CA) with PLAQUE R99B (CA)
See Note 6



SIGN R100B (CA)
See Note 10



SIGN R7-8b
See Notes 2 and 6

NOTES:

1. Accessible parking spaces serving a particular building shall be located on the shortest accessible route of travel from adjacent parking to an accessible entrance. In parking facilities that do not serve a particular building, accessible parking shall be located on the shortest accessible route of travel to an accessible pedestrian entrance of the parking facility.
2. One in every six accessible off-street parking stalls, but not less than one, shall be served by an accessible aisle of 8'-0" minimum width and shall be signed van accessible. The R7-8b sign shall be mounted below the R99B (CA) plaque or the R99C (CA) sign.
3. In each parking stall, a curb or parking bumper shall be provided if required to prevent encroachment of vehicles over the required width of walkways. Parking stalls shall be so located that persons with disabilities are not compelled to wheel or walk behind parked vehicles other than their own. For more parking bumper requirements, see the Standard Specifications.
4. Parking spaces and access aisles shall be level with surface slopes not exceeding 1.5% in all directions.
5. Table A shall be used to determine the required number of accessible parking stalls in each parking lot or garage.
6. Where Plaque R99B (CA), Sign R99C (CA) or Sign R7-8b are installed, the bottom of the sign or plaque panel shall be a minimum of 7'-0" above the surrounding surface.
7. Curb ramps shall conform to the details shown on Revised Standard Plan RSP A88A.
8. Blue paint, instead of white may be used for marking accessibility aisles in areas where snow may cause white markings to not be visible.
9. The words "NO PARKING", shall be painted in white letters no less than 1'-0" high and located so that it is visible to traffic enforcement officials. See Standard Plan A90B for details of the "NO PARKING" pavement marking.
10. A R100B (CA) sign shall be posted in a conspicuous place at each entrance to off-street parking facilities or immediately adjacent to and visible from each stall. The sign shall include the address where the towed vehicle may be reclaimed and the telephone number of the local traffic law enforcement agency.
11. Where a single (non-van) accessible parking space is provided, the loading and unloading access aisle shall be on the passenger side of the vehicle as the vehicle is going forward into the parking space.
12. Where a van accessible parking space is provided, the loading and unloading access aisle shall be 8'-0" wide minimum, and shall be on the passenger side of the vehicle as the vehicle is going forward into the parking space.
13. Accessible Parking Only Sign shall be Sign R99C (CA) or Sign R99 (CA) with Plaque R99B (CA).

LEGEND

ISA = International Symbol of Accessibility

STATE OF CALIFORNIA
DEPARTMENT OF TRANSPORTATION

**ACCESSIBLE PARKING
OFF-STREET**

NO SCALE

RSP A90A DATED JULY 21, 2017 SUPERSEDES STANDARD PLAN A90A
DATED OCTOBER 30, 2015 - PAGE 129 OF THE STANDARD PLANS BOOK DATED 2015.

REVISED STANDARD PLAN RSP A90A

OFF-STREET PARKING SIGNS

(Parking lot or garage)
See Note 6

2015 REVISED STANDARD PLAN RSP A90A

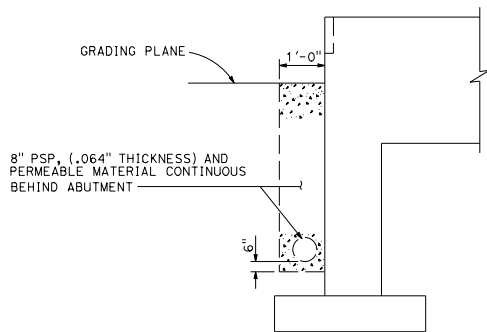

BRIDGE DETAIL 3-5
8" PSP AND PERMEABLE MATERIAL

* FOR PLACEMENT IN BRIDGE DECKS
SEE JOINT SEAL DETAILS. FOR WALL
THICKNESS LESS THAN 1'-0", USE 1/2
THE WALL THICKNESS.

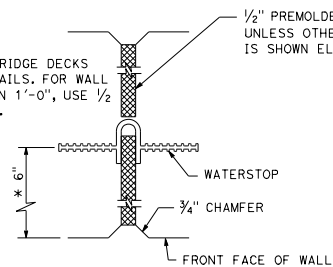

BRIDGE DETAIL 3-4
WALL EXPANSION JOINT

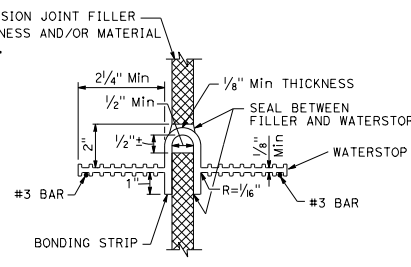

BRIDGE DETAIL 3-6
WATERSTOP

DIST	COUNTY	ROUTE	POST MILES TOTAL PROJECT	SHEET NO.	TOTAL SHEETS

Gary Wong
REGISTERED CIVIL ENGINEER

July 21, 2017
PLANS APPROVAL DATE

THE STATE OF CALIFORNIA OR ITS OFFICERS
OR AGENTS SHALL NOT BE RESPONSIBLE FOR
THE ACCURACY OR COMPLETENESS OF SCANNED
COPIES OF THIS PLAN SHEET.

REGISTERED PROFESSIONAL ENGINEER
No. CS8238
Exp. 6-30-18
CIVIL
STATE OF CALIFORNIA

TO ACCOMPANY PLANS DATED _____

NOTES:

- Holes will be permitted in the outer 1/2" of the web for wire, rings, etc. Tie web to #3 reinforcing bars @ 12 maximum intervals to support the waterstop in proper position during concrete placement. Alternative detail may be submitted for approval of the Engineer.
- Waterstop to have 5 or more pairs of raised ribs to provide 0.1 square inch minimum rib cross-section area on each half of the waterstop.

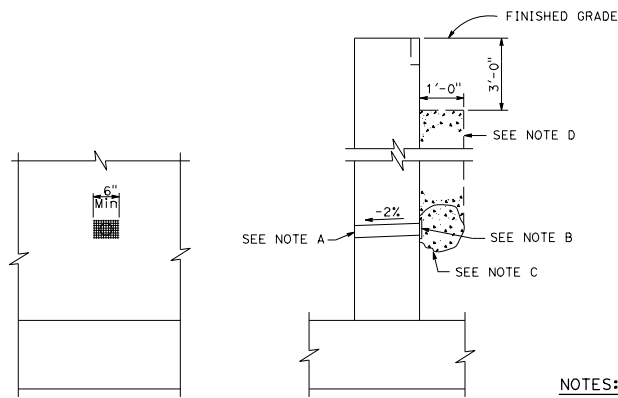

ELEVATION
SECTION
BRIDGE DETAIL 3-1
WEEP HOLE AND PERVIOUS BACKFILL

NOTES:

- 4" ϕ Drains @ 25'-0" maximum center to center. For walls adjacent to sidewalks or curbs, provide 4" plastic pipe under the sidewalk to discharge thru curb face. Exposed wall drains shall be located 3' \pm above finished grade.
- 6" square aluminum or galvanized steel wire 1/4" mesh hardware cloth, minimum wire diameter 0.025". Anchor firmly to backface.
- One cubic foot pervious backfill material in a nonwoven filter fabric, securely tied.
- Pervious backfill material continuous behind retaining wall or abutment.

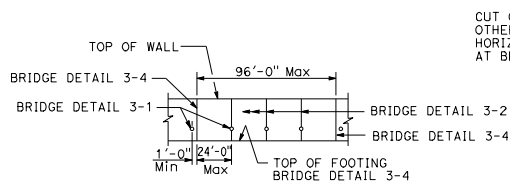

BRIDGE DETAIL 3-3
WALL EXPANSION JOINTS AND WEAKENED PLANES

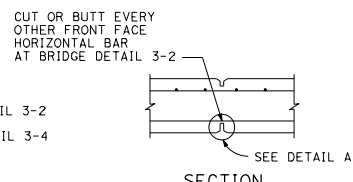

SECTION
BRIDGE DETAIL 3-2

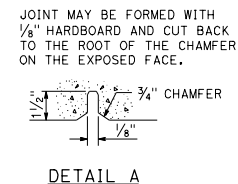

DETAIL A
BRIDGE DETAIL 3-2

WEAKENED PLANES

STATE OF CALIFORNIA
DEPARTMENT OF TRANSPORTATION
BRIDGE DETAILS
NO SCALE

RSP B0-3 DATED JULY 21, 2017 SUPERSEDES STANDARD PLAN B0-3
DATED OCTOBER 30, 2015 - PAGE 277 OF THE STANDARD PLANS BOOK DATED 2015.
REVISED STANDARD PLAN RSP B0-3

2015 REVISED STANDARD PLAN RSP B0-3

DIST	COUNTY	ROUTE	POST MILES TOTAL PROJECT	SHEET NO.	TOTAL SHEETS

Gary Wong
 REGISTERED CIVIL ENGINEER
 No. CS8298
 Exp. 6-30-18
 CIVIL
 STATE OF CALIFORNIA

July 21, 2017
 PLANS APPROVAL DATE
 THE STATE OF CALIFORNIA OR ITS OFFICERS OR AGENTS SHALL NOT BE RESPONSIBLE FOR THE ACCURACY OR COMPLETENESS OF SCANNED COPIES OF THIS PLAN SHEET.

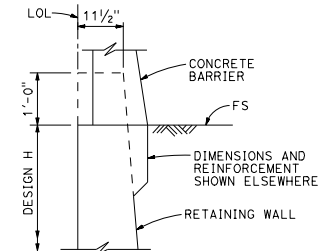
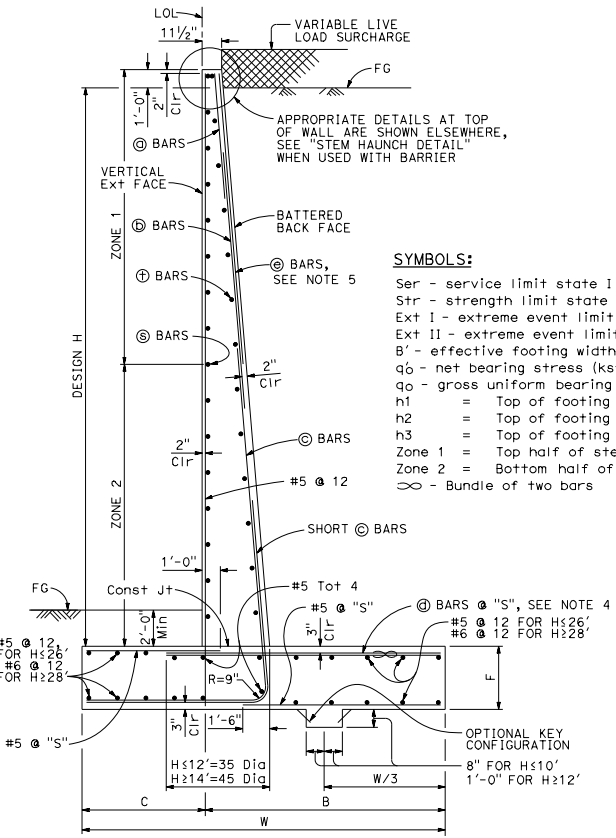

STEM HAUNCH DETAIL

DESIGN CONDITIONS:

Design H may be exceeded by 6" before going to the next size. Special footing design is required where foundation material is incapable of supporting bearing stress listed in the table.

SYMBOLS:

- Ser - service limit state I
- Str - strength limit state I
- Ext I - extreme event limit state I
- Ext II - extreme event limit state II
- B' - effective footing width (ft)
- q_o - net bearing stress (ksf), OG assumed to be FG at toe
- q_o - gross uniform bearing stress (ksf)
- h1 = Top of footing to top of short ⓐ bar
- h2 = Top of footing to top of ⓑ bar
- h3 = Top of footing to top of ⓒ bar
- Zone 1 = Top half of stem height
- Zone 2 = Bottom half of stem height
- ∞ - Bundle of two bars

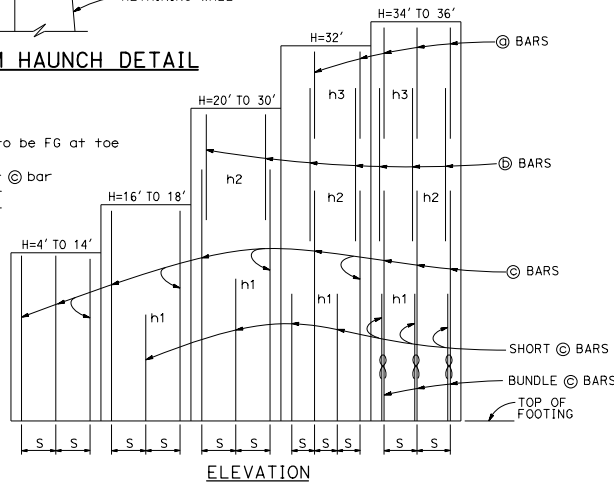

ELEVATION

DESIGN NOTES:

- TO ACCOMPANY PLANS DATED _____
- DESIGN: AASHTO LRFD Bridge Design Specifications, 4th Edition with California Amendments
- LS: Varied surcharge on level ground surface
- DC: Stem Architectural Treatment of thickness up to 6' of concrete (75 psf) considered
- CT: 54 kip transverse force applied at H_e = 32', distributed over 10 feet at the top of wall and 1:1 distribution down and outward. Distribution below footing taken no less than 40'.
- SEISMIC: k_h = 0.2, k_v = 0.0
- SOIL: φ = 34°, γ = 120 pcf
- REINFORCED CONCRETE: f'_c = 3,600 psi
f_y = 60,000 psi
- LOAD COMBINATIONS AND LIMIT STATES:
 Service I Q = 1.00DC+1.00EV+1.00EH+1.00LS
 Strength I Q = αDC+PEV+NEH+1.75LS
 Extreme I Q = 1.00DC+1.00EV+1.00EH+1.00EQD+1.00EQE
 Extreme II Q = 1.00DC+1.00EV+1.00EH+1.00CT
- Where:
 Q: Force Effects
 α: 1.25 or 0.90, Whichever Controls Design
 β: 1.35 or 1.00, Whichever Controls Design
 η: 1.50 or 0.90, Whichever Controls Design
 DC: Dead Load of Structure Components
 EH: Horizontal Earth Fill Pressure
 EV: Vertical Earth Pressure from Earth Fill Weight
 LS: Live Load Surcharge
 EQE: Seismic Earth Pressure
 EQD: Soil and Structural and Nonstructural Components Inertia
 CT: Vehicular Collision Force

TABLE OF REINFORCING STEEL, DIMENSIONS AND DATA

DESIGN H	4'	6'	8'	10'	12'	14'	16'	18'	20'	22'	24'	26'	28'	30'	32'	34'	36'
W	6'-10"	7'-0"	7'-3"	7'-7"	8'-4"	9'-7"	10'-9"	12'-0"	13'-3"	14'-6"	15'-9"	17'-1"	18'-5"	19'-10"	21'-2"	22'-7"	24'-0"
C	2'-2"	2'-3"	2'-3"	2'-4"	2'-6"	3'-0"	3'-6"	4'-0"	4'-6"	5'-0"	5'-5"	6'-0"	6'-6"	7'-2"	7'-8"	8'-2"	9'-0"
B	4'-8"	4'-9"	5'-0"	5'-3"	5'-10"	6'-7"	7'-3"	8'-0"	8'-9"	9'-6"	10'-4"	11'-1"	11'-11"	12'-8"	13'-6"	14'-5"	15'-0"
F	1'-4"	1'-4"	1'-4"	1'-4"	1'-6"	1'-8"	1'-8"	1'-9"	1'-9"	1'-11"	2'-2"	2'-5"	2'-10"	3'-3"	3'-6"	4'-0"	4'-3"
BATTER	1/2:12	1/2:12	1/2:12	1/2:12	1/2:12	1/2:12	1/2:12	1/2:12	1/2:12	1/2:12	5/8:12	5/8:12	3/4:12	3/4:12	1:12	1:12	1:12
SPACING "S"	9"	9"	9"	9"	9"	9"	6"	6"	6"	6"	6"	6"	6"	6"	6"	6"	8"
ⓐ BARS	-	-	-	-	-	-	-	-	-	-	-	-	-	-	-	#7	#6
ⓑ BARS	-	-	-	-	-	-	-	-	#7	#7	#7	#7	#7	#7	#7	#9	#8
ⓒ BARS	#6	#6	#6	#6	#6	#6	#7	#8	#8	#9	#9	#10	#10	#10	#11	#11	#11
ⓓ BARS	#5	#5	#6	#6	#6	#6	#7	#8	#8	#9	#9	#10	#10	#10	#11	#11	#11
h1	-	-	-	-	-	-	5'-9"	5'-10"	8'-0"	9'-0"	10'-1"	11'-0"	12'-1"	13'-0"	13'-0"	12'-7"	11'-6"
h2	-	-	-	-	-	-	-	-	10'-5"	13'-0"	14'-7"	17'-6"	19'-0"	20'-5"	19'-0"	18'-0"	20'-2"
h3	-	-	-	-	-	-	-	-	-	-	-	-	-	21'-2"	21'-10"	24'-0"	-
ZONE 1 ⓐ BARS	#5 @ 18	#5 @ 18	#5 @ 18	#5 @ 18	#5 @ 18	#5 @ 18	#5 @ 18	#5 @ 18	#5 @ 18	#5 @ 18	#5 @ 12	#5 @ 12	#5 @ 12	#5 @ 12	#5 @ 12	#5 @ 12	#5 @ 12
ZONE 2 ⓐ BARS	#5 @ 18	#5 @ 18	#5 @ 18	#5 @ 18	#5 @ 18	#5 @ 18	#5 @ 18	#5 @ 18	#5 @ 12	#5 @ 12	#5 @ 12	#5 @ 12	#5 @ 12	#6 @ 12	#6 @ 12	#7 @ 12	#7 @ 12
ZONE 1 ⓑ BARS	#4 @ 18	#4 @ 18	#4 @ 18	#4 @ 18	#4 @ 18	#4 @ 18	#4 @ 18	#4 @ 18	#4 @ 18	#4 @ 18	#4 @ 18	#4 @ 18	#4 @ 18	#4 @ 18	#4 @ 18	#4 @ 18	#4 @ 18
ZONE 2 ⓑ BARS	#4 @ 18	#4 @ 18	#4 @ 18	#4 @ 18	#4 @ 18	#4 @ 18	#4 @ 18	#4 @ 18	#4 @ 18	#4 @ 18	#4 @ 18	#4 @ 18	#4 @ 18	#4 @ 18	#4 @ 18	#4 @ 18	#4 @ 18
ZONE 1 ⓒ BARS	#4 @ 18	#4 @ 18	#4 @ 18	#4 @ 18	#4 @ 18	#4 @ 18	#4 @ 18	#4 @ 18	#4 @ 18	#4 @ 18	#4 @ 18	#4 @ 18	#4 @ 18	#4 @ 18	#4 @ 18	#4 @ 18	#4 @ 18
ZONE 2 ⓒ BARS	#4 @ 18	#4 @ 18	#4 @ 18	#4 @ 18	#4 @ 18	#4 @ 18	#4 @ 18	#4 @ 18	#4 @ 18	#4 @ 18	#4 @ 18	#4 @ 18	#4 @ 18	#4 @ 18	#4 @ 18	#4 @ 18	#4 @ 18
Ser: B', q _o	6.8, 0.7	6.5, 1.0	6.2, 1.3	6.0, 1.6	6.3, 2.0	7.5, 2.1	8.6, 2.2	9.8, 2.3	11.0, 2.4	12.1, 2.5	13.2, 2.8	14.4, 2.9	15.5, 3.1	16.8, 3.3	18.0, 3.5	19.2, 3.7	20.6, 3.7
Str: B', q _o	6.6, 1.6	5.0, 1.8	3.6, 2.3	3.0, 3.3	3.2, 4.0	4.3, 3.8	5.3, 3.7	6.4, 3.7	7.4, 3.8	8.2, 4.1	9.0, 4.4	9.9, 4.6	10.7, 4.9	11.7, 5.2	12.6, 5.4	13.6, 5.8	14.6, 5.9
Ext I: B', q _o	5.2, 1.1	4.7, 1.5	3.9, 2.2	3.1, 3.4	2.8, 4.8	3.2, 5.3	3.6, 5.7	4.1, 6.1	4.6, 6.4	5.0, 6.9	5.3, 7.6	5.8, 8.1	6.1, 8.9	6.7, 9.4	7.1, 10.0	7.5, 10.7	8.2, 10.9
Ext II: B', q _o	2.6, 2.2	2.7, 2.6	2.8, 3.1	2.9, 3.6	3.7, 3.6	5.2, 3.3	6.7, 3.1	8.3, 3.0	9.8, 3.0	11.2, 3.1	12.5, 3.2	13.9, 3.4	15.2, 3.6	16.7, 3.8	18.0, 4.0	19.3, 4.2	20.8, 4.3

NOTES:

- For details not shown and drainage notes see (B3-5)
- For wall stem joint details see (B0-3/3-3) and (B0-3/3-4)
- At ⓐ bars:
 H < 6', no splices are allowed within 1'-8" above the top of footing.
 H > 6', no splices are allowed within H/4 above the top of footing.
- Bundle ⓐ bars for H = 34' & 36'.
- Provide #6 @ 10" x 16'-0" ⓐ bars over a distance of 8'-0" measured from all expansion joints, begin wall and end wall locations. For H ≤ 14', hook ⓐ bar into footing and reduce bar length as needed to maintain Min Clr cover.

STATE OF CALIFORNIA
DEPARTMENT OF TRANSPORTATION
RETAINING WALL TYPE 1 (CASE 1)
NO SCALE

RSP B3-1A DATED JULY 21, 2017, SUPERSEDES STANDARD PLAN B3-1A
DATED OCTOBER 30, 2015 - PAGE 286 OF THE STANDARD PLANS BOOK DATED 2015.
REVISED STANDARD PLAN RSP B3-1A

2015 REVISED STANDARD PLAN RSP B3-1A

DESIGN CONDITIONS:

Design H may be exceeded by 6" before going to the next size. Special footing design is required where foundation material is incapable of supporting bearing stress listed in the table.

DESIGN NOTES:

- DESIGN: AASHTO LRFD Bridge Design Specifications, 4th Edition with California Amendments
- LS: Varied surcharge on level ground surface
- DC: Stem Architectural Treatment of thickness up to 6' of concrete (75 psf) considered
- SEISMIC: $k_h = 0.2$
 $k_v = 0.0$
- SOIL: $\phi = 34^\circ$
 $\gamma = 120$ pcf
- REINFORCED CONCRETE: $f'_c = 3,600$ psi
 $f_y = 60,000$ psi
- LOAD COMBINATIONS AND LIMIT STATES:
Service I $Q = 1.00DC + 1.00EV + 1.00EH + 1.00LS$
Strength I $Q = \alpha DC + \beta EV + \eta EH + 1.75LS$
Extreme I $Q = 1.00DC + 1.00EV + 1.00EH + 1.00EQD + 1.00EQE$
- Where:
Q: Force Effects
α: 1.25 or 0.90, Whichever Controls Design
β: 1.35 or 1.00, Whichever Controls Design
η: 1.50 or 0.90, Whichever Controls Design
DC: Dead Load of Structure Components
EH: Horizontal Earth Fill Pressure
EV: Vertical Earth Pressure from Earth Fill Weight
LS: Live Load Surcharge
EQE: Seismic Earth Pressure
EQD: Soil and Structural and Nonstructural Components Inertia

SYMBOLS:

- TO ACCOMPANY PLANS DATED _____
- Ser - service limit state I
Str - strength limit state I
Ext - extreme event limit state I
B' - effective footing width (ft)
 q_0 - net bearing stress (ksf), OG assumed to be FG at toe
 q_0 - gross uniform bearing stress (ksf)
h1 = Top of footing to top of short @ bar
h2 = Top of footing to top of @ bar
h3 = Top of footing to top of @ bar
h4 = Top of footing to top of @ bar
Zone 1 = Top half of stem height
Zone 2 = Bottom half of stem height
∞ - Bundle of two bars

DIST	COUNTY	ROUTE	POST MILES TOTAL PROJECT	SHEET NO.	TOTAL SHEETS

July 21, 2017
PLANS APPROVAL DATE

REGISTERED CIVIL ENGINEER
GARY WONG
No. C58298
Exp. 6-30-18
CIVIL
STATE OF CALIFORNIA

REGISTERED PROFESSIONAL ENGINEER
GARY WONG
No. C58298
Exp. 6-30-18
CIVIL
STATE OF CALIFORNIA

THE STATE OF CALIFORNIA OR ITS OFFICERS OR AGENTS SHALL NOT BE RESPONSIBLE FOR THE ACCURACY OR COMPLETENESS OF SCANNED COPIES OF THIS PLAN SHEET.

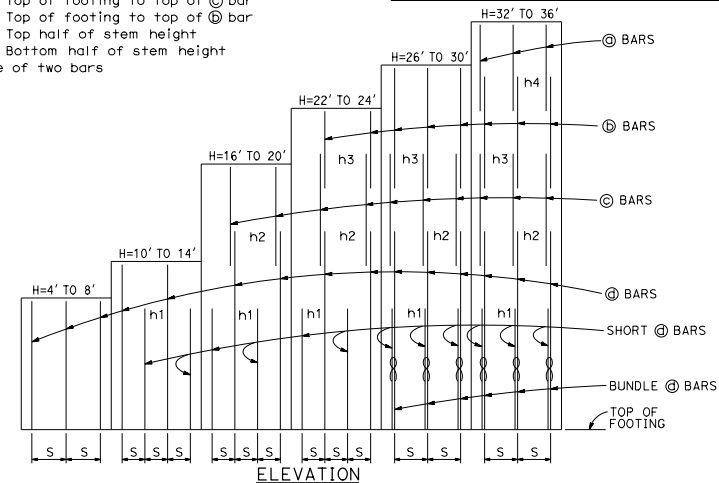
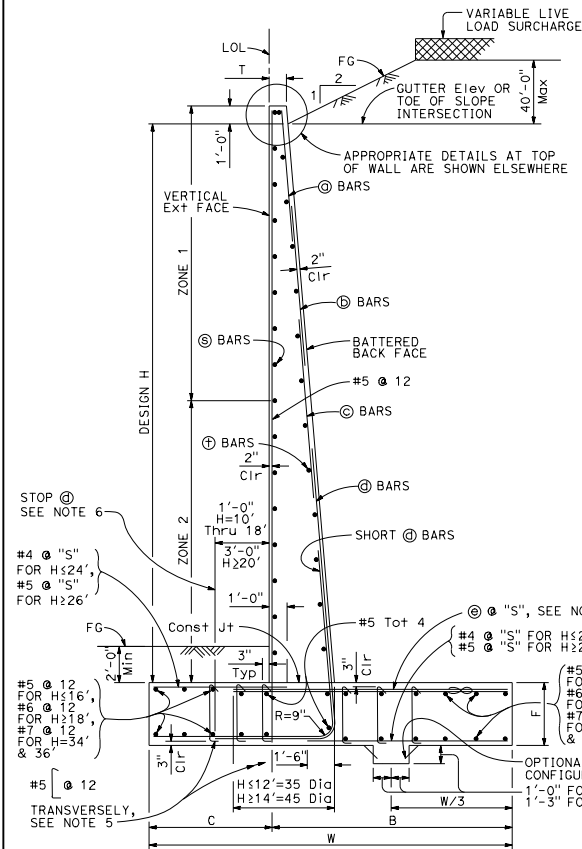

TABLE OF REINFORCING STEEL, DIMENSIONS AND DATA

DESIGN H	4'	6'	8'	10'	12'	14'	16'	18'	20'	22'	24'	26'	28'	30'	32'	34'	36'
W	6'-0"	7'-6"	9'-6"	11'-0"	12'-6"	15'-6"	17'-3"	19'-6"	21'-9"	23'-6"	26'-0"	28'-11"	30'-3"	31'-6"	33'-0"	34'-8"	35'-11"
C	2'-0"	2'-6"	3'-3"	3'-6"	4'-3"	5'-0"	5'-3"	5'-9"	6'-9"	7'-3"	8'-3"	8'-9"	9'-0"	9'-6"	10'-0"	10'-10"	11'-3"
B	4'-0"	5'-0"	6'-3"	7'-6"	8'-3"	10'-6"	12'-0"	13'-9"	15'-0"	16'-3"	17'-9"	19'-4"	21'-3"	22'-0"	23'-0"	23'-10"	24'-8"
F	1'-6"	1'-6"	2'-0"	2'-3"	2'-6"	2'-8"	2'-10"	3'-0"	3'-4"	3'-6"	3'-6"	3'-7"	3'-7"	3'-9"	3'-9"	4'-0"	4'-4"
T	11 1/2"	11 1/2"	11 1/2"	11 1/2"	11 1/2"	11 1/2"	11 1/2"	11 1/2"	11 1/2"	11 1/2"	11 1/2"	11 1/2"	11 1/2"	11 1/2"	11 1/2"	11 1/2"	11 1/2"
BATTER	1/2: 12	1/2: 12	1/2: 12	1/2: 12	1/2: 12	3/8: 12	3/8: 12	3/4: 12	3/4: 12	1: 12	1 1/8: 12	1 1/8: 12	1 1/8: 12	1 1/8: 12	1 1/8: 12	1 1/8: 12	1 1/8: 12
SPACING "S"	16"	12"	10"	7"	7"	7"	7"	7"	6"	6"	6"	6"	6"	6"	6"	6"	6"
@ BARS	-	-	-	-	-	-	-	-	-	-	-	-	-	-	-	-	-
∞ BARS	-	-	-	-	-	-	-	-	-	-	-	-	-	-	-	-	-
⊕ BARS	-	-	-	-	-	-	-	-	-	-	-	-	-	-	-	-	-
⊙ BARS	-	-	-	-	-	-	-	-	-	-	-	-	-	-	-	-	-
⊚ BARS	#5	#5	#6	#6	#7	#8	#9	#10	#10	#10	#11	#11	#11	#11	#11	#11	#11
⊛ BARS	#5	#5	#6	#6	#7	#8	#9	#10	#10	#10	#11	#11	#11	#11	#11	#11	#11
h1	-	-	-	5'-3"	6'-4"	7'-6"	8'-9"	9'-9"	11'-0"	11'-3"	11'-6"	10'-3"	11'-9"	12'-3"	12'-6"	13'-3"	13'-8"
h2	-	-	-	-	-	-	12'-8"	15'-6"	17'-0"	16'-6"	17'-3"	18'-0"	17'-6"	17'-4"	14'-10"	15'-9"	16'-4"
h3	-	-	-	-	-	-	-	-	-	18'-9"	21'-3"	21'-3"	22'-4"	22'-8"	18'-0"	18'-6"	19'-6"
h4	-	-	-	-	-	-	-	-	-	-	-	-	-	-	26'-3"	27'-4"	28'-6"
No. of Toe Stirrups	0	0	0	0	0	0	0	0	0	0	0	0	5	5	6	7	9
No. of Heel Stirrups	0	0	0	0	0	0	0	0	4	6	7	8	10	10	11	11	11
ZONE 1 @ BARS	#5 @ 18	#5 @ 18	#5 @ 18	#5 @ 18	#5 @ 18	#5 @ 18	#5 @ 18	#5 @ 18	#5 @ 12	#5 @ 12	#5 @ 12	#5 @ 12	#5 @ 12	#5 @ 12	#5 @ 12	#5 @ 12	#5 @ 12
ZONE 2 @ BARS	#5 @ 18	#5 @ 18	#5 @ 18	#5 @ 18	#5 @ 18	#5 @ 18	#5 @ 18	#5 @ 18	#5 @ 12	#5 @ 12	#5 @ 12	#5 @ 12	#5 @ 12	#5 @ 12	#5 @ 12	#5 @ 12	#5 @ 12
ZONE 1 ⊕ BARS	#4 @ 18	#4 @ 18	#4 @ 18	#4 @ 18	#4 @ 18	#4 @ 18	#4 @ 18	#4 @ 18	#4 @ 18	#4 @ 18	#4 @ 18	#4 @ 18	#4 @ 18	#4 @ 18	#4 @ 18	#4 @ 18	#4 @ 18
ZONE 2 ⊕ BARS	#4 @ 18	#4 @ 18	#4 @ 18	#4 @ 18	#4 @ 18	#4 @ 18	#4 @ 18	#4 @ 18	#4 @ 12	#4 @ 12	#4 @ 12	#4 @ 12	#4 @ 12	#4 @ 12	#4 @ 12	#4 @ 12	#4 @ 12
Ser: B', q ₀	4.0, 0.9	5.5, 1.0	9.3, 1.0	10.9, 1.3	12.3, 1.5	14.8, 1.9	16.6, 2.1	18.7, 2.4	20.6, 2.7	22.3, 3.0	24.2, 3.3	26.1, 3.5	28.2, 3.9	29.6, 4.0	31.1, 4.2	32.7, 4.4	34.1, 4.6
Str: B', q ₀	2.2, 2.2	3.5, 2.2	5.1, 2.3	6.3, 2.6	7.6, 2.7	12.9, 3.1	14.3, 3.6	16.5, 3.9	19.4, 4.5	20.7, 4.8	22.5, 5.2	24.3, 5.6	26.2, 6.0	27.5, 6.3	28.8, 6.6	30.3, 6.9	31.8, 7.2
Ext: B', q ₀	2.3, 3.4	2.7, 4.4	3.6, 5.0	3.8, 6.5	4.5, 7.0	7.0, 6.1	7.6, 6.9	9.3, 7.0	11.0, 7.1	11.8, 7.6	14.1, 7.4	15.6, 7.7	17.1, 8.0	17.2, 8.7	18.1, 9.0	19.0, 9.4	19.4, 10.0

NOTES:

TYPICAL SECTION

- For details not shown and drainage notes see B3-5
- For wall stem joint details see B0-3/3-3 and B0-3/3-4
- At @ and short @ bars:
H < 6', no splices are allowed within 1'-8" above the top of footing.
H > 6', no splices are allowed within H/4 above the top of footing.
- Bundle @ bars for H > 26'.
- Hook stirrups around & space with alternating transverse reinforcement at 2 x "S". For required number of toe or heel stirrup rows, see table. The first stirrups are placed adjacent to the stem as shown.
- Extend @ bars to end of toe for H=4' to 8'.

NO SCALE

REVISED STANDARD PLAN RSP B3-1B

STATE OF CALIFORNIA
DEPARTMENT OF TRANSPORTATION
RETAINING WALL TYPE 1 (CASE 2)
RSP B3-1B DATED JULY 21, 2017 SUPERSEDES STANDARD PLAN B3-1B
DATED OCTOBER 30, 2015 - PAGE 287 OF THE STANDARD PLANS BOOK DATED 2015.

2015 REVISED STANDARD PLAN RSP B3-1B

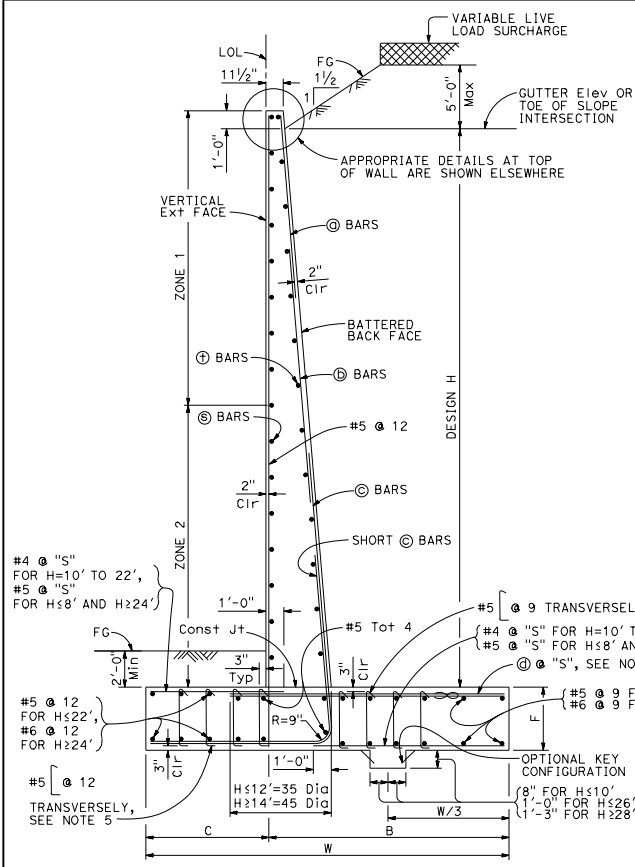

TYPICAL SECTION

NOTES:

- For details not shown and drainage notes see B3-5
- For wall stem joint details see B0-3 and B0-3
- At © bars:
H < 6', no splices are allowed within 1'-8" above the top of footing.
H > 6', no splices are allowed within H/4 above the top of footing.
- Bundle © bars for H = 36'.
- Hook stirrups around & space with alternating transverse reinforcement at 2 x "S". For required number of toe or heel stirrup rows, see table. The first stirrups are placed adjacent to the stem as shown.

DESIGN CONDITIONS:

Design H may be exceeded by 6" before going to the next size. Special footing design is required where foundation material is incapable of supporting bearing stress listed in the table.

DESIGN NOTES:

DESIGN: AASHTO LRFD Bridge Design Specifications, 4th Edition with California Amendments
LS: Varied surcharge on level ground surface
DC: Stem Architectural Treatment of thickness up to 6' of concrete (75 psf) considered
SEISMIC: $k_h = 0.2$
 $k_v = 0.0$
SOIL: $\phi = 34^\circ$
 $\gamma = 120$ pcf
REINFORCED CONCRETE: $f'_c = 3,600$ psi
 $f_y = 60,000$ psi
LOAD COMBINATIONS AND LIMIT STATES:
 Service I $Q = 1.00DC + 1.00EV + 1.00EH + 1.00LS$
 Strength I $Q = aDC + \rho EV + \eta EH + 1.75LS$
 Extreme I $Q = 1.00DC + 1.00EV + 1.00EH + 1.00EQD + 1.00EQE$

Where:

Q: Force Effects
a: 1.25 or 0.90, Whichever Controls Design
 ρ : 1.35 or 1.00, Whichever Controls Design
 η : 1.50 or 0.90, Whichever Controls Design
DC: Dead Load of Structure Components
EH: Horizontal Earth Fill Pressure
EV: Vertical Earth Pressure from Earth Fill Weight
LS: Live Load Surcharge
EQE: Seismic Earth Pressure
EQD: Soil and Structural and Nonstructural Components Inertia

SYMBOLS:

Ser - service limit state I
 Str - strength limit state I
 Ext - extreme event limit state I
 B' - effective footing width (ft)
 q₀ - net bearing stress (ksf), OG assumed to be FG at toe
 q_o - gross uniform bearing stress (ksf)
 h1 = Top of footing to top of short © bar
 h2 = Top of footing to top of © bar
 h3 = Top of footing to top of © bar
 Zone 1 = Top half of stem height
 Zone 2 = Bottom half of stem height
 ∞ - Bundle of two bars

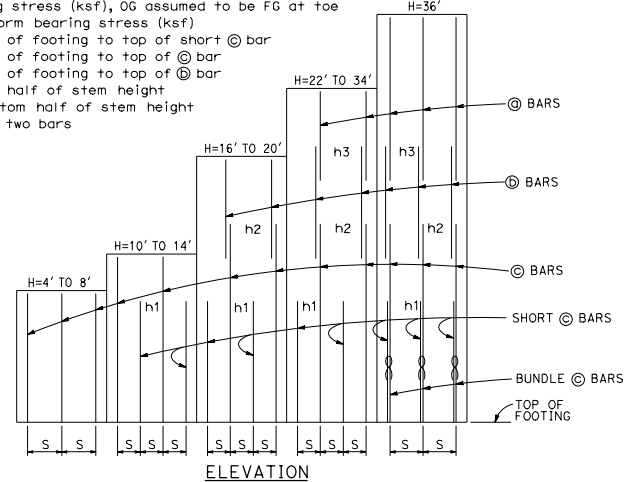

		TABLE OF REINFORCING STEEL, DIMENSIONS AND DATA																
DESIGN H		4'	6'	8'	10'	12'	14'	16'	18'	20'	22'	24'	26'	28'	30'	32'	34'	36'
W		6'-5"	7'-3"	8'-3"	9'-3"	10'-8"	12'-6"	13'-9"	15'-1"	16'-6"	17'-10"	19'-3"	20'-4"	21'-5"	22'-8"	23'-11"	25'-1"	26'-4"
C		2'-2"	2'-6"	3'-0"	3'-6"	3'-8"	3'-11"	4'-0"	4'-7"	5'-3"	6'-0"	7'-0"	7'-9"	8'-3"	8'-8"	9'-0"	9'-6"	9'-10"
B		4'-3"	4'-9"	5'-3"	5'-9"	7'-0"	8'-7"	9'-9"	10'-6"	11'-3"	11'-10"	12'-3"	12'-7"	13'-2"	14'-0"	14'-11"	15'-7"	16'-6"
F		1'-4"	1'-4"	1'-4"	1'-6"	1'-6"	1'-6"	1'-8"	2'-0"	2'-4"	2'-9"	3'-2"	3'-0"	3'-0"	3'-0"	3'-3"	3'-3"	3'-3"
BATTER		1/2: 12	1/2: 12	1/2: 12	1/2: 12	1/2: 12	1/2: 12	1/2: 12	1/2: 12	1/2: 12	1/2: 12	5/8: 12	3/4: 12	1: 12	1: 12	1 1/8: 12	1 1/8: 12	1 1/8: 12
SPACING "S"		16"	16"	16"	8"	8"	7"	7"	7"	6"	6"	7"	7"	7"	6"	6"	6"	8"
© BARS		-	-	-	-	-	-	-	-	#5	#5	#5	#5	#5	#5	#5	#6	#6
Ⓞ BARS		-	-	-	-	-	-	#5	#5	#5	#7	#7	#7	#8	#8	#8	#8	#9
Ⓢ BARS		#5	#5	#6	#5	#6	#6	#7	#8	#8	#9	#10	#10	#10	#10	#10	#11	#11
Ⓣ BARS		#5	#5	#6	#5	#6	#8	#9	#9	#9	#10	#11	#9	#9	#9	#10	#10	#9
h1		-	-	-	4'-2"	4'-7"	6'-2"	7'-3"	8'-6"	8'-8"	9'-8"	11'-0"	12'-2"	14'-0"	13'-0"	15'-10"	14'-6"	12'-0"
h2		-	-	-	-	-	-	10'-6"	12'-9"	14'-2"	13'-8"	17'-0"	18'-6"	17'-10"	18'-9"	20'-3"	21'-0"	17'-0"
h3		-	-	-	-	-	-	-	-	-	15'-6"	17'-9"	19'-6"	21'-8"	23'-0"	24'-8"	25'-6"	24'-8"
No. of Toe Stirrups		0	0	0	0	0	0	0	0	0	0	0	6	6	7	7	7	8
No. of Heel Stirrups		0	0	0	0	0	0	0	0	0	0	6	6	6	6	6	6	6
ZONE 1 © BARS		#5 @ 18	#5 @ 18	#5 @ 18	#5 @ 18	#5 @ 18	#5 @ 18	#5 @ 18	#5 @ 18	#5 @ 18	#5 @ 18	#5 @ 18	#5 @ 18	#5 @ 18	#5 @ 18	#5 @ 18	#5 @ 18	#5 @ 18
ZONE 2 © BARS		#5 @ 18	#5 @ 18	#5 @ 18	#5 @ 18	#5 @ 18	#5 @ 18	#5 @ 18	#5 @ 18	#5 @ 18	#5 @ 18	#5 @ 18	#5 @ 18	#5 @ 18	#5 @ 18	#5 @ 18	#5 @ 18	#5 @ 18
ZONE 1 Ⓢ BARS		#4 @ 18	#4 @ 18	#4 @ 18	#4 @ 18	#4 @ 18	#4 @ 18	#4 @ 18	#4 @ 18	#4 @ 18	#4 @ 18	#4 @ 18	#4 @ 18	#4 @ 18	#4 @ 18	#4 @ 18	#4 @ 18	#4 @ 18
ZONE 2 Ⓢ BARS		#4 @ 18	#4 @ 18	#4 @ 18	#4 @ 18	#4 @ 18	#4 @ 18	#4 @ 18	#4 @ 18	#4 @ 18	#4 @ 18	#4 @ 18	#4 @ 18	#4 @ 18	#4 @ 18	#4 @ 18	#4 @ 18	#4 @ 18
Ser: B', q ₀		4.3, 0.8	4.9, 1.1	5.6, 1.3	7.1, 1.5	8.0, 1.8	9.3, 2.1	10.6, 2.3	11.9, 2.5	13.3, 2.6	14.6, 2.8	15.9, 2.9	17.0, 3.0	18.0, 3.1	19.3, 3.3	20.4, 3.5	21.5, 3.7	22.7, 3.9
Str: B', q _o		2.4, 2.2	2.4, 2.7	2.7, 3.2	3.0, 3.7	4.3, 3.8	5.9, 3.8	7.0, 4.1	7.9, 4.3	9.0, 4.5	9.9, 4.7	10.8, 4.9	11.6, 5.0	12.3, 5.2	13.3, 5.4	14.2, 5.7	15.0, 5.9	16.0, 6.1
Ext: B', q _o		4.1, 1.5	3.9, 2.1	3.8, 2.8	3.5, 3.9	3.6, 4.9	4.2, 5.5	4.6, 6.3	5.0, 7.0	5.6, 7.4	6.0, 8.0	6.5, 8.4	6.9, 8.6	7.2, 9.2	7.7, 9.6	8.1, 10.4	8.4, 10.9	8.9, 11.3

STATE OF CALIFORNIA
DEPARTMENT OF TRANSPORTATION
RETAINING WALL TYPE 1 (CASE 3)
RSP B3-1C DATED JULY 21, 2017 SUPERSEDES STANDARD PLAN B3-1C
DATED OCTOBER 30, 2015 - PAGE 288 OF THE STANDARD PLANS BOOK DATED 2015.

NO SCALE

REVISED STANDARD PLAN RSP B3-1C

2015 REVISED STANDARD PLAN RSP B3-1C

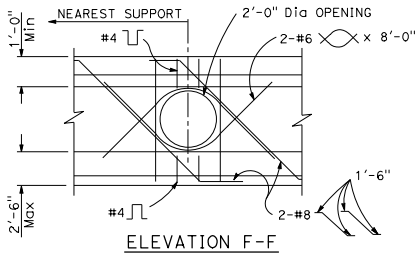

ELEVATION F-F

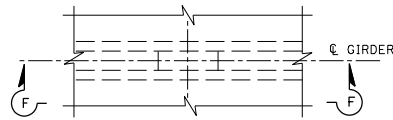

PART PLAN
GIRDER STEM ACCESS OPENING
DETAIL U41

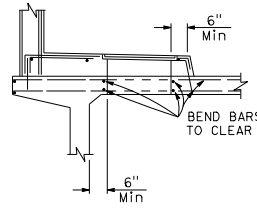

SECTION C-C

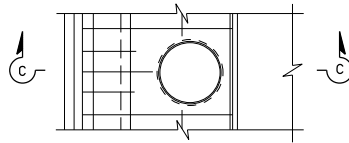

PART PLAN
SIDEWALK ACCESS OPENING
DETAIL U42

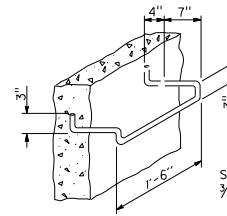

BAR STEP
LADDER RUNG DETAILS
DETAIL U44

Space ladder rung @ 12
3/4" Ø Galvanize after fabrication

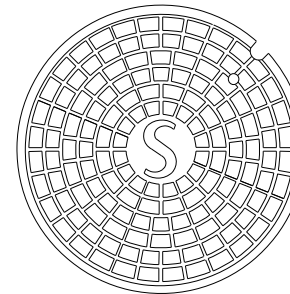

TOP OF MANHOLE COVER

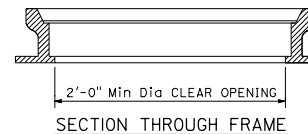

SECTION THROUGH FRAME
NON-ROCKING MANHOLE FRAME & COVER
FOR DECKS
DETAIL U45

NOTES:

- Step inserts may be substituted for the standard step detail. Step inserts shall comply with State Industrial Safety requirements.
- Covers for use on sewer structures shall bear the letter "S"; on storm drain structures the letter "D"; on openings for utilities the letter "U".

Dist	COUNTY	ROUTE	POST MILES TOTAL PROJECT	SHEET TOTAL NO. SHEETS

Peter W. Norboe
REGISTERED CIVIL ENGINEER

July 15, 2016
PLANS APPROVAL DATE

Peter W. Norboe
No. C57519
Exp. 12-31-17
CIVIL
STATE OF CALIFORNIA

THE STATE OF CALIFORNIA OR ITS OFFICERS OR AGENTS SHALL NOT BE RESPONSIBLE FOR THE ACCURACY OR COMPLETENESS OF SCANNED COPIES OF THIS PLAN SHEET.

TO ACCOMPANY PLANS DATED _____

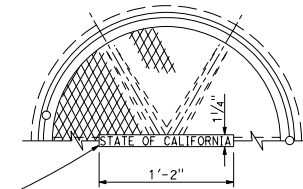

LETTERS 1" HIGH, NO OTHER INSCRIPTION
TO APPEAR ON EXPOSED SURFACES.

TOP OF MANHOLE FRAME & COVER

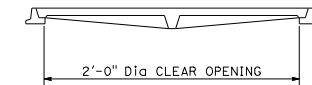

SECTION THROUGH FRAME & COVER
MANHOLE FRAME & COVER
FOR SIDEWALKS
DETAIL U46

NOTES:

- Frame and cover shall be cast iron.
- Cover shall be supplied with bolt down or locking devices.

STATE OF CALIFORNIA
DEPARTMENT OF TRANSPORTATION
UTILITY DETAILS

NO SCALE

RSP B7-11 DATED JULY 15, 2016 SUPERSEDES STANDARD PLAN B7-11
DATED OCTOBER 30, 2015 - PAGE 308 OF THE STANDARD PLANS BOOK DATED 2015.

REVISED STANDARD PLAN RSP B7-11

NOTES:

- For exact location of openings see other sheets.
- Location and size of manholes may be modified as directed by the Engineer, provided minimum dimensions are maintained.
- All reinforcement detailed to be placed in addition to reinforcement shown on other sheets.

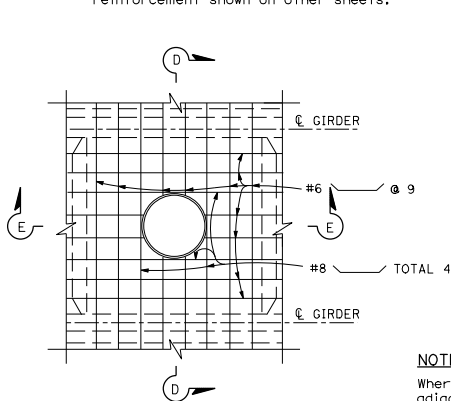

PART PLAN

DECK ACCESS OPENING
DETAIL U43

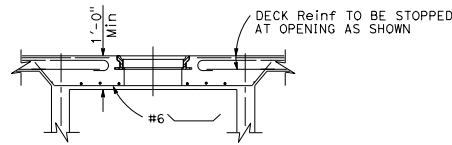

SECTION D-D

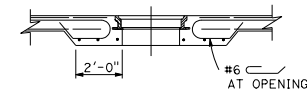

SECTION E-E

NOTE:

Where manhole is located adjacent to a diaphragm or abut, substitute half Section E-E on one side of Section E-E.

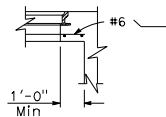

HALF SECTION E-E

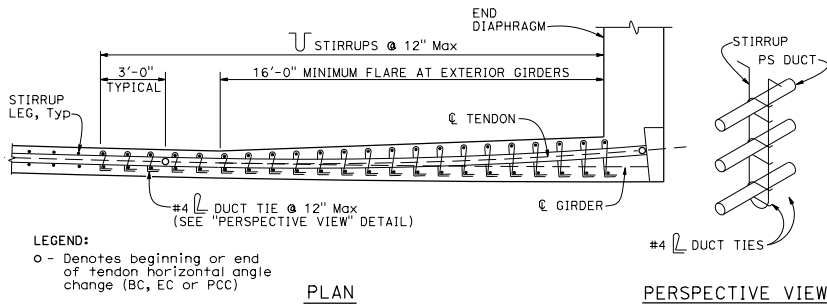

**DUCT TIES AT TENDON HORIZONTAL ANGLE CHANGES
DETAIL 5-1**

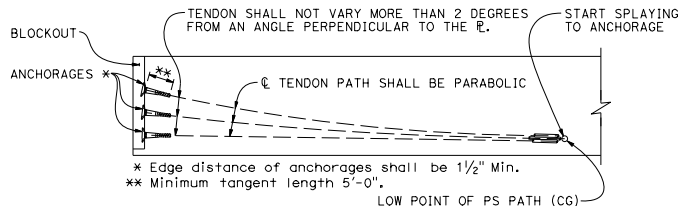

**ELEVATION - ANCHORAGES AND PRESTRESSING PATH
DETAIL 5-2**

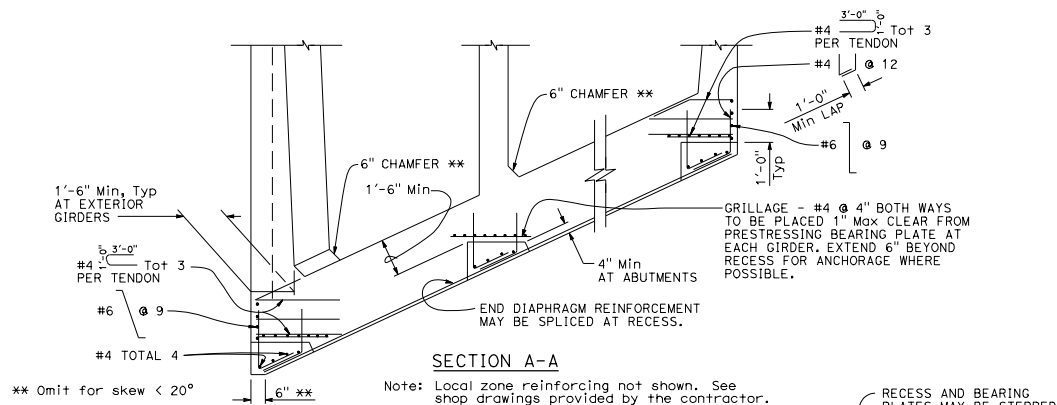

**PRESTRESS ANCHORAGE DETAILS
AT END DIAPHRAGMS
DETAIL 5-3**

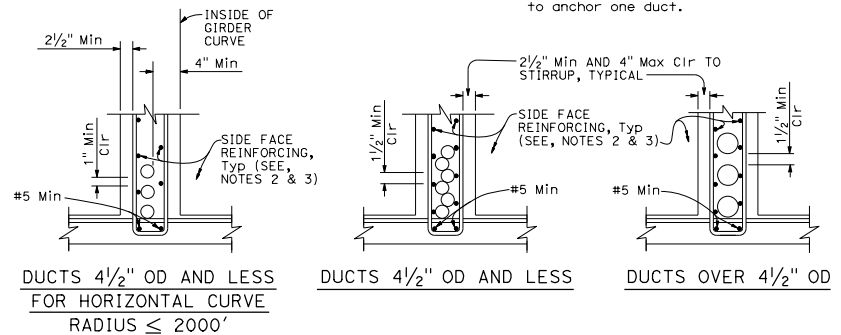

**CLEARANCE REQUIREMENTS FOR DUCTS
DETAIL 5-4**

- NOTES FOR DETAIL 5-4:**
- Stirrups may also be used.
 - For additional details, see Standard Plan B7-1, and Project Plans.
 - Bar reinforcing which interferes with prestressing ducts may be adjusted as approved by the Engineer.
 - The detail for "DUCTS OVER 4 1/2" OD" shall be used on tangent and horizontally curved alignments.

STATE OF CALIFORNIA
DEPARTMENT OF TRANSPORTATION

**CAST-IN-PLACE
POST-TENSIONED GIRDER DETAILS**

NO SCALE

RSP B8-5 DATED JANUARY 20, 2017 SUPERSEDES STANDARD PLAN B8-5
DATED OCTOBER 30, 2015 - PAGE 309 OF THE STANDARD PLANS BOOK DATED 2015.
REVISED STANDARD PLAN RSP B8-5

DIST	COUNTY	ROUTE	POST MILES TOTAL PROJECT	SHEET NO.	TOTAL SHEETS
REGISTERED CIVIL ENGINEER January 20, 2017 PLANS APPROVAL DATE THE STATE OF CALIFORNIA OR ITS OFFICERS OR AGENTS SHALL NOT BE RESPONSIBLE FOR THE ACCURACY OR COMPLETENESS OF SCANNED COPIES OF THIS PLAN SHEET.					

TO ACCOMPANY PLANS DATED _____

NOTES FOR DETAIL 5-1

- Tendon horizontal angle change at end diaphragm shown. Duct tie placement similar for other locations where tendon horizontal angle changes occur. For curved girders place duct ties at tendon angle changes where tendon radius is smaller than tendon radius.
- Adjacent duct ties may be staggered vertically to facilitate placement if stirrup spacing is 6 inches or less.
- Place closed end of duct ties toward inside of tendon curve.
- Wrap duct ties around both stirrup legs.
- Individual duct ties may only be used to anchor one duct.

2015 REVISED STANDARD PLAN RSP B8-5

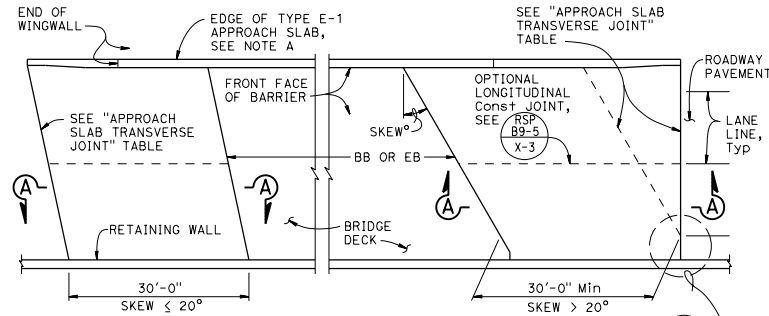

NOTE A:
Type E-1 Approach Slab shown, see RSP B9-5 X-2 for Type E-2 details.

PLAN

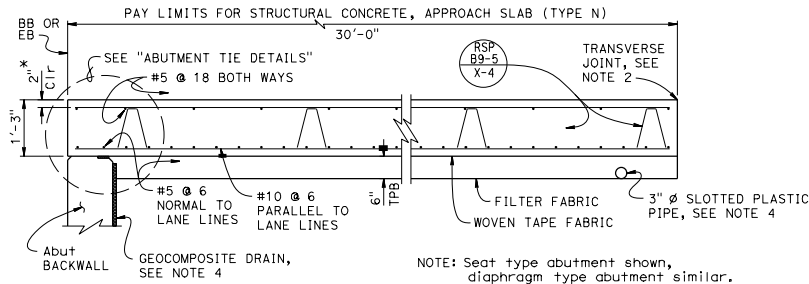

NOTE: Seat type abutment shown, diaphragm type abutment similar.

SECTION A-A

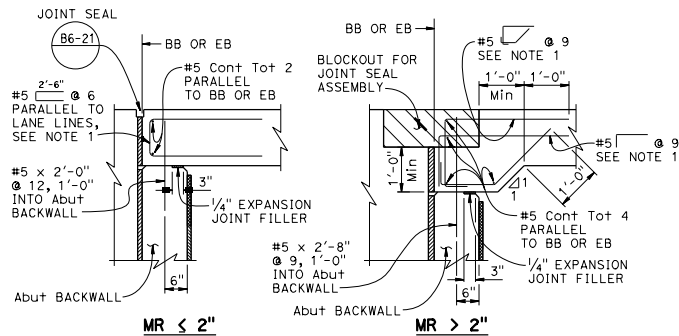

SEAT TYPE ABUTMENT

ABUTMENT TIE DETAILS

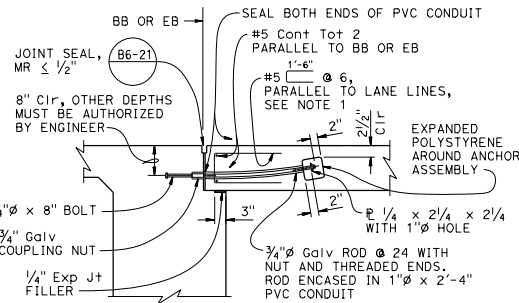

DIAPHRAGM TYPE ABUTMENT

APPROACH SLAB TRANSVERSE JOINT		
APPROACH SKEW, x	WITH HMA ROADWAY PAVEMENT	WITH PCC ROADWAY PAVEMENT
$x < 20^\circ$	PARALLEL TO BB OR EB	PARALLEL TO BB OR EB
$20^\circ < x < 45^\circ$	PARALLEL TO BB OR EB	STAGGER AT LANE LINES 24' TO 36' APART, SEE "END STAGGER DETAIL"
$x > 45^\circ$	PARALLEL TO BB OR EB	STAGGER AT EACH LANE LINE, SEE "END STAGGER DETAIL"

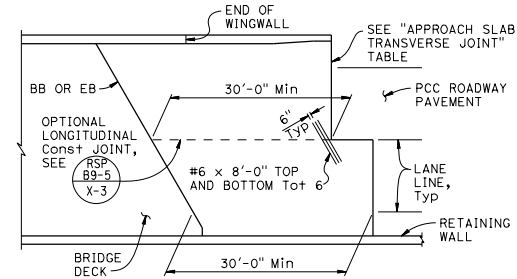

END STAGGER DETAIL

LEGEND:

* - All approach slab reinforcement shall be epoxy coated and minimum top mat cover 2 1/2" in Freeze-Thaw Area.

NOTES:

1. For $MR \leq 2''$, adjust reinforcement to clear sawcut for sealed joint. For $MR > 2''$, reinforcement must be normal to BB or EB and spaced to avoid joint seal assembly anchorage.
2. Transverse Joint must be a minimum of 5'-0" from an existing or constructed weakened plane joint in approach PCC roadway pavement. Refer to Standard Plans P10 and P14.
3. At the Contractor's option, approach slab transverse reinforcement may be placed parallel to BB or EB. Spacing of transverse reinforcement is measured along ℓ roadway.
4. For structure approach drainage details, refer to Revised Standard Plan RSP B9-6.
5. For details not shown, refer to Revised Standard Plan RSP B9-5.

STATE OF CALIFORNIA
DEPARTMENT OF TRANSPORTATION

**STRUCTURE APPROACH
TYPE N (30)**

NO SCALE

RSP B9-1 DATED JULY 21, 2017 SUPPLEMENTS THE STANDARD PLANS BOOK DATED 2015.

REVISED STANDARD PLAN RSP B9-1

DIST	COUNTY	ROUTE	POST MILES TOTAL PROJECT	SHEET TOTAL SHEETS

REGISTERED CIVIL ENGINEER
E.J. Sims
No. C46471
Exp. 6-30-19
REGISTERED PROFESSIONAL ENGINEER
No. 63019
CIVIL
STATE OF CALIFORNIA

PLANS APPROVAL DATE
July 21, 2017

TO ACCOMPANY PLANS DATED _____

2015 REVISED STANDARD PLAN RSP B9-1

Dist	COUNTY	ROUTE	POST MILES	SHEET TOTAL
			TOTAL PROJECT	No. SHEETS

July 21, 2017
 PLANS APPROVAL DATE
 THE STATE OF CALIFORNIA OR ITS OFFICERS OR AGENTS SHALL NOT BE RESPONSIBLE FOR THE ACCURACY OR COMPLETENESS OF SCANNED COPIES OF THIS PLAN SHEET.

TO ACCOMPANY PLANS DATED _____

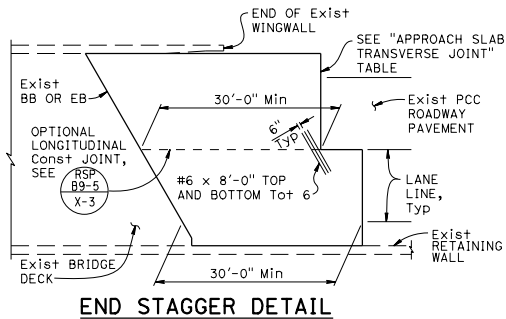
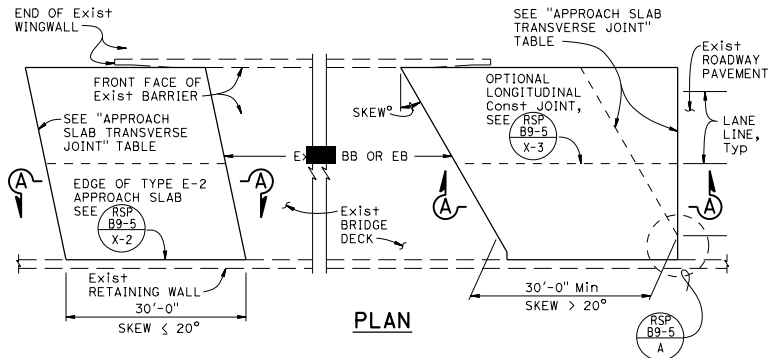

APPROACH SLAB TRANSVERSE JOINT		
APPROACH SKEW, X	WITH HMA ROADWAY PAVEMENT	WITH PCC ROADWAY PAVEMENT
X < 20°	PARALLEL TO BB OR EB	PARALLEL TO BB OR EB
20° < X < 45°	PARALLEL TO BB OR EB	STAGGER AT LANE LINES 24' TO 36' APART, SEE "END STAGGER DETAIL"
X > 45°	PARALLEL TO BB OR EB	STAGGER AT EACH LANE LINE, SEE "END STAGGER DETAIL"

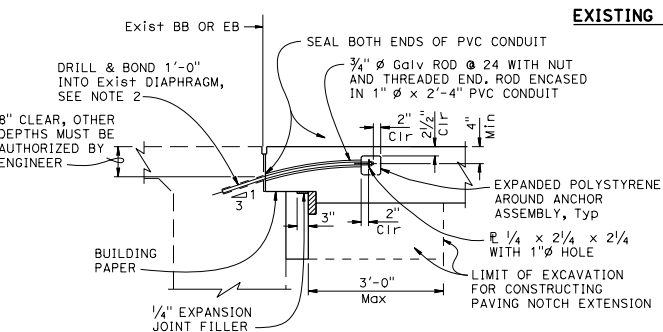
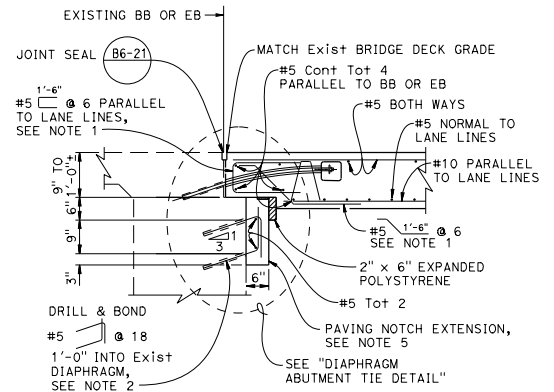
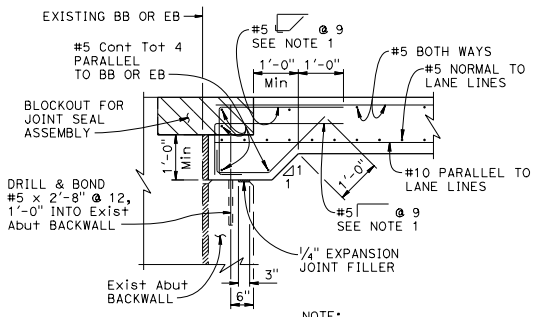
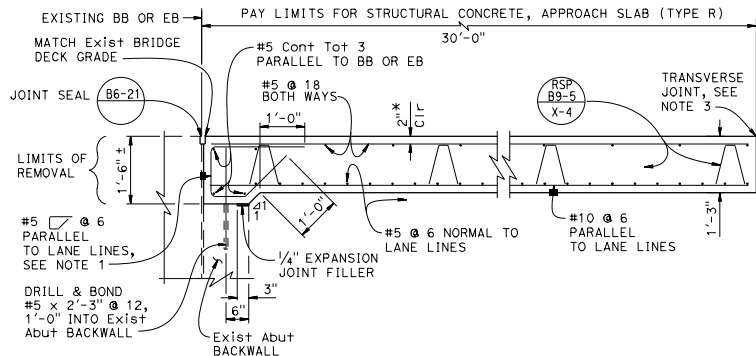

SECTION A-A

NOTES:

- For MR < 2', adjust reinforcement to clear sawcut for sealed joint. For MR > 2', reinforcement must be normal to BB or EB and spaced to avoid joint seal assembly.
- Space reinforcement and abutment ties to avoid existing prestressing anchorages and other reinforcement in abutment, as needed.
- Transverse Joint must be a minimum of 5'-0" from an existing or constructed weakened plane joint in approach PCC roadway pavement. Refer to Standard Plans P10 and P14.
- At the Contractor's option, approach slab transverse reinforcement may be placed parallel to BB or EB. Spacing of transverse reinforcement is measured along E roadway.
- Paving notch extension is required if existing diaphragm paving notch is < 6".
- For details not shown, refer to Revised Standard Plan RSP B9-5.

LEGEND:

- - - Indicates Existing Structure
- * - All approach slab reinforcement shall be epoxy coated and top mat cover 2 1/2" clear in Freeze-Thaw Area.

STATE OF CALIFORNIA
 DEPARTMENT OF TRANSPORTATION
**STRUCTURE APPROACH
 TYPE R (30)**
 NO SCALE

RSP B9-2 DATED JULY 21, 2017 SUPPLEMENTS THE STANDARD PLANS BOOK DATED 2015.

REVISED STANDARD PLAN RSP B9-2

2015 REVISED STANDARD PLAN RSP B9-2

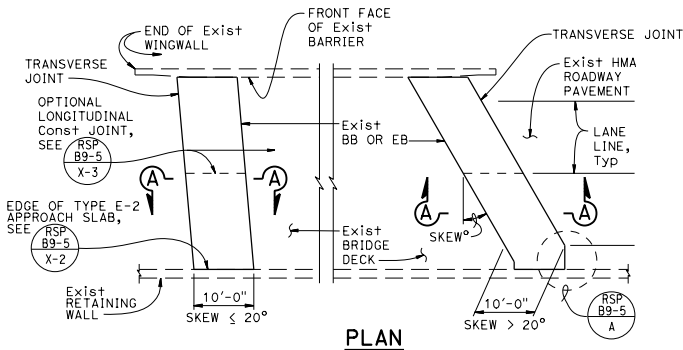

PLAN

LEGEND:

-- Indicates Existing Structure

* - All approach slab reinforcement shall be epoxy coated and top mat cover 2 1/2" clear in Freeze-Thaw Area.

NOTES:

1. For MR ≤ 2', adjust reinforcement to clear sawcut for sealed joint. For MR > 2', reinforcement must be normal to BB or EB and spaced to avoid joint seal assembly anchorage.
2. Space reinforcement and abutment ties to avoid existing prestressing anchorages and other reinforcement in abutment, as needed.
3. At the Contractor's option, approach slab transverse reinforcement may be placed parallel to BB or EB. Spacing of transverse reinforcement is measured along C roadway.
4. Paving notch extension is required if existing diaphragm paving notch is < 6".
5. For details not shown, refer to Revised Standard Plan RSP B9-5.

DIST	COUNTY	ROUTE	POST MILES TOTAL PROJECT	SHEET TOTAL SHEETS

[Signature]
 REGISTERED CIVIL ENGINEER
 No. C46471
 July 21, 2017
 PLANS APPROVAL DATE
 THE STATE OF CALIFORNIA OR ITS OFFICERS OR AGENTS SHALL NOT BE RESPONSIBLE FOR THE ACCURACY OR COMPLETENESS OF SCANNED COPIES OF THIS PLAN SHEET.
 REGISTERED PROFESSIONAL ENGINEER
 E.J. SIMS
 No. 6-30-19
 CIVIL
 STATE OF CALIFORNIA

TO ACCOMPANY PLANS DATED _____

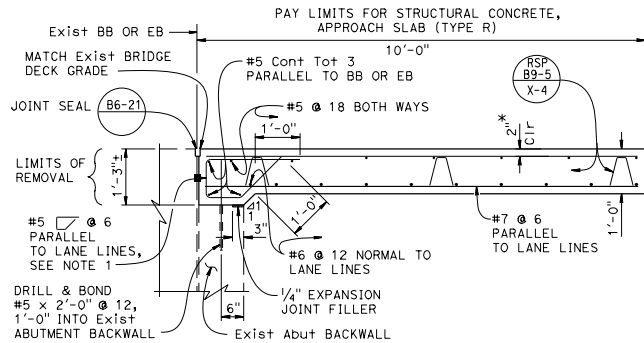

SEATED JOINT

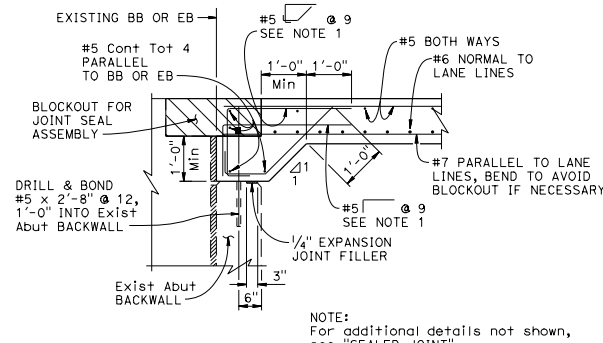

JOINT SEAL ASSEMBLY

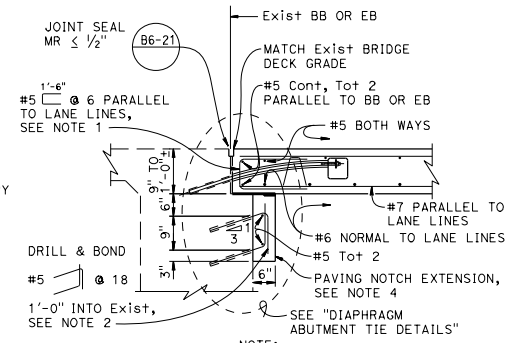

EXISTING DIAPHRAGM ABUTMENT

EXISTING SEAT ABUTMENT

SECTION A-A

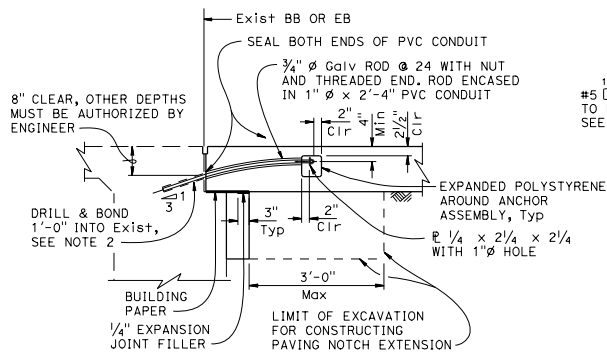

12" PAVING NOTCH

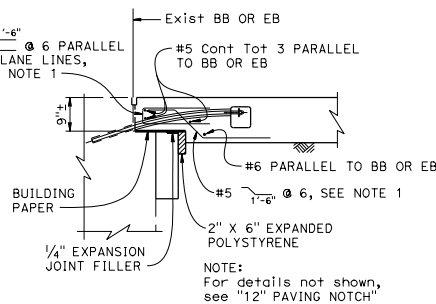

9" PAVING NOTCH

DIAPHRAGM ABUTMENT TIE DETAILS

STATE OF CALIFORNIA
DEPARTMENT OF TRANSPORTATION
**STRUCTURE APPROACH
TYPE R (10)**
NO SCALE

RSP B9-3 DATED JULY 21, 2017 SUPPLEMENTS THE STANDARD PLANS BOOK DATED 2015.

REVISED STANDARD PLAN RSP B9-3

2015 REVISED STANDARD PLAN RSP B9-3

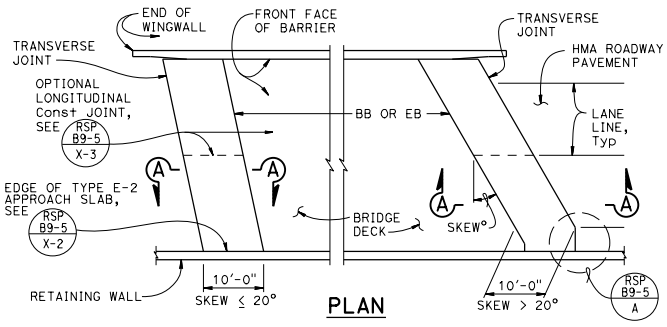

PLAN

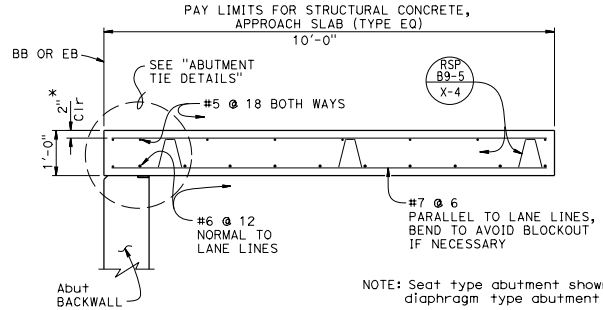

SECTION A-A

NOTE: Seat type abutment shown, diaphragm type abutment similar.

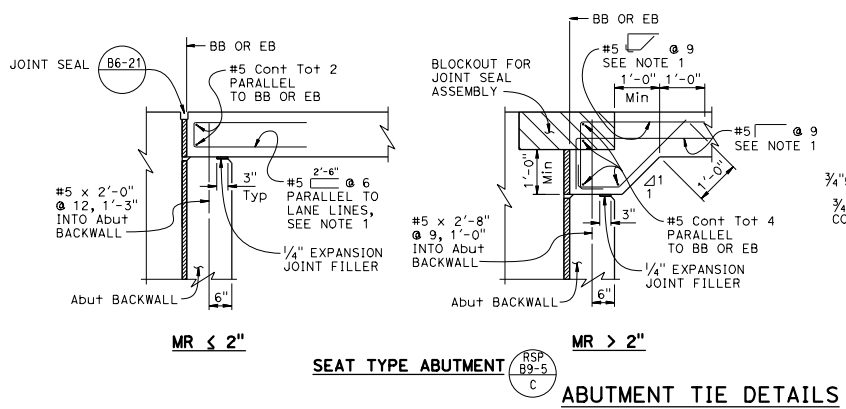

ABUTMENT TIE DETAILS

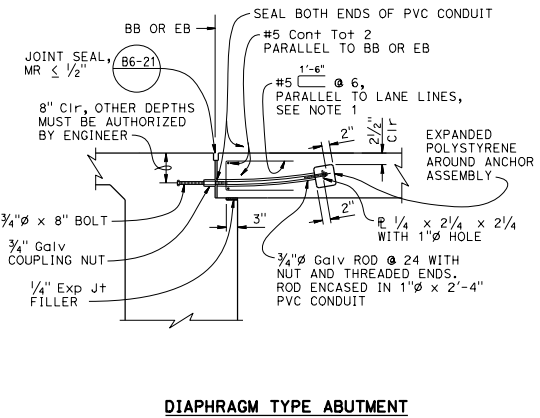

DIAPHRAGM TYPE ABUTMENT

LEGEND:

* - All approach slab reinforcement shall be epoxy coated and minimum top mat cover 2 1/2" in Freeze-Thaw Area.

NOTES:

1. For $MR \leq 2''$, adjust reinforcement to clear sawcut for sealed joint. For $MR > 2''$, reinforcement must be normal to BB or EB and spaced to avoid joint seal assembly anchorage.
2. At the Contractor's option, approach slab transverse reinforcement may be placed parallel to BB or EB. Spacing of transverse reinforcement is measured along roadway.
3. For details not shown, refer to Revised Standard Plan RSP B9-5.

DIST	COUNTY	ROUTE	POST MILES TOTAL PROJECT	SHEET TOTAL SHEETS

REGISTERED CIVIL ENGINEER
 July 21, 2017
 PLANS APPROVAL DATE
 THE STATE OF CALIFORNIA OR ITS OFFICERS OR AGENTS SHALL NOT BE RESPONSIBLE FOR THE ACCURACY OR COMPLETENESS OF SCANNED COPIES OF THIS PLAN SHEET.

TO ACCOMPANY PLANS DATED _____

STATE OF CALIFORNIA
DEPARTMENT OF TRANSPORTATION
**STRUCTURE APPROACH
TYPE EQ (10)**
NO SCALE

RSP B9-4 DATED JULY 21, 2017 SUPPLEMENTS THE STANDARD PLANS BOOK DATED 2015.
REVISED STANDARD PLAN RSP B9-4

2015 REVISED STANDARD PLAN RSP B9-4

DIST	COUNTY	ROUTE	POST MILES TOTAL PROJECT	SHEET TOTAL SHEETS

	
REGISTERED CIVIL ENGINEER July 21, 2017 PLANS APPROVAL DATE THE STATE OF CALIFORNIA OR ITS OFFICERS OR AGENTS SHALL NOT BE RESPONSIBLE FOR THE ACCURACY OR COMPLETENESS OF SCANNED COPIES OF THIS PLAN SHEET.	

TO ACCOMPANY PLANS DATED _____

DESIGN NOTES

DESIGN: AASHTO LRFD Bridge Design Specifications, 2012 Edition with Caltrans Amendments, preface dated January 2014.

LIMIT STATES: Service I, Strength I & II, Extreme II and Fatigue I ($\gamma_{FAT} = 1.0$)

DEAD LOAD: Includes 35 psf for future wearing surface

LIVE LOAD: HL93 and permit design load
Equivalent strip width method: $W_e = 12$ ft
Slab span: $L_1 = 24.5$ ft (30 ft Approach Slab)
Slab span: $L_2 = 7.83$ ft (10 ft Approach Slab)

REINFORCED CONCRETE:
 $f_y = 60$ ksi
 $f'_c = 3.6$ ksi
 $n = 8$

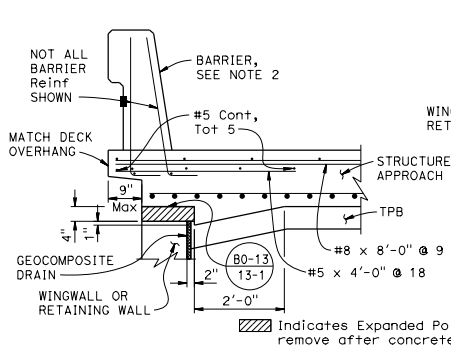

DETAIL X-1
TYPE E-1

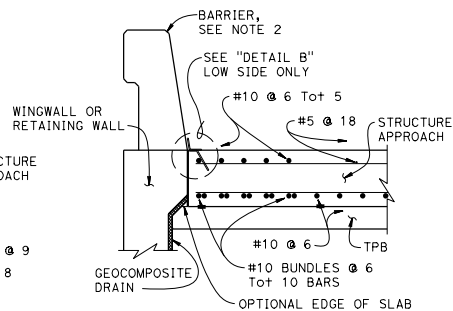

DETAIL X-2
TYPE E-2

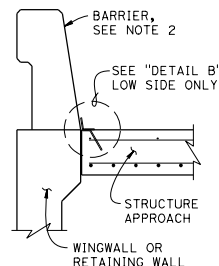

DETAIL X-2
TYPE R (10) & EQ

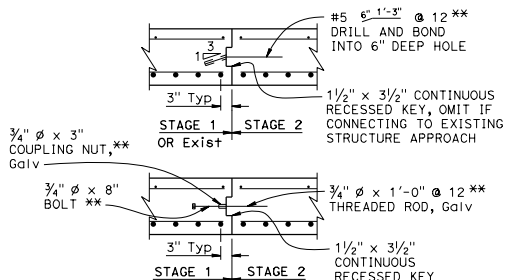

DETAIL X-3
LONGITUDINAL CONSTRUCTION JOINT ALTERNATIVES

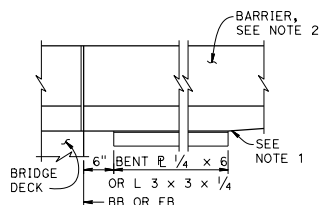

EDGE ANGLE PLAN

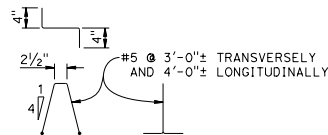

DETAIL X-4
BAR CHAIR DETAIL

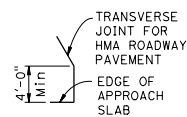

DETAIL A

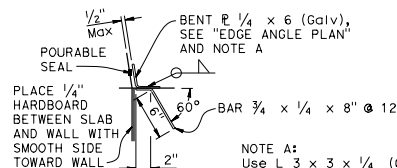

DETAIL B

NOTE A:
Use L 3 x 3 x 1/4 (galv) for concrete barrier or curb with vertical face.

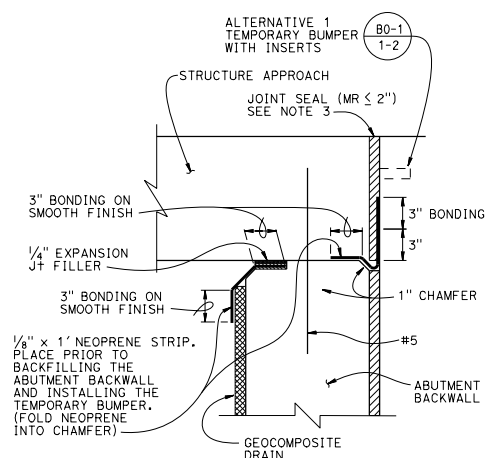

DETAIL C

STATE OF CALIFORNIA DEPARTMENT OF TRANSPORTATION **STRUCTURE APPROACH SLAB DETAILS**

NO SCALE

RSP B9-5 DATED JULY 21, 2017 SUPPLEMENTS THE STANDARD PLANS BOOK DATED 2015.
REVISED STANDARD PLAN RSP B9-5

LEGEND:

- * Min lap splice for bottom Reinf in Freeze-Thaw Area shall be 3'-6".
- ** Threaded Rods and Dowels in Freeze-Thaw Area shall be stainless steel.

NOTES:

1. End the plate or edge angle at beginning of barrier transition, end of wingwall or end of structure approach as applicable.
2. Solid concrete barrier shown, details similar for all concrete and standard post-beam barriers.
3. Joint protection details shown for $MR \leq 2'$. Details similar when joint seal assembly is required.

2015 REVISED STANDARD PLAN RSP B9-5

DIST	COUNTY	ROUTE	POST MILES TOTAL PROJECT	SHEET TOTAL SHEETS

[Signature]
 REGISTERED CIVIL ENGINEER
 No. C46471
 July 21, 2017
 PLANS APPROVAL DATE
 REGISTERED PROFESSIONAL ENGINEER
 E.J. Sims
 No. 63019
 CIVIL
 STATE OF CALIFORNIA

THE STATE OF CALIFORNIA OR ITS OFFICERS OR AGENTS SHALL NOT BE RESPONSIBLE FOR THE ACCURACY OR COMPLETENESS OF SCANNED COPIES OF THIS PLAN SHEET.

TO ACCOMPANY PLANS DATED _____

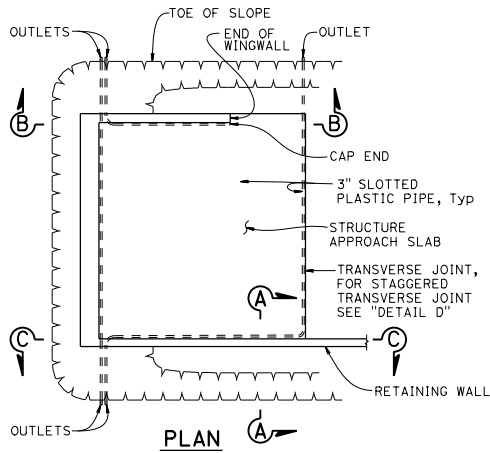

PLAN

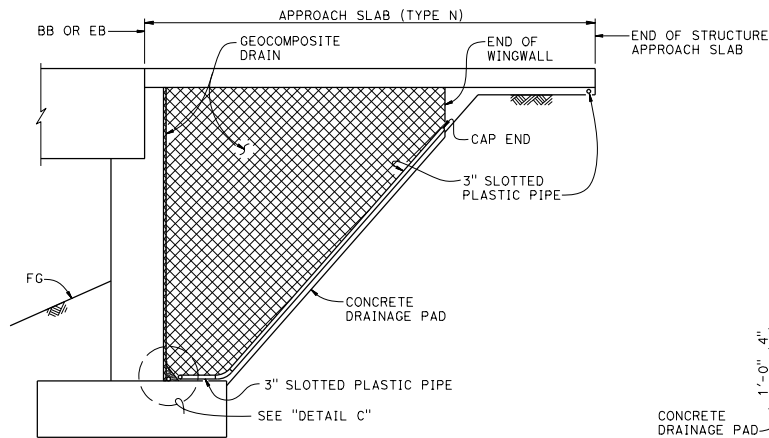

SECTION B-B

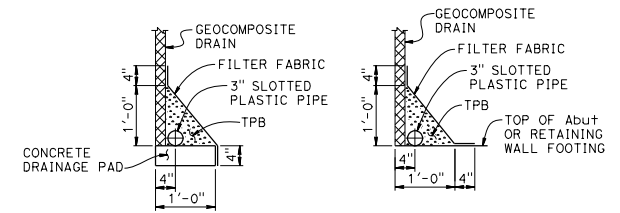

DRAINAGE PAD

FOOTING

DETAIL C

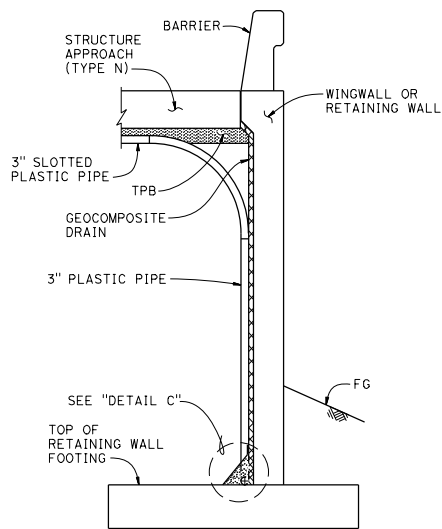

SECTION A-A

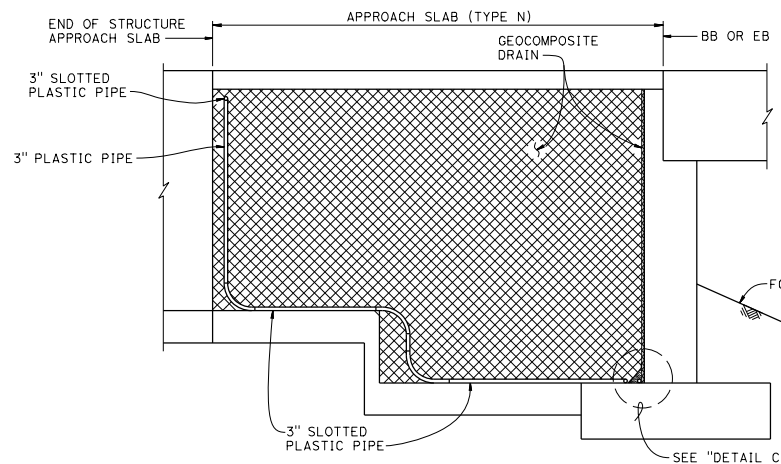

SECTION C-C

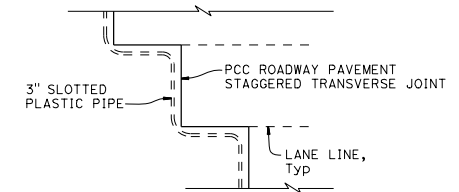

DETAIL D

NOTES:

1. All bends in plastic pipe must have 3'-0" minimum radius. Plastic pipe used for bends is not required to be slotted.
2. For Approach Slab (Type N) details, refer to Revised Standard Plan RSP B9-1.

STATE OF CALIFORNIA
DEPARTMENT OF TRANSPORTATION
**STRUCTURE APPROACH
DRAINAGE DETAILS**
NO SCALE

RSP B9-6 DATED JULY 21, 2017 SUPPLEMENTS THE STANDARD PLANS BOOK DATED 2015.

REVISED STANDARD PLAN RSP B9-6

2015 REVISED STANDARD PLAN RSP B9-6

DIST	COUNTY	ROUTE	POST MILES TOTAL PROJECT	SHEET TOTAL SHEETS

REGISTERED CIVIL ENGINEER
Tillot Satter
No. C42892
PLANS APPROVAL DATE
January 20, 2017
EXP. 3-31-18
CIVIL
STATE OF CALIFORNIA

THE STATE OF CALIFORNIA OR ITS OFFICERS OR AGENTS SHALL NOT BE RESPONSIBLE FOR THE ACCURACY OR COMPLETENESS OF SCANNED COPIES OF THIS PLAN SHEET.

TO ACCOMPANY PLANS DATED _____

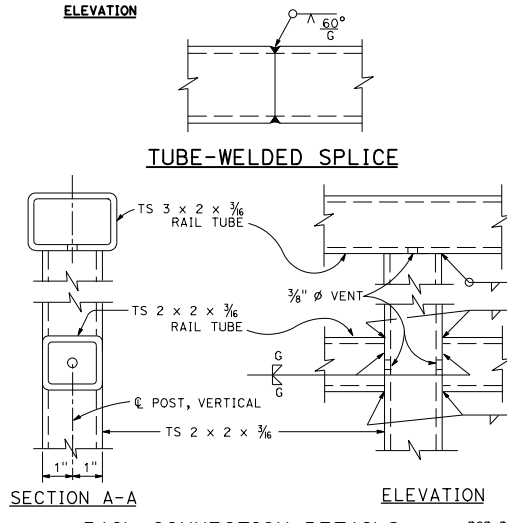
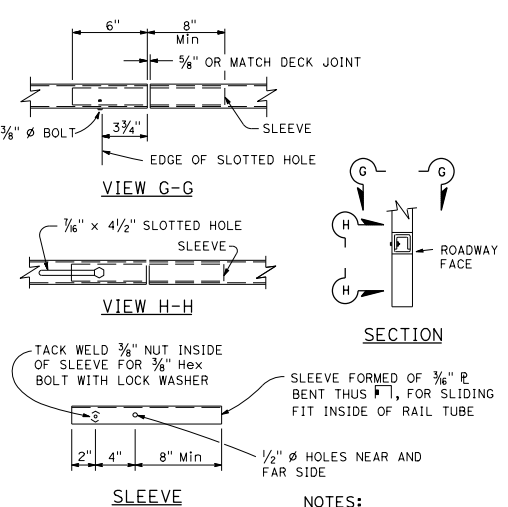
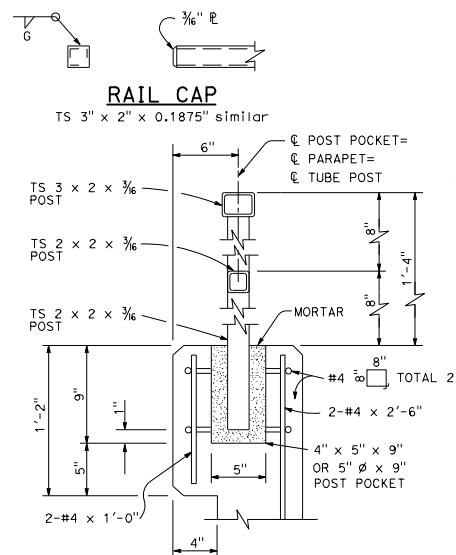
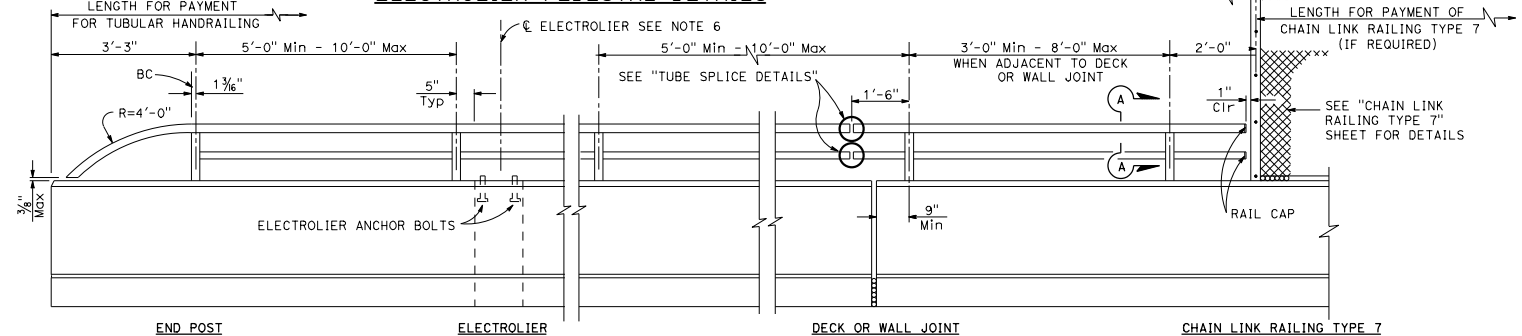
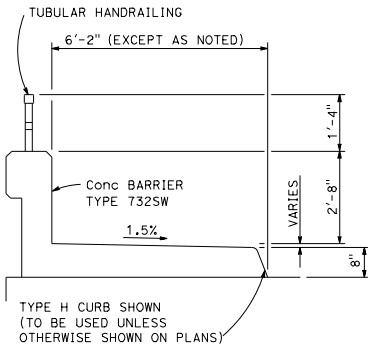
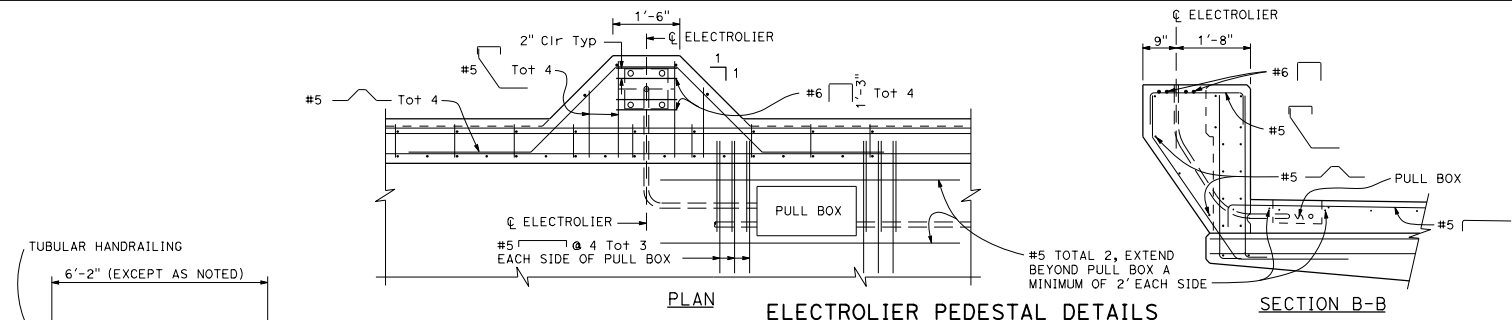

- NOTES:**
1. Post shall be normal to railing.
 2. Rail tubes shall be shop bent or fabricated to fit horizontal curve when radius is less than 950'.
 3. Tube splices shall be located in the tubes spanning deck or wall joints. Increase joint width in tubes to match expansion joint width and increase sleeve length correspondingly.
 4. Top rail tube shall be continuous over not less than two posts except a short post spacing is permitted near deck or wall joints, electroliers, or other rail discontinuities as noted.
 5. For details and reinforcement not shown see Revised Standard Plans RSP B11-54.
 6. For electrolier mounting details, see Revised Standard Plans RSP ES-6A and RSP ES-6B.

STATE OF CALIFORNIA
DEPARTMENT OF TRANSPORTATION
TUBULAR HANDRAILING
NO SCALE

RSP B11-51 DATED JANUARY 20, 2017 SUPERSEDES RSP B11-51 DATED JULY 15, 2016 AND STANDARD PLAN B11-51 DATED OCTOBER 30, 2015 - PAGE 312 OF THE STANDARD PLANS BOOK DATED 2015.

REVISED STANDARD PLAN RSP B11-51

2015 REVISED STANDARD PLAN RSP B11-51

DIST	COUNTY	ROUTE	POST MILES TOTAL PROJECT	SHEET TOTAL SHEETS

REGISTERED CIVIL ENGINEER	
January 20, 2017	
PLANS APPROVAL DATE	

THE STATE OF CALIFORNIA OR ITS OFFICERS OR AGENTS SHALL NOT BE RESPONSIBLE FOR THE ACCURACY OR COMPLETENESS OF SCANNED COPIES OF THIS PLAN SHEET.

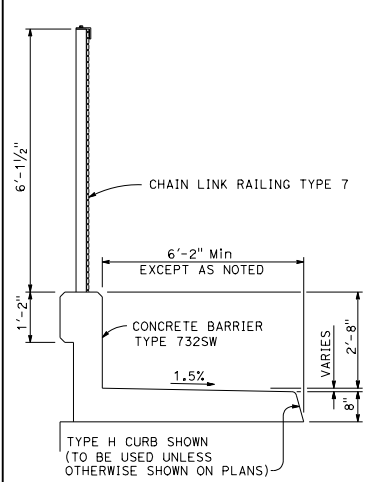

TYPICAL SECTION

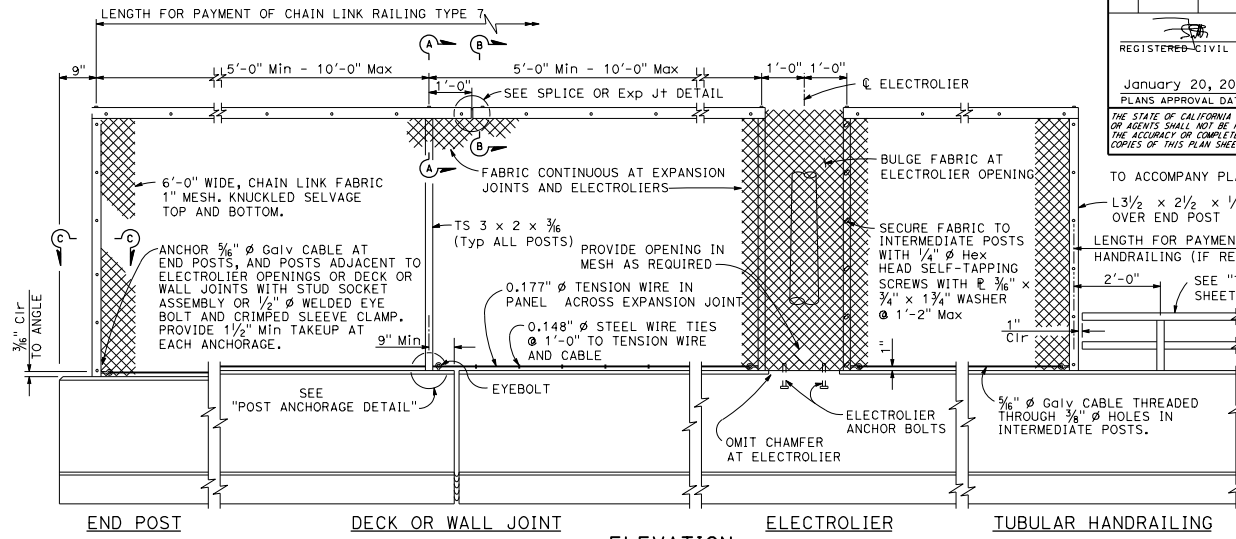

ELEVATION

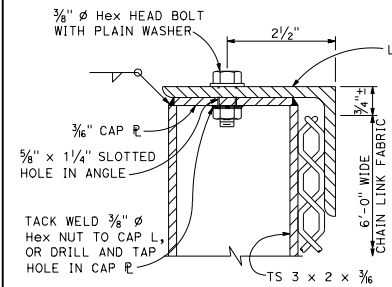

SECTION A-A

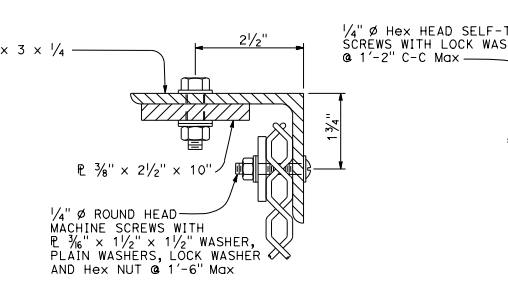

SECTION B-B

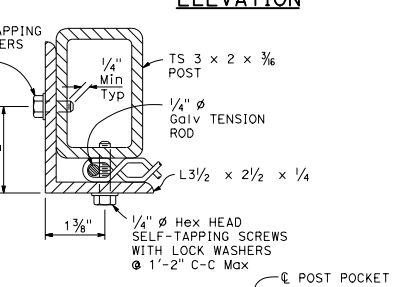

SECTION C-C

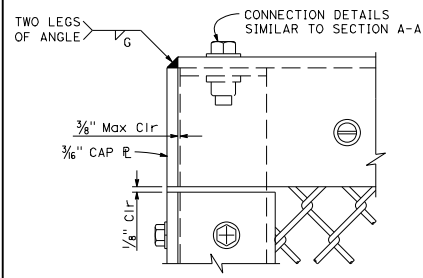

END POST ELEVATION

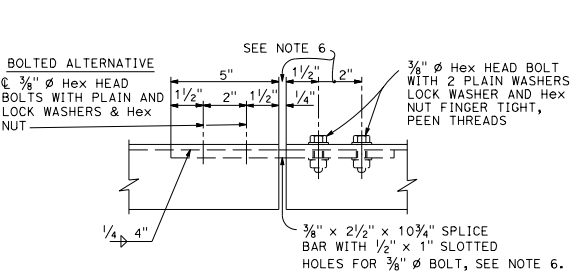

SPLICE OR EXPANSION JOINT DETAIL

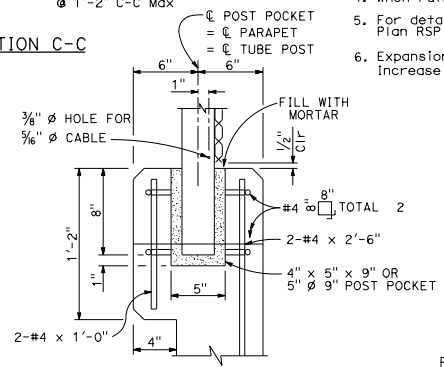

POST ANCHORAGE DETAIL

NOTES:

1. Posts shall be vertical.
2. Railing shall conform to horizontal and vertical alignment. When railing is placed on a curved horizontal alignment with radius of 148'-0" or less, thread the 3/8" diameter cable through 3/8" diameter welded eye rods embedded 4" into the top of the concrete parapet and equally spaced to limit the midordinate distance between the 3/8" diameter cable and the curve to 1" maximum. Horizontal angle shall be bent to conform to horizontal alignment if radius is 148'-0" or less and may be on 10'-0" chords if radius is over 148'-0".
3. Horizontal angle shall be continuous over not less than two intermediate posts, except that a shorter length is permitted at expansion joints, electroliers and other rail discontinuities.
4. When rail is on slope, place fabric parallel to slope.
5. For details and reinforcement not shown see Revised Standard Plan RSP B11-54.
6. Expansion joint same dimension as expansion joint in deck or wall. Increase slotted hole length and splice bar length correspondingly.

STATE OF CALIFORNIA
DEPARTMENT OF TRANSPORTATION
**CHAIN LINK RAILING
TYPE 7**
NO SCALE

RSP B11-52 DATED JANUARY 20, 2017 SUPERSEDES RSP B11-52
DATED OCTOBER 30, 2015 - PAGE 313 OF THE STANDARD PLANS BOOK DATED 2015.
REVISED STANDARD PLAN RSP B11-52

2015 REVISED STANDARD PLAN RSP B11-52

DIST	COUNTY	ROUTE	POST MILES TOTAL PROJECT	SHEET TOTAL SHEETS

REGISTERED CIVIL ENGINEER
Tillot Satter
No. C42892
Exp. 3-31-18
CIVIL
STATE OF CALIFORNIA

July 15, 2016
PLANS APPROVAL DATE

TO ACCOMPANY PLANS DATED _____

THE STATE OF CALIFORNIA OR ITS OFFICERS OR AGENTS SHALL NOT BE RESPONSIBLE FOR THE ACCURACY OR COMPLETENESS OF SCANNED COPIES OF THIS PLAN SHEET.

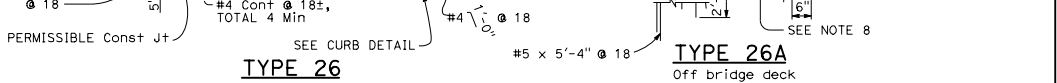
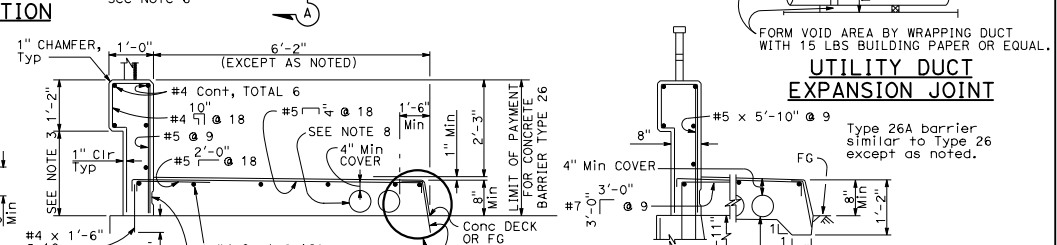
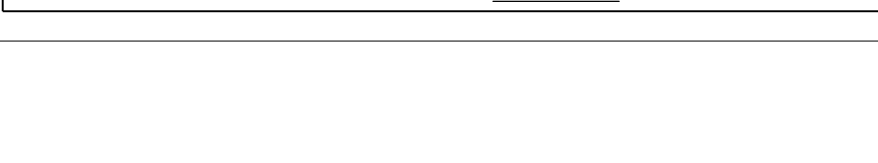
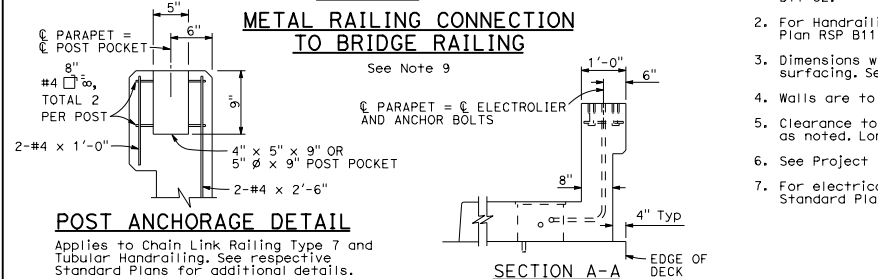
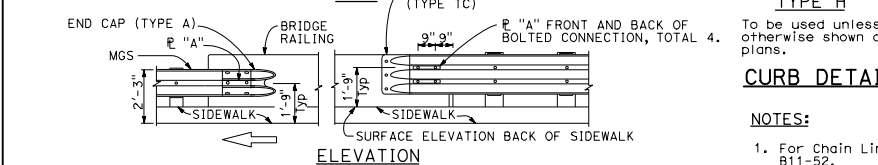
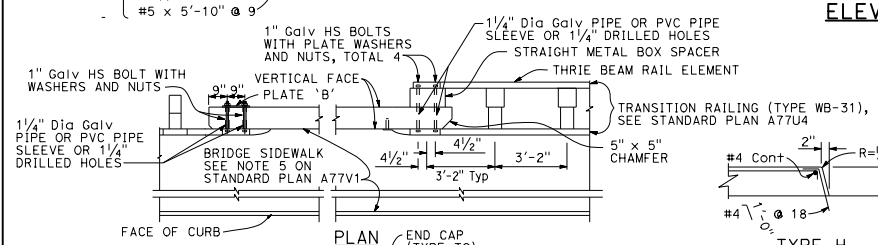
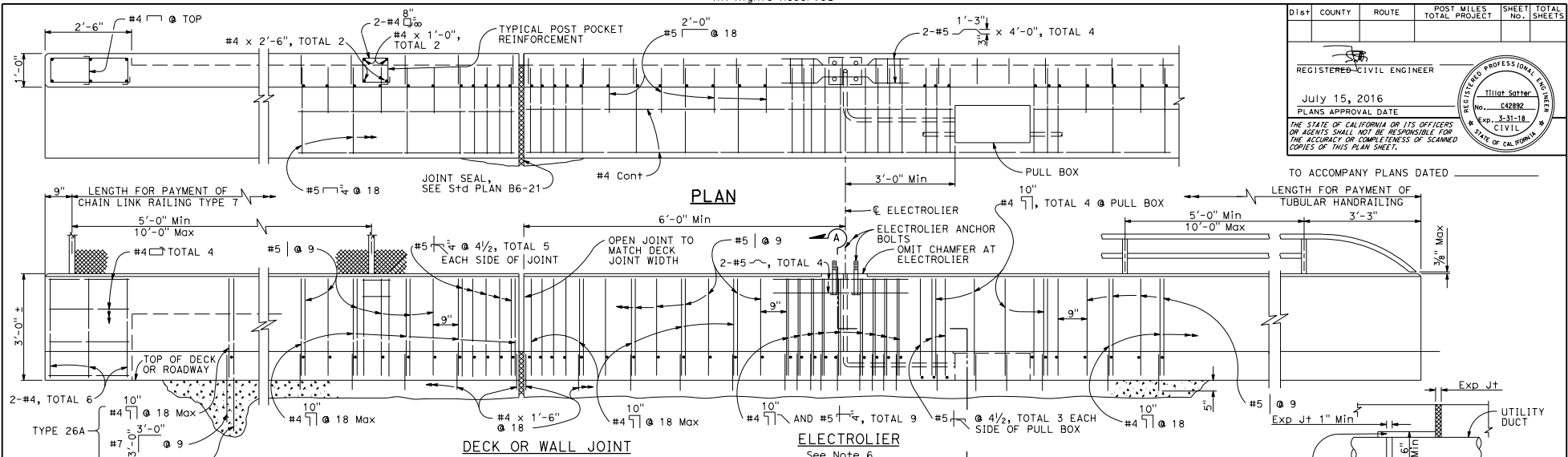

- NOTES:**
- For Chain Link Railing notes and details not shown, see Standard Plan B11-52.
 - For Handrailing notes and details not shown, see Revised Standard Plan RSP B11-51.
 - Dimensions will vary with cross slope and with certain thicknesses of surfacing. See Project Plans.
 - Walls are to be backfilled before railing is placed.
 - Clearance to reinforcing steel in curb and railing to be 1" except as noted. Longitudinal reinforcement to stop at all expansion joints.
 - See Project Plans for electrolier locations and pull box type.
 - For electrical details, see Standard Plans ES-9A, ES-9B, Revised Standard Plans RSP ES-9C, RSP ES-9D and RSP ES-9E.
 - A maximum of five - 4" and a minimum of two - 4" round openings for future utilities. Openings are to be sealed at ends and extended 8" minimum past end of sidewalk if not used. Duct forms are to be tied down. Minimum of 6" from face of rail to utility opening. See Standard Plan B14-3 for minimum spacing between conduit, and for details at joints.
 - For typical metal railing connection details not shown, see Standard Plans A77V1 and A77V2.
 - This barrier is to be used only for speeds of 45 MPH or less. For speeds greater than 45 MPH, pedestrians should be protected by a separation traffic barrier.

STATE OF CALIFORNIA
DEPARTMENT OF TRANSPORTATION
CONCRETE BARRIER TYPE 26
NO SCALE
RSP B11-54 DATED JULY 15, 2016 SUPERSEDES STANDARD PLAN B11-54
DATED OCTOBER 30, 2015 - PAGE 314 OF THE STANDARD PLANS BOOK DATED 2015.
REVISED STANDARD PLAN RSP B11-54

2015 REVISED STANDARD PLAN RSP B11-54

DIST	COUNTY	ROUTE	POST MILES TOTAL PROJECT	SHEET TOTAL SHEETS

REGISTERED CIVIL ENGINEER	
July 15, 2016	
PLANS APPROVAL DATE	
THE STATE OF CALIFORNIA OR ITS OFFICERS OR AGENTS SHALL NOT BE RESPONSIBLE FOR THE ACCURACY OR COMPLETENESS OF SCANNED COPIES OF THIS PLAN SHEET.	
TO ACCOMPANY PLANS DATED _____	

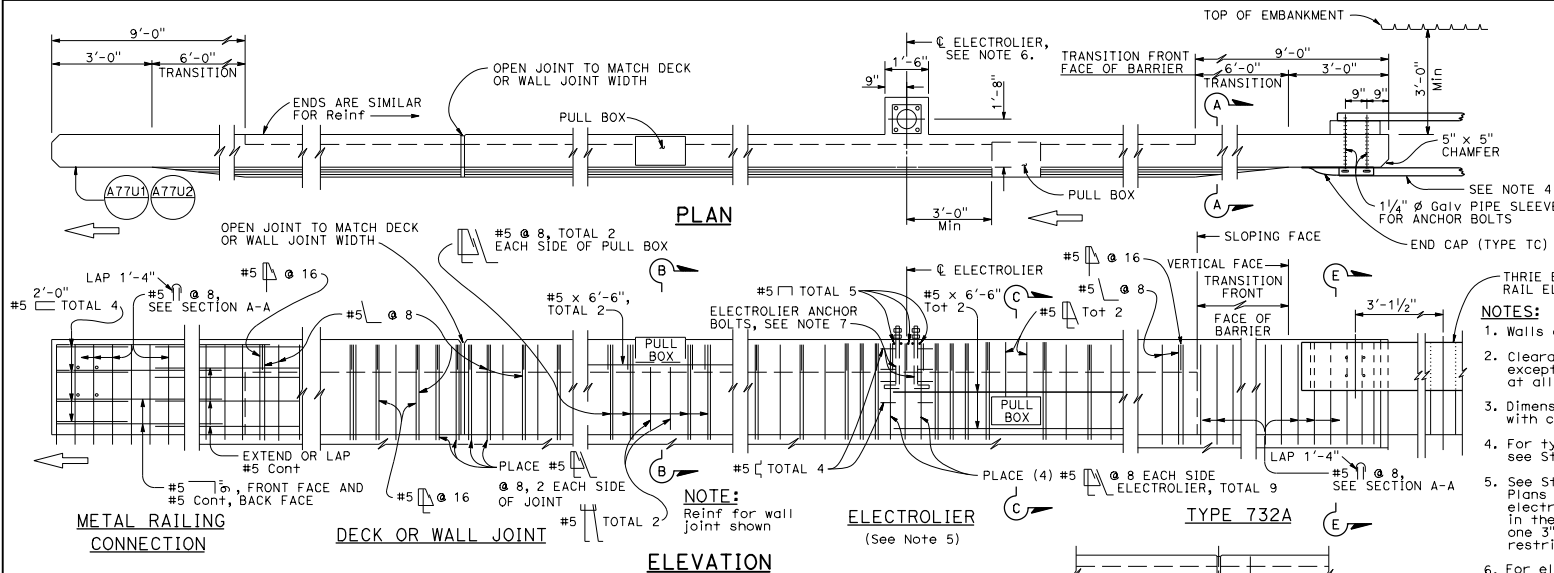

- NOTES:**
- Walls are to be backfilled before barrier is placed.
 - Clearance to reinforcing steel in barrier to be 1", except as noted. Longitudinal reinforcement to stop at all expansion joints.
 - Dimensions may vary with roadway cross slope and with certain thickness of surfacing. See Project Plans.
 - For typical metal railing connection details not shown, see Standard Plans AT7U1 and AT7U2.
 - See Standard Plans ES-9A, ES-9B, Revised Standard Plans RSP ES-9C, RSP ES-9D, and RSP ES-9E for electrical details. The maximum number of conduits in the barrier is limited to two 2" conduits along with one 3" conduit. When a 3" conduit is used, it is restricted to the base of the barrier.
 - For electrolier mounting details, See Revised Standard Plans RSP ES-6A and RSP ES-6B.
 - Minimum concrete edge distance, to the reinforcing shown, shall be maintained. Edge distance may be adjusted to accommodate increase in concrete cover for architectural treatment.

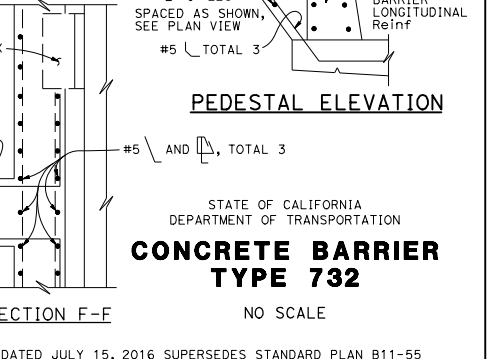
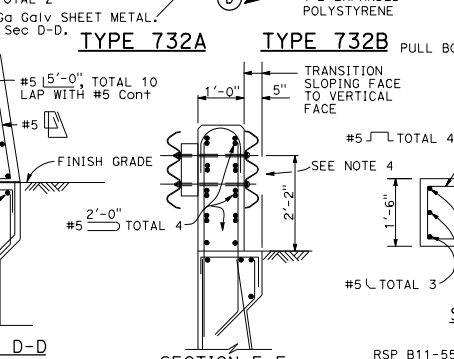
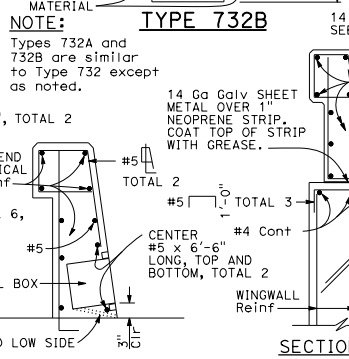
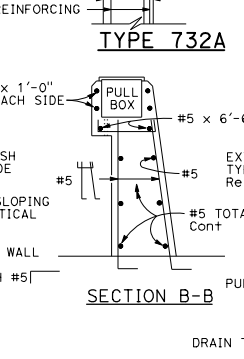
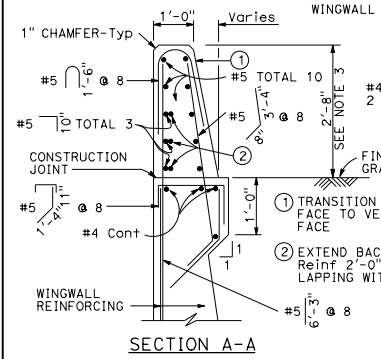
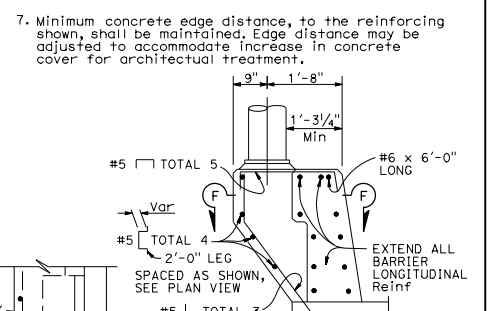
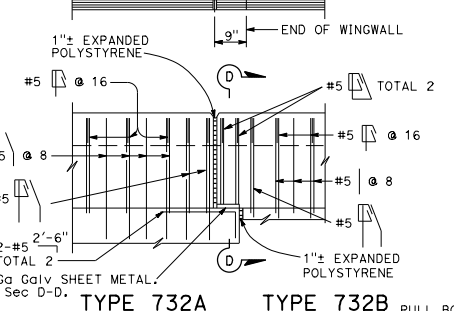
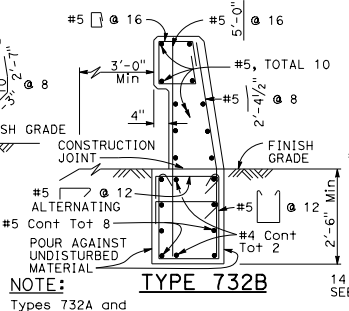
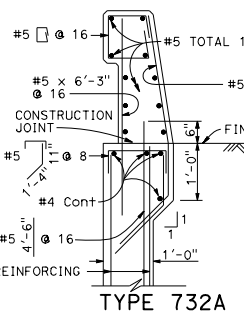
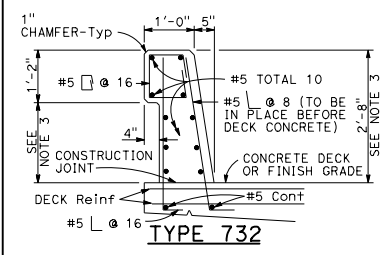

Details shown for barrier anchorage to Type 732A. Anchorage for barrier Types 732 and 732A are similar to their respective details.

RSP B11-55 DATED JULY 15, 2016 SUPERSEDES STANDARD PLAN B11-55 DATED OCTOBER 30, 2015 - PAGE 315 OF THE STANDARD PLANS BOOK DATED 2015.

REVISED STANDARD PLAN RSP B11-55

2015 REVISED STANDARD PLAN RSP B11-55

DIST	COUNTY	ROUTE	POST MILES TOTAL PROJECT	SHEET TOTAL SHEETS

REGISTERED CIVIL ENGINEER
 Tiliot Sattler
 No. C42892
 Exp. 3-31-18
 CIVIL
 STATE OF CALIFORNIA

July 15, 2016
 PLANS APPROVAL DATE

THE STATE OF CALIFORNIA OR ITS OFFICERS OR AGENTS SHALL NOT BE RESPONSIBLE FOR THE ACCURACY OR COMPLETENESS OF SCANNED COPIES OF THIS PLAN SHEET.

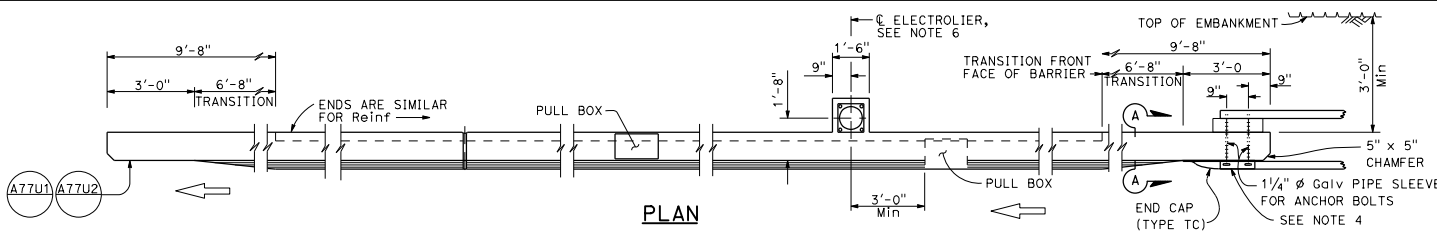

PLAN

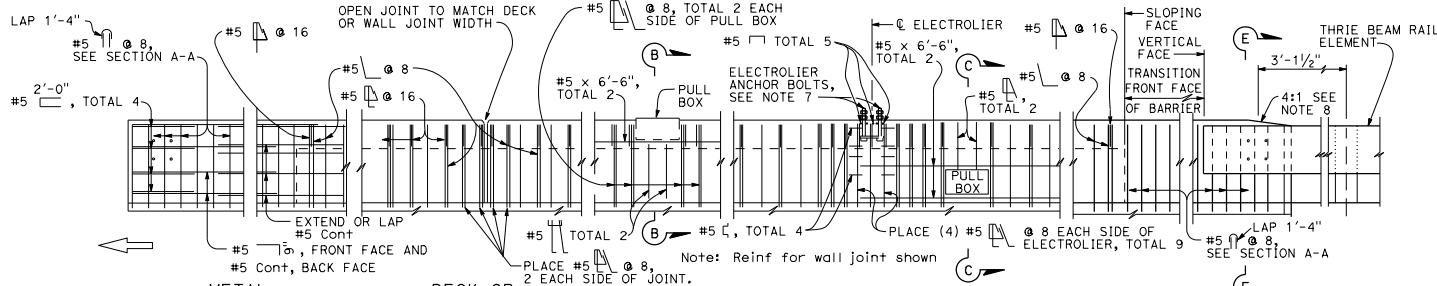

ELEVATION

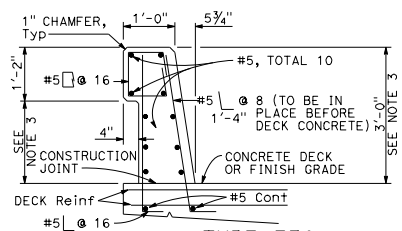

TYPE 736

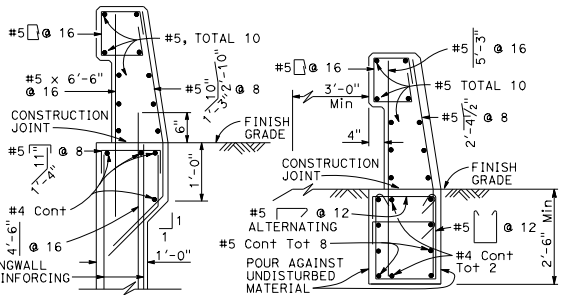

TYPE 736A

TYPE 736B

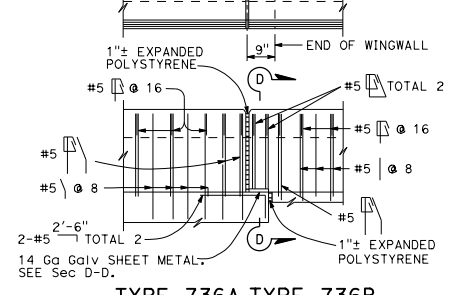

TYPE 736A TYPE 736B

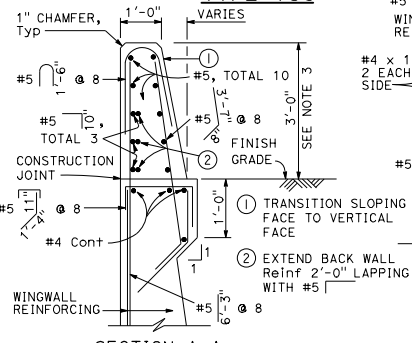

SECTION A-A

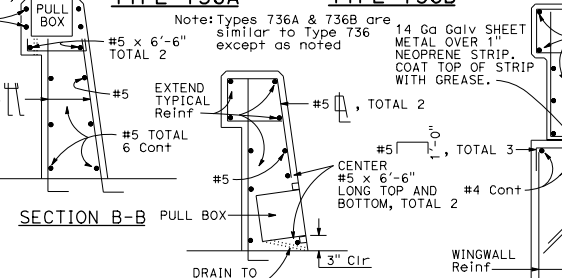

SECTION B-B

SECTION C-C

SECTION D-D

SECTION E-E

Details shown for barrier anchorage to Type 736A. Anchorages for barrier Types 736 and 736B are similar to their respective details.

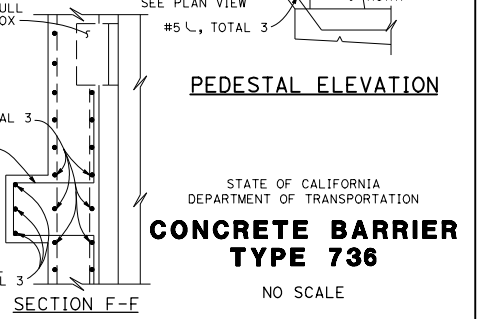
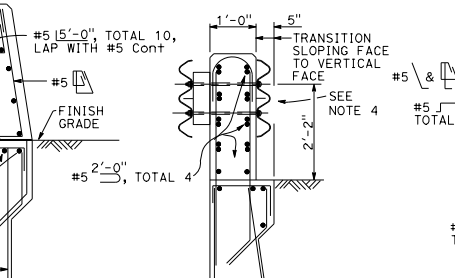

PEDESTAL ELEVATION

SECTION F-F

STATE OF CALIFORNIA
DEPARTMENT OF TRANSPORTATION
**CONCRETE BARRIER
TYPE 736**
NO SCALE

- NOTES:
1. Walls are to be backfilled before barrier is placed.
 2. Clearance to reinforcing steel in barrier to be 1", except as noted. Longitudinal reinforcement to stop at all expansion joints.
 3. Dimensions may vary with roadway cross slope and with certain thickness of surfacing. See Project Plans.
 4. For typical metal railing connection details not shown, see Standard Plans A77U1 and A77U2.
 5. See Standard Plans ES-9A, ES-9B, Revised Standard Plans RSP ES-9C, RSP ES-9D and RSP ES-9E for electrical details. The maximum number of conduits in the barrier is limited to two 2" conduits along with one 3" conduit. When a 3" conduit is used, it is restricted to the base of the barrier.
 6. For electrolier mounting details, See Revised Standard Plans RSP ES-6A and RSP ES-6B.
 7. Minimum concrete edge distance, to the reinforcing shown, shall be maintained. Edge distance may be adjusted to accommodate increase in concrete cover for architectural treatment.
 8. Taper the top of the end of the bridge railing at 4:1 to match the top elevation of the thrie beam rail element.

RSP B11-56 DATED JULY 15, 2016 SUPERSEDES STANDARD PLAN B11-56 DATED OCTOBER 30, 2015 - PAGE 316 OF THE STANDARD PLANS BOOK DATED 2015.

REVISED STANDARD PLAN RSP B11-56

2015 REVISED STANDARD PLAN RSP B11-56

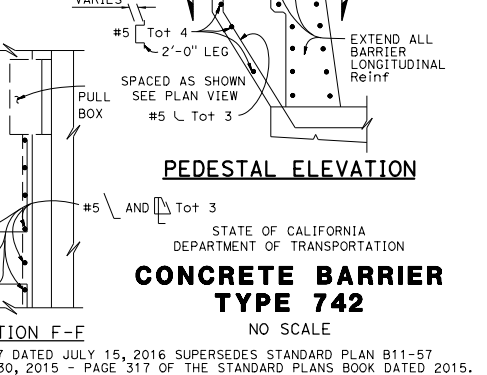
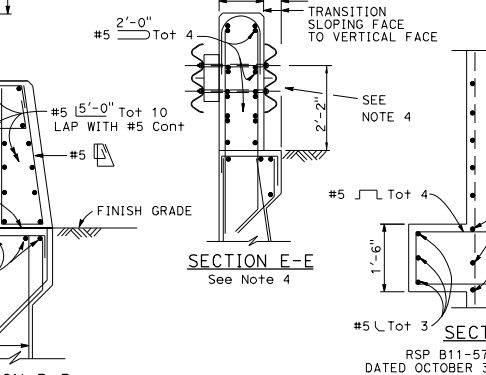
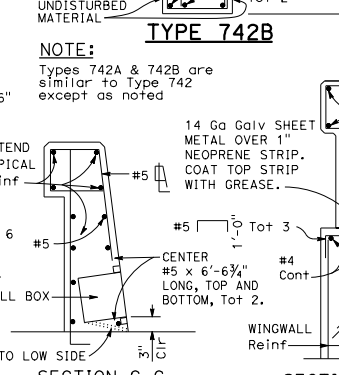
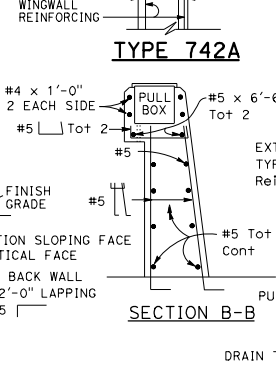
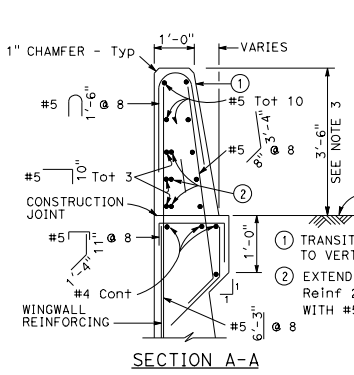
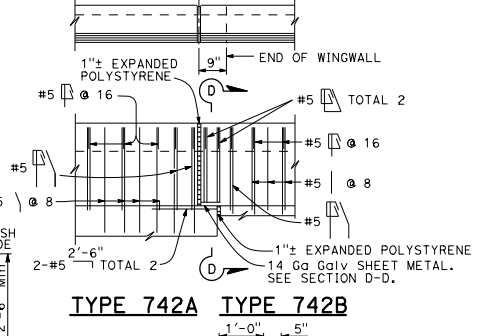
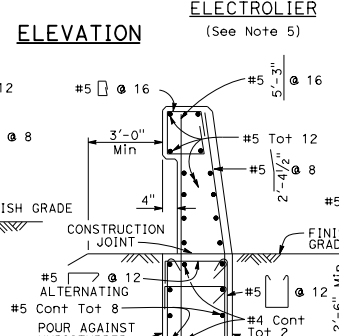
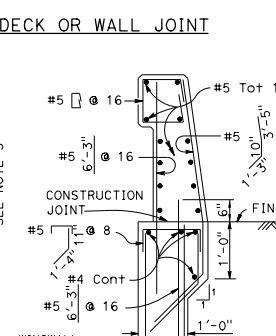
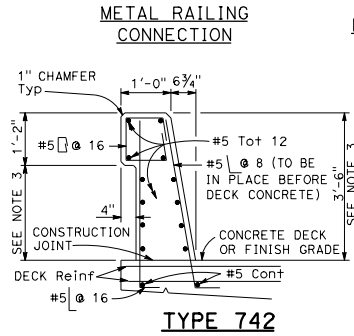
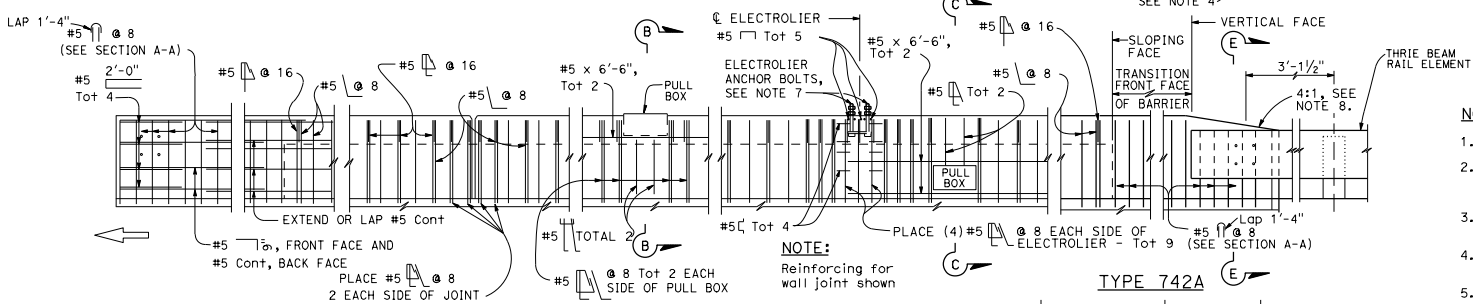
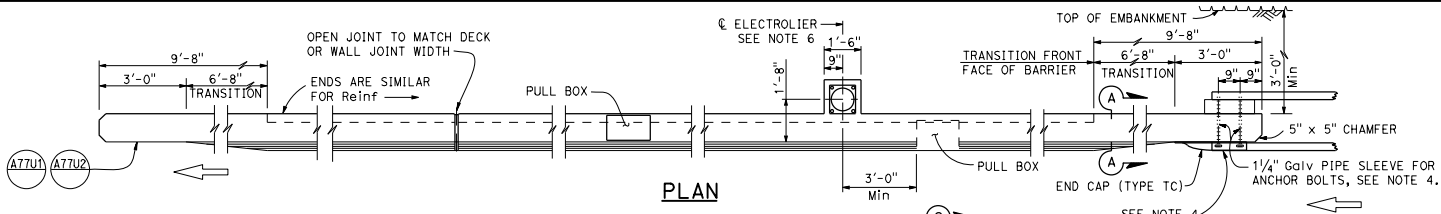

Details shown for barrier anchorage to Type 742A. Anchorage for barrier Types 742 and 742A are similar to their respective details.

SECTION C-C See Notes

SECTION D-D

DIST	COUNTY	ROUTE	POST MILES TOTAL PROJECT	SHEET TOTAL SHEETS

REGISTERED CIVIL ENGINEER
Tillot Satter
No. C42892
PLANS APPROVAL DATE
JULY 15, 2016
THE STATE OF CALIFORNIA OR ITS OFFICERS OR AGENTS SHALL NOT BE RESPONSIBLE FOR THE ACCURACY OR COMPLETENESS OF SCANNED COPIES OF THIS PLAN SHEET.

- NOTES:
1. Walls are to be backfilled before barrier is placed.
 2. Clearance to reinforcing steel in barrier to be 1", except as noted. Longitudinal reinforcement to stop at all expansion joints.
 3. Dimensions may vary with roadway cross slope and with certain thickness of surfacing. See Project Plans.
 4. For typical metal railing connection details not shown, see Standard Plans A77U1 and A77U2.
 5. See Standard Plans ES-9A, ES-9B, Revised Standard Plans RSP ES-9C, RSP ES-9D and RSP ES-9E for electrical details. The maximum number of conduits in the barrier is limited to two 2" conduits along with one 3" conduit. When a 3" conduit is used, it is restricted to the base of the barrier.
 6. For electrolier mounting details, see Revised Standard Plans RSP ES-6A and RSP ES-6B.
 7. Minimum concrete edge distance, to the reinforcing shown, shall be maintained. Edge distance may be adjusted to accommodate increase in concrete cover for architectural treatment.
 8. Taper the top of the end of the bridge railing at 4:1 to match the top elevation of the thrie beam rail element.

STATE OF CALIFORNIA
DEPARTMENT OF TRANSPORTATION
**CONCRETE BARRIER
TYPE 742**
NO SCALE

RSP B11-57 DATED JULY 15, 2016 SUPERSEDES STANDARD PLAN B11-57
DATED OCTOBER 30, 2015 - PAGE 317 OF THE STANDARD PLANS BOOK DATED 2015.
REVISED STANDARD PLAN RSP B11-57

2015 REVISED STANDARD PLAN RSP B11-57

DIST	COUNTY	ROUTE	POST MILES TOTAL PROJECT	SHEET TOTAL SHEETS

REGISTERED CIVIL ENGINEER	
July 21, 2017	
PLANS APPROVAL DATE	
Tillot Satter	
No. C42892	
EXP. 3-31-18	
CIVIL	
STATE OF CALIFORNIA	

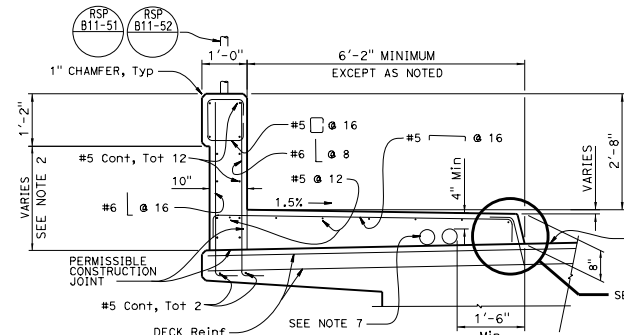

SECTION A-A
TYPICAL SECTION ON DECK

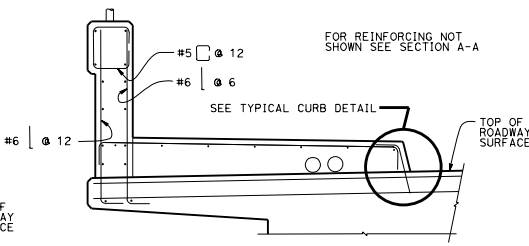

SECTION B-B
TYPICAL SECTION AT JOINTS

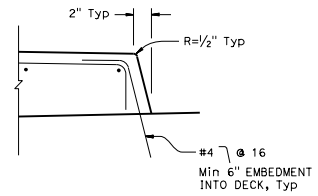

TYPICAL CURB DETAIL

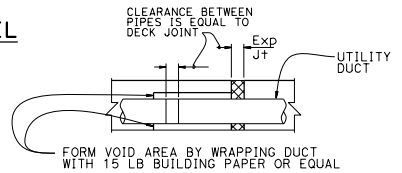

UTILITY DUCT EXPANSION JOINT

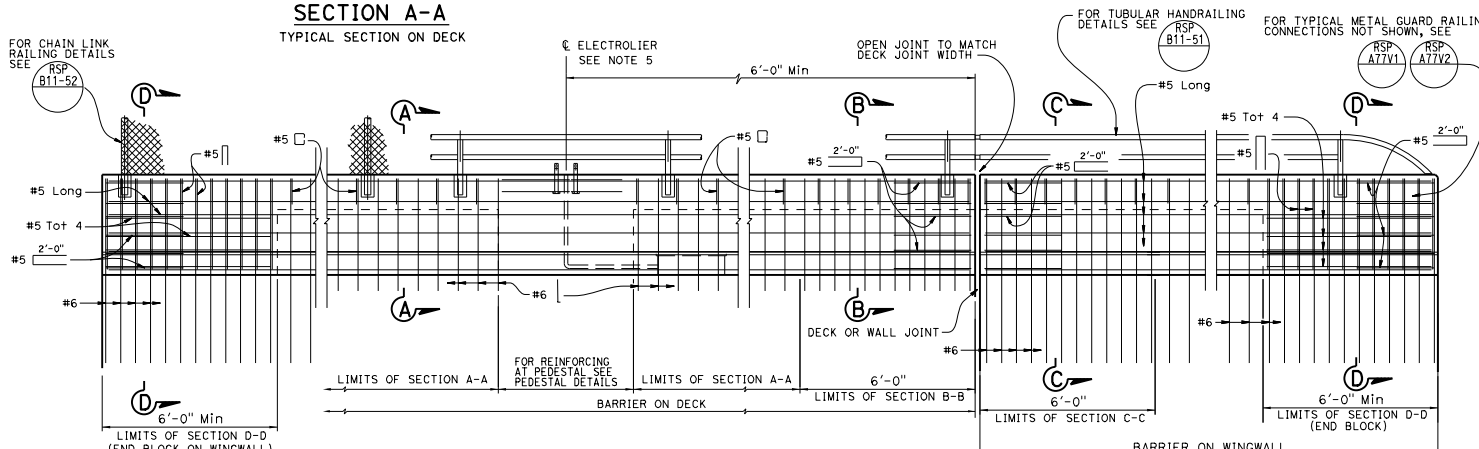

ELEVATION

NOTES:

1. This barrier is to be used only for posted speeds of 45 MPH or less. For speeds greater than 45 MPH, pedestrians must be protected by a separation traffic barrier.
2. Dimensions will vary with cross slope and surfacing thickness. See Project Plans.
3. Walls must be backfilled before curb and parapet is placed.
4. Clearance to reinforcing steel in curb and railing is 2" except as noted. Longitudinal reinforcement to stop at all expansion joints.
5. See Project Plans for electrolier locations and pull box type.
6. For electrical details, see Standard Plans ES-9A, ES-9B, Revised Standard Plans RSP ES-9C, RSP ES-9D, and RSP ES-9E.
7. A minimum of two - 4" round openings for future utilities. A maximum six - 4" round openings for a 6'-2" sidewalk. One - 4" round opening can be added for each additional 1'-0" of sidewalk width. Utility opening must be a minimum of 6" from face of barrier parapet. Openings are to be sealed at ends and extended 8" minimum past end of sidewalk if not used. Duct forms are to be tied down. For exact number and placement of utility openings see other details. Minimum 2" clear between conduits.
8. See Project Plans for "Joint Armor For Pedestrian Walkways" details.
9. Tubular hand railing and chain link railing continuous at pedestal.
10. For details and reinforcement not shown, see Revised Standard Plan RSP B11-59.

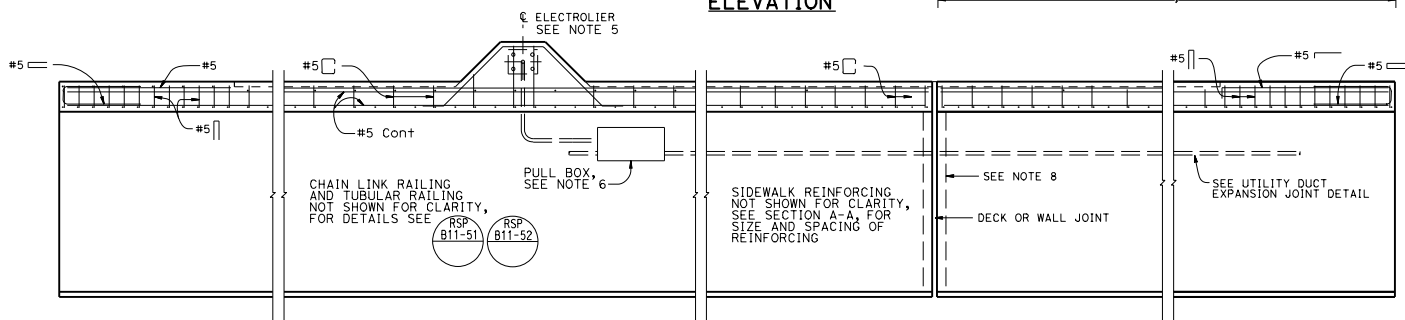

PLAN

STATE OF CALIFORNIA
DEPARTMENT OF TRANSPORTATION
**CONCRETE BARRIER
TYPE 732SW
(SHEET 1 OF 2)**

NO SCALE

RSP B11-58 DATED JULY 21, 2017 SUPERSEDES RSP B11-58 DATED JANUARY 20, 2017 THAT SUPPLEMENTS THE STANDARD PLANS BOOK DATED 2015.

REVISED STANDARD PLAN RSP B11-58

2015 REVISED STANDARD PLAN RSP B11-58

Dist	COUNTY	ROUTE	POST MILES TOTAL PROJECT	SHEET TOTAL NO. SHEETS

REGISTERED CIVIL ENGINEER
Tillot Satter
No. C42892
PLANS APPROVAL DATE July 21, 2017
EXP. 3-31-18
CIVIL
STATE OF CALIFORNIA

THE STATE OF CALIFORNIA OR ITS OFFICERS OR AGENTS SHALL NOT BE RESPONSIBLE FOR THE ACCURACY OR COMPLETENESS OF SCANNED COPIES OF THIS PLAN SHEET.

TO ACCOMPANY PLANS DATED _____

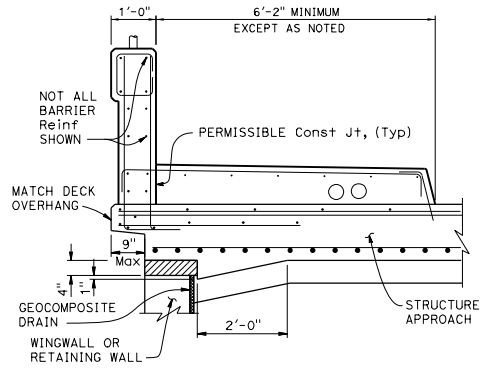

TYPE E-1

WITH STRUCTURE APPROACH

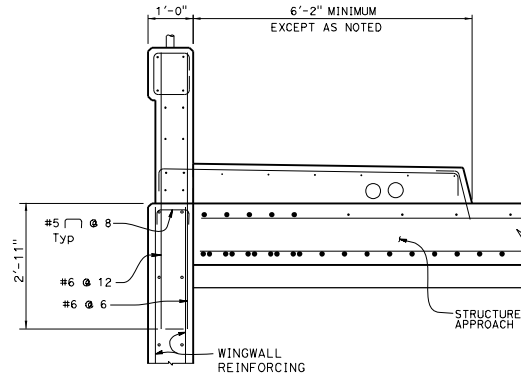

TYPE E-2

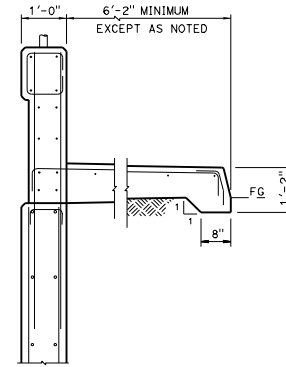

WITHOUT STRUCTURE APPROACH

LEGEND:

Indicates Expanded Polystyrene, remove after concrete is placed.

NOTE:

1. For details not shown, see Revised Standard Plan RSP B11-58.

SECTION C-C

For details not shown see SECTION B-B

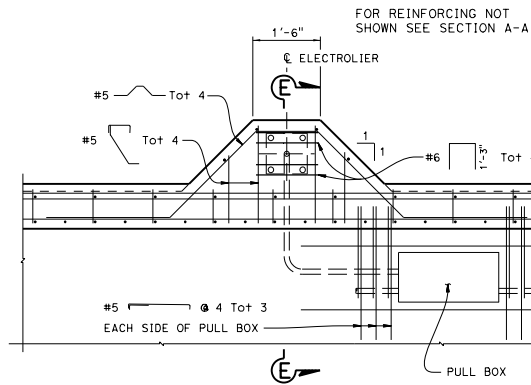

PEDESTAL PLAN

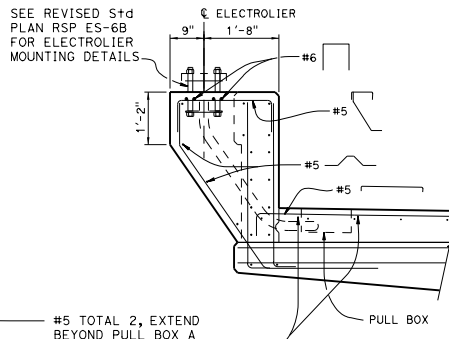

PEDESTAL DETAILS

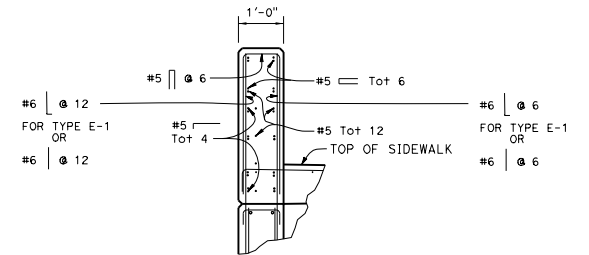

NOTE:
FOR SIDEWALK, STRUCTURE APPROACH, WINGWALL OR RETAINING WALL SEE SECTION C-C

SECTION D-D
END BLOCK

STATE OF CALIFORNIA
DEPARTMENT OF TRANSPORTATION
CONCRETE BARRIER
TYPE 732SW
(SHEET 2 OF 2)

NO SCALE

RSP B11-59 DATED JULY 21, 2017 SUPERSEDES RSP B11-59 DATED JANUARY 20, 2017 THAT SUPPLEMENTS THE STANDARD PLANS BOOK DATED 2015.

REVISED STANDARD PLAN RSP B11-59

2015 REVISED STANDARD PLAN RSP B11-59

DIST	COUNTY	ROUTE	POST MILES TOTAL PROJECT	SHEET TOTAL SHEETS

REGISTERED CIVIL ENGINEER	
July 15, 2016	
PLANS APPROVAL DATE	
<small>THE STATE OF CALIFORNIA OR ITS OFFICERS OR AGENTS SHALL NOT BE RESPONSIBLE FOR THE ACCURACY OR COMPLETENESS OF SCANNED COPIES OF THIS PLAN SHEET.</small>	

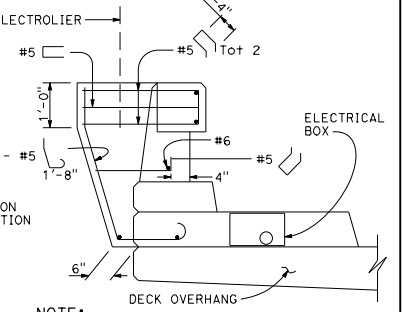
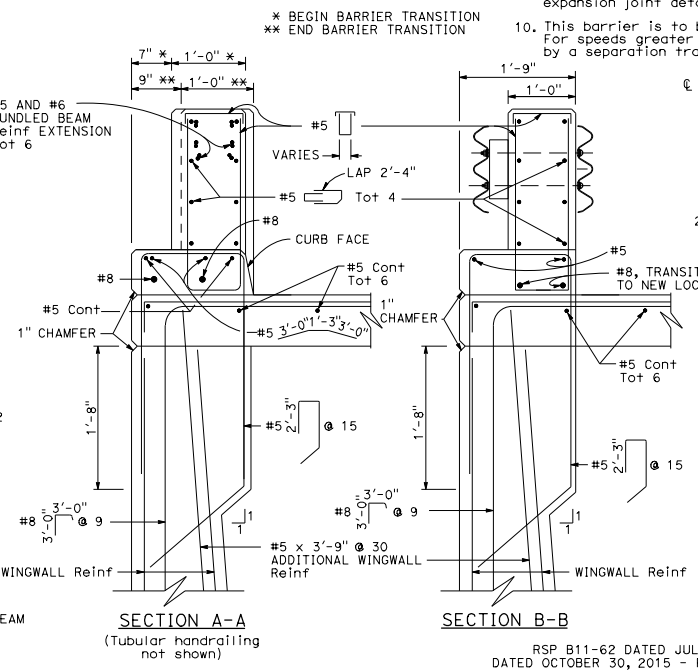
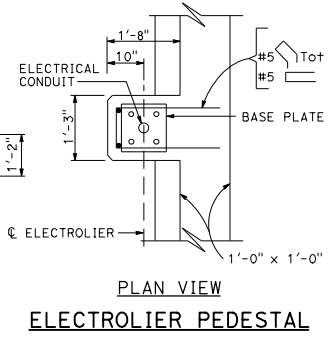
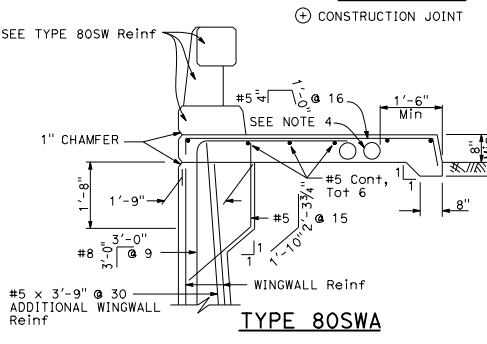
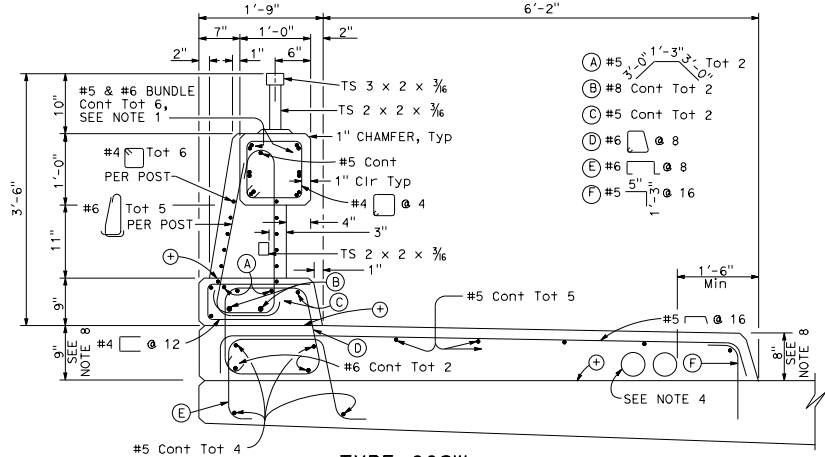
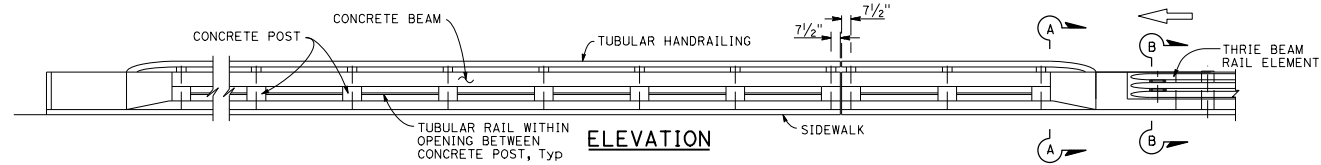
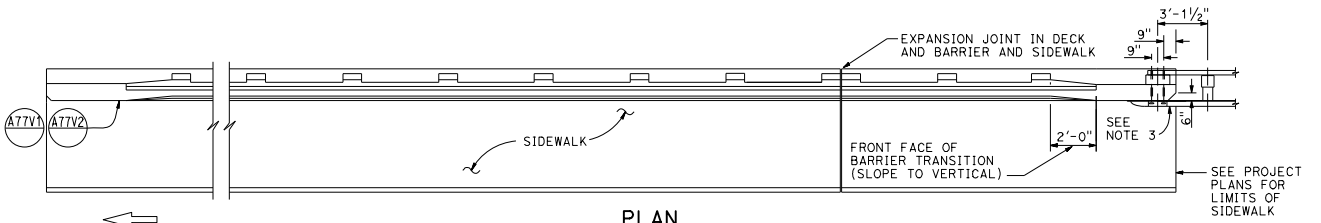

- NOTES:**
- No lap splicing allowed on the longitudinal rail reinforcing. Splicing shall be staggered.
 - For electrical details, see Standard Plans ES-9A, ES-9B, Revised Standard Plans RSP ES-9C, RSP ES-9D and RSP ES-9E. See Project Plans for electrical layout.
 - For typical metal railing connection details not shown, see Standard Plans A77V1 and A77V2.
 - A maximum of five - 4" and a minimum of two - 4" round openings for future utilities. Openings are to be sealed at ends and extended 8" minimum past end of sidewalk if not used. Duct forms are to be tied down. Minimum of 6" from face of rail to utility opening. See Standard Plan B14-3 for minimum spacing between conduits and for conduit details at joints.
 - Chain link railing is not allowed on Type 80SW Barrier.
 - Walls are to be backfilled before railing is placed.
 - Terminate all longitudinal curb, sidewalk, and deck reinforcement in standard 90° hooks.
 - Dimensions will vary with cross slope and with certain thickness of surfacing.
 - Expansion joint to match deck joint, see Standard Plan B11-63 for expansion joint details.
 - This barrier is to be used only for speeds of 45 MPH or less. For speeds greater than 45 MPH, pedestrians should be protected by a separation traffic barrier.

NOTE:
Pedestal design for 1'-0" base plate.

BARRIER MODIFICATION FOR ELECTROLIER

STATE OF CALIFORNIA
DEPARTMENT OF TRANSPORTATION

CONCRETE BARRIER TYPE 80SW (SHEET 1 OF 3)
NO SCALE

RSP B11-62 DATED JULY 15, 2016 SUPERSEDES STANDARD PLAN B11-62 DATED OCTOBER 30, 2015 - PAGE 320 OF THE STANDARD PLANS BOOK DATED 2015.

REVISED STANDARD PLAN RSP B11-62

2015 REVISED STANDARD PLAN RSP B11-62

DIST	COUNTY	ROUTE	POST MILES TOTAL PROJECT	SHEET TOTAL NO. SHEETS
REGISTERED CIVIL ENGINEER July 15, 2016 PLANS APPROVAL DATE THE STATE OF CALIFORNIA OR ITS OFFICERS OR AGENTS SHALL NOT BE RESPONSIBLE FOR THE ACCURACY OR COMPLETENESS OF SCANNED COPIES OF THIS PLAN SHEET.				

TO ACCOMPANY PLANS DATED _____

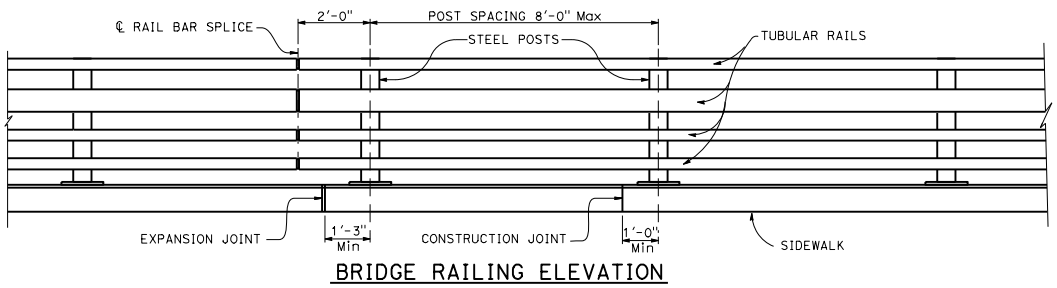

BRIDGE RAILING ELEVATION

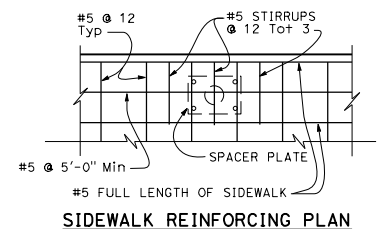

SIDEWALK REINFORCING PLAN

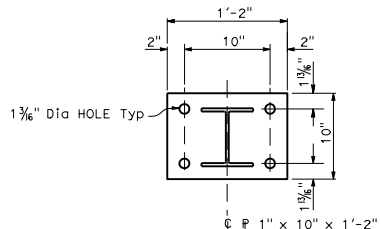

POST BASE PLATE PLAN

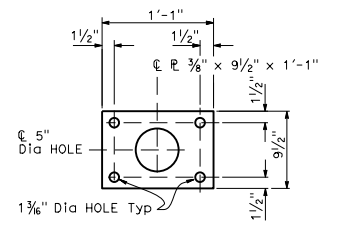

SPACER PLATE PLAN

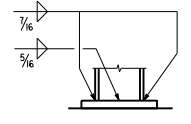

POST BASE WELD DETAIL

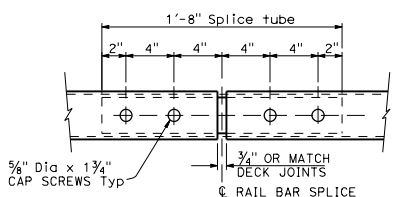

BOTTOM VIEW RAIL BAR SPLICE DETAIL

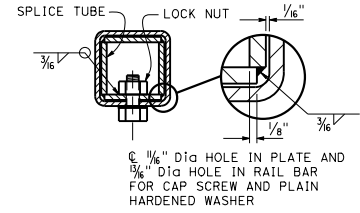

RAIL BAR SPLICE SECTION

NOTES:

- All exposed cuts or sheared edges shall be rounded and free of burrs.
- Rail posts shall be set normal to grade.
- Lengths of rail bar shall be attached to a minimum of two rail posts.
- Rail post anchoring nuts shall be tightened to a snug fit and given additional 1/8 turn.
- Holes in posts for rail bar attachment may be field drilled. Holes shall be coated with an approved zinc-rich paint prior to erection.
- This barrier is to be used only for speeds of 45 mph or less. For speeds greater than 45 mph, pedestrians should be protected by a separation traffic barrier.
- A maximum of six - 4" and a minimum of two - 4" round openings for future utilities. Openings are to be sealed at ends and extended 8" minimum past end of sidewalk if not used. Duct forms are to be tied down. Round openings are to be a minimum of 1'-6" from face of sidewalk curb and a minimum of 6" from face of rail. See Standard Plan B14-3 for minimum spaces between conduits and for conduit details at joints.

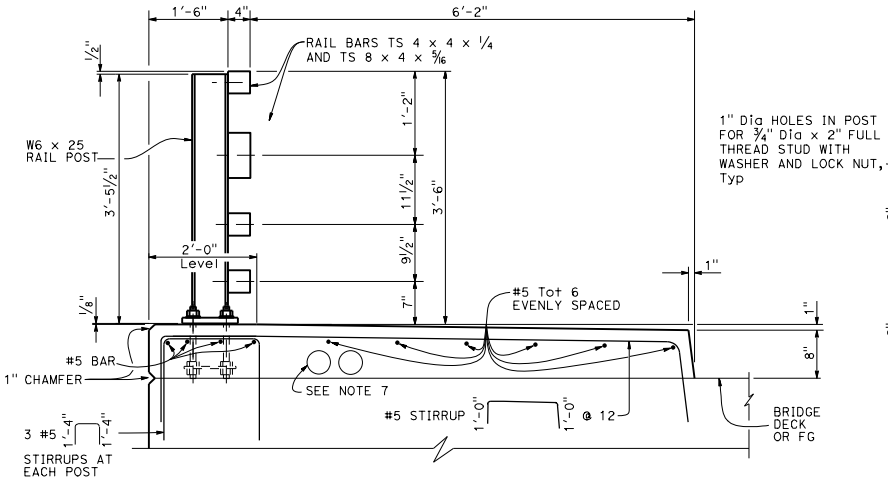

TYPICAL SECTION

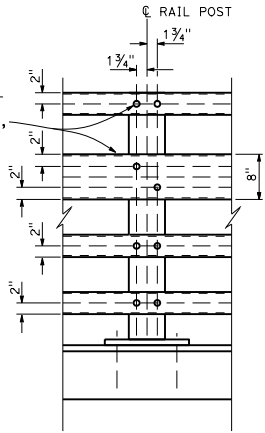

ELEVATION

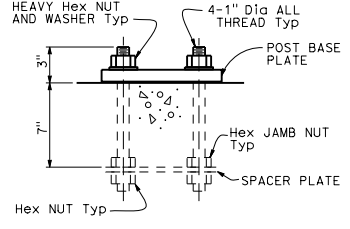

RAIL POST ANCHORAGE

STATE OF CALIFORNIA
DEPARTMENT OF TRANSPORTATION
**CALIFORNIA ST-40
BRIDGE RAIL
(SHEET 1 OF 2)**
NO SCALE

2015 REVISED STANDARD PLAN RSP B11-66

DIST	COUNTY	ROUTE	POST MILES TOTAL PROJECT	SHEET TOTAL SHEETS

REGISTERED CIVIL ENGINEER

July 15, 2016

PLANS APPROVAL DATE

THE STATE OF CALIFORNIA OR ITS OFFICERS OR AGENTS SHALL NOT BE RESPONSIBLE FOR THE ACCURACY OR COMPLETENESS OF SCANNED COPIES OF THIS PLAN SHEET.

REGISTERED PROFESSIONAL ENGINEER
Tillot Satter
No. C42892
Exp. 3-31-18
CIVIL
STATE OF CALIFORNIA

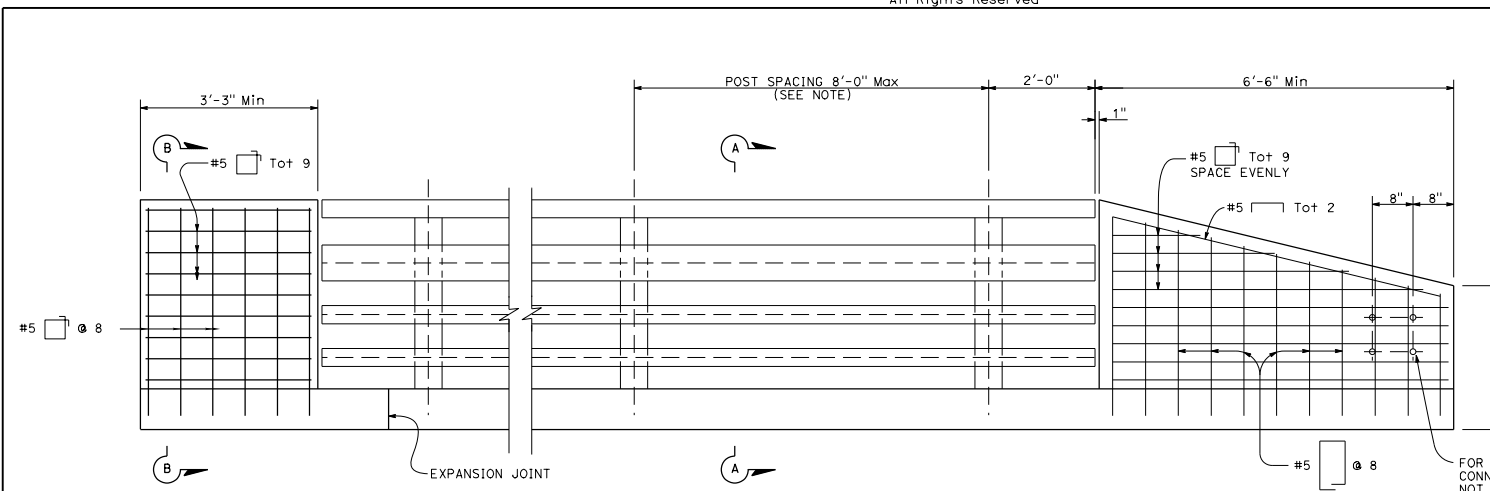

END OF RAILING ELEVATION

FOR METAL RAILING CONNECTION DETAILS NOT SHOWN, SEE STANDARD PLANS A77V1 AND A77V2.

TO ACCOMPANY PLANS DATED _____

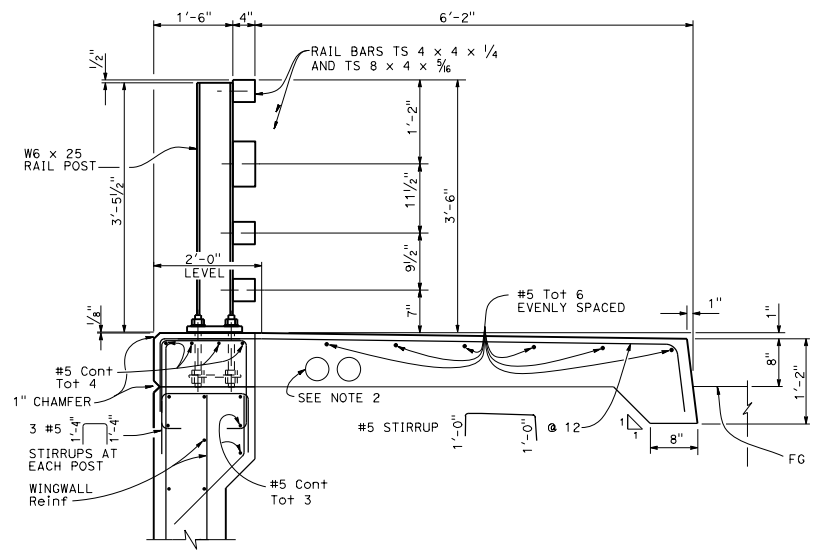

SECTION A-A

For details not shown, see Typical Section

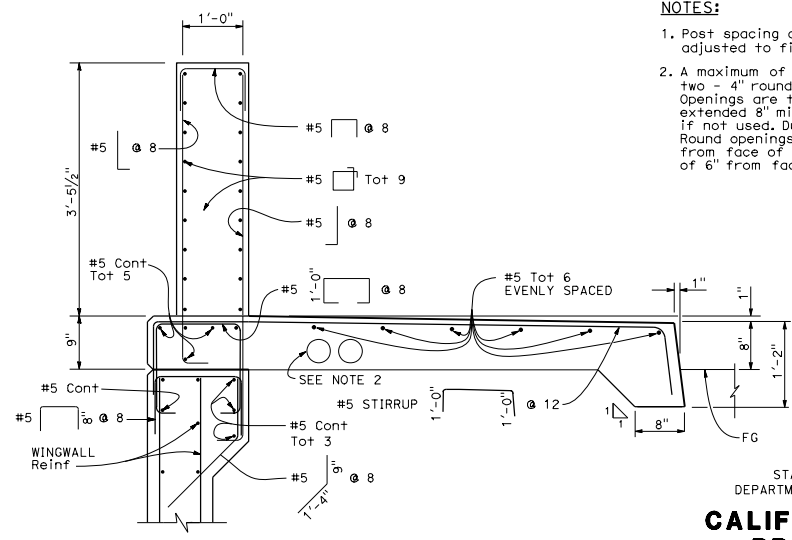

SECTION B-B

For details not shown, see Typical Section

NOTES:

1. Post spacing and/or end block length to be adjusted to fit bridge length or wingwall length.
2. A maximum of six - 4" and a minimum of two - 4" round openings for future utilities. Openings are to be sealed at ends and extended 8" minimum past end of sidewalk if not used. Duct forms are to be tied down. Round openings are to be a minimum of 1'-6" from face of sidewalk curb and a minimum of 6" from face of rail.

STATE OF CALIFORNIA
DEPARTMENT OF TRANSPORTATION
**CALIFORNIA ST-40
BRIDGE RAIL
(SHEET 2 OF 2)**

NO SCALE

RSP B11-67 DATED JULY 15, 2016 SUPERSEDES STANDARD PLAN B11-67
DATED OCTOBER 30, 2015 - PAGE 325 OF THE STANDARD PLANS BOOK DATED 2015.
REVISED STANDARD PLAN RSP B11-67

2015 REVISED STANDARD PLAN RSP B11-67

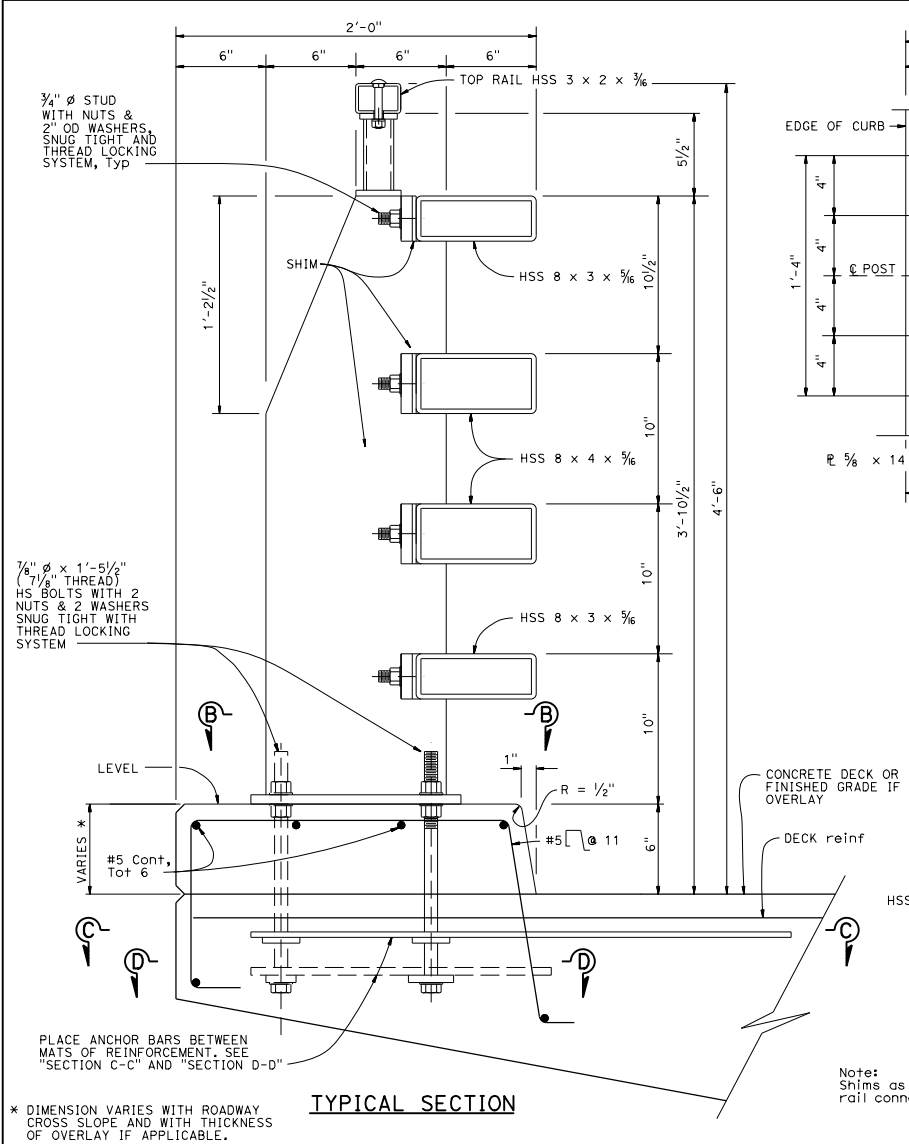

TYPICAL SECTION

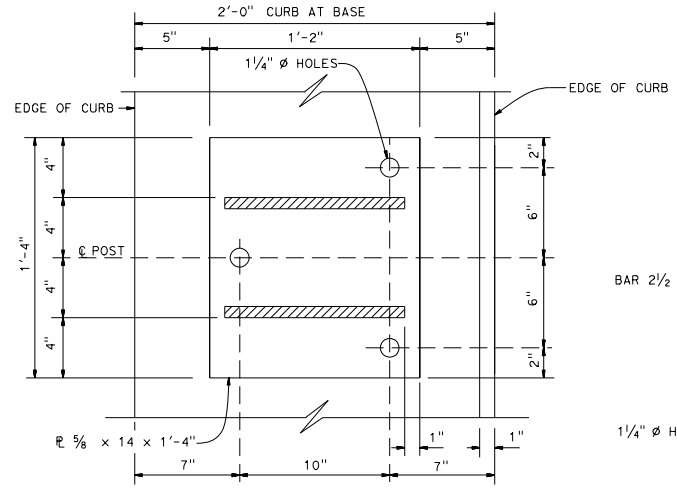

SECTION B-B

DIST	COUNTY	ROUTE	POST MILES TOTAL PROJECT	SHEET NO.	TOTAL SHEETS

Gregory J. Kaderbek
 REGISTERED CIVIL ENGINEER
 No. C40814
 Exp. 3-31-17
 CIVIL
 STATE OF CALIFORNIA

July 15, 2016
 PLANS APPROVAL DATE
 THE STATE OF CALIFORNIA OR ITS OFFICERS OR AGENTS SHALL NOT BE RESPONSIBLE FOR THE ACCURACY OR COMPLETENESS OF SCANNED COPIES OF THIS PLAN SHEET.

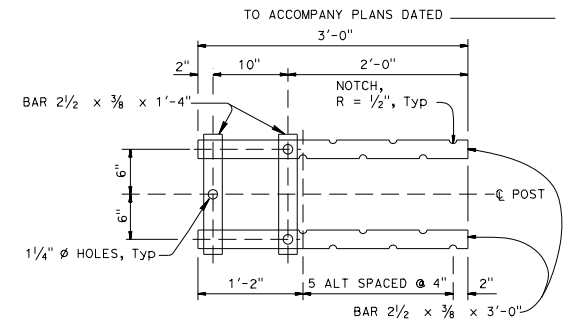

SECTION C-C

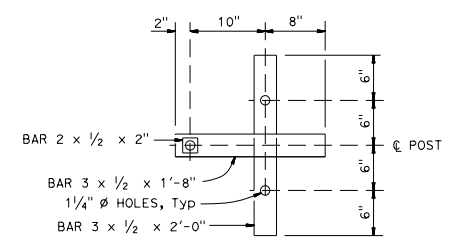

SECTION D-D

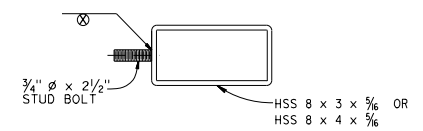

RAIL SECTION AT POST

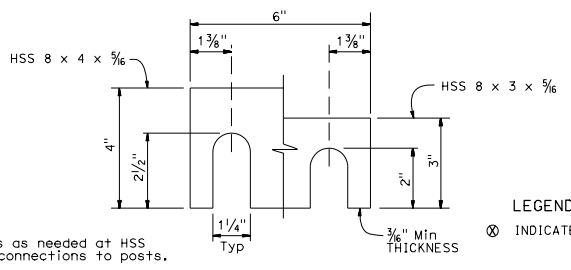

SHIM DETAIL

Note: Shims as needed at HSS rail connections to posts.

LEGEND:

⊗ INDICATES STUD WELD

STATE OF CALIFORNIA
 DEPARTMENT OF TRANSPORTATION
CALIFORNIA ST-20S BRIDGE RAIL
(SHEET 1 OF 4)
 NO SCALE

RSP B11-71 DATED JULY 15, 2016 SUPPLEMENTS THE STANDARD PLANS BOOK DATED 2015.

REVISED STANDARD PLAN RSP B11-71

2015 REVISED STANDARD PLAN RSP B11-71

DIST	COUNTY	ROUTE	POST MILES TOTAL PROJECT	SHEET TOTAL SHEETS

Gregory J. Koberg
 REGISTERED CIVIL ENGINEER

July 15, 2016
 PLANS APPROVAL DATE

THE STATE OF CALIFORNIA OR ITS OFFICERS OR AGENTS SHALL NOT BE RESPONSIBLE FOR THE ACCURACY OR COMPLETENESS OF SCANNED COPIES OF THIS PLAN SHEET.

REGISTERED PROFESSIONAL ENGINEER
 Gregory J. Koberg
 No. C40814
 Exp. 3-31-17
 CIVIL
 STATE OF CALIFORNIA

TO ACCOMPANY PLANS DATED _____

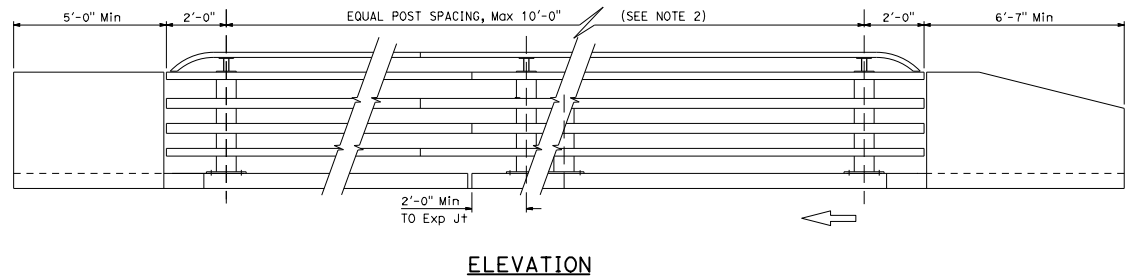
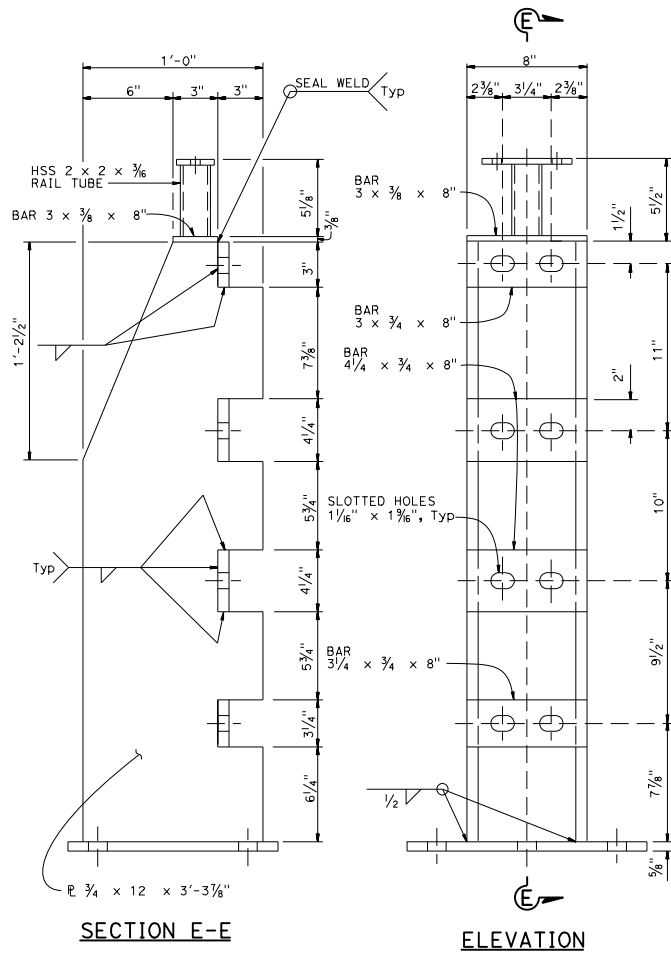

NOTES:

1. For approach and departure end details, see Revised Standard Plan RSP B11-73.
2. Post spacing and/or block length to be adjusted to fit bridge length or wingwall length.
3. All horizontal members are parallel to longitudinal profile grade of deck.
4. Posts are normal to profile grade of structure.
5. Posts are vertical to the transverse cross section.

STATE OF CALIFORNIA
DEPARTMENT OF TRANSPORTATION
CALIFORNIA ST-20S BRIDGE RAIL
(SHEET 2 OF 4)

NO SCALE

RSP B11-72 DATED JULY 15, 2016 SUPPLEMENTS THE STANDARD PLANS BOOK DATED 2015.

REVISED STANDARD PLAN RSP B11-72

2015 REVISED STANDARD PLAN RSP B11-72

DIST	COUNTY	ROUTE	POST MILES TOTAL PROJECT	SHEET TOTAL SHEETS

Gregory J. Koberg
 REGISTERED CIVIL ENGINEER
 No. C40814
 Exp. 3-31-17
 CIVIL
 STATE OF CALIFORNIA

July 15, 2016
 PLANS APPROVAL DATE
 THE STATE OF CALIFORNIA OR ITS OFFICERS OR AGENTS SHALL NOT BE RESPONSIBLE FOR THE ACCURACY OR COMPLETENESS OF SCANNED COPIES OF THIS PLAN SHEET.

TO ACCOMPANY PLANS DATED _____

NOTES:

1. Anchor bolts may be tack welded (shop or field) to anchorage.
2. Each rail length must be continuous over a minimum of two posts.
3. The Contractor must check that the tubular sleeve splices conform to the dimensions indicated to assure proper clearance.
4. Except for expansion splices, not more than one splice permitted per same side of post.

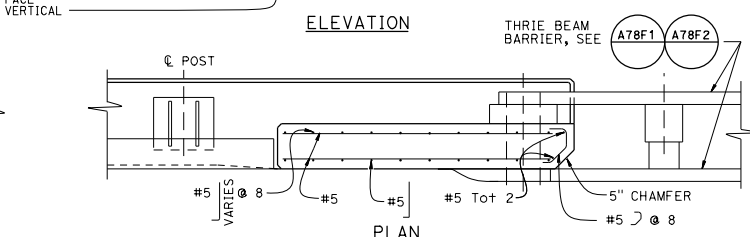
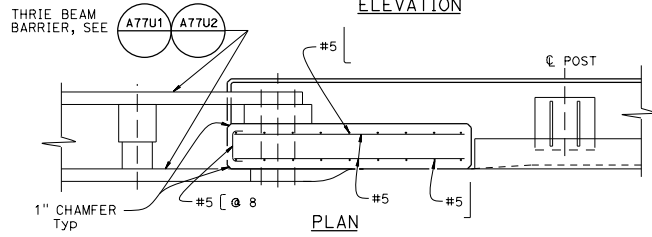
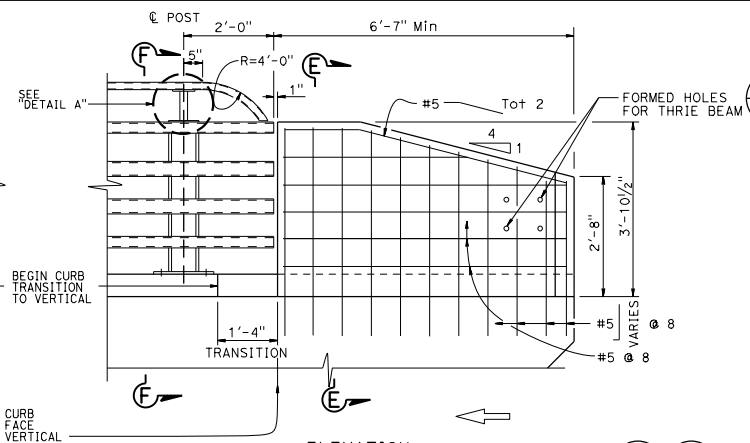
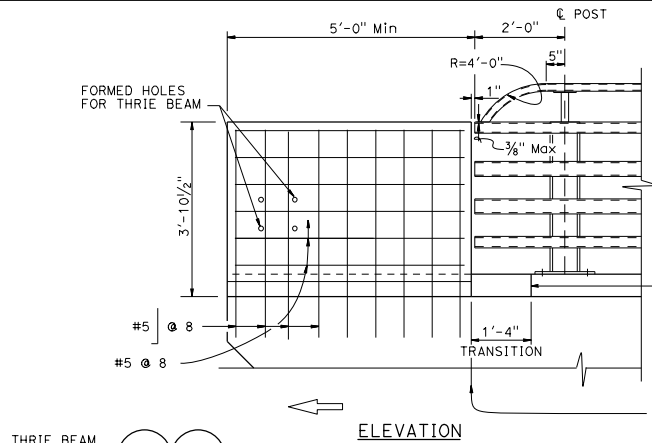

END BLOCK DETAIL

TRANSITION BLOCK DETAIL

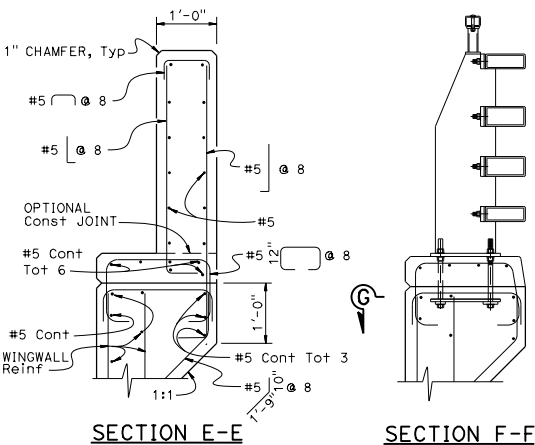

SECTION F-F

NOTE:
For details not shown, see "SECTION E-E"

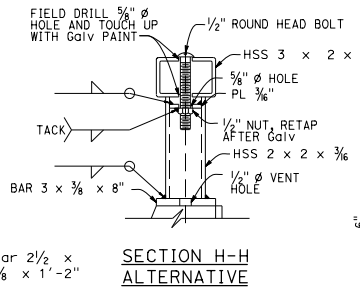
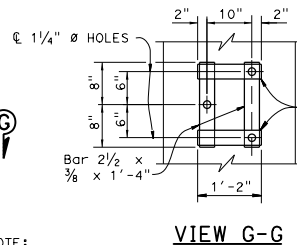

SECTION H-H ALTERNATIVE

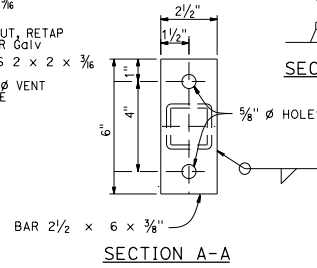

RAIL CONNECTION DETAILS

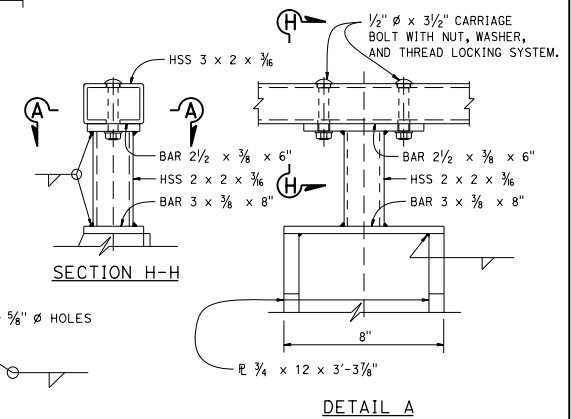

STATE OF CALIFORNIA
DEPARTMENT OF TRANSPORTATION
CALIFORNIA ST-20S BRIDGE RAIL
(SHEET 3 OF 4)

NO SCALE

RSP B11-73 DATED JULY 15, 2016 SUPPLEMENTS THE STANDARD PLANS BOOK DATED 2015.

REVISED STANDARD PLAN RSP B11-73

2015 REVISED STANDARD PLAN RSP B11-73

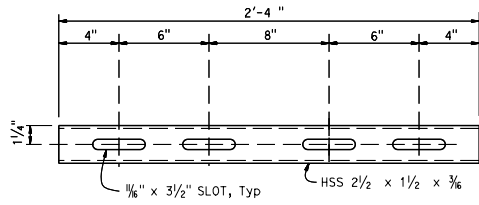

(FOR HSS 3 x 2 x 3/8 RAIL)
STANDARD SLEEVE DETAIL

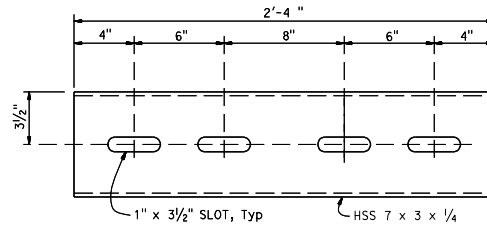

(FOR HSS 8 x 4 x 5/8 RAIL)
STANDARD SLEEVE DETAIL

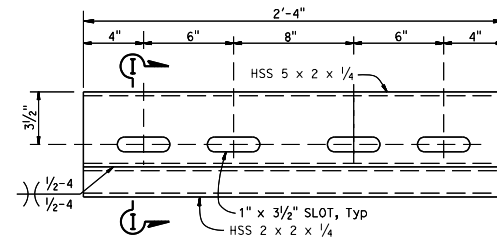

(FOR HSS 8 x 3 x 5/8 RAIL)
STANDARD SLEEVE DETAIL

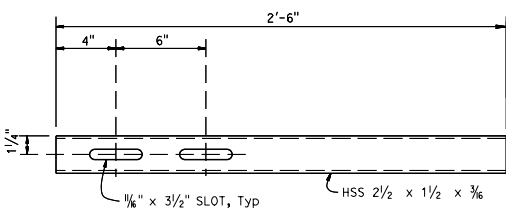

(FOR HSS 3 x 2 x 3/8 RAIL)
EXPANSION SLEEVE DETAIL

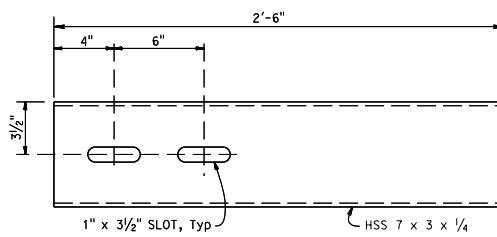

(FOR HSS 8 x 4 x 5/8 RAIL)
EXPANSION SLEEVE DETAIL

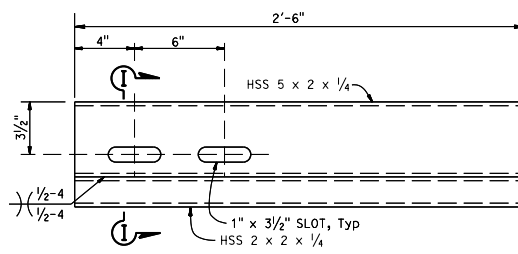

(FOR HSS 8 x 3 x 5/8 RAIL)
EXPANSION SLEEVE DETAIL

DIST	COUNTY	ROUTE	POST MILES TOTAL PROJECT	SHEET NO.	TOTAL SHEETS

Gregory J. Kaderobek
 REGISTERED CIVIL ENGINEER
 No. C40814
 Exp. 3-31-17
 CIVIL
 STATE OF CALIFORNIA

July 15, 2016
 PLANS APPROVAL DATE
 THE STATE OF CALIFORNIA OR ITS OFFICERS OR AGENTS SHALL NOT BE RESPONSIBLE FOR THE ACCURACY OR COMPLETENESS OF SCANNED COPIES OF THIS PLAN SHEET.

TO ACCOMPANY PLANS DATED _____

NOTES:

- HS bolts with nut and washers, snug tightened, and thread locking system.
- Use 1/2"Ø x 3 3/8" (HSS 8 x 2 x 3/8)
Use 3/4"Ø x 4 5/8" (HSS 8 x 3 x 5/8)
Use 3/4"Ø x 5 5/8" (HSS 8 x 4 x 5/8)

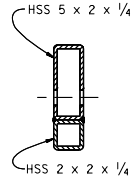

SECTION I-I

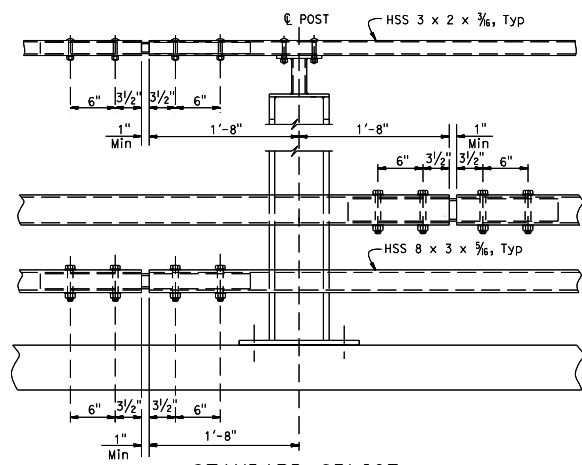

STANDARD SPLICE

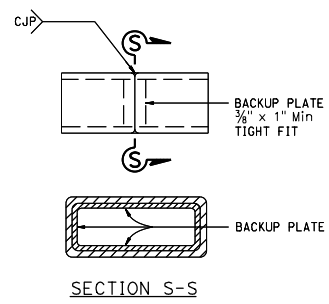

ALTERNATE TUBE WELDED SPLICE

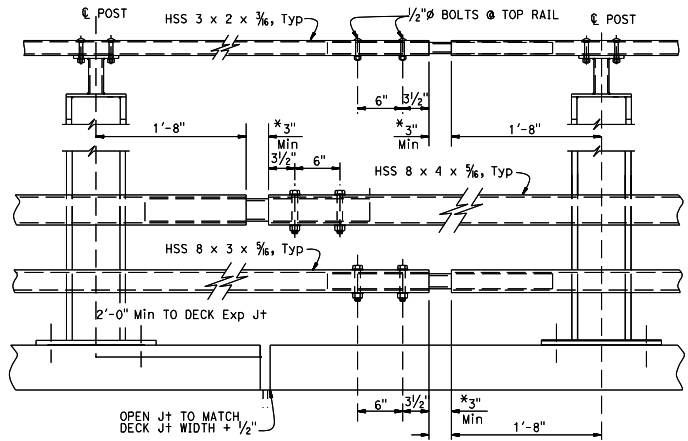

EXPANSION SPLICE

* MATCH DECK OR WALL JOINT

STATE OF CALIFORNIA
DEPARTMENT OF TRANSPORTATION

**CALIFORNIA ST-20S BRIDGE RAIL
(SHEET 4 OF 4)**

NO SCALE

RSP B11-74 DATED JULY 15, 2016 SUPPLEMENTS THE STANDARD PLANS BOOK DATED 2015.

REVISED STANDARD PLAN RSP B11-74

2015 REVISED STANDARD PLAN RSP B11-74

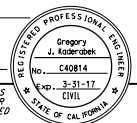
DIST	COUNTY	ROUTE	POST MILES TOTAL PROJECT	SHEET TOTAL SHEETS
				
July 15, 2016 PLANS APPROVAL DATE THE STATE OF CALIFORNIA OR ITS OFFICERS OR AGENTS SHALL NOT BE RESPONSIBLE FOR THE ACCURACY OR COMPLETENESS OF SCANNED COPIES OF THIS PLAN SHEET.				

TO ACCOMPANY PLANS DATED _____

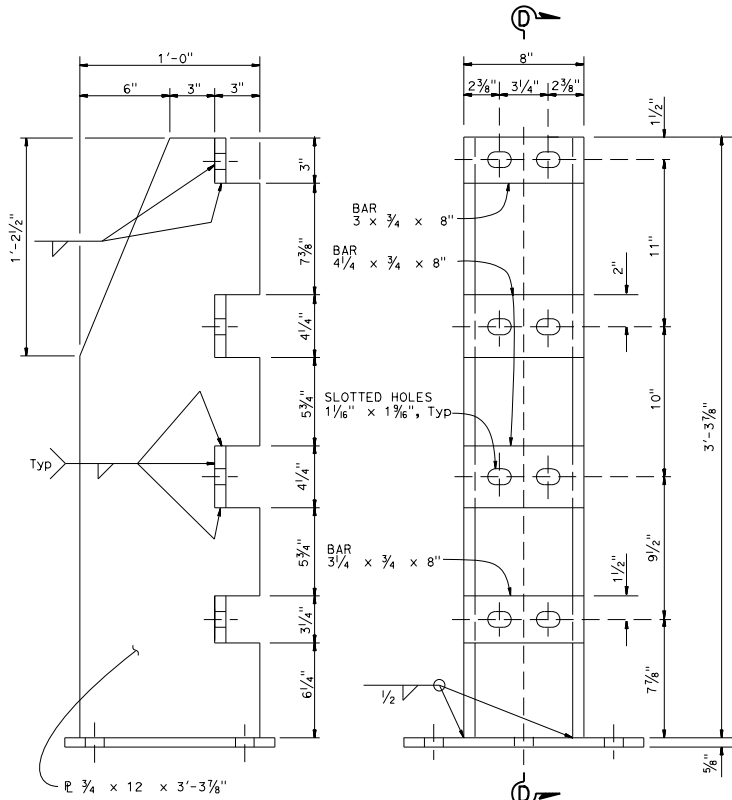

SECTION D-D

ELEVATION

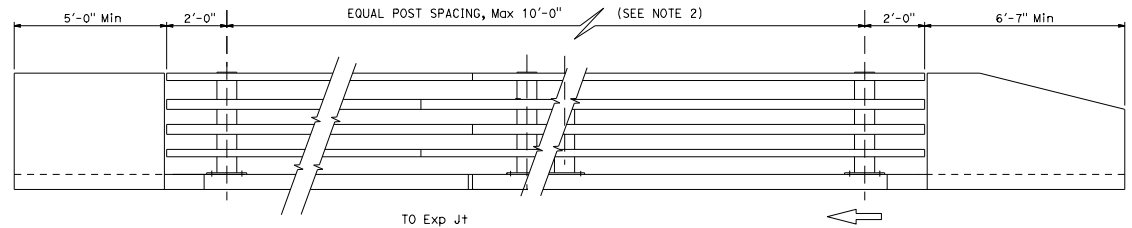

ELEVATION

NOTES:

1. For approach and departure end details, see Revised Standard Plan RSP B11-77.
2. Post spacing and/or block length to be adjusted to fit bridge length or wingwall length.
3. All horizontal members are parallel to longitudinal profile grade of deck.
4. Posts are normal to profile grade of structure.
5. Posts are vertical to the transverse cross section.

STATE OF CALIFORNIA
DEPARTMENT OF TRANSPORTATION
CALIFORNIA ST-70 BRIDGE RAIL
(SHEET 2 OF 4)

NO SCALE

RSP B11-76 DATED JULY 15, 2016 SUPPLEMENTS THE STANDARD PLANS BOOK DATED 2015.

REVISED STANDARD PLAN RSP B11-76

2015 REVISED STANDARD PLAN RSP B11-76

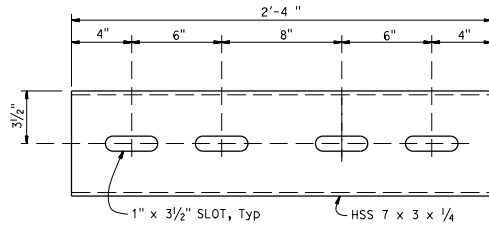

STANDARD SLEEVE DETAIL

(FOR HSS 8 x 4 x 5/16 RAIL)

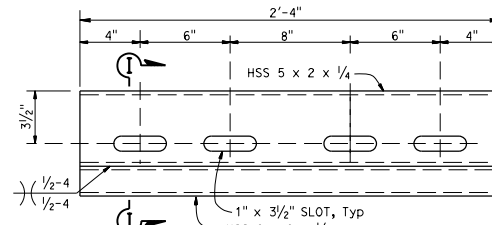

STANDARD SLEEVE DETAIL

(FOR HSS 8 x 3 x 5/16 RAIL)

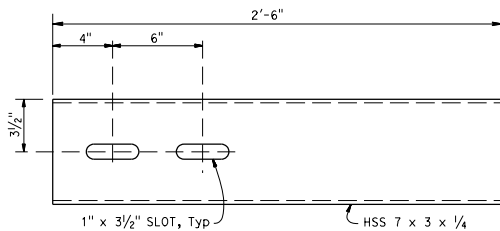

EXPANSION SLEEVE DETAIL

(FOR HSS 8 x 4 x 5/16 RAIL)

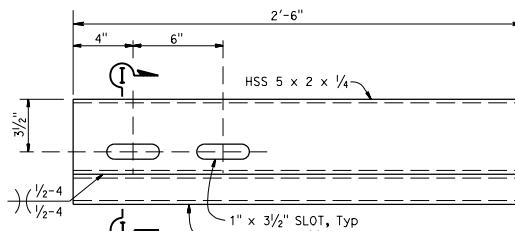

EXPANSION SLEEVE DETAIL

(FOR HSS 8 x 3 x 5/16 RAIL)

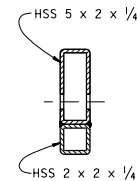

SECTION I-I

DIST	COUNTY	ROUTE	POST MILES TOTAL PROJECT	SHEET NO.	TOTAL SHEETS

Gregory J. Kadzabek
 REGISTERED CIVIL ENGINEER
 No. C40814
 July 15, 2016
 PLANS APPROVAL DATE
 THE STATE OF CALIFORNIA OR ITS OFFICERS OR AGENTS SHALL NOT BE RESPONSIBLE FOR THE ACCURACY OR COMPLETENESS OF SCANNED COPIES OF THIS PLAN SHEET.

TO ACCOMPANY PLANS DATED _____

NOTES:

1. HS bolts with nut and washers, snug tightened, and thread locking system.
2. Use 3/4"Ø x 4 5/16" (HSS 8 x 3 x 5/16)
Use 3/4"Ø x 5 5/16" (HSS 8 x 4 x 5/16)

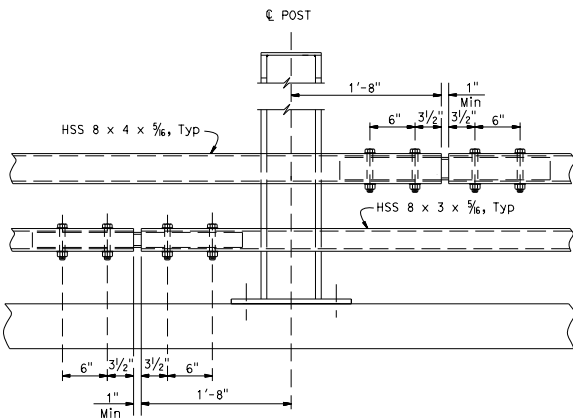

STANDARD SPLICE

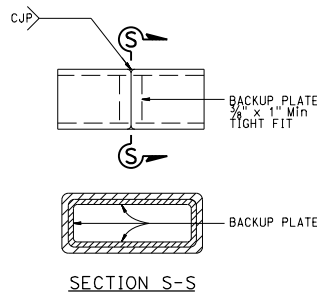

ALTERNATE TUBE WELDED SPLICE

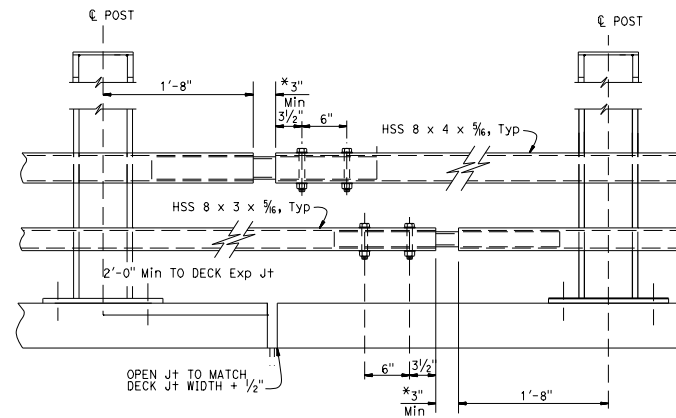

EXPANSION SPLICE

* MATCH DECK OR WALL JOINT

STATE OF CALIFORNIA
DEPARTMENT OF TRANSPORTATION

**CALIFORNIA ST-70 BRIDGE RAIL
(SHEET 4 OF 4)**

NO SCALE

RSP B11-78 DATED JULY 15, 2016 SUPPLEMENTS THE STANDARD PLANS BOOK DATED 2015.

REVISED STANDARD PLAN RSP B11-78

2015 REVISED STANDARD PLAN RSP B11-78

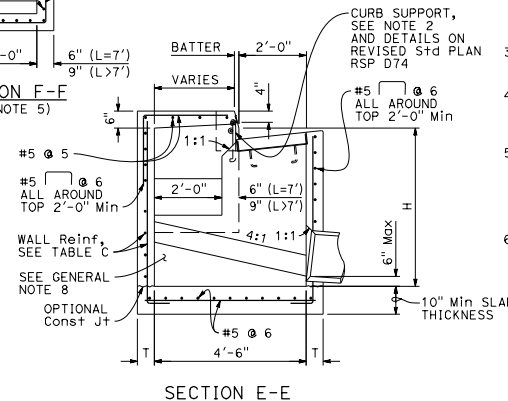
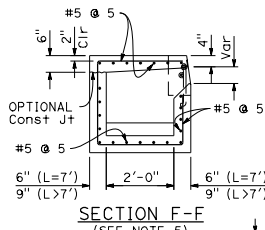
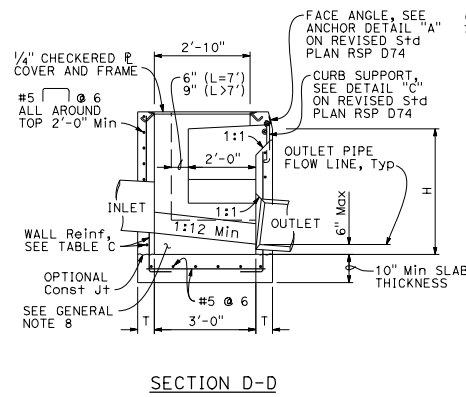
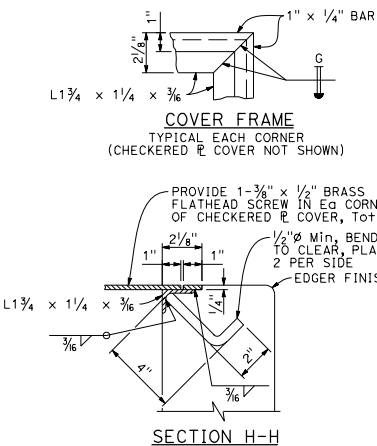
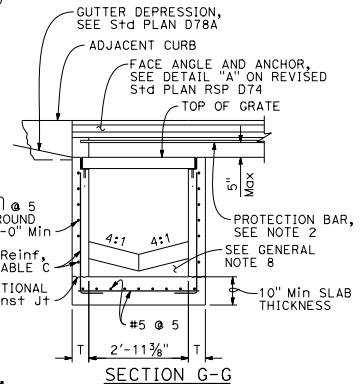
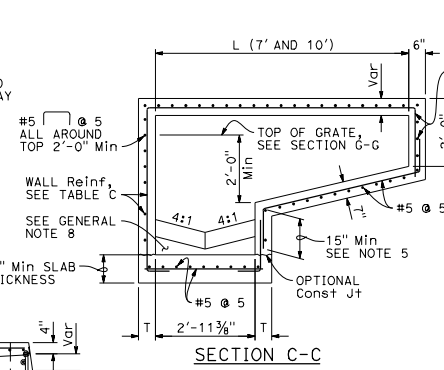
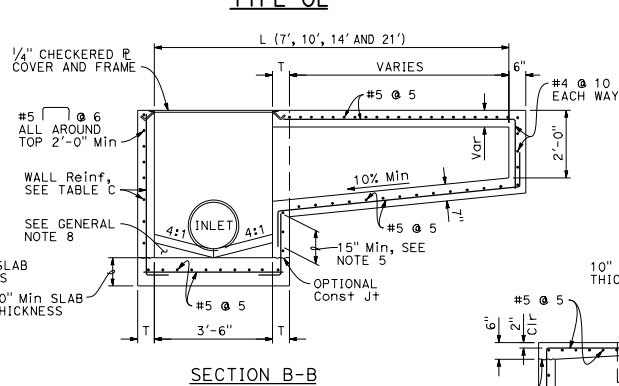
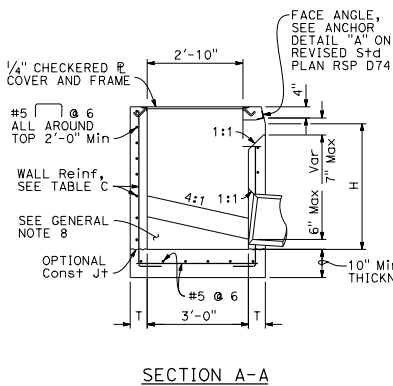
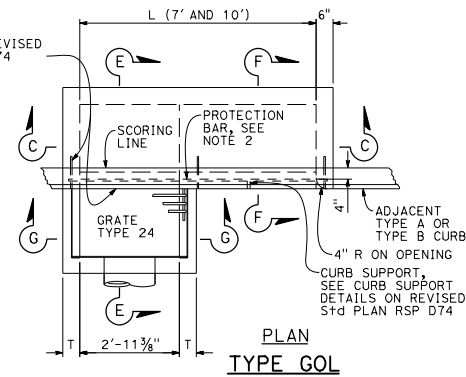
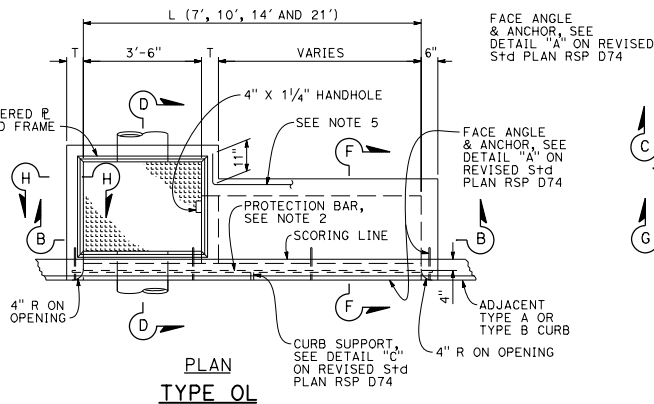
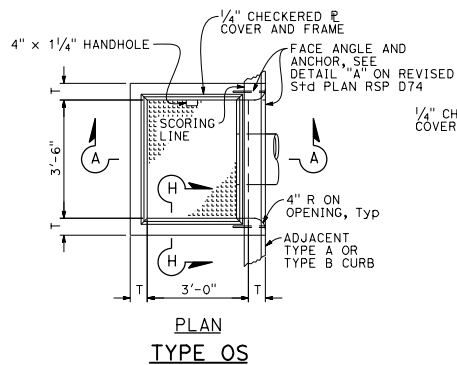

- NOTES:**
1. See Revised Standard Plan RSP D72F for General Notes and additional details. See Revised Standard Plan RSP D72G for tables, wall thickness "T" and quantities.
 2. Where shown on the project plans, place a 3/4 inch plain round protection bar horizontally across the length of the opening and bend back 4" into the inlet wall on each side.
 3. Complete joint penetration butt welds may be substituted for the fillet welds on all anchors.
 4. Standard square, hexagon, round or equivalent headed anchors may be substituted for the right angle hooks on the anchors shown in this plan.
 5. Extend all horizontal bars from inlet extensions into adjacent concrete elements of main inlet box a minimum of 15". Where shown, bend horizontal bars into box. If necessary rotate bars to maintain 2" clear coverage.
 6. Height of curb opening will vary with the type of curb and the depth of the local depression.

STATE OF CALIFORNIA
DEPARTMENT OF TRANSPORTATION
CIP DRAINAGE INLETS
TYPES OS, OL AND GOL
NO SCALE

RSP D72A DATED JULY 15, 2016 SUPPLEMENTS THE STANDARD PLANS BOOK DATED 2015.
REVISED STANDARD PLAN RSP D72A

DIST	COUNTY	ROUTE	POST MILES TOTAL PROJECT	SHEET TOTAL SHEETS

REGISTERED CIVIL ENGINEER
July 15, 2016
PLANS APPROVAL DATE
THE STATE OF CALIFORNIA OR ITS OFFICERS OR AGENTS SHALL NOT BE RESPONSIBLE FOR THE ACCURACY OR COMPLETENESS OF SCANNED COPIES OF THIS PLAN SHEET.

2015 REVISED STANDARD PLAN RSP D72A

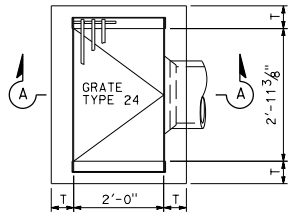

PLAN
TYPE G1

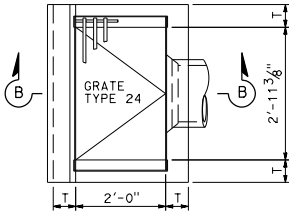

PLAN
TYPE G3

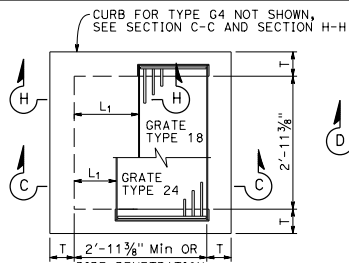

PLAN
STANDARD
TYPE G2 OR G4

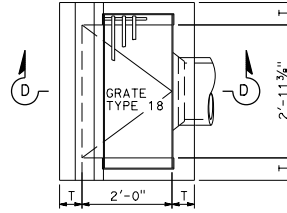

PLAN
TYPE G5

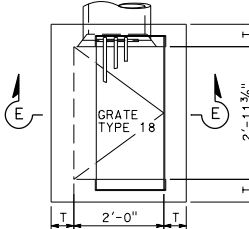

PLAN
TYPE G6

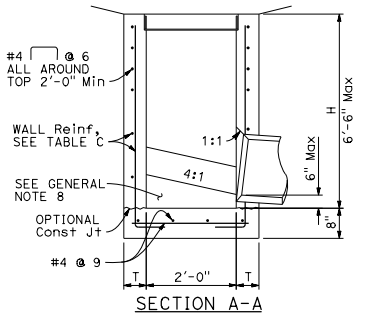

SECTION A-A

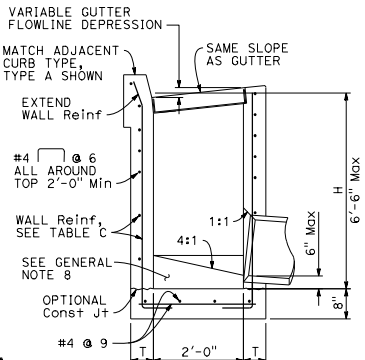

SECTION B-B

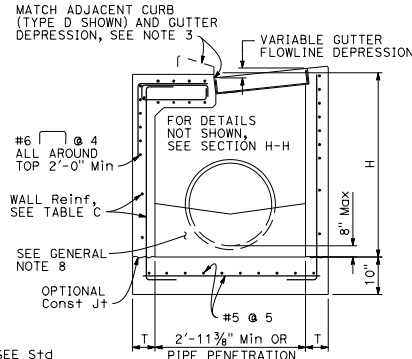

SECTION C-C

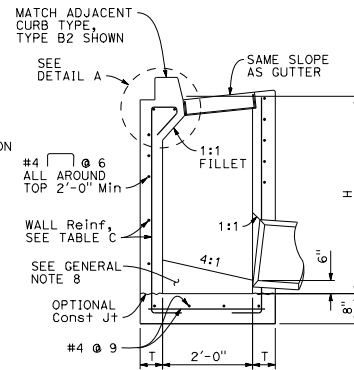

SECTION D-D

TABLE 1

L ₁ OR L ₂ > 2'-10"	T
	12"

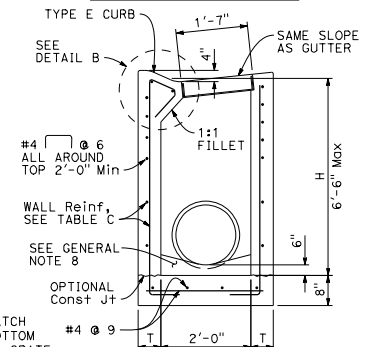

SECTION E-E

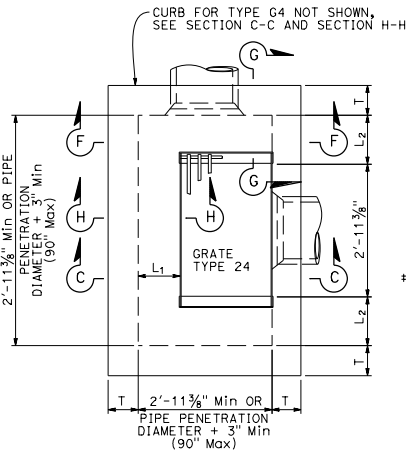

PLAN
EXPANDED
TYPE G2 OR G4

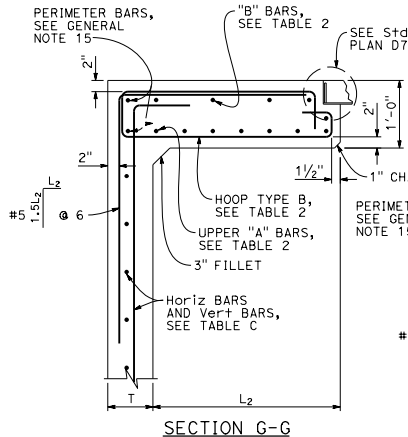

SECTION G-G

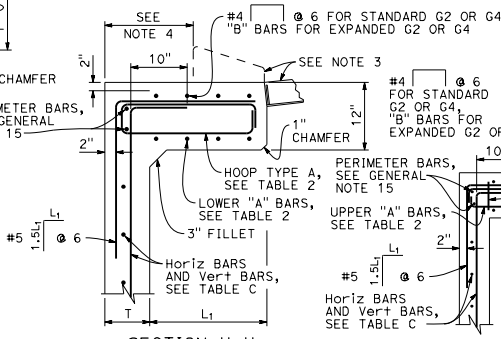

SECTION H-H

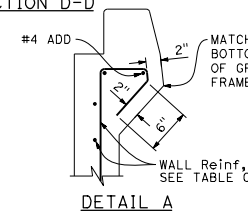

DETAIL A

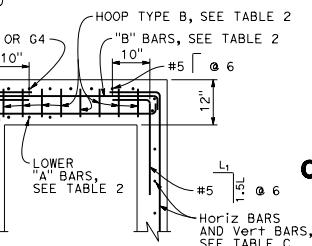

SECTION F-F

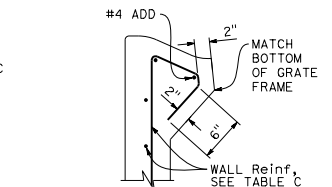

DETAIL B

STATE OF CALIFORNIA
DEPARTMENT OF TRANSPORTATION
**CIP DRAINAGE INLETS
TYPES G1, G2, G3,
G4, G5 AND G6**
NO SCALE

RSP D72B DATED JULY 21, 2017 SUPERSEDES RSP D72B
DATED JULY 15, 2016 THAT SUPPLEMENTS THE STANDARD PLANS BOOK DATED 2015.
REVISED STANDARD PLAN RSP D72B

DIST	COUNTY	ROUTE	POST MILES TOTAL PROJECT	SHEET TOTAL SHEETS

REGISTERED CIVIL ENGINEER
July 21, 2017
PLANS APPROVAL DATE
THE STATE OF CALIFORNIA OR ITS OFFICERS OR AGENTS SHALL NOT BE RESPONSIBLE FOR THE ACCURACY OR COMPLETENESS OF SCANNED COPIES OF THIS PLAN SHEET.

REGISTERED PROFESSIONAL ENGINEER
Carl W. Dugan
No. C59876
Exp. 6-30-18
CIVIL
STATE OF CALIFORNIA

- TO ACCOMPANY PLANS DATED _____
- NOTES:
- For notes and Table 2, See Revised Standard Plan RSP D72C.
 - For L₁ or L₂ greater than 2'-10", see Table 1 for wall thickness dimension and see Table C in Revised Standard Plan RSP D72G for reinforcement. Otherwise, see Table C in Revised Standard Plan RSP D72G for wall thickness and reinforcement.

2015 REVISED STANDARD PLAN RSP D72B

DIST	COUNTY	ROUTE	POST MILES TOTAL PROJECT	SHEET NO.	TOTAL SHEETS

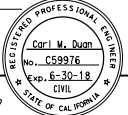

 REGISTERED CIVIL ENGINEER

July 21, 2017
 PLANS APPROVAL DATE

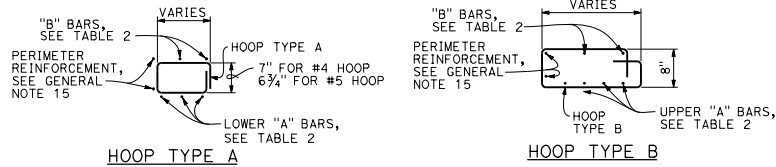

THE STATE OF CALIFORNIA OR ITS OFFICERS OR AGENTS SHALL NOT BE RESPONSIBLE FOR THE ACCURACY OR COMPLETENESS OF SCANNED COPIES OF THIS PLAN SHEET.

TO ACCOMPANY PLANS DATED _____



NOTES:

1. See Revised Standard Plan RSP D72F for General Notes and additional details. See Revised Standard Plan RSP D72G for tables and quantities.
2. Type G4 inlet can use Grate Type 18 or 24. Type G2 inlet uses Grate Type 24.
3. Type G4 inlet details are similar to Type G2 inlet details, except for the addition of a curb and sloped grate to match the adjacent curb and gutter depression.
4. Dimension will vary with different grates, curb types, box width and wall thickness.

	W/ CURB	W/O CURB
"A" BARS	#4 @ 5 (2 BARS Min)	#5 @ 5 (3 BARS Min)
"B" BARS	#4 @ 10 (2 BARS Min)	#4 @ 12 (2 BARS Min)
HOOPS ("A" & "B")	#4 @ 5	#5 @ 5

ROTATE "A" AND "B" BARS SO HOOKED ENDS WILL MAINTAIN 2" CLEAR COVERAGE.

STATE OF CALIFORNIA
DEPARTMENT OF TRANSPORTATION
**CIP DRAINAGE INLETS
TYPES G1, G2, G3,
G4, G5 AND G6**

NO SCALE

RSP D72C DATED JULY 21, 2017 SUPERSEDES RSP D72C DATED JULY 15, 2016 THAT SUPPLEMENTS THE STANDARD PLANS BOOK DATED 2015.

REVISED STANDARD PLAN RSP D72C

2015 REVISED STANDARD PLAN RSP D72C

DIST	COUNTY	ROUTE	POST MILES TOTAL PROJECT	SHEET TOTAL SHEETS



 REGISTERED CIVIL ENGINEER
 July 15, 2016
 PLANS APPROVAL DATE
 THE STATE OF CALIFORNIA OR ITS OFFICERS OR AGENTS SHALL NOT BE RESPONSIBLE FOR THE ACCURACY OR COMPLETENESS OF SCANNED COPIES OF THIS PLAN SHEET.

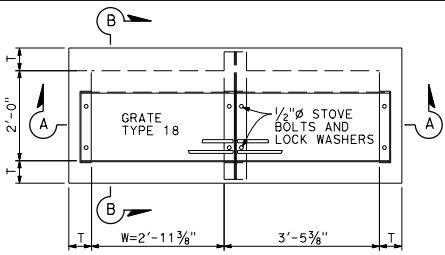

PLAN
TYPE GT1

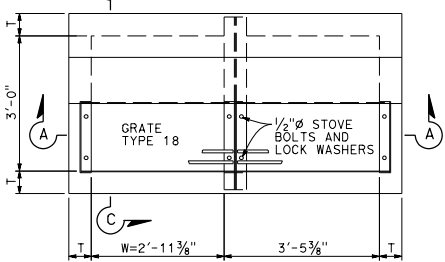
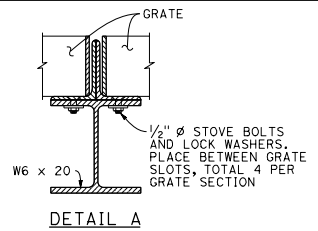
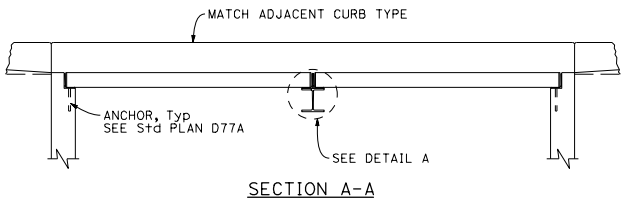

PLAN
TYPE GT2

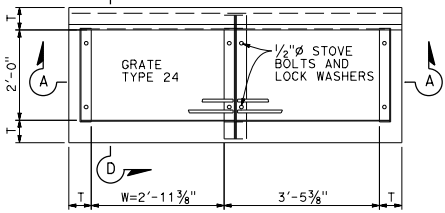
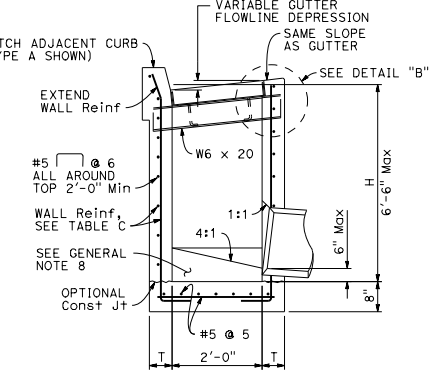
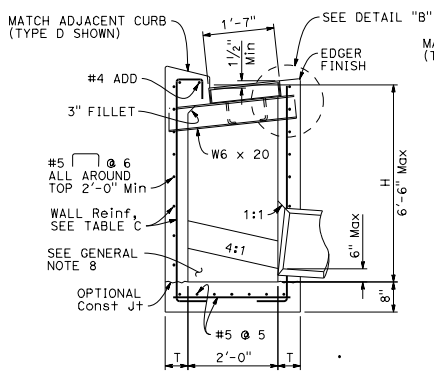

PLAN
TYPE GT3

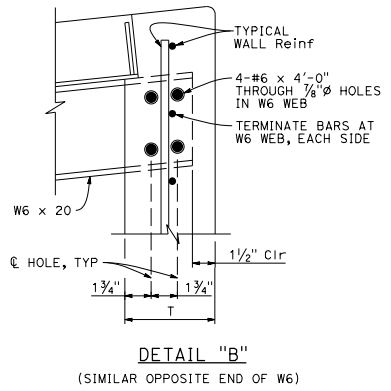
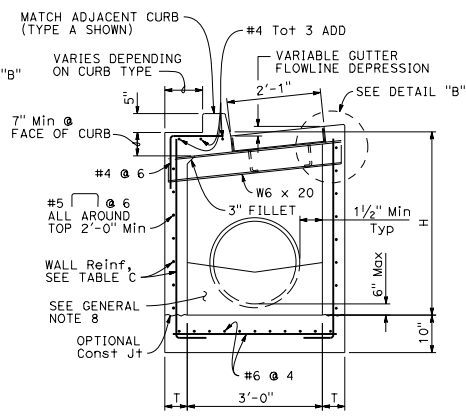
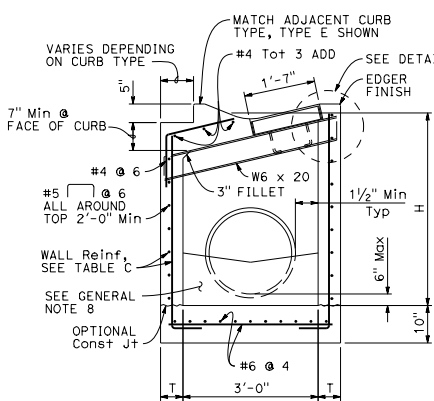

NOTES:

1. See Revised Standard Plan RSP D72F for General Notes and additional details. See Revised Standard Plan RSP D72G for tables, wall thickness "T" and quantities.
2. W=2'-11 3/8" for one grate. Add 3'-5 3/8" for additional grates in tandem.
3. Complete joint penetration butt welds may be substituted for the fillet welds on all anchors.
4. Standard square, hexagon, round or equivalent headed anchors may be substituted for the right angle hooks on the anchors shown on this plan.

STATE OF CALIFORNIA
DEPARTMENT OF TRANSPORTATION
**CIP DRAINAGE INLETS
TYPES GT1, GT2,
GT3 AND GT4**

NO SCALE

RSP D72D DATED JULY 15, 2016 SUPPLEMENTS THE STANDARD PLANS BOOK DATED 2015.

REVISED STANDARD PLAN RSP D72D

2015 REVISED STANDARD PLAN RSP D72D

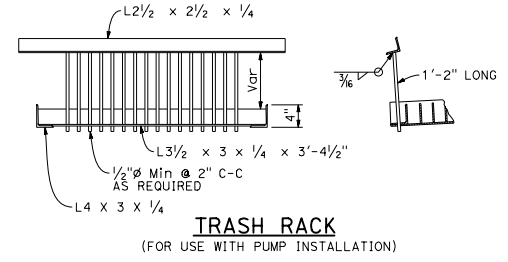
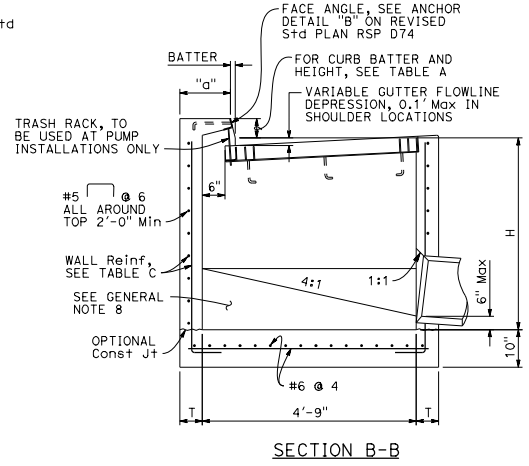
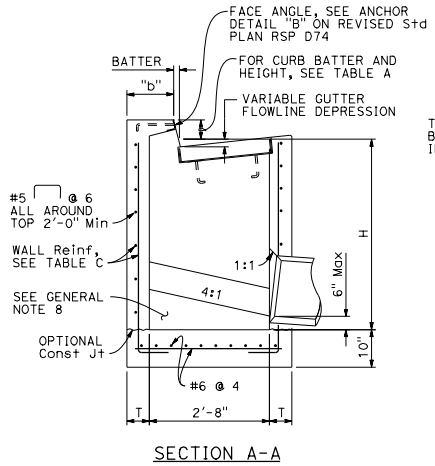
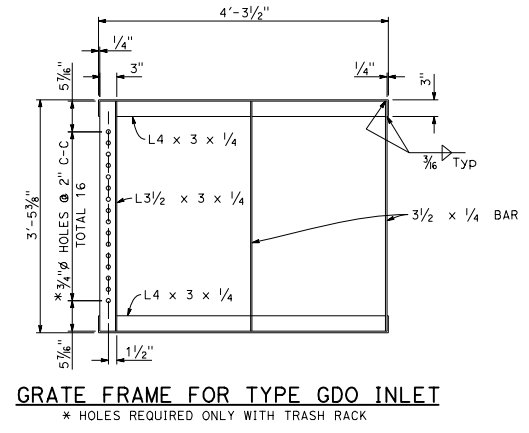
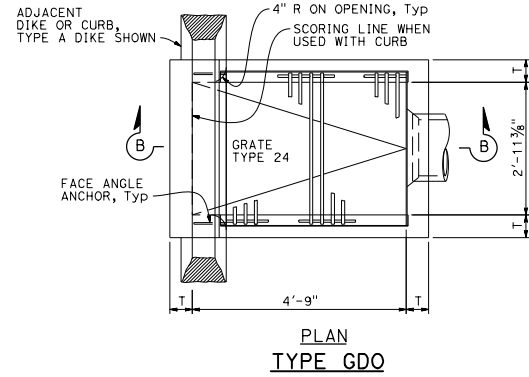
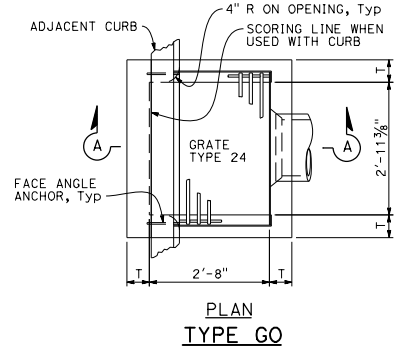

TABLE A

CURB TYPE	NORMAL CURB HEIGHT	CURB BATTER	"a" DIMENSION	"b" DIMENSION
A1-6	6"	1 1/2"	T+7 1/2"	T+6 1/2"
A1-8	8"	2"	T+7"	T+6"
B1-6	6"	4"	T+5"	T+4"
TYPE A DIKE	6"	3"	T+6"	T+5"

Height of curb opening will vary with the type of curb and the depth of the local depression.

D18+	COUNTY	ROUTE	POST MILES TOTAL PROJECT	SHEET TOTAL SHEETS

REGISTERED CIVIL ENGINEER
Carl M. Duong
No. C59976
Exp. 6-30-18
CIVIL
STATE OF CALIFORNIA

July 15, 2016
PLANS APPROVAL DATE

THE STATE OF CALIFORNIA OR ITS OFFICERS OR AGENTS SHALL NOT BE RESPONSIBLE FOR THE ACCURACY OR COMPLETENESS OF SCANNED COPIES OF THIS PLAN SHEET.

TO ACCOMPANY PLANS DATED _____

NOTES:

- See Revised Standard Plan RSP D72F for General Notes and additional details. See Revised Standard Plan RSP D72G for tables, wall thickness "T" and quantities.
- Where shown on the project plans, place a 3/4" plain round protection bar horizontally across the length of the opening and bend back 4" into the inlet wall on each side.
- Complete joint penetration butt welds may be substituted for the fillet welds on all anchors.
- Standard square, hexagon, round or equivalent headed anchors may be substituted for the right angle hooks on the anchors shown on this plan.

STATE OF CALIFORNIA
DEPARTMENT OF TRANSPORTATION
**CIP DRAINAGE INLETS
TYPES GO AND GDO**
NO SCALE

RSP D72E DATED JULY 15, 2016 SUPPLEMENTS THE STANDARD PLANS BOOK DATED 2015.
REVISED STANDARD PLAN RSP D72E

2015 REVISED STANDARD PLAN RSP D72E

GENERAL NOTES:

- "H" is measured from top of bottom slab to the normal gutter grade line undepressed at the curb face.
- For "T" wall thickness and reinforcement, see Table C on Revised Standard Plan RSP D72G.
- Wall reinforcement must be placed in the center of the wall thickness with horizontal bars placed on the exterior face. Bottom slab concrete cover must be 3" clear on the interior face unless otherwise noted. Top slab concrete cover must be 2" clear on the exterior face unless otherwise noted. Reinforcement spacing is in inches unless otherwise noted.
- Steps - None required where "H" is less than 2'-6". Where "H" is 2'-6" or more, install steps with lowest rung 1'-0" above the floor and highest rung not more than 6" below bottom of lid. The distance between steps must not exceed 1'-0" and be uniform throughout the length of the wall. Place steps in the wall without an opening. Steps inserts may be substituted for the bar steps. Step inserts must comply with State Industrial Safety Requirements. See Revised Standard Plan RSP D74 for step details.
- Pipe(s) can be placed in any wall. Adjacent to each side of the opening, place additional reinforcement equivalent to half the interrupted main reinforcement. For larger pipes greater than or equal to 42" diameter, also add 4 diagonal bars, 1 bar each side. Bars must be the same size as the larger of the main vertical or horizontal bars. Extend bars one development length past the intersection with the adjacent diagonal bar, or where bars intersect mid thickness of adjacent wall bottom or top of non-continuous wall, bend ends as required into same plane.
- Set inlet so that grate bars are parallel to direction of principal surface flow.
- Curb section must match adjacent curb.
- Except for inlets used as junction boxes, basin floors must have wood trowel finish and a minimum slope of 4:1, unless otherwise noted, from all directions toward outlet pipe by casting grout fill on top of the bottom slab. The additional volume to achieve the 4:1 slope may also be achieved by casting the bottom slab and fill as a composite concrete element.
- See Standard Plans D77A and D77B for grate and frame details and weights of miscellaneous iron and steel.
- See Standard Plans D78A and D78B for gutter depression details.
- See Standard Plan A87A and Revised Standard Plan RSP A87B for curb and dike details.
- Details shown apply to metal, concrete and plastic pipe(s).
- The Contractor may use WWR instead of bar reinforcement. The ratio of bar reinforcement to WWR shall be based on the yield strength ratio.
- Cast-in-place (CIP) inlets to be formed around all pipes/stubs intersecting the inlet, and concrete poured in one continuous operation.
- Perimeter reinforcement must not be smaller than main bars and #4 and serves as a rigid frame to position and attach the required structural reinforcement and may be tack welded at outer corners when using ASTM A706 weldable bars.

DESIGN NOTES:

- Design Specifications: AASHTO LRFD Bridge Design Specifications, 6th edition with 2012 Interims and Errata and CA Amendments.
- Live Load (AASHTO LRFD 3.6.1.2):
HL-93, consists of design truck or tandem, and design lane load.
Dynamic Load Allowance, $IM = 33\%$
Multiple Presence Factor, $m = 1.0$
Design lane load was excluded in Top Slab design.
A wheel load of 8 kips without impact factor was used for top slabs that are above a curb.
- Earth Load:
Vertical pressure = 140 pcf
Lateral pressure:
= 100 pcf for walls with flat embankment, 1.5:1 Max
= 140 pcf for walls with slope embankment, 1.5:1 Max
- Downdrag: $\phi = 34^\circ$ and $\gamma_E = 120$ pcf.
- Buoyancy: $\gamma_w = 62.4$ pcf to finished grade
- Reinforced Concrete: $f'_c = 3.6$ ksi, $f_y = 60.0$ ksi.
- Soil pressures shown are factored per AASHTO LRFD and include self-weight, live load and downdrag.

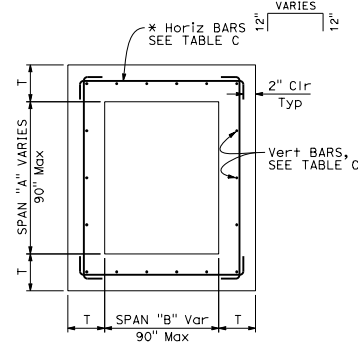

TYPICAL INLET PLAN

* ALTERNATIVE HORIZONTAL BARS



DIST	COUNTY	ROUTE	POST MILES TOTAL PROJECT	SHEET TOTAL SHEETS

REGISTERED CIVIL ENGINEER
 Carl M. Duong
 No. C59976
 STATE OF CALIFORNIA
 CIVIL
 Exp. 6-30-18

July 15, 2016
 PLANS APPROVAL DATE
 THE STATE OF CALIFORNIA OR ITS OFFICERS OR AGENTS SHALL NOT BE RESPONSIBLE FOR THE ACCURACY OR COMPLETENESS OF SCANNED COPIES OF THIS PLAN SHEET.

TO ACCOMPANY PLANS DATED _____

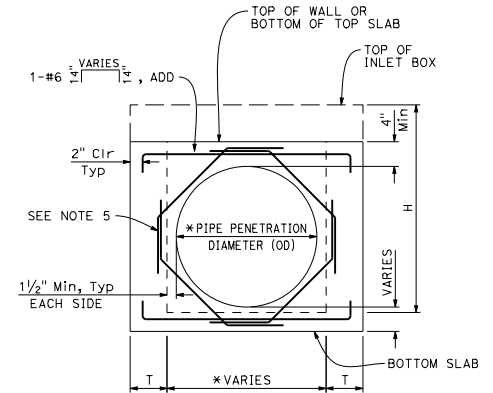

**TYPICAL WALL
W/ PIPE OPENING**

* SEE "SKEWED PIPE PLAN"

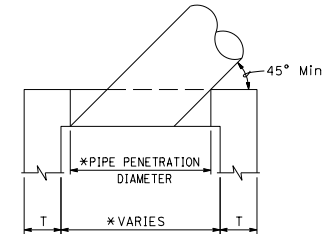

SKEWED PIPE PLAN

* ADJUST PIPE PENETRATION AND BOX WIDTH FOR SKEWED PIPES.

STATE OF CALIFORNIA
DEPARTMENT OF TRANSPORTATION

CIP DRAINAGE INLET NOTES

NO SCALE

RSP D72F DATED JULY 15, 2016 SUPPLEMENTS THE STANDARD PLANS BOOK DATED 2015.

REVISED STANDARD PLAN RSP D72F

2015 REVISED STANDARD PLAN RSP D72F

TABLE A - CONCRETE QUANTITIES

TYPE	H=3'-0" TO 8'-0"		H=8'-1" TO 20'-0"	
	H=3'-0" (CY)	ADDITIONAL CONCRETE PER FOOT (CY)	H=8'-1" (CY)	ADDITIONAL CONCRETE PER FOOT (CY)
G1	0.95	0.220	SEE NOTE 2	SEE NOTE 2
G2*	2.00	0.411	5.11	0.525
G3	1.03	0.220	SEE NOTE 2	SEE NOTE 2
G4 (TYPE 18)*	2.02	0.411	5.14	0.525
G4 (TYPE 24)*	1.99	0.411	5.10	0.525
G5	1.02	0.220	SEE NOTE 2	SEE NOTE 2
G6	1.04	0.220	SEE NOTE 2	SEE NOTE 2
OS	1.53	0.278	5.08	0.504
OL7	2.06	0.278	6.17	0.566
OL10	2.85	0.278	6.85	0.566
OL14	3.81	0.278	7.78	0.566
OL21	5.71	0.278	9.62	0.566
GOL7	2.48	0.313	6.89	0.630
GOL10	3.41	0.313	7.85	0.630
GT1	1.72	0.248	SEE NOTE 2	SEE NOTE 2
GT2	2.93	0.530	7.73	0.762
GT3	1.74	0.348	SEE NOTE 2	SEE NOTE 2
GT4	2.83	0.530	7.62	0.762
GO	1.26	0.245	4.90	0.506
GDO	1.74	0.322	6.33	0.647

* Quantities are based on the minimum interior dimensions.

TABLE B - REINFORCEMENT QUANTITIES

TYPE	H=3'-0" TO 8'-0"		H=8'-1" TO 20'-0"	
	H=3'-0" (LB)	ADDITIONAL REINFORCEMENT PER FOOT (LB)	H=8'-1" (LB)	ADDITIONAL REINFORCEMENT PER FOOT (LB)
G1	118	22.20	SEE NOTE 2	SEE NOTE 2
G2*	729	86.48	1794	171.79
G3	118	22.20	SEE NOTE 2	SEE NOTE 2
G4 (TYPE 18)*	647	86.48	1675	171.79
G4 (TYPE 24)*	647	86.48	1675	171.79
G5	118	22.20	SEE NOTE 2	SEE NOTE 2
G6	118	22.20	SEE NOTE 2	SEE NOTE 2
OS	245	49.88	1057	120.77
OL7	458	50.53	1324	126.75
OL10	729	50.53	1595	126.75
OL14	982	50.53	1849	126.75
OL21	1453	50.53	2320	126.75
GOL7	644	83.57	1969	148.79
GOL10	883	83.57	2208	148.79
GT1	486	96.91	SEE NOTE 2	SEE NOTE 2
GT2	1040	117.08	2543	233.37
GT3	486	96.91	SEE NOTE 2	SEE NOTE 2
GT4	1001	117.08	2556	237.88
GO	308	32.44	1013	96.56
GDO	519	57.09	1654	165.66

* Quantities are based on the minimum interior dimensions.

TABLE D

INLET	CURB USED IN QUANTITIES
G1	-
G2	-
G3	A1-6
G4 (Type 18)	A1-6
G4 (Type 24)	A1-6
G5	B1-4
G6	1/2E
OS	-
OL7	-
OL10	-
OL14	-
OL21	-
GOL7	-
GOL10	-
GT1	D-6
GT2	E
GT3	A2-8
GT4	A2-8
GO	-
GDO	-

TABLE C - WALL REINFORCEMENT

TYPE	H≤8 (T=6",UON)		8<H≤20 (T=11",UON)	
	HORIZ	VERTICAL	HORIZ	VERTICAL
OS	#4 @ 8	#4 @ 6	#5 @ 6	#6 @ 4.5
OL	#4 @ 6	#4 @ 6	#5 @ 6	#6 @ 4.5
GOL	#5 @ 6	#5 @ 8	#6 @ 5	#6 @ 4.5
G1 (H≤6-6")	#3 @ 6	#3 @ 6	-	-
G2 (H≤6-6")	T=9" #5 @ 5	#5 @ 5	T=11" #6 @ 4	#6 @ 4.5
G3 (H≤6-6")	#3 @ 6	#3 @ 6	-	-
G4 (H≤6-6")	T=9" #5 @ 5	#5 @ 5	T=11" #6 @ 4	#6 @ 4.5
G5 (H≤6-6")	#3 @ 6	#3 @ 6	-	-
G6 (H≤6-6")	#3 @ 6	#3 @ 6	-	-
GT1 (H≤6-6")	#5 @ 6	#5 @ 6	-	-
GT2 (H≤6-6")	T=8" #5 @ 6	#5 @ 6	#6 @ 4	#6 @ 4.5
GT3 (H≤6-6")	#5 @ 6	#5 @ 6	-	-
GT4 (H≤6-6")	T=8" #5 @ 6	#5 @ 6	#6 @ 4	#6 @ 4.5
GO	#4 @ 9	#4 @ 6	#4 @ 6	#6 @ 4.5
GDO	#4 @ 6	#4 @ 6	#5 @ 4	#6 @ 4.5

TABLE E

TYPE	SOIL PRESSURE BELOW BASE SLAB (ksf)	
	H=8'-0"	8'-0" < H ≤ 20'-0"
OS	2.93	5.56
OL*	2.93	5.56
GOL*	2.50	5.06
G1	3.67	-
G2	2.99	5.91
G3	3.67	-
G4	2.99	5.91
G5	3.67	-
G6	3.67	-
GT1	3.66	-
GT2	3.91	6.07
GT3	3.86	-
GT4	3.91	6.07
GO	3.42	6.11
GDO	2.52	6.95

* Main Box

DIST	COUNTY	ROUTE	POST MILES TOTAL PROJECT	SHEET TOTAL SHEETS



 REGISTERED CIVIL ENGINEER
 July 15, 2016
 PLANS APPROVAL DATE
 THE STATE OF CALIFORNIA OR ITS OFFICERS OR AGENTS SHALL NOT BE RESPONSIBLE FOR THE ACCURACY OR COMPLETENESS OF SCANNED COPIES OF THIS PLAN SHEET.

TO ACCOMPANY PLANS DATED _____

NOTES:

1. No deduction or adjustment was made to the quantities of concrete and reinforcement for pipe openings, floor alternatives or curb type.
2. Maximum allowable height is 6'-6".
3. Quantities are approximate and for design purposes only.
4. Design is based on envelope of level and sloped ground.

STATE OF CALIFORNIA
DEPARTMENT OF TRANSPORTATION

CIP DRAINAGE INLET TABLES

NO SCALE

RSP D726 DATED JULY 15, 2016 SUPPLEMENTS THE STANDARD PLANS BOOK DATED 2015.

REVISED STANDARD PLAN RSP D72G

2015 REVISED STANDARD PLAN RSP D72G

DIST	COUNTY	ROUTE	POST MILES TOTAL PROJECT	SHEET TOTAL SHEETS

REGISTERED CIVIL ENGINEER
Carli M. Duong
 No. C59976
 Exp. 6-30-18
 CIVIL
 STATE OF CALIFORNIA

July 15, 2016
 PLANS APPROVAL DATE
 THE STATE OF CALIFORNIA OR ITS OFFICERS OR AGENTS SHALL NOT BE RESPONSIBLE FOR THE ACCURACY OR COMPLETENESS OF SCANNED COPIES OF THIS PLAN SHEET.

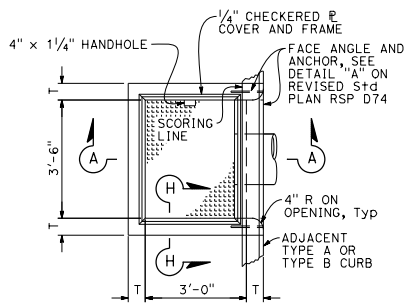

PLAN TYPE OS

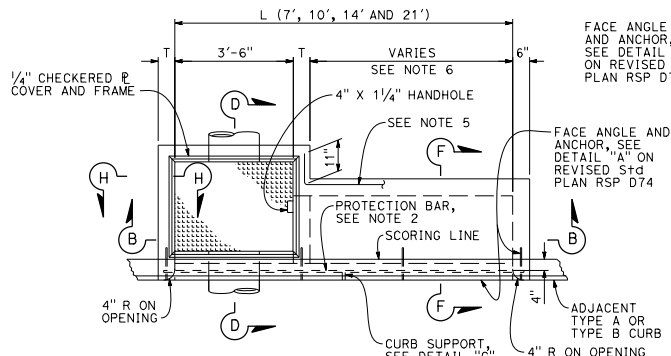

PLAN TYPE OL

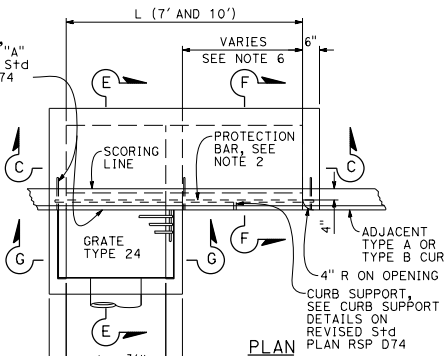

PLAN TYPE GOL

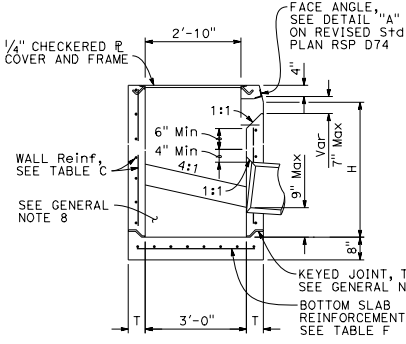

SECTION A-A

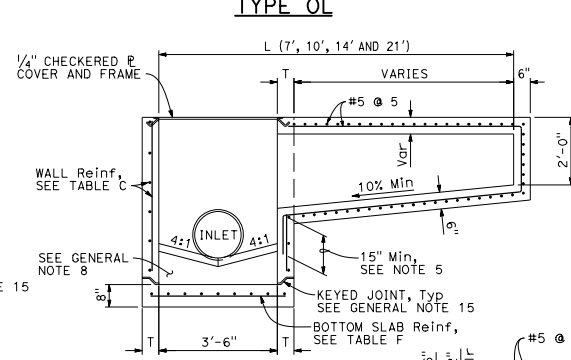

SECTION B-B

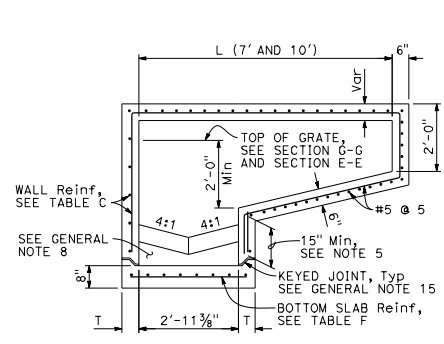

SECTION C-C

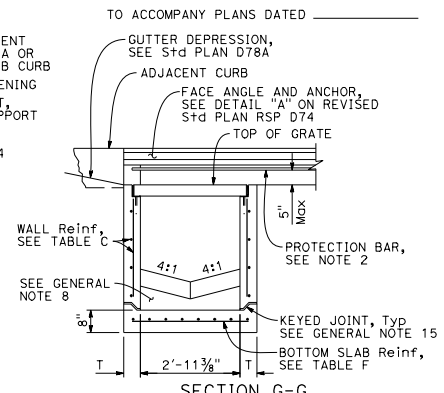

SECTION G-G

NOTES:

1. See Revised Standard Plan RSP D73F for General Notes and additional details. See Revised Standard Plan RSP D73G for tables, wall thickness "T" and quantities.
2. When shown on the project plans, place a 3/4" dia plain round protection bar horizontally across the length of the opening and bend back 4" into the inlet wall on each side.
3. Complete joint penetration butt welds may be substituted for the fillet welds on all anchors.
4. Standard square, hexagon, round or equivalent headed anchors may be substituted for the right angle hooks on the anchors shown on this plan.
5. Extend all horizontal bars from inlet extensions into adjacent concrete elements of main inlet box a minimum of 15". Where shown, bend horizontal bars into box. If necessary rotate bars to maintain 2" clear coverage.
6. Height of curb opening will vary with the type of curb and the depth of the local depression.

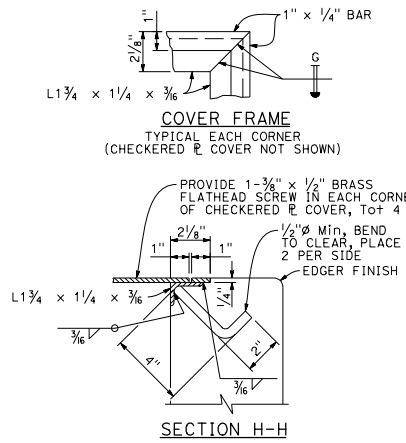

SECTION H-H

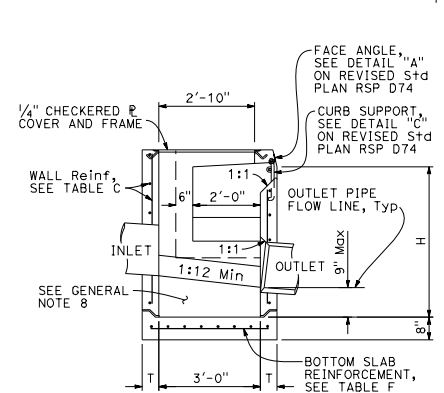

SECTION D-D

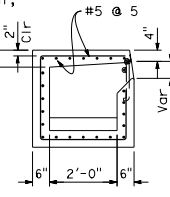

SECTION F-F

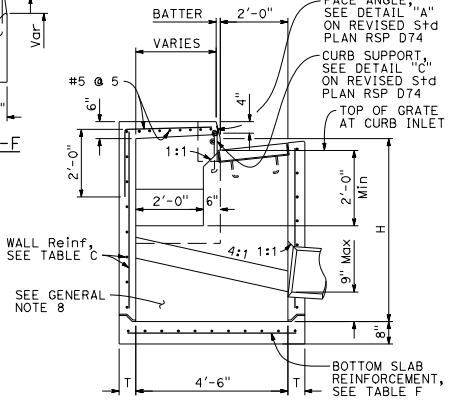

SECTION E-E

STATE OF CALIFORNIA
 DEPARTMENT OF TRANSPORTATION
PRECAST DRAINAGE INLETS
TYPES OS, OL AND GOL
 NO SCALE

RSP D73A DATED JULY 15, 2016 SUPERSEDES STANDARD PLAN D73A
 DATED OCTOBER 30, 2015 - PAGE 174 OF THE STANDARD PLANS BOOK DATED 2015.
REVISED STANDARD PLAN RSP D73A

2015 REVISED STANDARD PLAN RSP D73A

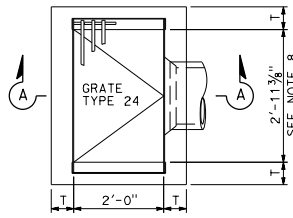

PLAN
TYPE G1

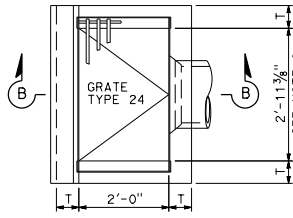

PLAN
TYPE G3

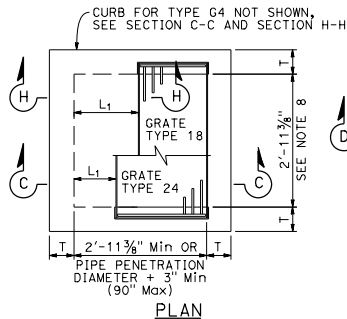

PLAN
STANDARD TYPE G2 OR G4

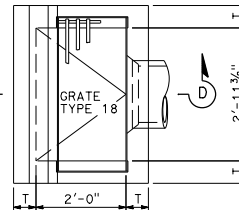

PLAN
TYPE G5

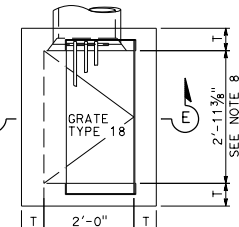

PLAN
TYPE G6

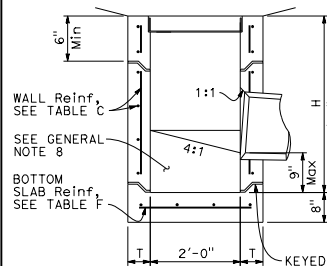

SECTION A-A

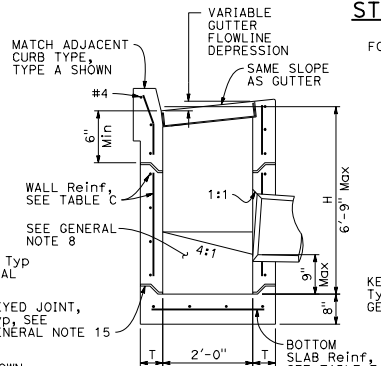

SECTION B-B

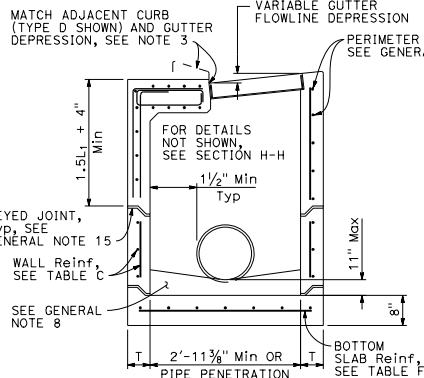

SECTION C-C

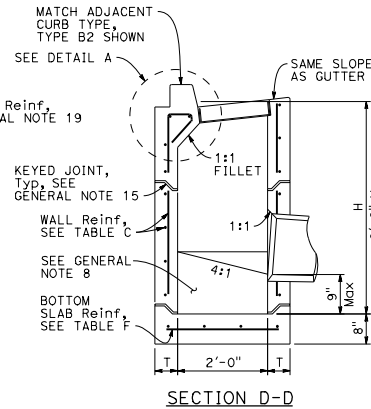

SECTION D-D

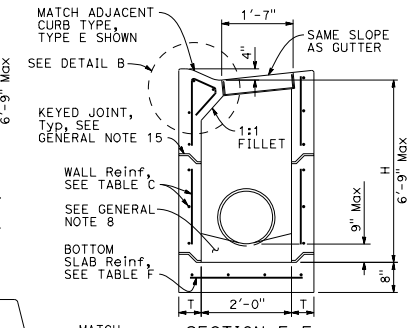

SECTION E-E

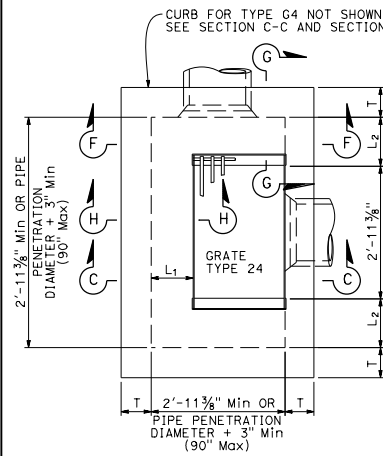

PLAN
EXPANDED
TYPE G2 OR G4

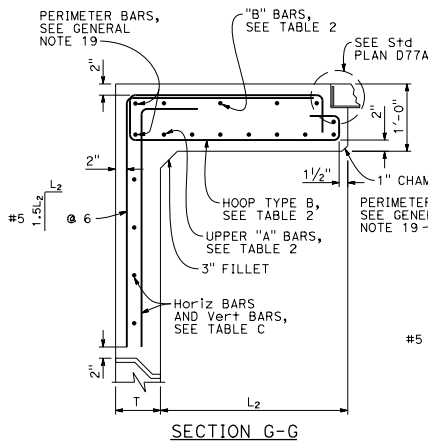

SECTION G-G

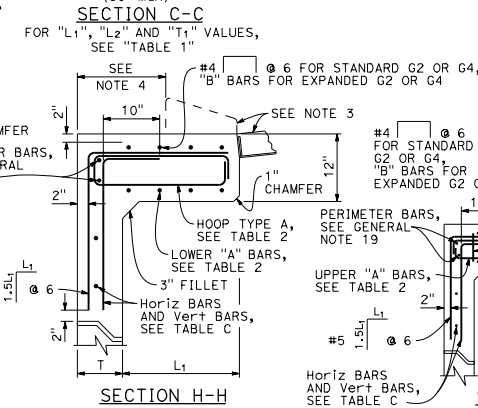

SECTION H-H

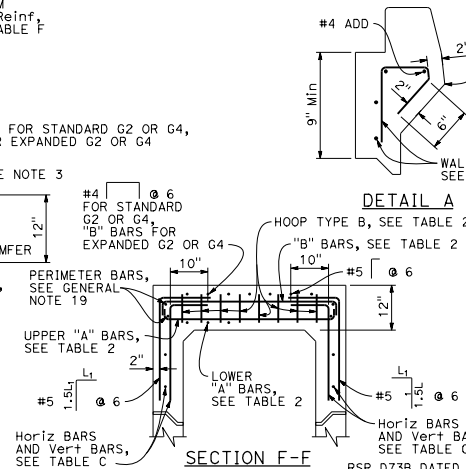

SECTION F-F

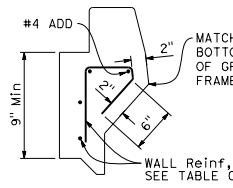

DETAIL A

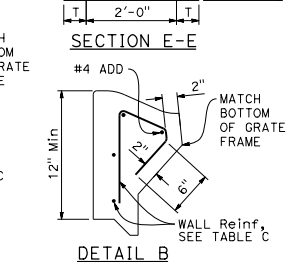

DETAIL B

(INTEGRAL TOP ALTERNATIVE)
FOR "L" AND "T" VALUES, SEE TABLE 1

MATCH ADJACENT CURB TYPE, TYPE B2 SHOWN
SAME SLOPE AS GUTTER

TABLE 1	
L1 OR L2 > 2'-10"	12"

NOTES:
1. For notes and Table 2, See Revised Standard Plan RSP D73C.
2. For L1 or L2 greater than 2'-10", see Table 1 for wall thickness dimension and see Table C in Revised Standard Plan RSP D73G for reinforcement. Otherwise, see Table C in Revised Standard Plan RSP D73G for wall thickness and reinforcement.

STATE OF CALIFORNIA
DEPARTMENT OF TRANSPORTATION
**PRECAST
DRAINAGE INLETS
TYPES G1, G2, G3,
G4, G5 AND G6**
NO SCALE

REVISED STANDARD PLAN RSP D73B

2015 REVISED STANDARD PLAN RSP D73B

DIST	COUNTY	ROUTE	POST MILES TOTAL PROJECT	SHEET TOTAL SHEETS

REGISTERED CIVIL ENGINEER
 July 21, 2017
 PLANS APPROVAL DATE
 THE STATE OF CALIFORNIA OR ITS OFFICERS OR AGENTS SHALL NOT BE RESPONSIBLE FOR THE ACCURACY OR COMPLETENESS OF SCANNED COPIES OF THIS PLAN SHEET.

REGISTERED PROFESSIONAL ENGINEER
 Carl M. Dugan
 No. C59976
 Exp. 6-30-18
 CIVIL
 STATE OF CALIFORNIA

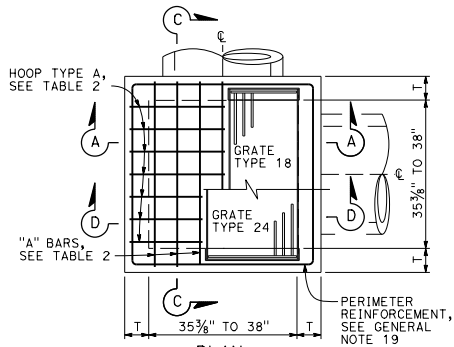

STANDARD TYPE G2 OR G4

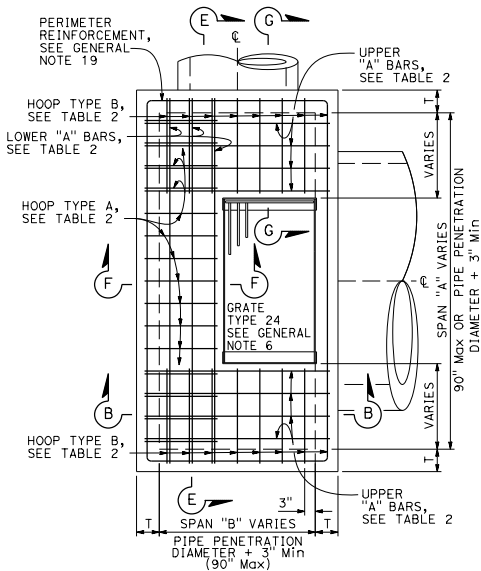

EXPANDED TYPE G2 OR G4 (TOP REBAR NOT SHOWN)

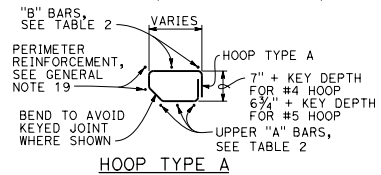

HOOP TYPE A

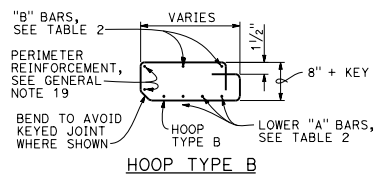

HOOP TYPE B

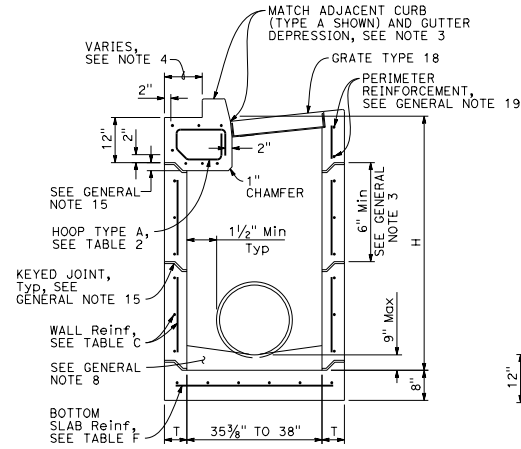

SECTION A-A (WITH G4 TOP)

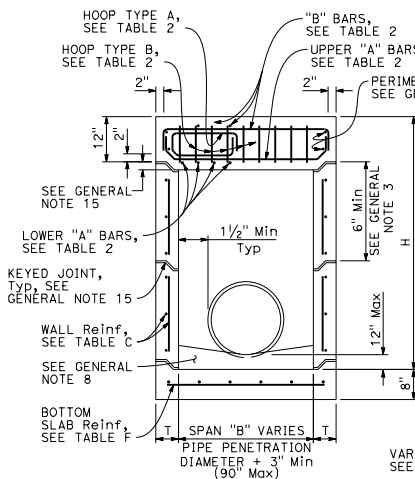

SECTION B-B (WITH G2 TOP)

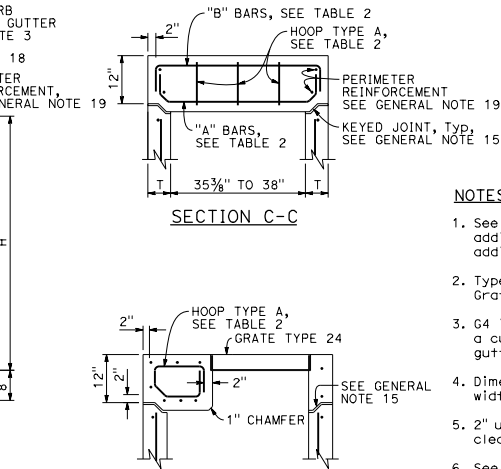

SECTION C-C

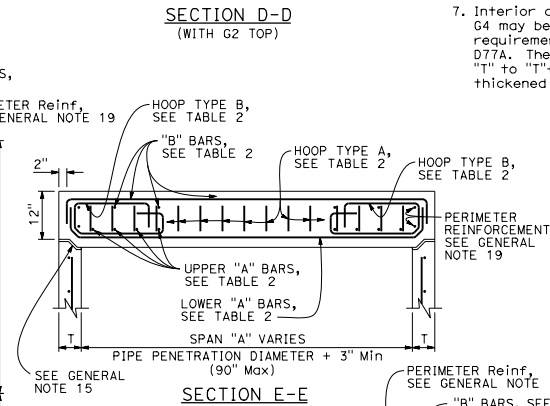

SECTION D-D (WITH G2 TOP)

SECTION E-E

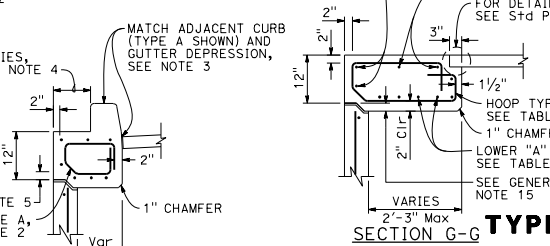

SECTION F-F (WITH G4 TOP)

SECTION G-G

NOTES:

- See Revised Standard Plan RSP D73F for General Notes and additional details. See Revised Standard Plan RSP D73G for additional tables, wall thickness "T" and quantities.
- Type G4 inlet can use Grate Type 18 or 24. Type G2 inlet uses Grate Type 24.
- G4 inlet details are the same as the G2 with the addition of a curb and sloped grate that matches the adjacent curb and gutter depression.
- Dimension will vary with different grates, curb types, box width and wall thickness.
- 2" unless inlet is expanded in the Span "A" direction, then clearance is 2" plus the diameter of the lower "A" bar.
- See Revised Standard Plan RSP D73B for integral top slab alternative.
- Interior dimension of lower sections of inlet for Types G2 and G4 may be 3'-0" provided top section conforms to the requirements for frame and grate types on Standard Plan D77A. The wall thickness of top sections may transition from "T" to "T"+1/8" to meet this requirement. Minimum height of thickened wall shall = "T".

TO ACCOMPANY PLANS DATED _____

TABLE 2 - TOP SLAB REINFORCEMENT		
16 BAR DIAMETERS	"A" & "B" BARS	BEND TO AVOID KEYED JOINT WHERE SHOWN
	VARIES	
	W/ CURB	W/O CURB
"A" BARS	#4 @ 5 (2 BARS Min)	#5 @ 5 (3 BARS Min)
"B" BARS	#4 @ 10 (2 BARS Min)	#4 @ 10 (2 BARS Min)
HOOPS ("A" & "B")	#4 @ 5	#5 @ 5

ROTATE "A" AND "B" BARS SO HOOKED ENDS WILL MAINTAIN 2" CLEAR COVERAGE.

STATE OF CALIFORNIA
DEPARTMENT OF TRANSPORTATION

PRECAST DRAINAGE INLETS TYPES G1, G2, G3, G4, G5 AND G6
NO SCALE

RSP D73C DATED JULY 21, 2017 SUPERSEDES RSP D73C DATED JULY 15, 2016 THAT SUPPLEMENTS THE STANDARD PLANS BOOK DATED 2015.

REVISED STANDARD PLAN RSP D73C

2015 REVISED STANDARD PLAN RSP D73C

DIST	COUNTY	ROUTE	POST MILES TOTAL PROJECT	SHEET TOTAL NO. SHEETS



 REGISTERED CIVIL ENGINEER
 July 15, 2016
 PLANS APPROVAL DATE
 THE STATE OF CALIFORNIA OR ITS OFFICERS OR AGENTS SHALL NOT BE RESPONSIBLE FOR THE ACCURACY OR COMPLETENESS OF SCANNED COPIES OF THIS PLAN SHEET.

TO ACCOMPANY PLANS DATED _____

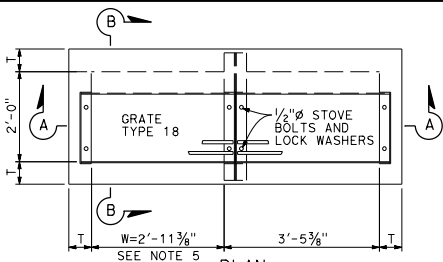

PLAN
TYPE GT1

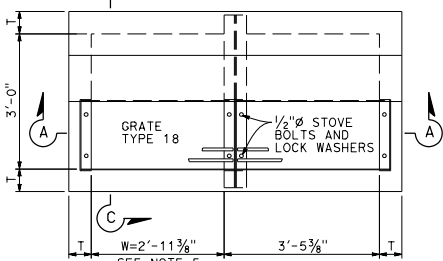

PLAN
TYPE GT2

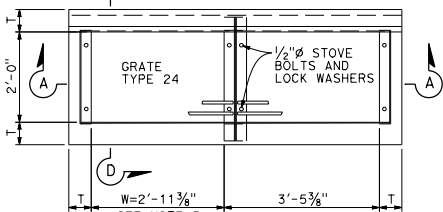

PLAN
TYPE GT3

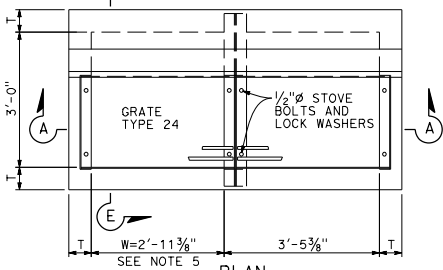

PLAN
TYPE GT4

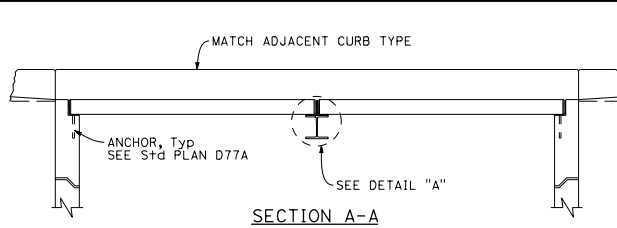

SECTION A-A

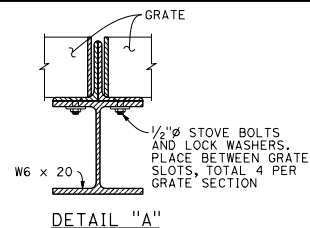

DETAIL "A"

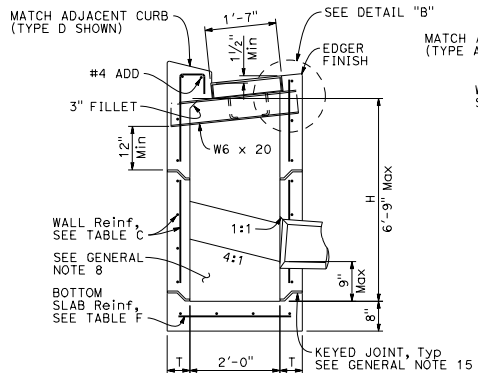

SECTION B-B

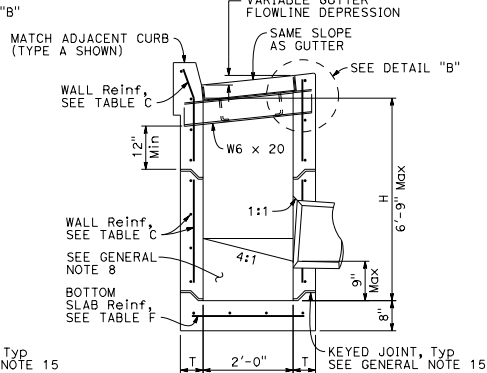

SECTION D-D

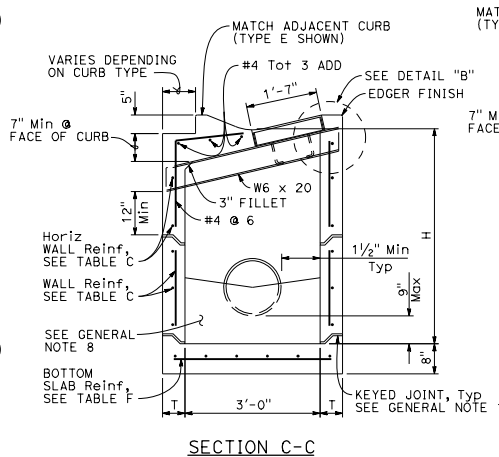

SECTION C-C

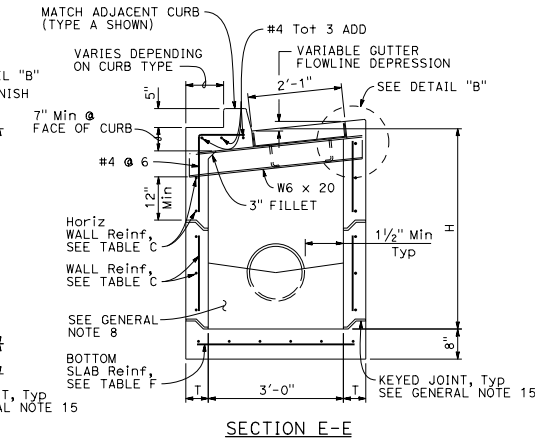

SECTION E-E

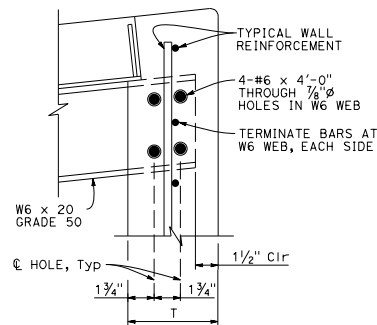

DETAIL "B"
(SIMILAR OPPOSITE END OF W6)

STATE OF CALIFORNIA
DEPARTMENT OF TRANSPORTATION
**PRECAST
DRAINAGE INLETS
TYPES GT1, GT2,
GT3 AND GT4**

NO SCALE

RSP D73D DATED JULY 15, 2016 SUPPLEMENTS THE STANDARD PLANS BOOK DATED 2015.

REVISED STANDARD PLAN RSP D73D

2015 REVISED STANDARD PLAN RSP D73D

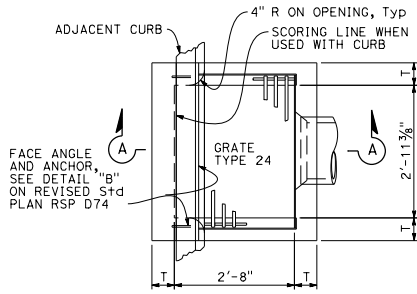

PLAN
TYPE GO

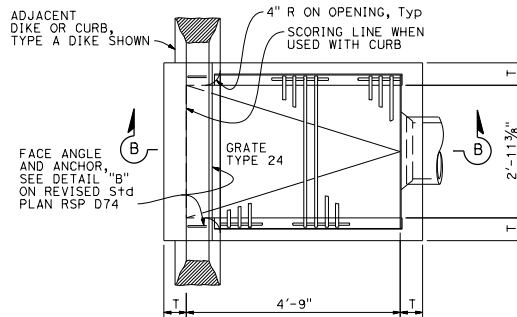

PLAN
TYPE GDO

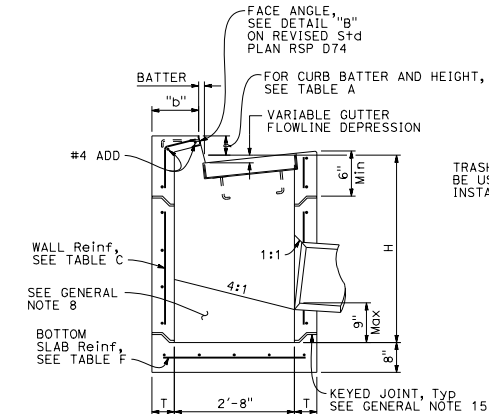

SECTION A-A

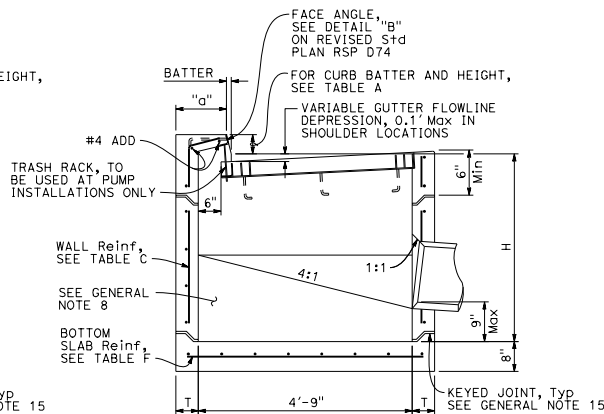

SECTION B-B

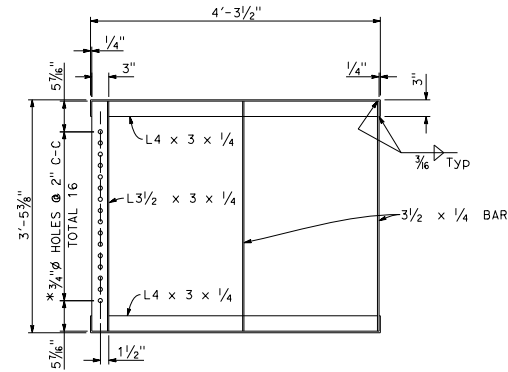

GRATE FRAME FOR TYPE GDO INLET

* HOLES REQUIRED ONLY WITH TRASH RACK

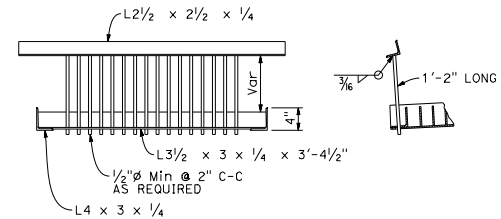

TRASH RACK
FOR USE WITH PUMP INSTALLATION

NOTES:

1. See Revised Standard Plan RSP D73F for General Notes and additional details. See Revised Standard Plan RSP D73G for tables, wall thickness "T" and quantities.
2. Where shown on the project plans, place a 3/4" x plain round protection bar horizontally across the length of the opening and bend back 4" into the inlet wall on each side.
3. Complete joint penetration butt welds may be substituted for the fillet welds on all anchors.
4. Standard square, hexagon, round or equivalent headed anchors may be substituted for the right angle hooks on the anchors shown on this plan.

TABLE A				
CURB TYPE	NORMAL CURB HEIGHT	CURB BATTER	"a" DIMENSION	"b" DIMENSION
A1-6	6"	1 1/2"	T+7 1/2"	T+6 1/2"
A1-8	8"	2"	T+7"	T+6"
B1-6	6"	4"	T+5"	T+4"
TYPE A DIKE	6"	3"	T+6"	T+5"

Height of curb opening will vary with the type of curb and the depth of the local depression.

D18+	COUNTY	ROUTE	POST MILES TOTAL PROJECT	SHEET TOTAL SHEETS

REGISTERED CIVIL ENGINEER
 July 15, 2016
 PLANS APPROVAL DATE
 THE STATE OF CALIFORNIA OR ITS OFFICERS OR AGENTS SHALL NOT BE RESPONSIBLE FOR THE ACCURACY OR COMPLETENESS OF SCANNED COPIES OF THIS PLAN SHEET.

TO ACCOMPANY PLANS DATED _____

STATE OF CALIFORNIA
DEPARTMENT OF TRANSPORTATION
**PRECAST
DRAINAGE INLETS
TYPES GO AND GDO**
NO SCALE

RSP D73E DATED JULY 15, 2016 SUPPLEMENTS THE STANDARD PLANS BOOK DATED 2015.

REVISED STANDARD PLAN RSP D73E

GENERAL NOTES:

- "H" is measured from top of bottom slab to the normal gutter grade line undepressed at the curb face.
- For "T" wall thickness and reinforcement, see Table C on Revised Standard Plan RSP D73G.
- Wall reinforcement must be placed at the center of wall thickness with horizontal bars placed on the exterior face. Bottom slab concrete cover must be 3" clear on the interior side face unless otherwise noted. Top slab concrete cover must be 2" clear on the exterior face unless otherwise noted. Short independent wall sections or height adjustment rings 6" to 24" high must have a minimum of two #4 horizontal bars. Reinforcement spacing is in inches unless otherwise noted.
- Steps - None required where "H" is less than 2'-6". Where "H" is 2'-6" or more, install steps with lowest rung 1'-0" above the floor and highest rung not more than 6" below bottom of lid. The distance between steps must not exceed 1'-0" and be uniform throughout the length of the wall. Place steps in the wall without an opening. Steps inserts may be substituted for the bar steps. Step Inserts must comply with State Industrial Safety Requirements. See Revised Standard Plan RSP D74 for step details.
- Pipe(s) can be placed in any wall. Adjacent to each side of the opening, place additional reinforcement equivalent to half the interrupted main reinforcement. For larger pipes greater than or equal to 42" diameter, also add 4 diagonal bars, 1 bar each side. Bars must be the same size as the larger of the main vertical or horizontal bars. Extend bars one development length past the intersection with the adjacent diagonal bar, or where bars intersect mid thickness of adjacent wall bottom or top of non-continuous wall, bend ends as required into same plane.
- Set inlet so that grate bars are parallel to direction of principal surface flow.
- Curb section must match adjacent curb.
- Except for inlets used as junction boxes, basin floors must have wood trowel finish and a minimum slope of 4:1, unless otherwise noted, from all directions toward outlet pipe by casting grout on top of the bottom slab. Grout must be placed prior to backfill.
- See Standard Plans D77A and D77B for grate and frame details and weights of miscellaneous iron and steel.
- See Standard Plans D78A and D78B for gutter depression details.
- See Standard Plan A87A and Revised Standard Plan RSP A87B for curb and dike details.
- Details shown apply to metal, concrete and plastic pipe(s).
- The Contractor may use WWR instead of bar reinforcement. The ratio of bar reinforcement to WWR shall be based on the yield strength ratio.
- Seal precast inlets connection openings between wall and pipe with non-shrink grout or resilient connectors as specified in the Special Provisions. Precast inlets shall have mortared connections conforming to details for Type GCP Inlet shown on Standard Plan D75B. See Standard Specifications for mortar composition.
- Where shown, provide precast inlets with separate top sections for final grade adjustment. Provide keyed joints with butyl rubber sealant between the top section and wall, multiple wall sections, and wall and bottom slab. Joint design may vary but must be 1" to 3" in depth. For tongue type joints, tongue down orientation is not allowed. For keyed joints, keyway up, keyway down or tongue up configurations are allowed. Only one key type is allowed for each drainage inlet.
- Non-shrink grout can be used for upper most joint to facilitate final top grade adjustment.
- Provide a level and firm sand bedding on which to place precast inlets. Extend sand bedding under all structure backfill.
- For Integral Base, see Detail "A".
- Perimeter reinforcement must not be smaller than main bars and #4 and serves as a rigid frame to position and attach the required structural reinforcement and may be tack welded at outer corners when using ASTM A706 weldable bars.
- Inlet extensions may be cast in place after placement of main box and placement and compaction of backfill. Concrete strength must be 3.6 ksi minimum. All slab and wall thicknesses must be per Revised Standard Plan RSP D72A. All reinforcement shall extend a minimum of 24" from precast main inlet box.

DESIGN NOTES:

- Design Specifications: AASHTO LRFD Bridge Design Specifications, 6th edition with 2012 Interims and Errata and CA Amendments.
- Live Load (AASHTO LRFD 3.6.1.2): HL-93, consists of design truck or tandem, and design lane load. Dynamic Load Allowance, IM = 33%. Multiple Presence Factor, m = 1.0. Design lane load was excluded in Top Slab design. A wheel load of 8 kips without impact factor was used for top slabs that are above a curb.
- Earth Load:
Vertical pressure = 140 pcf
Lateral pressure:
= 100 pcf for walls with flat embankment
= 140 pcf For walls with slope embankment, 1.5:1 Max
- Downdrag: $\phi = 34^\circ$ and $\gamma_E = 120$ pcf.
- Buoyancy: $\gamma_w = 62.4$ pcf to finished grade.
- Reinforced Concrete: $f'_c = 5.0$ ksi, $f_y = 60.0$ ksi.
- Tables are based on the worst case from the level ground and sloped ground.
- Soil pressures shown are factored per AASHTO LRFD and include self-weight, live load and downdrag.

SPAN "A" OR "B" (IN)	L (IN)
<38	34
38 TO 50	40
51 TO 64	47
65 TO 76	53
77 TO 90	60

DIST	COUNTY	ROUTE	POST MILES TOTAL PROJECT	SHEET TOTAL SHEETS



 REGISTERED CIVIL ENGINEER
 July 15, 2016
 PLANS APPROVAL DATE
 THE STATE OF CALIFORNIA OR ITS OFFICERS OR AGENTS SHALL NOT BE RESPONSIBLE FOR THE ACCURACY OR COMPLETENESS OF SCANNED COPIES OF THIS PLAN SHEET.

TO ACCOMPANY PLANS DATED _____

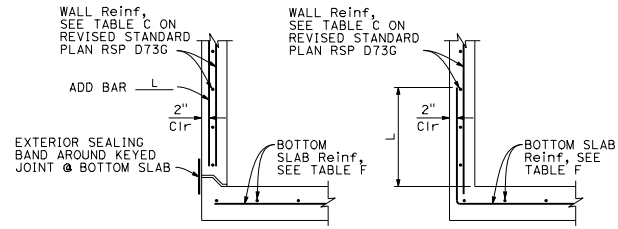

BASE WITH KEYED JOINT INTEGRAL BASE

DETAIL "A"

FOR INTEGRAL BASE, CLEARANCE BETWEEN PIPE PENETRATION AND BASE SLAB MAY BE AS SHOWN IN CIP ALTERNATIVE STANDARD PLAN SHEET.

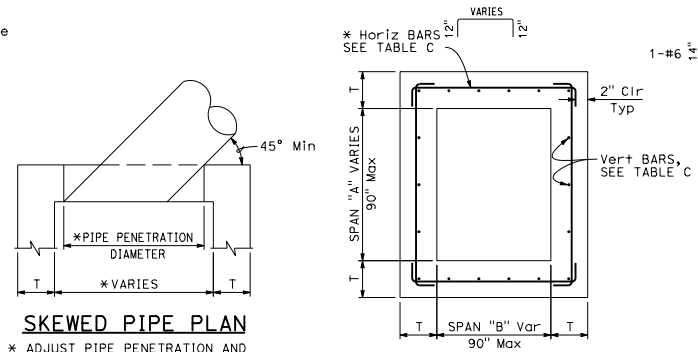

SKEWED PIPE PLAN
* ADJUST PIPE PENETRATION AND BOX WIDTH FOR SKEWED PIPES.

TYPICAL INLET PLAN
* ALTERNATIVE HORIZONTAL BARS

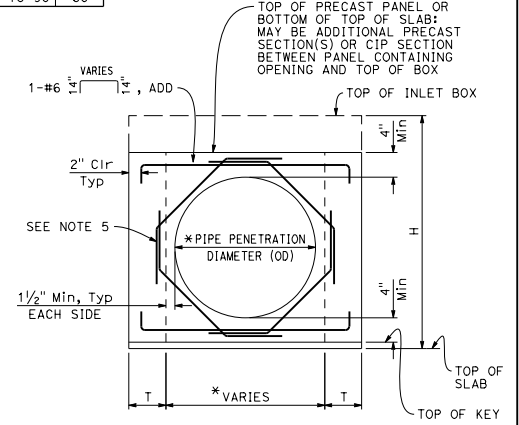

BASE WITH KEYED JOINT

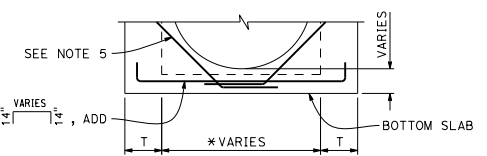

INTEGRAL BASE
FOR DETAILS NOT SHOWN, SEE "BASE WITH KEYED JOINT"

TYPICAL WALL W/ PIPE OPENING
* SEE "SKEWED PIPE PLAN"

STATE OF CALIFORNIA
DEPARTMENT OF TRANSPORTATION

PRECAST DRAINAGE INLET NOTES
NO SCALE

RSP D73F DATED JULY 15, 2016 SUPPLEMENTS THE STANDARD PLANS BOOK DATED 2015.

REVISED STANDARD PLAN RSP D73F

2015 REVISED STANDARD PLAN RSP D73F

DIST	COUNTY	ROUTE	POST MILES TOTAL PROJECT	SHEET NO.	TOTAL SHEETS

 REGISTERED CIVIL ENGINEER
 July 15, 2016
 PLANS APPROVAL DATE
 THE STATE OF CALIFORNIA OR ITS OFFICERS OR AGENTS SHALL NOT BE RESPONSIBLE FOR THE ACCURACY OR COMPLETENESS OF SCANNED COPIES OF THIS PLAN SHEET.

REGISTERED PROFESSIONAL ENGINEER
 Corl M. Dugan
 No. C59976
 Exp. 6-30-18
 CIVIL
 STATE OF CALIFORNIA

TO ACCOMPANY PLANS DATED _____

TABLE A - CONCRETE QUANTITIES

TYPE	H=3'-0" TO 8'-0"		H=8'-1" TO 20'-0"	
	H=3'-0" (CY)	ADDITIONAL CONCRETE PER FOOT (CY)	H=8'-1" (CY)	ADDITIONAL CONCRETE PER FOOT (CY)
G1	0.95	0.220	SEE NOTE 2	SEE NOTE 2
G2*	1.25	0.255	2.55	0.255
G3	1.06	0.220	SEE NOTE 2	SEE NOTE 2
G4 (TYPE 18)*	1.41	0.255	2.71	0.255
G4 (TYPE 24)*	1.36	0.255	2.65	0.255
G5	1.09	0.220	SEE NOTE 2	SEE NOTE 2
G6	1.14	0.220	SEE NOTE 2	SEE NOTE 2
OS	1.28	0.278	2.69	0.278
OL7	1.92	0.278	3.33	0.278
OL10	2.43	0.278	3.84	0.278
OL14	3.16	0.278	4.57	0.278
OL21	4.58	0.278	5.99	0.278
GOL7	2.36	0.313	4.04	0.434
GOL10	2.84	0.313	4.53	0.434
GT1	2.30	0.480	SEE NOTE 2	SEE NOTE 2
GT2	2.71	0.530	5.40	0.530
GT3	2.29	0.480	SEE NOTE 2	SEE NOTE 2
GT4	2.69	0.530	5.39	0.530
GO	1.25	0.245	2.37	0.245
GDO	1.64	0.322	3.37	0.446

* Quantities are based on the minimum interior dimensions.

TABLE B - REINFORCEMENT QUANTITIES

TYPE	H=3'-0" TO 8'-0"		H=8'-1" TO 20'-0"	
	H=3'-0" (LB)	ADDITIONAL REINFORCEMENT PER FOOT (LB)	H=8'-1" (LB)	ADDITIONAL REINFORCEMENT PER FOOT (LB)
G1	88.5	21.90	SEE NOTE 2	SEE NOTE 2
G2*	151.5	24.54	277.4	38.64
G3	92.9	21.90	SEE NOTE 2	SEE NOTE 2
G4 (TYPE 18)*	134.4	24.54	260.3	38.64
G4 (TYPE 24)*	125.1	24.54	251.0	38.64
G5	92.5	21.90	SEE NOTE 2	SEE NOTE 2
G6	92.5	21.90	SEE NOTE 2	SEE NOTE 2
OS	145.8	35.57	327.8	49.60
OL7	328.0	35.57	510.0	49.60
OL10	467.5	35.57	649.5	49.60
OL14	667.5	35.57	849.5	49.60
OL21	1056.1	35.57	1238.1	49.60
GOL7	474.7	45.17	706.8	74.02
GOL10	604.9	45.17	836.9	74.02
GT1	349.0	80.48	SEE NOTE 2	SEE NOTE 2
GT2	403.7	86.82	849.1	135.15
GT3	347.0	80.48	SEE NOTE 2	SEE NOTE 2
GT4	403.7	86.82	849.1	135.15
GO	99.8	23.75	221.7	37.46
GDO	208.8	46.22	446.2	75.61

* Quantities are based on the minimum interior dimensions.

TABLE D

INLET	CURB USED IN QUANTITIES
G1	-
G2	-
G3	A1-6
G4 (Type 18)	A1-6
G4 (Type 24)	A1-6
G5	B1-4
G6	1/2E
OS	-
OL7	-
OL10	-
OL14	-
OL21	-
GOL7	-
GOL10	-
GT1	D-6
GT2	E
GT3	A2-8
GT4	A2-8
GO	-
GDO	-

TABLE C - WALL REINFORCEMENT

TYPE	H ≤ 8'-0" (T=8", UON)			8'-0" < H ≤ 20'-0" (T=8", UON)		
	HORIZONTAL	VERTICAL	*ADD	HORIZONTAL	VERTICAL	*ADD
OS	#406	#308	#308	#404 (T=6")	#308	#308
OL	#406	#308	#308	#404 (T=6")	#308	#308
GOL	#405	#308	#308	#505	#306	#306
G1 (H ≤ 6'-9")	#409	#308	#308	-	-	-
G2 & G4 (a** ≤ 38")	#409	#308	#308	#405 (T=6")	#308	#308
G2 & G4 (38" < a** ≤ 50")	#406	#308	#308	#404 (T=6")	#308	#308
G2 & G4 (50" < a** ≤ 64")	#405	#308	#308	#505	#306	#306
G2 & G4 (64" < a** ≤ 76")	#507 (T=8")	#306	#306	#504	#306	#506
G2 & G4 (76" < a** ≤ 90")	#505 (T=8")	#306	#306	#503	#306	#506
G3 (H ≤ 6'-9")	#409	#308	#308	-	-	-
G5 (H ≤ 6'-9")	#409	#308	#308	-	-	-
G6 (H ≤ 6'-9")	#409	#308	#308	-	-	-
GT1 (H ≤ 6'-9")	#505 (T=8")	#306	#306	-	-	-
GT2	#505 (T=8")	#306	#306	#503	#306	#506
GT3 (H ≤ 6'-9")	#505 (T=8")	#306	#306	-	-	-
GT4	#505 (T=8")	#306	#306	#503	#306	#506
GO	#409	#308	#308	#405 (T=6")	#308	#308
GDO	#405	#308	#308	#505	#306	#306

* See Detail A on Revised Standard Plan RSP D73F for additional vertical bars at the base.
** a = Larger interior span

TABLE E

SOIL PRESSURE BELOW BASE SLAB (ksf)		
TYPE	H ≤ 8'-0"	8'-0" < H ≤ 20'-0"
OS	2.89	5.68
OL*	2.89	5.68
GOL*	2.36	4.93
G1 (H ≤ 6'-9")	3.51	-
G2 & G4 (a** ≤ 38")	2.96	5.79
G2 & G4 (38" < a** ≤ 50")	2.21	4.51
G2 & G4 (50" < a** ≤ 64")	3.19	4.89
G2 & G4 (64" < a** ≤ 76")	2.50	4.23
G2 & G4 (76" < a** ≤ 90")	2.04	3.56
G3 (H ≤ 6'-9")	3.51	-
G5 (H ≤ 6'-9")	3.51	-
G6 (H ≤ 6'-9")	3.51	-
GT1 (H ≤ 6'-9")	3.41	-
GT2	3.60	6.42
GT3 (H ≤ 6'-9")	3.41	-
GT4	3.60	6.42
GO	3.37	6.46
GDO	2.48	7.30

* Main Box
** a = Larger interior span

NOTES:

- No deduction or adjustment was made to the quantities of concrete and reinforcement for pipe openings, floor alternatives or curb type.
- Maximum allowable height is 6'-9".
- Quantities are approximate and for design purposes only.
- Design is based on envelope of level and sloped ground.

TABLE F

BASE SLAB REINFORCEMENT (T=8", UON)		
TYPE	H ≤ 8'-0"	8'-0" < H ≤ 20'-0"
OS	#408 (EW)	#405 (EW)
OL*	#408 (EW)	#405 (EW)
GOL*	#406 (EW)	#404 (EW)
G1 (H ≤ 6'-9")	#4010 (EW)	-
G2 & G4 (a** ≤ 38")	#4010 (EW)	#406 (EW)
G2 & G4 (38" < a** ≤ 50")	#408 (EW)	#405 (EW)
G2 & G4 (50" < a** ≤ 64")	#406 (EW)	#404 (EW)
G2 & G4 (64" < a** ≤ 76")	#405 (EW)	#403 (EW)
G2 & G4 (76" < a** ≤ 90")	#404 (EW)	#503 (EW)
G3 (H ≤ 6'-9")	#4010 (EW)	-
G5 (H ≤ 6'-9")	#4010 (EW)	-
G6 (H ≤ 6'-9")	#4010 (EW)	-
GT1 (H ≤ 6'-9")	#404 (EW)	-
GT2	#404 (EW)	#503 (EW)
GT3 (H ≤ 6'-9")	#404 (EW)	-
GT4	#404 (EW)	#503 (EW)
GO	#4010 (EW)	#406 (EW)
GDO	#406 (EW)	#404 (EW)

(EW) Each Way
* Main Box
** a = Larger interior span

STATE OF CALIFORNIA
DEPARTMENT OF TRANSPORTATION
**PRECAST
DRAINAGE INLET TABLES**
NO SCALE

RSP D73G DATED JULY 15, 2016 SUPPLEMENTS THE STANDARD PLANS BOOK DATED 2015.

REVISED STANDARD PLAN RSP D73G

DIST	COUNTY	ROUTE	POST MILES TOTAL PROJECT	SHEET TOTAL SHEETS



 REGISTERED CIVIL ENGINEER
 July 15, 2016
 PLANS APPROVAL DATE
 THE STATE OF CALIFORNIA OR ITS OFFICERS OR AGENTS SHALL NOT BE RESPONSIBLE FOR THE ACCURACY OR COMPLETENESS OF SCANNED COPIES OF THIS PLAN SHEET.

TO ACCOMPANY PLANS DATED _____

FACE ANGLE DETAIL "A"	
LENGTH OF CURB OPENING	No. OF ANCHORS
3'-6" OR LESS	2
7'-0"	3
10'-0"	4
14'-0"	5
21'-0"	7

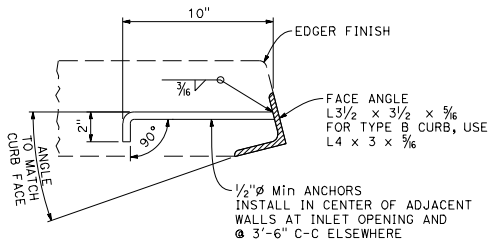

DETAIL "A"

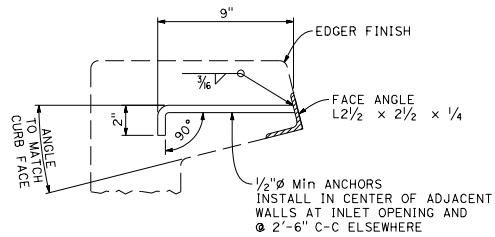

DETAIL "B"

FACE ANGLE AND ANCHOR

NOTE:

- When shown on the project plans, place a 3/4" plain round protection bar horizontally across the length of the opening and bend back 4" into the inlet wall on each side.

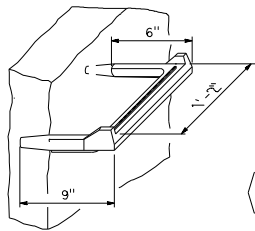

STEP INSERT

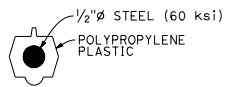

TYPICAL SECTION
(STEP INSERT)

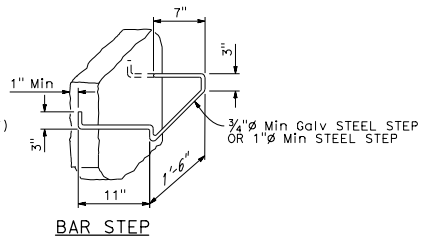

BAR STEP

STEP DETAILS

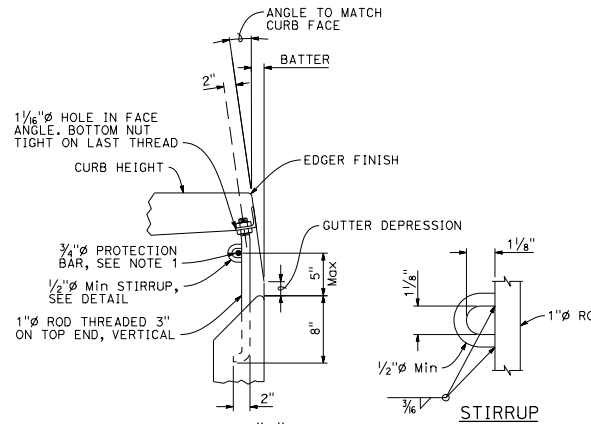

DETAIL "C"

CURB SUPPORT

CURB SUPPORTS SHALL BE EVENLY SPACED AND MINIMAL IN NUMBER SUCH THAT MAXIMUM SPAN OF UNSUPPORTED CURB IS 7'-0".

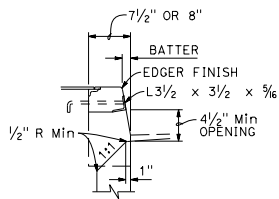

TYPE A CURBS

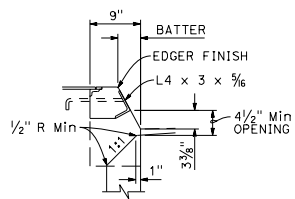

TYPE B CURBS

CURB OPENING DETAILS

STATE OF CALIFORNIA
DEPARTMENT OF TRANSPORTATION
DRAINAGE INLET DETAILS

NO SCALE

RSP D74 DATED JULY 15, 2016 SUPPLEMENTS THE STANDARD PLANS BOOK DATED 2015.

REVISED STANDARD PLAN RSP D74

2015 REVISED STANDARD PLAN RSP D74

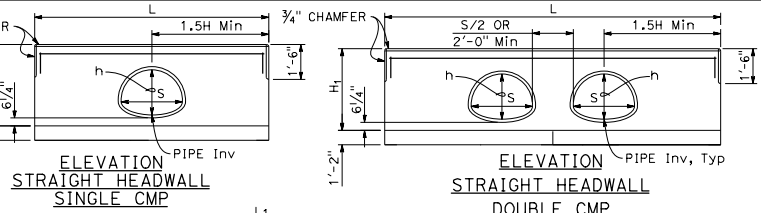
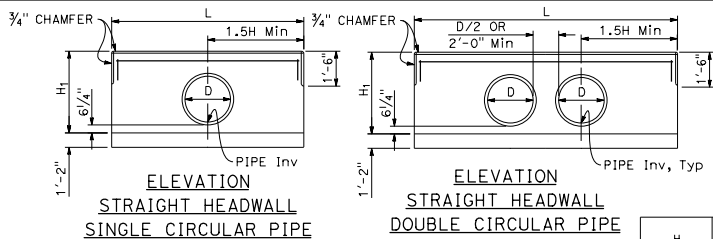

DIST	COUNTY	ROUTE	POST MILES TOTAL PROJECT	SHEET TOTAL SHEETS

REGISTERED CIVIL ENGINEER
 July 21, 2017
 PLANS APPROVAL DATE
 THE STATE OF CALIFORNIA OR ITS OFFICERS OR AGENTS SHALL NOT BE RESPONSIBLE FOR THE ACCURACY OR COMPLETENESS OF SCANNED COPIES OF THIS PLAN SHEET.

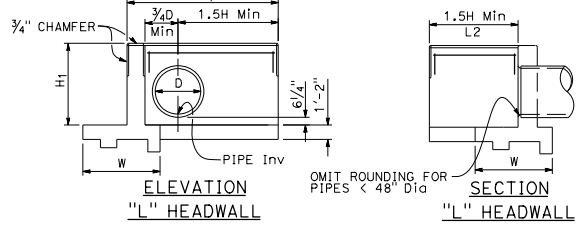

H	CIRCULAR PIPE SIZE D	CMP ARCH SIZE S x h
2'-8"	12"	-
2'-11"	15"	21" x 15"
3'-2"	18"	24" x 18"
3'-5"	21"	28" x 20"
3'-8"	24"	35" x 24"
3'-11"	27"	-
4'-2"	30"	42" x 29"
4'-5"	33"	49" x 33"
4'-8"	36"	-
4'-11"	39"	57" x 38"
5'-2"	42"	64" x 43"
5'-5"	45"	-
5'-8"	48"	71" x 47"
5'-11"	51"	-
6'-2"	54"	-

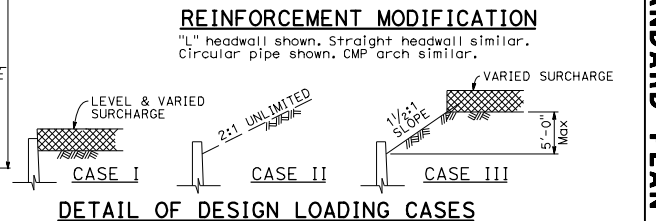
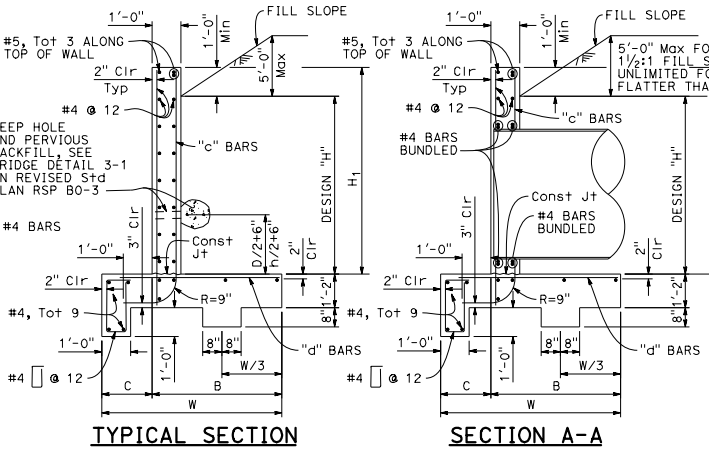
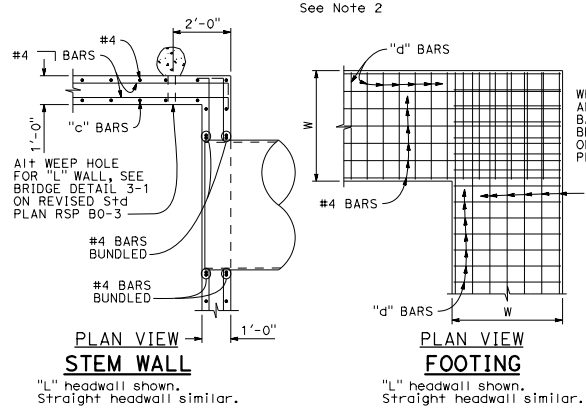
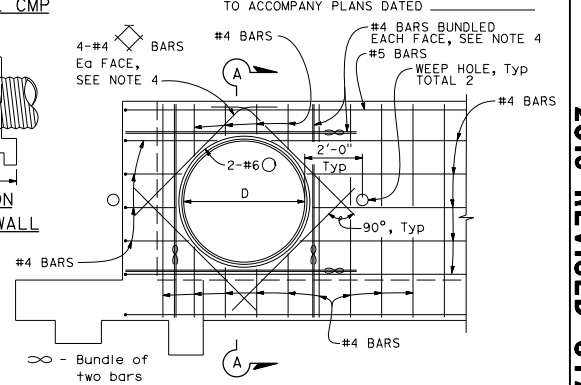
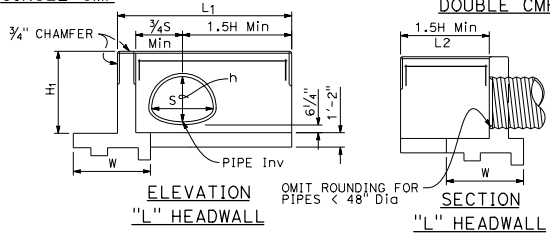

H	2'-8"	2'-11"	3'-2"	3'-5"	3'-8"	3'-11"	4'-2"	4'-5"	4'-8"	4'-11"	5'-2"	5'-5"	5'-8"	5'-11"	6'-2"	
W	4'-7"	4'-9"	4'-10"	5'-0"	5'-1"	5'-2"	5'-3"	5'-5"	5'-6"	5'-7"	5'-8"	5'-9"	5'-11"	6'-0"	6'-3"	
C	1'-2"	1'-2"	1'-2"	1'-3"	1'-3"	1'-3"	1'-4"	1'-4"	1'-4"	1'-5"	1'-5"	1'-6"	1'-6"	1'-6"	1'-9"	
B	3'-5"	3'-7"	3'-8"	3'-9"	3'-10"	3'-11"	4'-0"	4'-1"	4'-2"	4'-3"	4'-3"	4'-4"	4'-5"	4'-6"	4'-6"	
"c" BARS	#4 @ 12	#4 @ 12	#4 @ 12	#4 @ 12	#4 @ 12	#4 @ 12	#4 @ 12	#4 @ 12	#4 @ 12	#4 @ 12	#4 @ 12	#4 @ 12	#4 @ 12	#4 @ 12	#4 @ 12	
"d" BARS	#4 @ 12	#4 @ 8	#4 @ 8	#4 @ 8	#4 @ 8	#5 @ 12	#5 @ 12	#5 @ 12	#5 @ 12	#5 @ 8	#5 @ 8	#5 @ 8	#5 @ 8	#6 @ 8	#6 @ 8	
* Conc CY/LF	0.404	0.412	0.415	0.423	0.426	0.430	0.433	0.440	0.444	0.448	0.451	0.455	0.462	0.466	0.477	
* Reinf LB/LF	23	24	24	25	26	27	27	28	28	29	29	30	31	31	32	
**CASE I	Ser (a'o, B')	0.79, 4.66	0.83, 4.57	0.88, 4.58	0.89, 4.73	0.93, 4.74	0.93, 4.75	1.02, 4.75	1.02, 4.92	1.07, 4.93	1.11, 4.94	1.12, 4.98	1.16, 4.99	1.17, 5.16	1.21, 5.18	1.15, 5.53
	Str (a'o, B')	1.48, 1.75	1.53, 1.80	1.65, 1.76	1.64, 1.88	1.76, 1.85	1.89, 1.83	2.02, 1.80	1.97, 1.95	2.08, 1.94	2.20, 1.93	2.28, 1.92	2.39, 1.92	2.31, 2.08	2.41, 2.09	2.17, 2.41
	Extr (a'o, B')	0.65, 4.16	0.68, 4.27	0.72, 4.29	0.74, 4.44	0.78, 4.46	0.82, 4.47	0.86, 4.47	0.87, 4.63	0.92, 4.63	0.96, 4.64	0.98, 4.69	1.03, 4.69	1.04, 4.84	1.09, 4.84	1.05, 5.18
**CASE II	Ser (a'o, B')	0.41, 4.52	0.44, 4.67	0.48, 4.73	0.51, 4.90	0.55, 4.95	0.59, 5.00	0.63, 5.04	0.65, 5.21	0.70, 5.26	0.74, 5.30	0.77, 5.37	0.81, 5.40	0.83, 5.58	0.88, 5.61	0.86, 5.96
	Str (a'o, B')	1.05, 4.49	1.10, 4.64	1.15, 4.69	1.19, 4.86	1.24, 4.90	1.30, 4.94	1.36, 4.98	1.39, 5.15	1.46, 5.18	1.52, 5.22	1.56, 5.28	1.62, 5.31	1.62, 5.48	1.72, 5.51	1.69, 5.85
	Extr (a'o, B')	0.98, 3.90	1.03, 4.00	1.10, 4.01	1.13, 4.15	1.19, 4.15	1.26, 4.15	1.33, 4.14	1.37, 4.29	1.44, 4.27	1.52, 4.26	1.57, 4.29	1.65, 4.28	1.68, 4.41	1.77, 4.40	1.72, 4.71
**CASE III	Ser (a'o, B')	0.81, 4.53	0.84, 4.73	0.88, 4.76	0.70, 4.91	0.74, 4.91	0.79, 4.94	0.83, 4.93	0.85, 5.08	1.17, 4.03	1.23, 4.03	1.27, 4.06	1.34, 4.02	1.36, 4.15	1.43, 4.11	1.36, 4.45
	Str (a'o, B')	0.99, 4.28	1.04, 4.67	1.10, 4.69	1.13, 4.83	1.19, 4.82	1.25, 4.83	1.32, 4.82	1.35, 4.95	2.02, 2.66	2.16, 2.62	2.25, 2.59	2.44, 2.48	2.49, 2.54	2.70, 2.44	2.50, 2.72
	Extr (a'o, B')	0.90, 3.88	0.95, 3.93	1.01, 3.91	1.04, 4.02	1.11, 3.97	1.18, 3.92	1.25, 3.90	1.28, 4.00	1.35, 3.94	1.43, 3.92	1.51, 3.91	1.55, 3.87	1.58, 3.97	1.67, 3.91	1.60, 4.22

REINFORCED CONCRETE HEADWALL
 Quantities do not include added diagonals and do not consider pipe occupancy.
 NOTE: Reinforced Concrete: $f_y = 60,000$ psi
 Earth Density: 120 pcf
 Equivalent Fluid Pressure: 36 pcf

NOTES:
 1. Length of wall from C pipe to end of wall is 1.5H Min. The ends of headwall need to be embedded into the slope by two feet.
 2. Single circular pipe or single CMP shown for "L" headwall. For double pipe in "L" headwall, see "ELEVATION STRAIGHT HEADWALL DOUBLE CIRCULAR PIPE" or "ELEVATION STRAIGHT HEADWALL DOUBLE CMP" detail for additional information.
 3. Cable railing to be installed on top of headwall when shown on Project Plans. See Standard Plan B11-47 for cable railing details.
 4. Adjacent to each side of the opening, place additional reinforcement equivalent to half the interrupted main reinforcement. For pipes 42" diameter and greater, add 4 diagonals, 1 bar each side. Extend bars one development length past the intersection with the adjacent diagonal bar, or where bars intersect mid thickness of adjacent wall, bottom slab or top of wall, bend ends as required into same plane.
 5. Quantities are approximate and for design purposes only. No deduction is made for pipe or arch occupancy.

STATE OF CALIFORNIA
 DEPARTMENT OF TRANSPORTATION
**PIPE CULVERT HEADWALLS
 STRAIGHT AND "L"**
 NO SCALE
 RSP D89 DATED JULY 21, 2017 SUPERSEDES RSP D89 DATED JULY 15, 2016 AND STANDARD PLAN D89 DATED OCTOBER 30, 2015 - PAGE 205 OF THE STANDARD PLANS BOOK DATED 2015.
REVISED STANDARD PLAN RSP D89

2015 REVISED STANDARD PLAN RSP D89

DIST	COUNTY	ROUTE	POST MILES TOTAL PROJECT	SHEET TOTAL NO. SHEETS

Raymond Don Isztoo
 REGISTERED CIVIL ENGINEER
 July 15, 2016
 PLANS APPROVAL DATE
 No. C37332
 Exp. 6-30-18
 CIVIL
 STATE OF CALIFORNIA

THE STATE OF CALIFORNIA OR ITS OFFICERS
 OR AGENTS SHALL NOT BE RESPONSIBLE FOR
 THE ACCURACY OR COMPLETENESS OF SCANNED
 COPIES OF THIS PLAN SHEET.

TO ACCOMPANY PLANS DATED _____

NOTES:

1. Lateral support, #4 bar, to be placed on both sides of slotted plastic pipe throat.
2. Slot plastic pipe cross section is a generic shape. Shape shall conform to allowable manufacturer's cross sections.

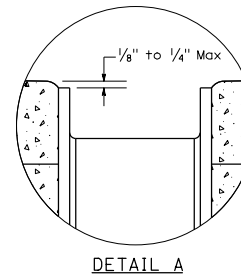
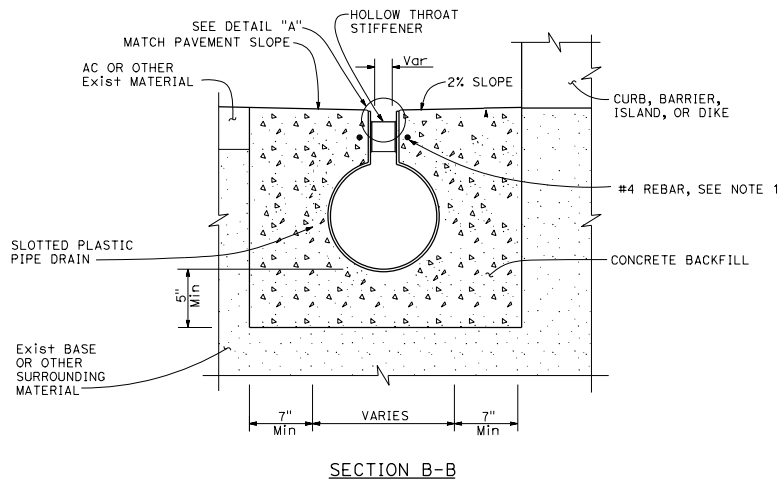
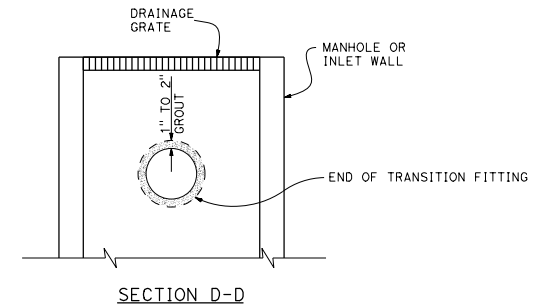
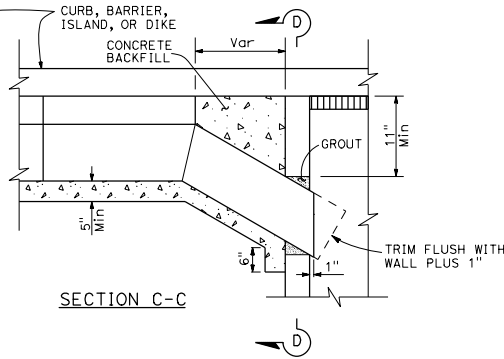
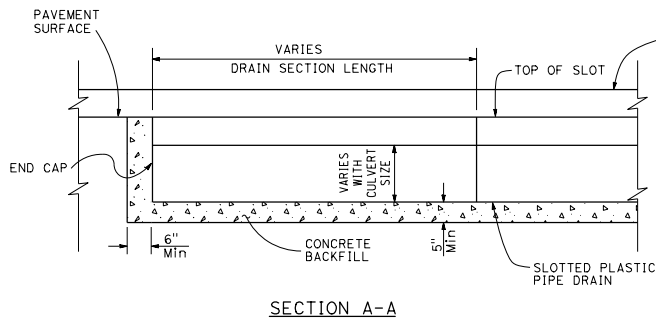
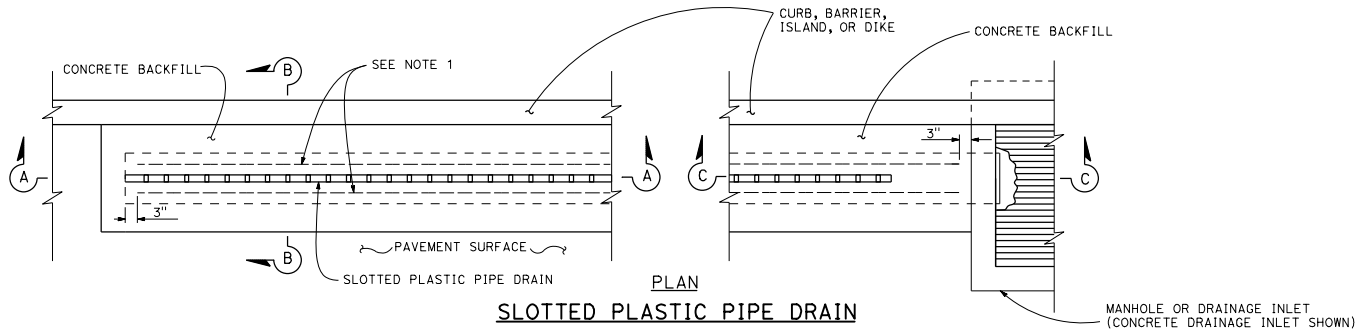

STATE OF CALIFORNIA
DEPARTMENT OF TRANSPORTATION
**SLOTTED PLASTIC PIPE
DRAIN DETAILS**
NO SCALE

RSP D98D DATED JULY 15, 2016 SUPPLEMENTS THE STANDARD PLANS BOOK DATED 2015.

REVISED STANDARD PLAN RSP D98D

2015 REVISED STANDARD PLAN RSP D98D

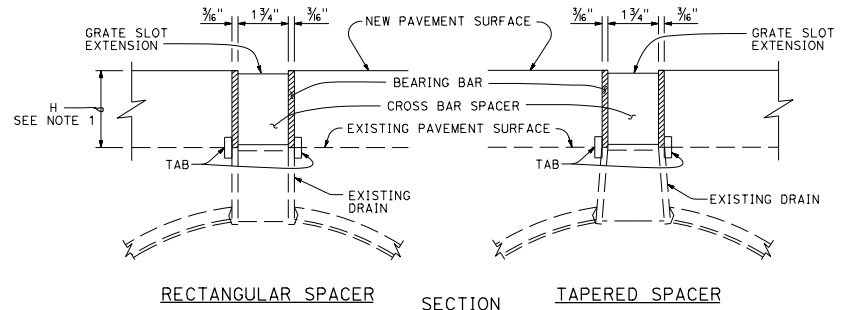

SECTION
RECTANGULAR SPACER **SECTION** **TAPERED SPACER**
SLOTTED CORRUGATED STEEL PIPE
Grate slot extension

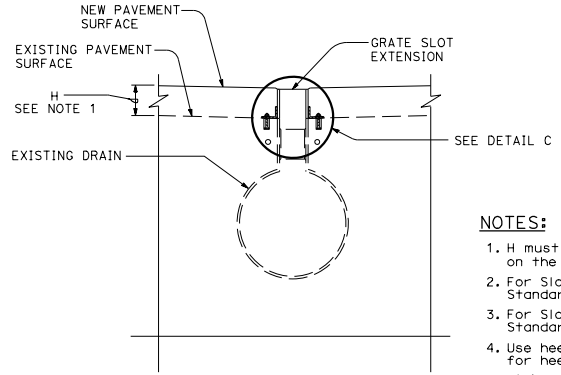

SECTION
SLOTTED PLASTIC PIPE
Grate slot extension

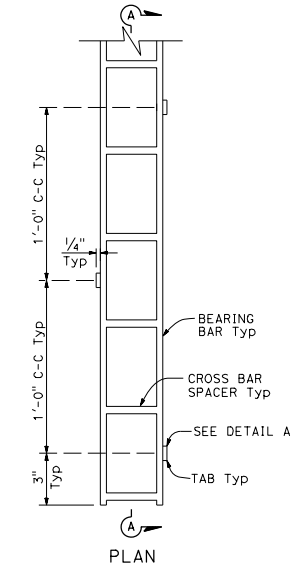
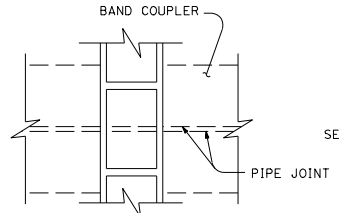

PLAN
SLOTTED CORRUGATED STEEL PIPE
Grate slot extension

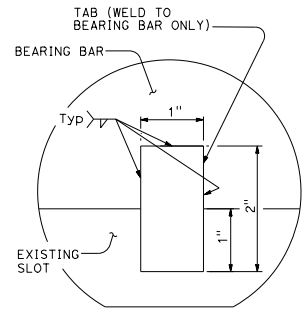
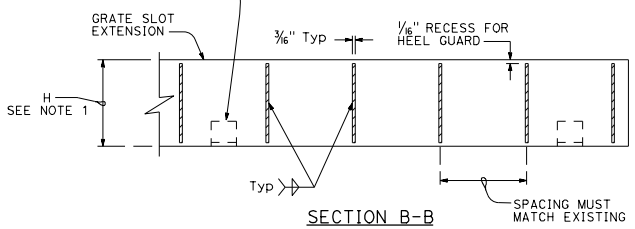
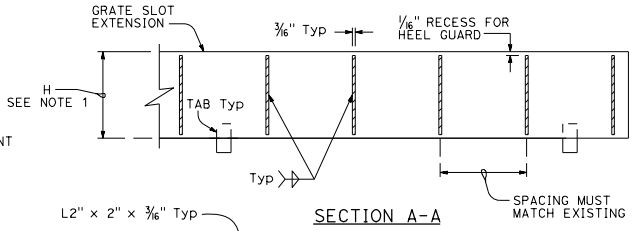

DETAIL A
Tab alignment

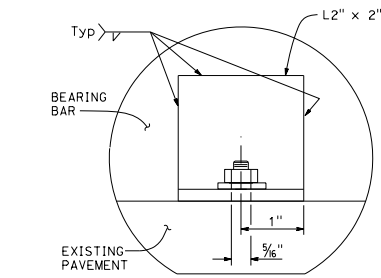

DETAIL B
Angle alignment

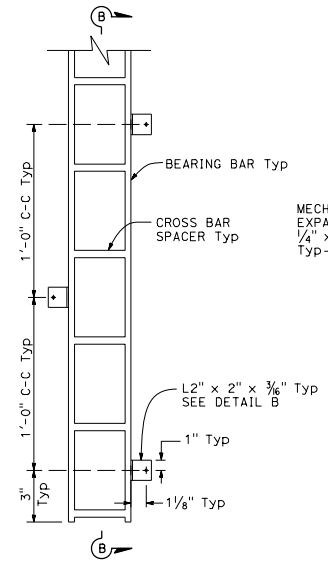

PLAN
SLOTTED PLASTIC PIPE
Grate slot extension

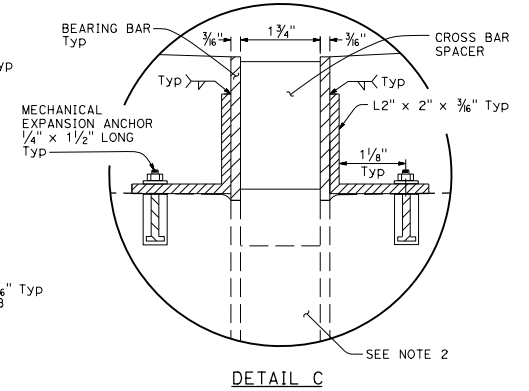

DETAIL C

STATE OF CALIFORNIA
DEPARTMENT OF TRANSPORTATION
**SLOTTED PIPE GRATE
EXTENSION DETAILS**
NO SCALE

RSP D98F DATED JANUARY 20, 2017 SUPERSEDES STANDARD PLAN D98F
DATED OCTOBER 30, 2015 - PAGE 226 OF THE STANDARD PLANS BOOK DATED 2015.

REVISED STANDARD PLAN RSP D98F

DIST	COUNTY	ROUTE	POST MILES TOTAL PROJECT	SHEET NO.	TOTAL SHEETS

Raymond Don Isztos
REGISTERED CIVIL ENGINEER
January 20, 2017
PLANS APPROVAL DATE
THE STATE OF CALIFORNIA OR ITS OFFICERS OR AGENTS SHALL NOT BE RESPONSIBLE FOR THE ACCURACY OR COMPLETENESS OF SCANNED COPIES OF THIS PLAN SHEET.

REGISTERED PROFESSIONAL ENGINEER
Raymond Don Isztos
No. C37332
Exp. 6-30-18
CIVIL
STATE OF CALIFORNIA

TO ACCOMPANY PLANS DATED _____

NOTES:

- H must be a minimum of 2 1/2", or otherwise shown on the plans.
- For Slotted Plastic Pipe Drain Details, see Revised Standard Plan RSP D98D.
- For Slotted Corrugated Steel Pipe Drain Details, see Standard Plans D98A and D98B.
- Use heel guard when shown. See Standard Plan D98B for heel guard details.
- Minimum grate slot extension length is 80".
- The top corners of the grate slot extension's bearing bars must not vary from a straight line more than 1/2" in 20'-0".
- Cross bar spacers must be welded to the grate slot extension's bearing bars to achieve a minimum tensile strength of 12,000 LB normal to the longitudinal axis of the bearing bars.

2015 REVISED STANDARD PLAN RSP D98F

DIST	COUNTY	ROUTE	POST MILES TOTAL PROJECT	SHEET NO.	TOTAL SHEETS

Raymond Don Isztog
 REGISTERED CIVIL ENGINEER
 No. C37332
 Exp. 6-30-18
 CIVIL
 STATE OF CALIFORNIA

PLANS APPROVAL DATE
 April 20, 2018
 THE STATE OF CALIFORNIA OR ITS OFFICERS OR AGENTS SHALL NOT BE RESPONSIBLE FOR THE ACCURACY OR COMPLETENESS OF SCANNED COPIES OF THIS PLAN SHEET.

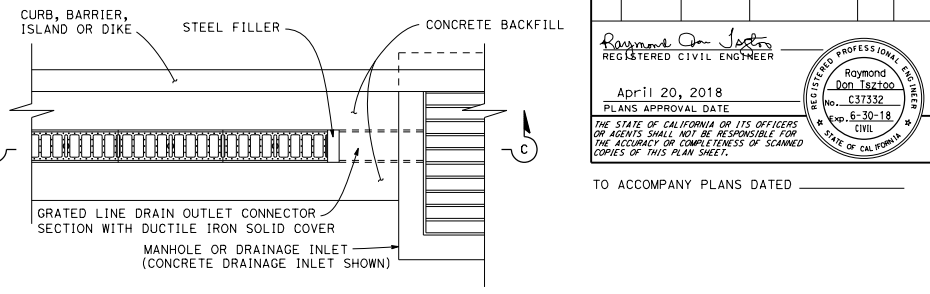
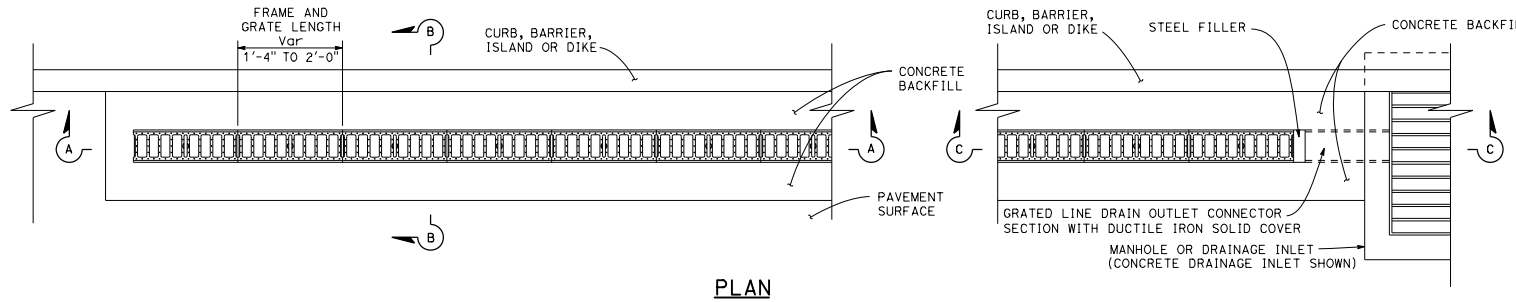

PLAN

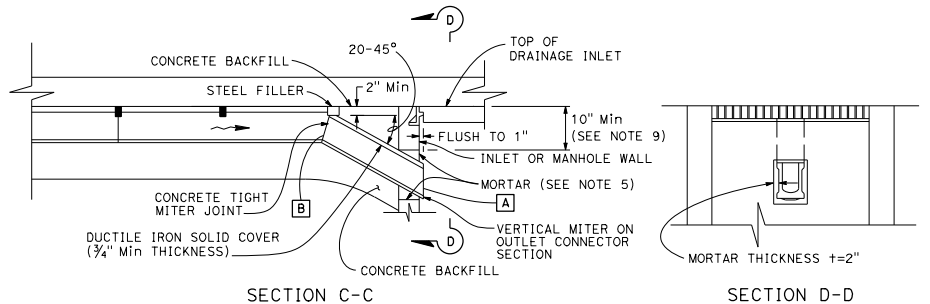
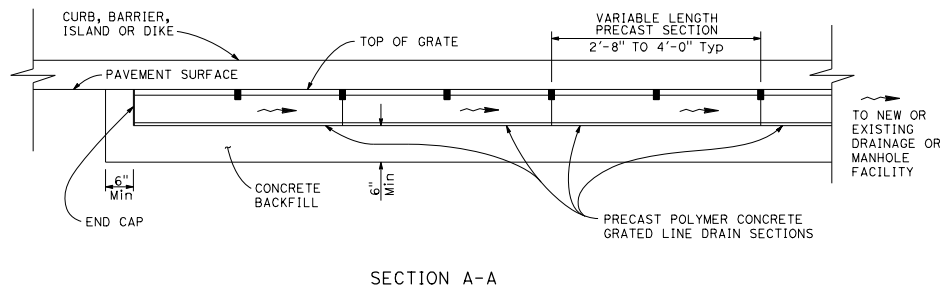

SECTION A-A

SECTION C-C

SECTION D-D

NOTES:

1. See Quantity Sheets for discharge capacity requirements.
2. Discharge capacity (cfs) at point A must be equivalent to maximum channel discharge capacity of grated line drain at point B.
3. Precast polymer concrete drain sections are available in non-sloped uniform depth sections 4 1/8" to 12" or in 0.6 percent pre-sloped sections with graduated depths from 4 1/8" to 12". See Project Plans for trench sections to be installed.
4. Nominal dimensions shown. Allowable tolerance ± 2%.
5. For GMP inlet connection, seal field joint with a pliable mixture of sand, portland cement and emulsified asphalt (mixture of 1 part portland cement, 3-5 parts sand and 1/2 part SSI emulsified asphalt).
6. Within designated pedestrian paths of travel, the maximum grate opening in the direction of pedestrian traffic must not exceed 1/2".
7. Grate patterns may vary from detail shown. See Special Provisions.
8. 3/8" maximum gap between adjacent gratings.
9. Contractor to field verify minimum depth to avoid conflict with inlet top.

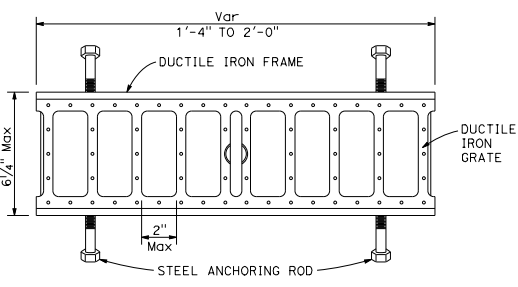
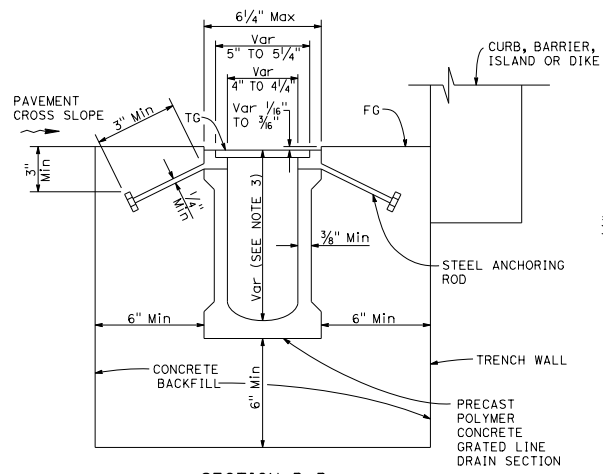

FRAME AND GRATE DETAIL

See Notes 6, 7 and 8

SECTION B-B

(Precast graded line drain with non-integral frame)

STATE OF CALIFORNIA
 DEPARTMENT OF TRANSPORTATION
**GRATED LINE DRAIN
 DETAILS No. 1 - POLYMER
 CONCRETE, 4" NOMINAL WIDTH**
 NO SCALE

RSP D98G DATED APRIL 20, 2018 SUPERSEDES RSP D98G
 DATED JANUARY 20, 2017 THAT SUPPLEMENTS THE STANDARD PLANS BOOK DATED 2015.

REVISED STANDARD PLAN RSP D98G

2015 REVISED STANDARD PLAN RSP D98G

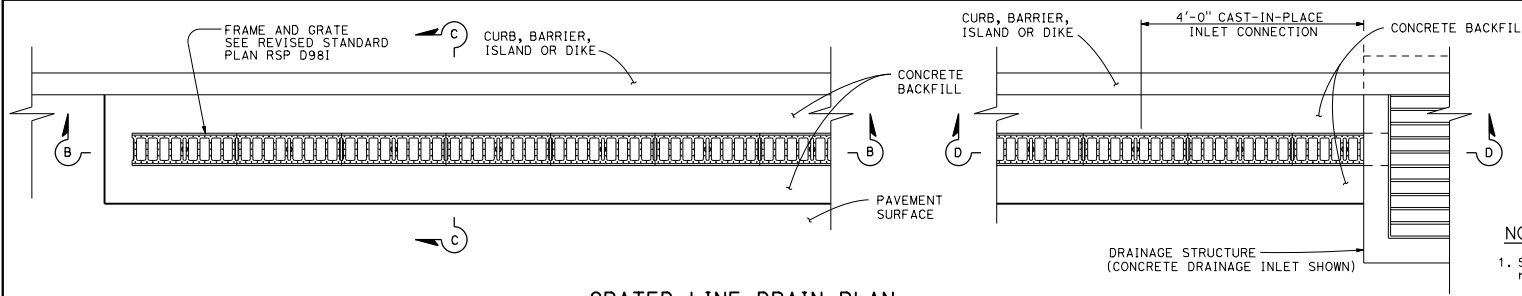

GRATED LINE DRAIN PLAN

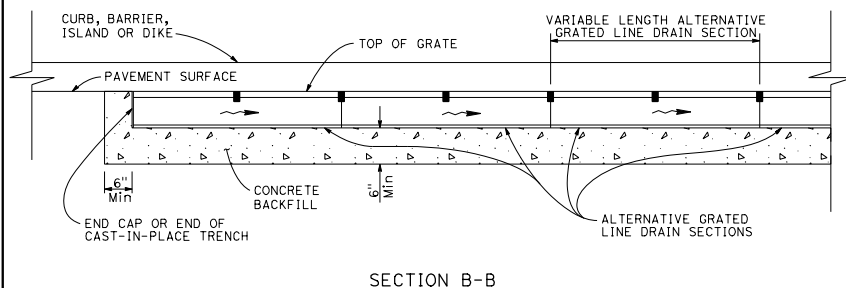

SECTION B-B

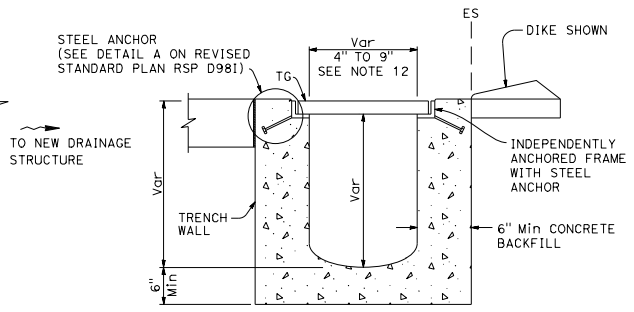

SECTION E-E

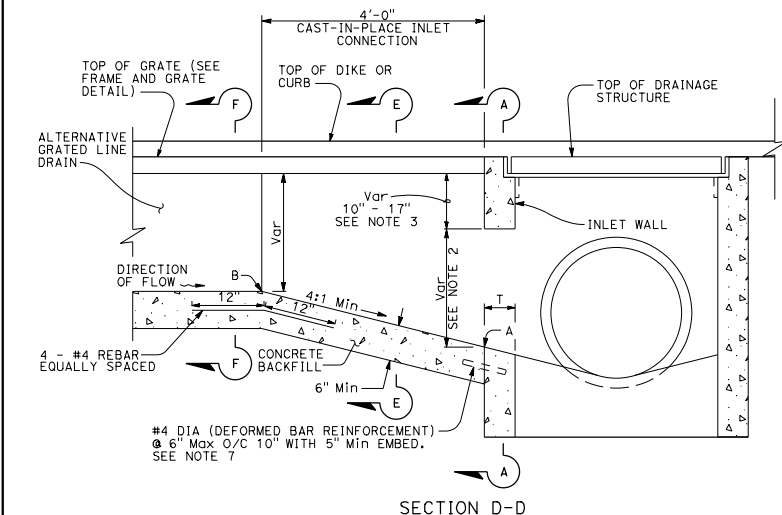

SECTION D-D

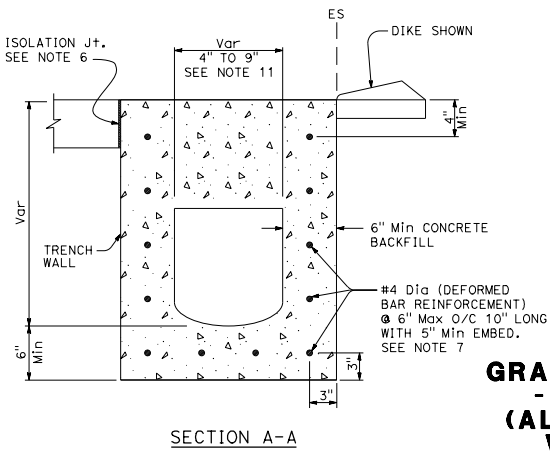

SECTION A-A

DIST	COUNTY	ROUTE	POST MILES TOTAL PROJECT	SHEET NO.	TOTAL SHEETS

Raymond Don Jordan
REGISTERED CIVIL ENGINEER
No. C37332
PLANS APPROVAL DATE
January 20, 2017
THE STATE OF CALIFORNIA OR ITS OFFICERS OR AGENTS SHALL NOT BE RESPONSIBLE FOR THE ACCURACY OR COMPLETENESS OF SCANNED COPIES OF THIS PLAN SHEET.

TO ACCOMPANY PLANS DATED _____

NOTES:

1. See Quantity Sheets for discharge capacity requirements.
2. Discharge capacity (cfs) at point A must be equivalent to maximum channel discharge capacity of grated line drain at point B.
3. Contractor to field verify minimum depth to avoid conflict with inlet top.
4. Grate patterns may vary from details shown. See special provisions.
5. See Revised Standard Plan RSP D986 for 4" polymer concrete grated line details.
6. Within PCC pavement, a 0.5" isolation joint must be made between pavement and concrete backfill. See isolation joint details on Standard Plans P45 and P46.
7. Bottom row of dowels to match inlet connection slope with 2" Min clear to inside of box. Place other dowels normal to inlet wall with 1 1/2" Min clear to inside of box. (When T = 6" use 4 1/2" Min embed)
8. Channel section shape and frame and grate configuration may vary.
9. Nominal dimensions shown. Allowable tolerances ±2%.
10. 3/16" maximum gap between adjacent grates.
11. Minimum channel width must be equal or greater than maximum channel width of grated line drain section.
12. See Revised Standard Plan RSP D981 for Section C-C and Section F-F.

STATE OF CALIFORNIA
DEPARTMENT OF TRANSPORTATION
GRATED LINE DRAIN DETAILS No. 2
- INLET CONNECTION DETAILS
(ALL TYPES EXCEPT 4" NOMINAL WIDTH POLYMER CONCRETE)

NO SCALE

RSP D98H DATED JANUARY 20, 2017 SUPPLEMENTS THE STANDARD PLANS BOOK DATED 2015.

REVISED STANDARD PLAN RSP D98H

2015 REVISED STANDARD PLAN RSP D98H

DIST	COUNTY	ROUTE	POST MILES TOTAL PROJECT	SHEET TOTAL SHEETS

Raymond Don Isztog
 REGISTERED CIVIL ENGINEER
 No. C37332
 Exp. 6-30-18
 CIVIL
 STATE OF CALIFORNIA

January 20, 2017
 PLANS APPROVAL DATE
 THE STATE OF CALIFORNIA OR ITS OFFICERS OR AGENTS SHALL NOT BE RESPONSIBLE FOR THE ACCURACY OR COMPLETENESS OF SCANNED COPIES OF THIS PLAN SHEET.

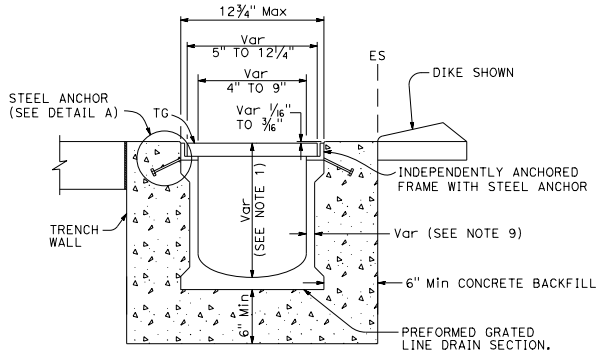

SECTION C-C
(See Note 1)

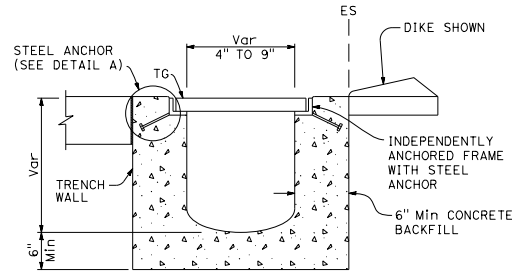

CAST-IN-PLACE ALTERNATIVE

SECTION C-C
(See Note 1)

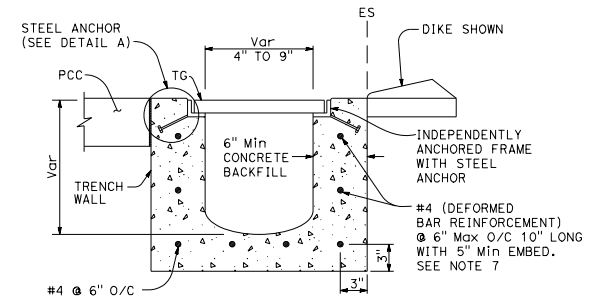

SECTION F-F
FOR CAST-IN-PLACE AND PRECAST INLETS
(See Note 1)

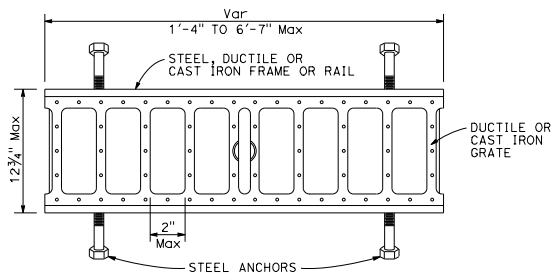

FRAME AND GRATE DETAIL
(See Note 1)

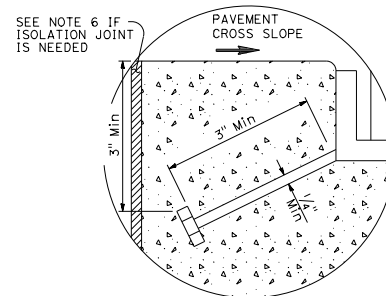

DETAIL A

NOTE:

1. See Revised Standard Plan RSP D98H for corresponding notes.

STATE OF CALIFORNIA
DEPARTMENT OF TRANSPORTATION

**GRADED LINE DRAIN DETAILS No. 3
(ALL TYPES EXCEPT 4" NOMINAL
WIDTH POLYMER CONCRETE)**

NO SCALE

RSP D981 DATED JANUARY 20, 2017 SUPPLEMENTS THE STANDARD PLANS BOOK DATED 2015.

REVISED STANDARD PLAN RSP D981

DIST	COUNTY	ROUTE	POST MILES TOTAL PROJECT	SHEET TOTAL SHEETS

Raymond Don Justice
 REGISTERED CIVIL ENGINEER
 January 20, 2017
 PLANS APPROVAL DATE
 No. C37332
 Exp. 6-30-18
 CIVIL
 STATE OF CALIFORNIA

TO ACCOMPANY PLANS DATED _____
 5/8" Dia x 6" SHEAR STUDS @ 6" OC WITH FULL PENETRATION BUTT WELDS
 #4 #4 TOT 4
 3/2" x 3/2" x 3/8" ANGLE (LENGTH = GRATE WIDTH + 4")
 STEEL PLATE (GRATE WIDTH + 4") x 39" x 1/4"
 SEE NOTE 2
 17" Min
 4 1/2"

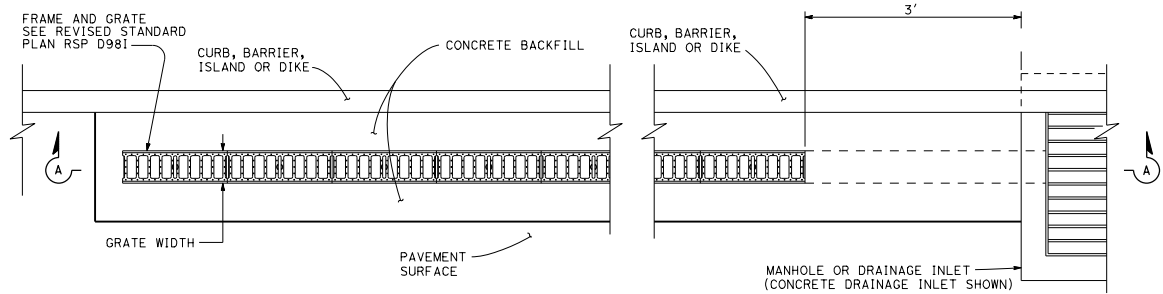

GRADED LINE DRAIN PLAN

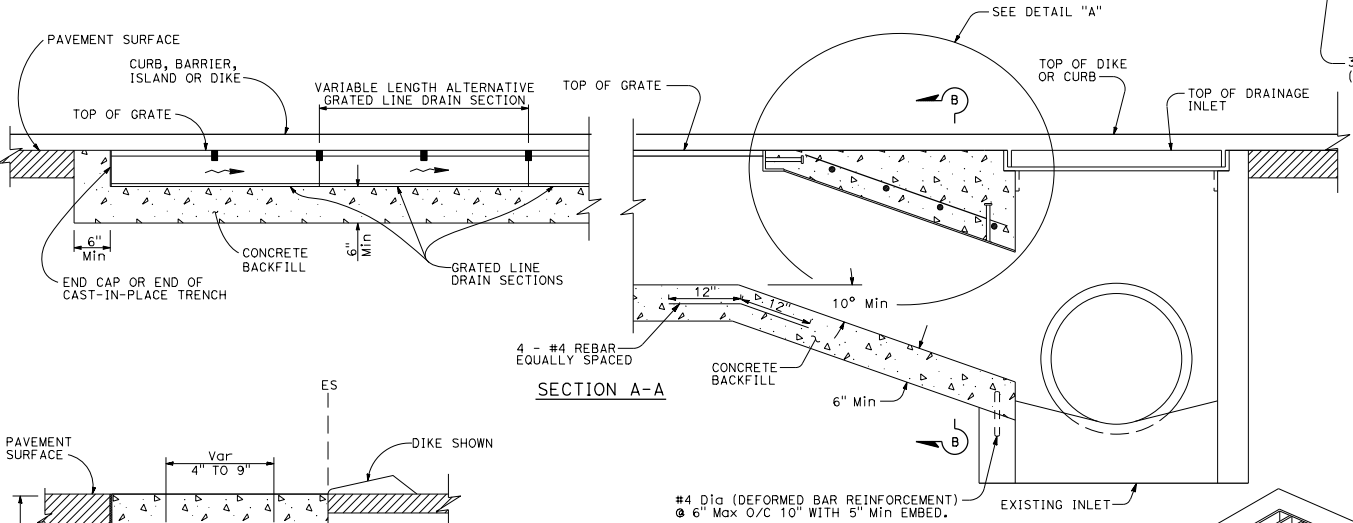

SECTION A-A

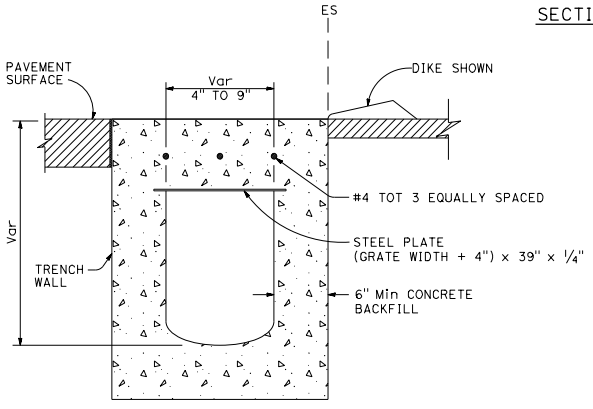

SECTION B-B

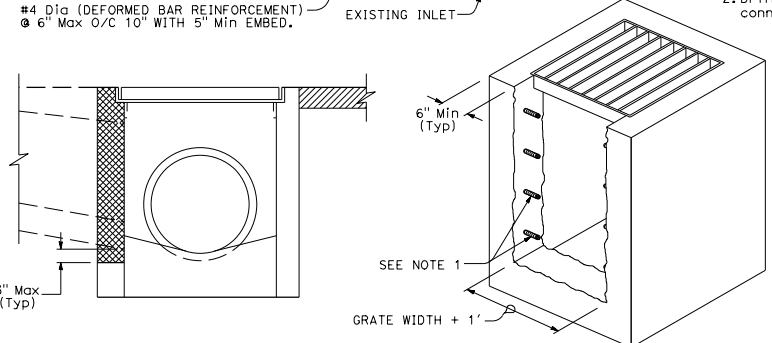

PARTIAL REMOVAL OF EXISTING DROP INLET

LEGEND:

- Pavement
- Limits of Removal

- NOTES:**
1. Preserve existing rebar during removal of side wall to tie to trench drain reinforcement. Install additional rebar to facilitate connection to drop inlet and replace damaged existing rebar. Doweling perpendicular to side wall in lieu of connecting to existing rebar is not permitted.
 2. Drill rebar ends 3" into existing concrete, overlap and connect with double barrel mechanical coupler.

STATE OF CALIFORNIA
 DEPARTMENT OF TRANSPORTATION
**GRADED LINE DRAIN
 DETAILS No. 4 - CONNECTION
 TO EXISTING DRAINAGE
 STRUCTURE**
 NO SCALE

RSP D98J DATED JANUARY 20, 2017 SUPPLEMENTS THE STANDARD PLANS BOOK DATED 2015.

REVISED STANDARD PLAN RSP D98J

2015 REVISED STANDARD PLAN RSP D98J

DIST	COUNTY	ROUTE	POST MILES TOTAL PROJECT	SHEET TOTAL NO. SHEETS

 REGISTERED ELECTRICAL ENGINEER
 Hamid Zolfaghar
 No. E15636
 Exp. 12-31-19
 ELECTRICAL
 STATE OF CALIFORNIA

April 20, 2018
 PLANS APPROVAL DATE
THE STATE OF CALIFORNIA OR ITS OFFICERS OR AGENTS SHALL NOT BE RESPONSIBLE FOR THE ACCURACY OR COMPLETENESS OF SCANNED COPIES OF THIS PLAN SHEET.

LEGEND:

- AB** ABANDON. IF APPLIED TO CONDUIT, REMOVE CONDUCTORS
- BC** INSTALL PULL BOX IN EXISTING CONDUIT RUN
- BP** PEDESTRIAN BARRICADE, TYPE AS INDICATED ON PLAN
- CB** INSTALL CONDUIT INTO EXISTING PULL BOX
- CC** CONNECT NEW AND EXISTING CONDUIT. REMOVE EXISTING CONDUCTORS AND INSTALL CONDUCTORS AS INDICATED
- CF** CONDUIT TO REMAIN FOR FUTURE USE. REMOVE CONDUCTORS. INSTALL PULL TAPE
- DH** DETECTOR HANDHOLE
- FA** FOUNDATION TO BE ABANDONED
- IS** INSTALL SIGN ON SIGNAL MAST ARM
- NS** NO SLIP BASE ON STANDARD
- PEC** PHOTOELECTRIC CONTROL
- PEU** PHOTOELECTRIC UNIT
- RC** EQUIPMENT OR MATERIAL TO BE REMOVED AND BECOME THE PROPERTY OF THE CONTRACTOR
- RE** REMOVE ELECTROLIER, FUSES AND BALLAST. TAPE ENDS OF CONDUCTORS
- RL** RELOCATE EQUIPMENT
- RR** REMOVE AND REUSE EQUIPMENT
- RS** REMOVE AND SALVAGE EQUIPMENT
- SC** SPLICE NEW TO EXISTING CONDUCTORS
- SD** SERVICE DISCONNECT
- TSP** TELEPHONE SERVICE POINT

STANDARD ELECTROLIER

NEW	EXISTING	STANDARD TYPE
		15
		15D
		15 STRUCTURE
		15D STRUCTURE
		21
		21D
		21 STRUCTURE
		21D STRUCTURE
		30
		31
		32

MISCELLANEOUS ELECTROLIERS

NEW	EXISTING	
		LUMINAIRE ON WOOD POLE
		NON-STANDARD ELECTROLIER (SEE PROJECT LEGEND)
		CITY ELECTROLIER
		ELECTROLIER FOUNDATION (FUTURE INSTALLATION)

NOTES:

1. LED luminaires shall be Roadway 2 when installed on Type 21, 21D, 30, 31 and 32 Standards, unless otherwise specified. LED luminaires shall be Roadway 1 when installed on other type standards or poles, unless otherwise specified.

SOFFIT AND WALL-MOUNTED LUMINAIRES

- PENDANT SOFFIT LUMINAIRE, 70 W HPS UNLESS OTHERWISE SPECIFIED
- FLUSH-MOUNTED SOFFIT LUMINAIRE, 70 W HPS UNLESS OTHERWISE SPECIFIED
- WALL-MOUNTED LUMINAIRE, 70 W HPS UNLESS OTHERWISE SPECIFIED
- EXISTING SOFFIT OR WALL-MOUNTED LUMINAIRE TO REMAIN UNMODIFIED
- EXISTING SOFFIT OR WALL-MOUNTED LUMINAIRE TO BE MODIFIED AS SPECIFIED

NOTE:

Arrow indicates "street side" of luminaire.

STATE OF CALIFORNIA
DEPARTMENT OF TRANSPORTATION

**ELECTRICAL SYSTEMS
(LEGEND)**

NO SCALE

RSP ES-1A DATED APRIL 20, 2018 SUPERSEDES RSP ES-1A DATED JULY 21, 2017 AND STANDARD PLAN ES-1A DATED OCTOBER 30, 2015 - PAGE 418 OF THE STANDARD PLANS BOOK DATED 2015.

REVISED STANDARD PLAN RSP ES-1A



2015 REVISED STANDARD PLAN RSP ES-1A

DIST	COUNTY	ROUTE	POST MILES TOTAL PROJECT	SHEET NO.	TOTAL SHEETS











 REGISTERED ELECTRICAL ENGINEER
 July 21, 2017
 PLANS APPROVAL DATE
 No. E15636
 Exp. 12-31-17
 THE STATE OF CALIFORNIA OR ITS OFFICERS OR AGENTS SHALL NOT BE RESPONSIBLE FOR THE ACCURACY OR COMPLETENESS OF SCANNED COPIES OF THIS PLAN SHEET.

TO ACCOMPANY PLANS DATED _____

CONDUIT

NEW	EXISTING	
---	---	LIGHTING CONDUIT, UNLESS OTHERWISE INDICATED OR NOTED
---	---	TRAFFIC SIGNAL CONDUIT
---C---	---c---	COMMUNICATION CONDUIT
---T---	---t---	TELEPHONE CONDUIT
---F---	---f---	FIRE ALARM CONDUIT
---FO---	---fo---	FIBER OPTIC CONDUIT
---	---	CONDUIT TERMINATION
		CONDUIT RISER ATTACHED TO THE STRUCTURE OR SERVICE POLE







SERVICE EQUIPMENT

NEW	EXISTING	
---OH---	---oh---	OVERHEAD LINES
		WOOD POLE, "U" INDICATES UTILITY OWNED
		POLE GUY WITH ANCHOR
		UTILITY TRANSFORMER - GROUND MOUNTED
		SERVICE EQUIPMENT ENCLOSURE TYPE. DOOR INDICATES FRONT OF ENCLOSURE
		TELEPHONE DEMARCATION CABINET































POLE-MOUNTED SERVICE DESIGNATION

	TYPE H SERVICE, 28'-10"	TYPE OF INSTALLATION AND POLE HEIGHT ABOVE GRADE
---	-------------------------	--







FLASHING BEACON

NEW	EXISTING	
		FLASHING BEACON (ONE VEHICLE SIGNAL HEAD WITH BACKPLATE AND VISOR) "R" INDICATES RED INDICATION, "Y" INDICATES YELLOW INDICATION
		FLASHING BEACON WITH TYPE 15-FBS STANDARD AND A SIGN.
		FLASHING BEACON WITH TYPES 9, 9A OR 9B SIGN UNLESS OTHERWISE SPECIFIED OR INDICATED

SIGNAL EQUIPMENT

NEW	EXISTING	
		PEDESTRIAN SIGNAL HEAD
		PUSH BUTTON ASSEMBLY POST
		PEDESTRIAN BARRICADE
		VEHICLE SIGNAL HEAD (WITH BACKPLATE)
		VEHICLE SIGNAL HEAD WITH ANGLE VISOR
		MODIFICATIONS OF BASIC SYMBOL: "L" INDICATES ALL NON-ARROW SECTIONS LOUVERED "LG" INDICATES LOUVERED GREEN SECTION ONLY "PV" INDICATES ALL 12" SECTIONS PROGRAMMED VISIBILITY "8" INDICATES ALL 8" SECTIONS (ONLY WHEN SPECIFIED)
		VEHICLE SIGNAL HEAD CONSISTING OF RED, YELLOW AND GREEN LEFT ARROW SECTIONS
		VEHICLE SIGNAL HEAD CONSISTING OF RED AND YELLOW SECTIONS WITH AN UP GREEN ARROW SECTION
		VEHICLE SIGNAL HEAD (5 SECTION) CONSISTING OF RED, YELLOW AND GREEN SECTIONS WITH YELLOW AND GREEN RIGHT ARROW SECTIONS
		TYPE 15TS STANDARD WITH VEHICLE SIGNAL HEAD AND LUMINAIRE
		TYPE 21TS STANDARD WITH VEHICLE SIGNAL HEAD AND LUMINAIRE
		STANDARD WITH LUMINAIRE AND SIGNAL MAST ARMS AND ATTACHED VEHICLE SIGNAL HEADS
		TYPE 1 STANDARD WITH ATTACHED VEHICLE SIGNAL HEADS
		STANDARD WITH A SIGNAL MAST ARM, ATTACHED VEHICLE SIGNAL HEADS AND INTERNALLY ILLUMINATED STREET NAME SIGN
		CONTROLLER ASSEMBLY. DOOR INDICATES FRONT OF CABINET













SIGNAL EQUIPMENT Cont

NEW	EXISTING	
		GUARD POST
		TYPE 1 STANDARD WITH RAMP METERING SIGN
		OPTICAL DETECTOR FOR THE EMERGENCY VEHICLE DETECTION

NOTES:

- All signal sections shall be 12" unless shown otherwise.
- Signal heads shall be provided with backplates unless shown otherwise.

ILLUMINATED OVERHEAD SIGN

NEW	EXISTING	
		SINGLE POST, SINGLE ILLUMINATED SIGN, BALANCED BUTTERFLY
		SINGLE POST, DOUBLE ILLUMINATED SIGN, BALANCED BUTTERFLY
		SINGLE POST, SINGLE ILLUMINATED SIGN, FULL CANTILEVER
		DOUBLE POST, SINGLE ILLUMINATED SIGN
		SINGLE ILLUMINATED SIGN MOUNTED ON STRUCTURE
		DOUBLE POST, SINGLE ILLUMINATED SIGN WITH ELECTROLIER

STATE OF CALIFORNIA
DEPARTMENT OF TRANSPORTATION
**ELECTRICAL SYSTEMS
(LEGEND)**
NO SCALE

RSP ES-1B DATED JULY 21, 2017 SUPERSEDES STANDARD PLAN ES-1B DATED OCTOBER 30, 2015 - PAGE 419 OF THE STANDARD PLANS BOOK DATED 2015.

REVISED STANDARD PLAN RSP ES-1B

2015 REVISED STANDARD PLAN RSP ES-1B

DIST	COUNTY	ROUTE	POST MILES TOTAL PROJECT	SHEET TOTAL SHEETS

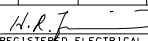
 REGISTERED ELECTRICAL ENGINEER
 No. E15636
 Exp. 12-31-17
 STATE OF CALIFORNIA

July 21, 2017
 PLANS APPROVAL DATE
 THE STATE OF CALIFORNIA OR ITS OFFICERS OR AGENTS SHALL NOT BE RESPONSIBLE FOR THE ACCURACY OR COMPLETENESS OF SCANNED COPIES OF THIS PLAN SHEET.

EQUIPMENT IDENTIFICATION

ILLUMINATED SIGN IDENTIFICATION:

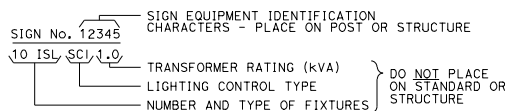

ELECTROLIER OR EQUIPMENT IDENTIFICATION:

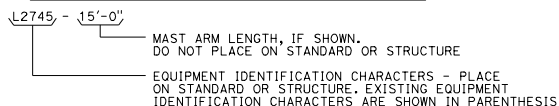

CONDUIT AND CONDUCTOR IDENTIFICATION:

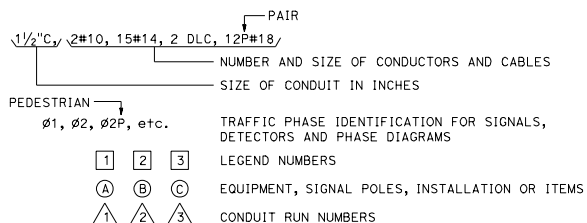

SIGNAL AND LIGHTING STANDARD (TYPICAL DESIGNATION):

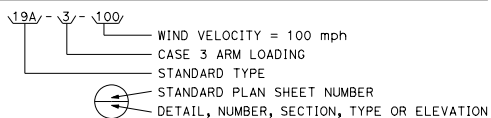

MISCELLANEOUS EQUIPMENT

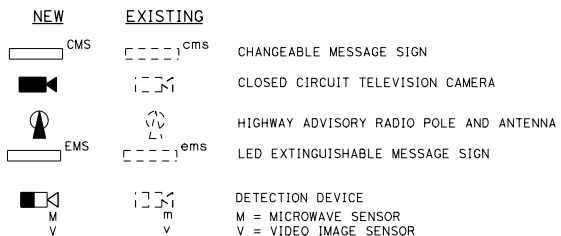

WIRING DIAGRAM LEGEND

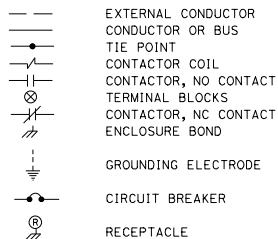

PULL BOXES

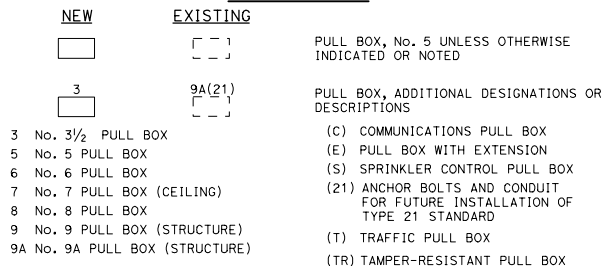

VEHICLE DETECTOR DESIGNATION

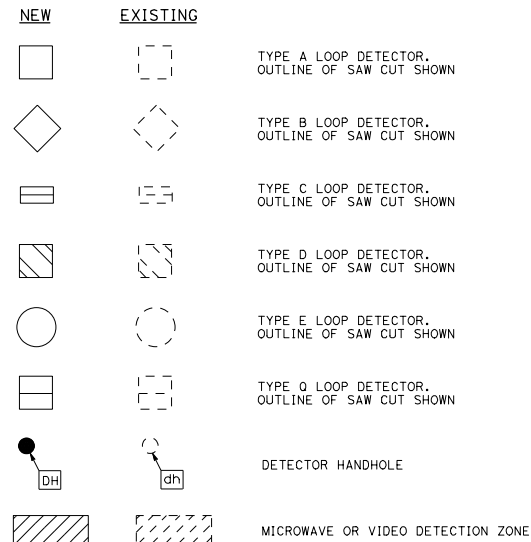
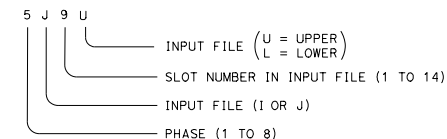

STATE OF CALIFORNIA
DEPARTMENT OF TRANSPORTATION

ELECTRICAL SYSTEMS (LEGEND AND ABBREVIATIONS)

NO SCALE

RSP ES-1C DATED JULY 21, 2017 SUPERSEDES RSP ES-1C DATED APRIL 15, 2016 AND STANDARD PLAN ES-1C DATED OCTOBER 30, 2015 - PAGE 420 OF THE STANDARD PLANS BOOK DATED 2015.

REVISED STANDARD PLAN RSP ES-1C

2015 REVISED STANDARD PLAN RSP ES-1C

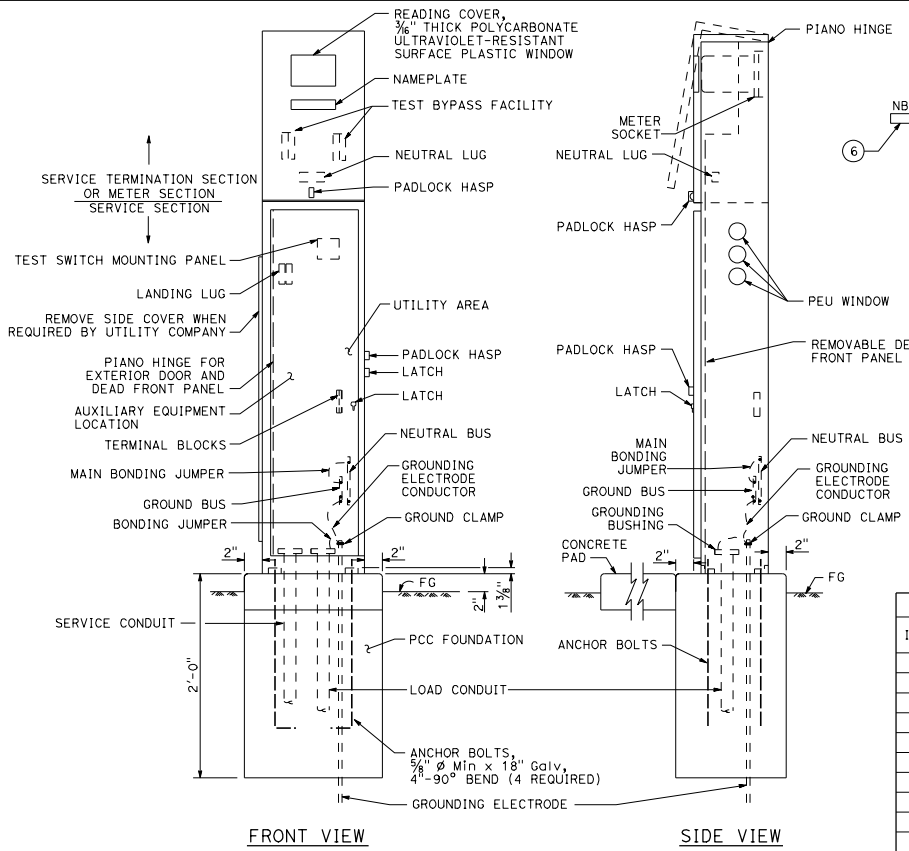

TYPE III-AF SERVICE EQUIPMENT ENCLOSURE (TYPICAL)
DETAIL A

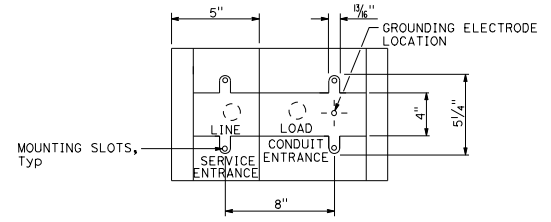

BASE FOR TYPE III-A SERVICE EQUIPMENT ENCLOSURE
DETAIL B

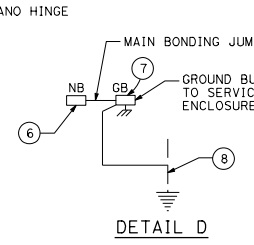

DETAIL D

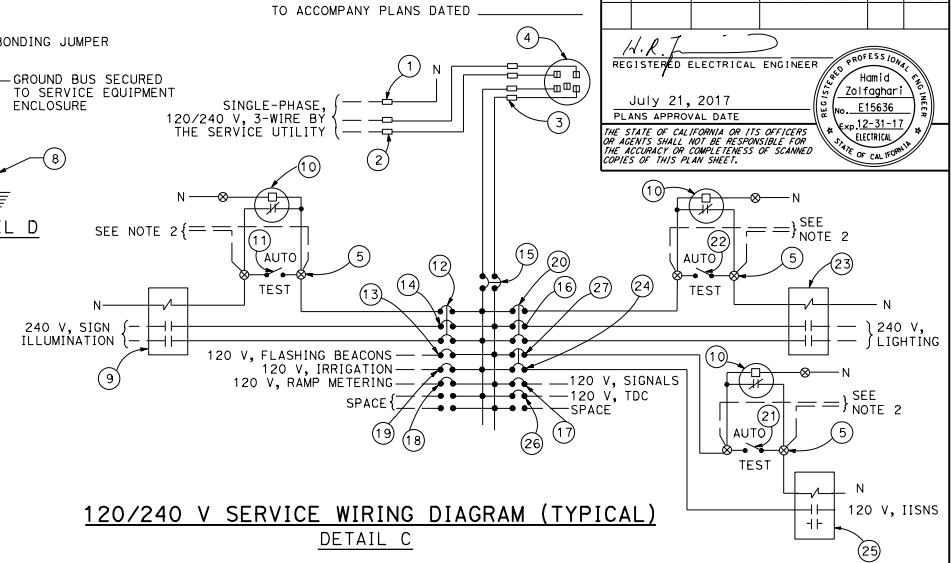

120/240 V SERVICE WIRING DIAGRAM (TYPICAL)
DETAIL C

TYPE III-A SERVICE EQUIPMENT ENCLOSURE LEGEND (120/240 V)					
ITEM	COMPONENT	NAMEPLATE DESCRIPTION	ITEM	COMPONENT	NAMEPLATE DESCRIPTION
①	NEUTRAL LUG		⑭	30 A, 240 V, 2P, CB	SIGN ILLUMINATION
②	LANDING LUG		⑮	100 A, 240 V, 2P, CB	MAIN BREAKER
③	TEST BYPASS FACILITY		⑯	30 A, 240 V, 2P, CB	LIGHTING
④	METER SOCKET AND SUPPORT		⑰	50 A, 120 V, 1P, CB	SIGNALS
⑤	TERMINAL BLOCKS		⑱	30 A, 120 V, 1P, CB	RAMP METERING
⑥	NEUTRAL BUS		⑲	20 A, 120 V, 1P, CB	IRRIGATION
⑦	GROUND BUS		⑳	15 A, 120 V, 1P, CB	LIGHTING CONTROL
⑧	GROUNDING ELECTRODE		㉑	15 A, 1P, TEST SWITCH	IISNS TEST SWITCH
⑨	30 A, 2P, NO CONTACTOR	SIGN ILLUMINATION	㉒	15 A, 1P, TEST SWITCH	LIGHTING TEST SWITCH
⑩	PHOTOELECTRIC UNIT (NOTE 4)	PEU	㉓	60 A, 2P, NO CONTACTOR	LIGHTING
⑪	15 A, 1P, TEST SWITCH	SIGN ILLUMINATION TEST SWITCH	㉔	15 A, 120 V, 1P, CB	IISNS
⑫	15 A, 120 V, 1P, CB	SIGN ILLUMINATION CONTROL	㉕	30 A, 2P, NO CONTACTOR	IISNS
⑬	15 A, 120 V, 1P, CB	FLASHING BEACON	㉖	20 A, 120 V, 1P, CB	TELEPHONE DEMARCATION CABINET
			㉗	15 A, 120 V, 1P, CB	IISNS CONTROL

NOTES:

- Unless otherwise indicated on the plans, service equipment items shall be provided for each service equipment enclosure as shown.
- Connect to remote test switch mounted on lighting standards, sign post or structure when required.
- Items ① and ⑥ shall be isolated from the service equipment enclosure.
- Type I photoelectric control shall be used unless otherwise indicated on the plans.
- Item ⑫, ⑲ and ⑳ shall be ganged operated CB.

STATE OF CALIFORNIA
DEPARTMENT OF TRANSPORTATION
ELECTRICAL SYSTEMS
(SERVICE EQUIPMENT ENCLOSURE
AND TYPICAL WIRING DIAGRAM,
TYPE III-A SERIES)

NO SCALE

RSP ES-20 DATED JULY 21, 2017 SUPERSEDES STANDARD PLAN ES-20
DATED OCTOBER 30, 2015 - PAGE 424 OF THE STANDARD PLANS BOOK DATED 2015.
REVISED STANDARD PLAN RSP ES-20

DIST	COUNTY	ROUTE	POST MILES TOTAL PROJECT	SHEET NO.	TOTAL SHEETS

REGISTERED ELECTRICAL ENGINEER
Hamid Zolfaghari
No. E15636
Exp. 12-31-17
STATE OF CALIFORNIA

PLANS APPROVAL DATE
July 21, 2017

THE STATE OF CALIFORNIA OR ITS OFFICERS OR AGENTS SHALL NOT BE RESPONSIBLE FOR THE ACCURACY OR COMPLETENESS OF SCANNED COPIES OF THIS PLAN SHEET.

2015 REVISED STANDARD PLAN RSP ES-20

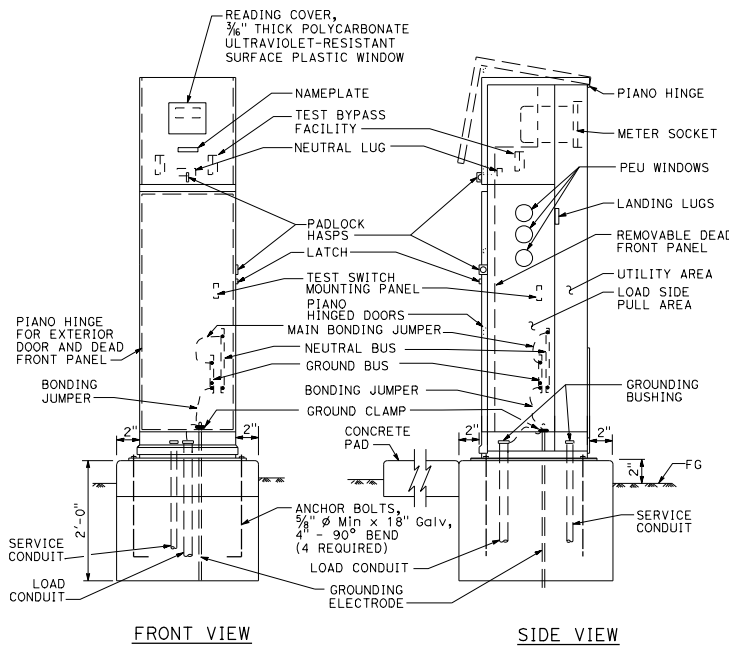

TYPE III-BF SERVICE EQUIPMENT ENCLOSURE (TYPICAL)

DETAIL A

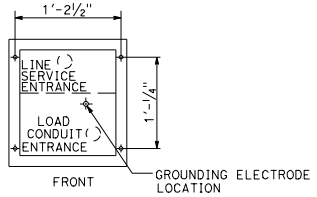

BASE FOR TYPE III-B SERVICE EQUIPMENT ENCLOSURE

DETAIL B

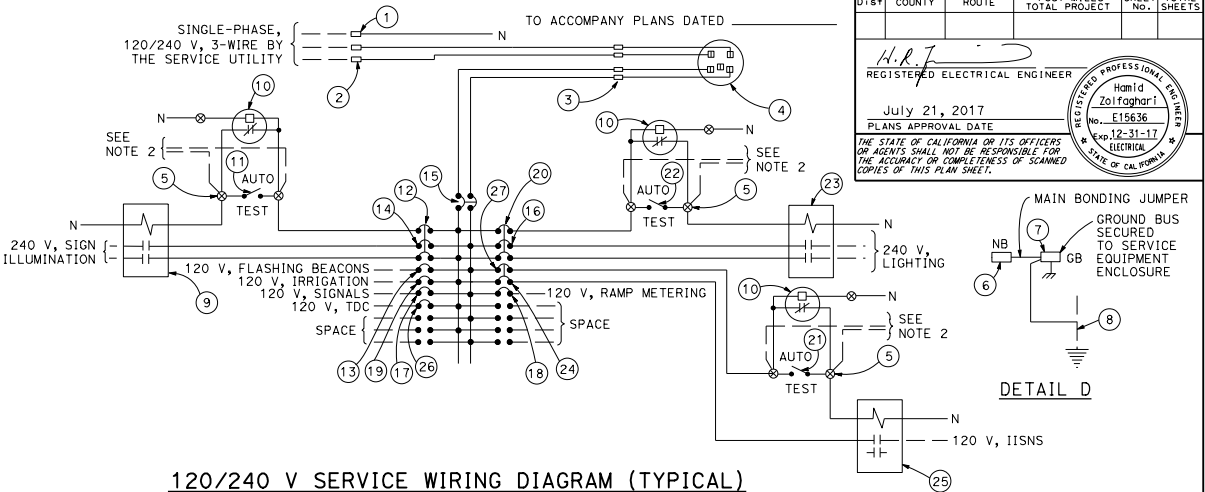

120/240 V SERVICE WIRING DIAGRAM (TYPICAL)

DETAIL C

TYPE III-B SERVICE EQUIPMENT ENCLOSURE LEGEND (120/240 V)					
ITEM	COMPONENT	NAMEPLATE DESCRIPTION	ITEM	COMPONENT	NAMEPLATE DESCRIPTION
①	NEUTRAL LUG		⑭	30 A, 240 V, 2P, CB	SIGN ILLUMINATION
②	LANDING LUG		⑮	100 A, 240 V, 2P, CB	MAIN BREAKER
③	TEST BYPASS FACILITY		⑯	30 A, 240 V, 2P, CB	LIGHTING
④	METER SOCKET AND SUPPORT		⑰	50 A, 120 V, 1P, CB	SIGNALS
⑤	TERMINAL BLOCKS		⑱	30 A, 120 V, 1P, CB	RAMP METERING
⑥	NEUTRAL BUS		⑲	20 A, 120 V, 1P, CB	IRRIGATION
⑦	GROUND BUS		⑳	15 A, 120 V, 1P, CB	LIGHTING CONTROL
⑧	GROUNDING ELECTRODE		㉑	15 A, 1P, TEST SWITCH	IISNS TEST SWITCH
⑨	30 A, 2P, NO CONTACTOR	SIGN ILLUMINATION	㉒	15 A, 1P, TEST SWITCH	LIGHTING TEST SWITCH
⑩	PHOTOELECTRIC UNIT (NOTE 4)	PEU	㉓	60 A, 2P, NO CONTACTOR	LIGHTING
⑪	15 A, 1P, TEST SWITCH	SIGN ILLUMINATION TEST SWITCH	㉔	15 A, 120 V, 1P, CB	IISNS
⑫	15 A, 120 V, 1P, CB	SIGN ILLUMINATION CONTROL	㉕	30 A, 2P, NO CONTACTOR	IISNS
⑬	15 A, 120 V, 1P, CB	FLASHING BEACON	㉖	20 A, 120 V, 1P, CB	TELEPHONE DEMARCATION CABINET
			㉗	15 A, 120 V, 1P, CB	IISNS CONTROL

NOTES:

- Unless otherwise indicated on the plans, service equipment items shall be provided for each service equipment enclosure as shown.
- Connect to remote test switch mounted on lighting standards, sign post or structure when required.
- Items ① and ⑥ shall be isolated from the service equipment enclosure.
- Type I photoelectric control shall be used unless otherwise indicated on the plans.
- Item ⑫, ⑲ and ㉗ shall be ganged operated CB.

DIST	COUNTY	ROUTE	POST MILES TOTAL PROJECT	SHEET TOTAL SHEETS

REGISTERED ELECTRICAL ENGINEER
Hamid Zolfaghar
No. E15636
Exp. 12-31-17
ELECTRICAL
STATE OF CALIFORNIA

PLANS APPROVAL DATE
July 21, 2017

THE STATE OF CALIFORNIA OR ITS OFFICERS OR AGENTS SHALL NOT BE RESPONSIBLE FOR THE ACCURACY OR COMPLETENESS OF SCANNED COPIES OF THIS PLAN SHEET.

STATE OF CALIFORNIA
DEPARTMENT OF TRANSPORTATION
**ELECTRICAL SYSTEMS
(SERVICE EQUIPMENT ENCLOSURE AND
TYPICAL WIRING DIAGRAM,
TYPE III-B SERIES)**

NO SCALE

RSP ES-2E DATED JULY 21, 2017 SUPERSEDES STANDARD PLAN ES-2E
DATED OCTOBER 30, 2015 - PAGE 425 OF THE STANDARD PLANS BOOK DATED 2015.

REVISED STANDARD PLAN RSP ES-2E

2015 REVISED STANDARD PLAN RSP ES-2E

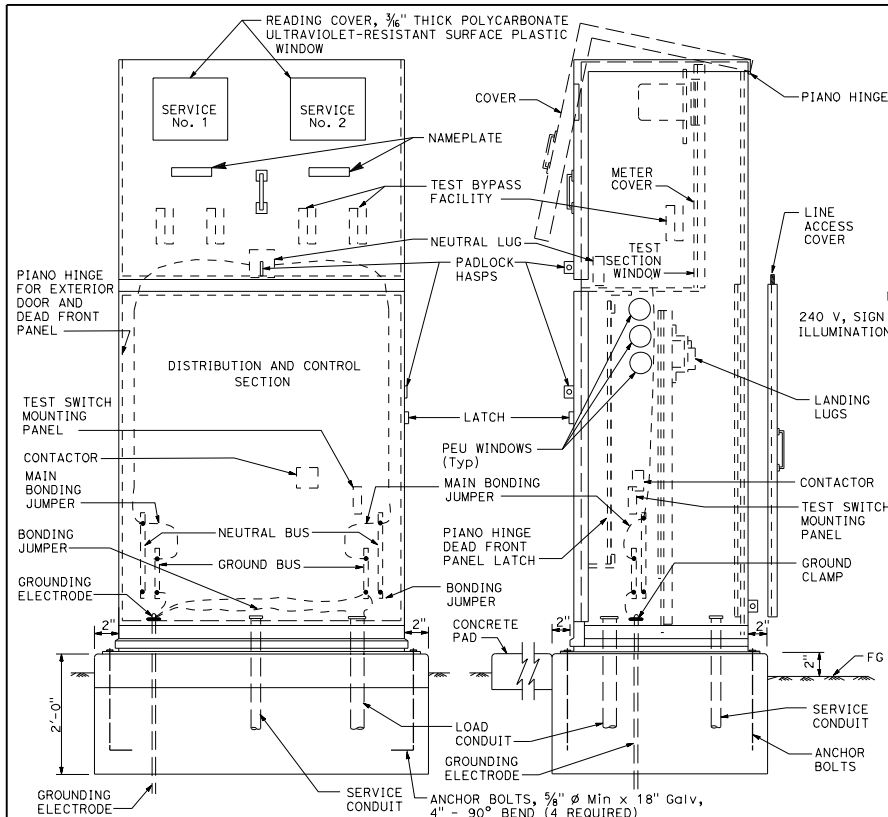

FRONT VIEW
SIDE VIEW
TYPE III-CF SERVICE EQUIPMENT ENCLOSURE (TYPICAL)
DETAIL A

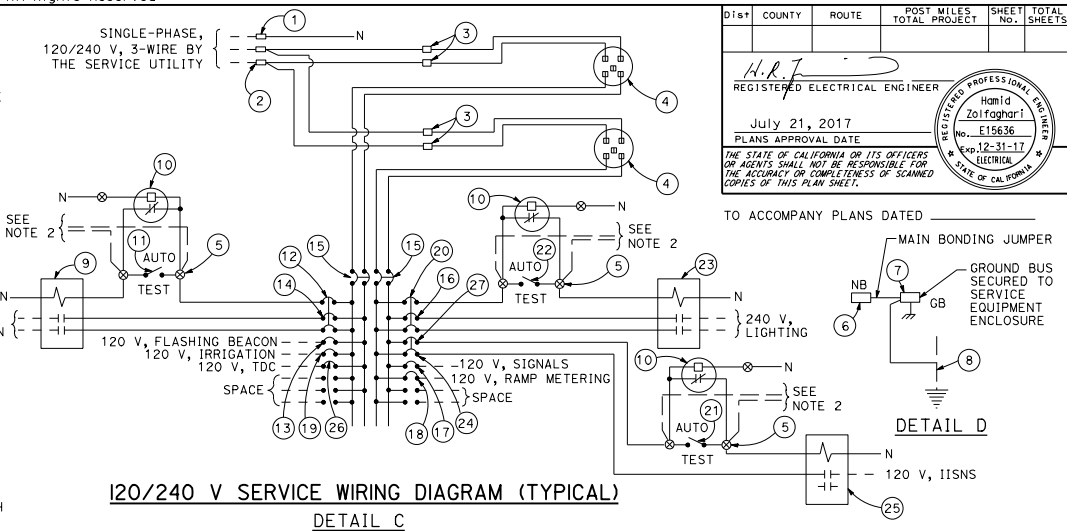

120/240 V SERVICE WIRING DIAGRAM (TYPICAL)
DETAIL C

TYPE III-C SERVICE EQUIPMENT ENCLOSURE LEGEND (120/240 V)					
ITEM	COMPONENT	NAMEPLATE DESCRIPTION	ITEM	COMPONENT	NAMEPLATE DESCRIPTION
1	NEUTRAL LUG		14	30 A, 240 V, 2P, CB	SIGN ILLUMINATION
2	LANDING LUG		15	100 A, 240 V, 2P, CB	MAIN BREAKER
3	TEST BYPASS FACILITY		16	30 A, 240 V, 2P, CB	LIGHTING
4	METER SOCKET AND SUPPORT		17	50 A, 120 V, 1P, CB	SIGNALS
5	TERMINAL BLOCKS		18	30 A, 120 V, 1P, CB	RAMP METERING
6	NEUTRAL BUS		19	20 A, 120 V, 1P, CB	IRRIGATION
7	GROUND BUS		20	15 A, 120 V, 1P, CB	LIGHTING CONTROL
8	GROUNDING ELECTRODE		21	15 A, 1P, TEST SWITCH	IISNS TEST SWITCH
9	30 A, 2P, NO CONTACTOR	SIGN ILLUMINATION	22	15 A, 1P, TEST SWITCH	LIGHTING TEST SWITCH
10	PHOTOELECTRIC UNIT (NOTE 4)	PEU	23	60 A, 2P, NO CONTACTOR	LIGHTING
11	15 A, 1P, TEST SWITCH	SIGN ILLUMINATION TEST SWITCH	24	15 A, 120 V, 1P, CB	IISNS
12	15 A, 120 V, 1P, CB	SIGN ILLUMINATION CONTROL	25	30 A, 2P, NO CONTACTOR	IISNS
13	15 A, 120 V, 1P, CB	FLASHING BEACON	26	20 A, 120 V, 1P, CB	TELEPHONE DEMARCATION CABINET
			27	15 A, 120 V, 1P, CB	IISNS CONTROL

NOTES:

- Unless otherwise indicated on the plans, service equipment items shall be provided for each service equipment enclosure as shown.
- Connect to remote test switch mounted on lighting standards, sign post or structure when required.
- Items 1 and 6 shall be isolated from the service equipment enclosure.
- Type I photoelectric control shall be used unless otherwise indicated on the plans.
- Item 12, 20 and 27 shall be ganged operated CB.

DIST	COUNTY	ROUTE	POST MILES TOTAL PROJECT	SHEET TOTAL SHEETS

REGISTERED ELECTRICAL ENGINEER
Hamid Zolfaghar
No. E15636
Exp. 12-31-17
STATE OF CALIFORNIA

PLANS APPROVAL DATE
July 21, 2017

THE STATE OF CALIFORNIA OR ITS OFFICERS OR AGENTS SHALL NOT BE RESPONSIBLE FOR THE ACCURACY OR COMPLETENESS OF SCANNED COPIES OF THIS PLAN SHEET.

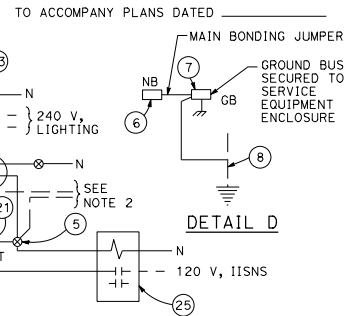

TO ACCOMPANY PLANS DATED _____

DETAIL D

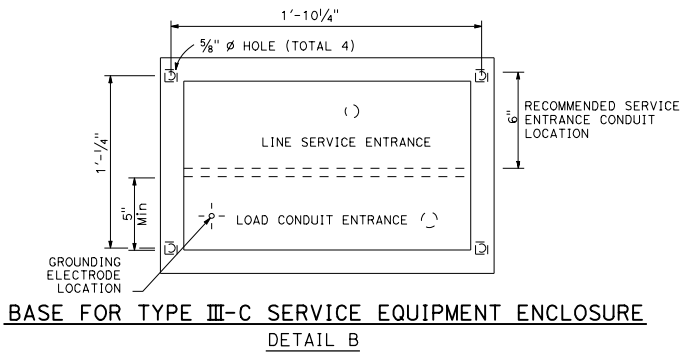

BASE FOR TYPE III-C SERVICE EQUIPMENT ENCLOSURE
DETAIL B

STATE OF CALIFORNIA
DEPARTMENT OF TRANSPORTATION
**ELECTRICAL SYSTEMS
(SERVICE EQUIPMENT ENCLOSURE AND
TYPICAL WIRING DIAGRAM,
TYPE III-C SERIES)**

NO SCALE

RSP ES-2F DATED JULY 21, 2017 SUPERSEDES STANDARD PLAN ES-2F
DATED OCTOBER 30, 2015 - PAGE 426 OF THE STANDARD PLANS BOOK DATED 2015.

REVISED STANDARD PLAN RSP ES-2F

2015 REVISED STANDARD PLAN RSP ES-2F

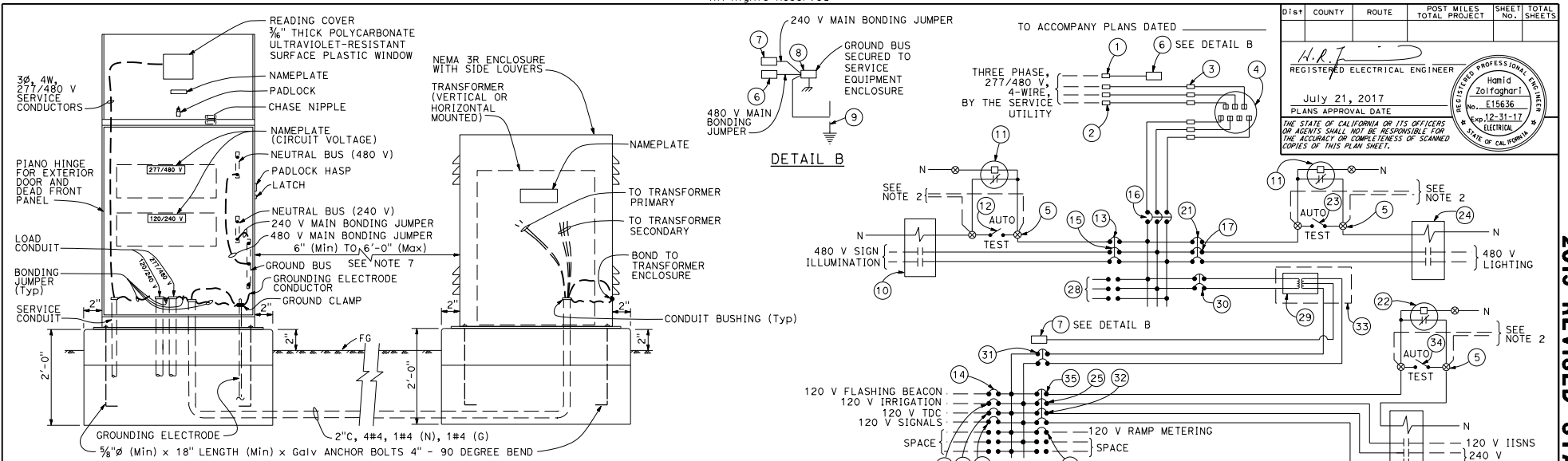

SIDE INSTALLATION OF TRANSFORMER

277/480 V SERVICE WIRING DIAGRAM (TYPICAL)

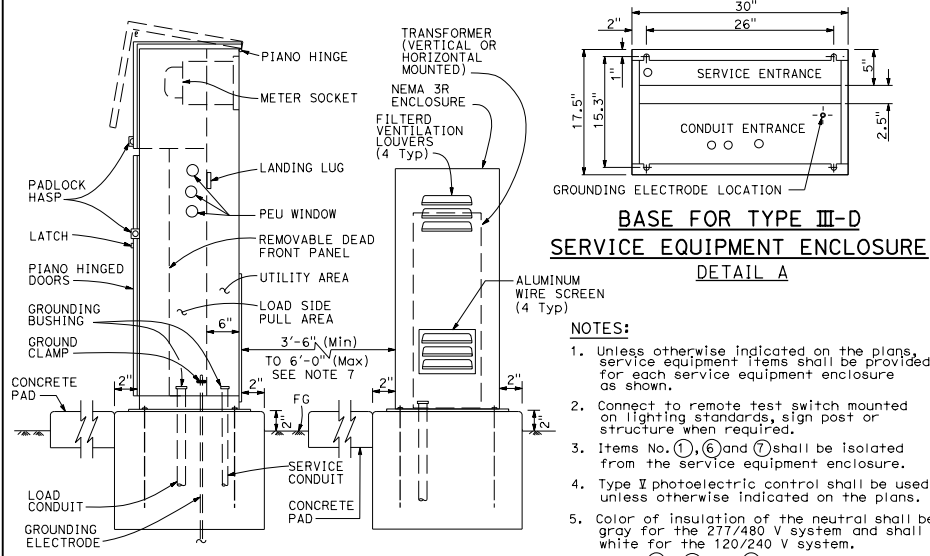

REAR INSTALLATION OF TRANSFORMER

BASE FOR TYPE III-D SERVICE EQUIPMENT ENCLOSURE
DETAIL A

- NOTES:
- Unless otherwise indicated on the plans, service equipment items shall be provided for each service equipment enclosure as shown.
 - Connect to remote test switch mounted on lighting standards, sign post or structure when required.
 - Items No. ①, ⑥ and ⑦ shall be isolated from the service equipment enclosure.
 - Type I photoelectric control shall be used unless otherwise indicated on the plans.
 - Color of insulation of the neutral shall be gray for the 277/480 V system and shall be white for the 120/240 V system.
 - Items ⑬, ⑰ and ⑲ shall be ganged operated CB.
 - The NEMA 3R enclosure shall be located to the side of the service equipment enclosure unless otherwise indicated on the plans.
 - The base dimension for the NEMA 3R enclosure for the transformer shall be as per manufacturer's design.

TYPE III-DF SERVICE EQUIPMENT ENCLOSURE
TYPICAL

TYPE III-D SERVICE (277/480 V) EQUIPMENT LEGEND					
ITEM No.	COMPONENT	NAMEPLATE DESCRIPTION	ITEM No.	COMPONENT	NAMEPLATE DESCRIPTION
①	NEUTRAL LUG		⑲	20 A, 120 V, 1P, CB	IRRIGATION (120 V)
②	LANDING LUG		⑳	10 A, 277 V, 1P, CB	LIGHTING CONTROL (277 V)
③	TEST BYPASS FACILITY		㉑	PHOTOELECTRIC UNIT (NOTE 4)	PEU (120/240 V)
④	METER SOCKET AND SUPPORT		㉒	15 A, 1P, TEST SWITCH	LIGHTING TEST SWITCH (277 V)
⑤	TERMINAL BLOCKS		㉓	30 A, 2P, NO CONTACTOR	LIGHTING (480 V)
⑥	NEUTRAL BUS	NEUTRAL BUS (480 V)	㉔	15 A, 120 V, 1P, CB	IISNS (120 V)
⑦	NEUTRAL BUS	NEUTRAL BUS (240 V)	㉕	30 A, 3P, NO CONTACTOR	INTERSECTION LIGHTING (120 V)
⑧	GROUND BUS		㉖	20 A, 120 V, 1P, CB	TELEPHONE DEMARCATION CABINET (120 V)
⑨	GROUNDING ELECTRODE		㉗	20 A, 480 V, 3P, CB	SPACE
⑩	30 A, 2P, NO CONTACTOR	SIGN ILLUMINATION (480 V)	㉘	15 kVA, 480-120/240 V TRANSFORMER	TRANSFORMER, 15 kVA, 480-240 V
⑪	PHOTOELECTRIC UNIT (NOTE 4)	PEU (277/480 V PEU)	㉙	40 A, 480 V, 2P, CB	TRANSFORMER PRIMARY (480 V)
⑫	15 A, 1P, TEST SWITCH	SIGN ILLUMINATION TEST SWITCH (277 V)	㉚	10 A, 277 V, 1P, CB	TRANSFORMER SECONDARY (240 V)
⑬	10 A, 277 V, 1P, CB	SIGN ILLUMINATION CONTROL (277 V)	㉛	30 A, 240 V, 2P, CB	INTERSECTION LIGHTING (240 V)
⑭	15 A, 120 V, 1P, CB	FLASHING BEACON (120 V)	㉜	30 A, 240 V, 2P, CB	INTERSECTION LIGHTING (240 V)
⑮	15 A, 480 V, 2P, CB	SIGN ILLUMINATION (480 V)	㉝	NEMA 3R ENCLOSURE WITH LOUVERS	TRANSFORMER, 15 kVA, 480-240 V
⑯	100 A, 480 V, 3P, CB	MAIN BREAKER (480 V)	㉞	15 A, 1P, TEST SWITCH	IISNS AND INTERSECTION LIGHTING TEST SWITCH (120 V)
⑰	15 A, 480 V, 2P, CB	LIGHTING (480 V)	㉟	10 A, 120 V, 1P, CB	IISNS AND INTERSECTION LIGHTING CONTROL (120 V)
⑱	50 A, 120 V, 1P, CB	SIGNAL (120 V)			
⑳	30 A, 120 V, 1P, CB	RAMP METERING (120 V)			

STATE OF CALIFORNIA
DEPARTMENT OF TRANSPORTATION
**ELECTRICAL SYSTEMS
(SERVICE EQUIPMENT ENCLOSURE
AND TYPICAL WIRING DIAGRAM,
TYPE III-D SERIES)**

RSP ES-2G DATED JULY 21, 2017 SUPERSEDES STANDARD PLAN ES-2G
DATED OCTOBER 30, 2015 - PAGE 427 OF THE STANDARD PLANS BOOK DATED 2015.

REVISED STANDARD PLAN RSP ES-2G

NO SCALE

2015 REVISED STANDARD PLAN RSP ES-2G

DIST.	COUNTY	ROUTE	POST MILES	SHEET TOTAL
			TOTAL PROJECT	SHEETS

REGISTERED ELECTRICAL ENGINEER
Hamid Zolfaghari
No. E15636
Exp. 12-31-17
ELECTRICAL ENGINEER
STATE OF CALIFORNIA

July 21, 2017
PLANS APPROVAL DATE

THE STATE OF CALIFORNIA OR ITS OFFICERS OR AGENTS SHALL NOT BE RESPONSIBLE FOR THE ACCURACY OR COMPLETENESS OF SCANNED COPIES OF THIS PLAN SHEET.

NOTES:

- Type G, M, P, R, S and Model 336L cabinets shall be installed with the back toward the nearest lane of traffic.
- In unpaved areas, a raised portland cement concrete pad shall be constructed in front of each controller cabinet. The pad shall be 3'-0" x 3'-0" x 4" for a Type G cabinet and shall be 3'-0" x 4" thick x width of foundation for Type M, P, R, S and Model 336L cabinets.
- The steel pedestal, base plate, and bolt circle for Type G cabinet shall be the same as that shown for a Type 1-C Standard (see Revised Standard Plan RSP ES-7B). Pedestal shall be 2'-1" to 2'-6" in length. Anchor bolts shall be 3/4" ϕ x 1'-6" with a 2" - 90° bend. Four bolts required per cabinet.
- Type G cabinet shall be provided with a slipfitter to permit mounting an 4/2" outside diameter pedestal. Slipfitter shall be bolted to bottom of the cabinet.
- A 1" drain shall be provided through the foundation of a Type M or Model 336L cabinet. Drain pipe shall be screened.
- Cabinet shelves shall be adjustable for vertical spacing and shall be removable. Type M, P, R and S cabinets shall be provided with a minimum of two shelves.
- Controller units, plug-mounted equipment, shelf-mounted equipment and wall-mounted equipment shall be located to permit safe and easy removal or replacement without removing any other piece of equipment.
- Where telephone interconnect is required, a minimum of 5" clear vertical space shall be provided inside the cabinet for the equipment.
- Telephone interconnect conductors shall be enclosed in a 3/4" C or larger conduit through the foundation. Type 4 conduit shall be used to separate telephone and power conductors in cabinets or pedestals.
- Anchor bolts for Type M, P, R, S and Model 336L cabinets shall be 3/4" ϕ x 1'-6" with a 2" - 90° bend.

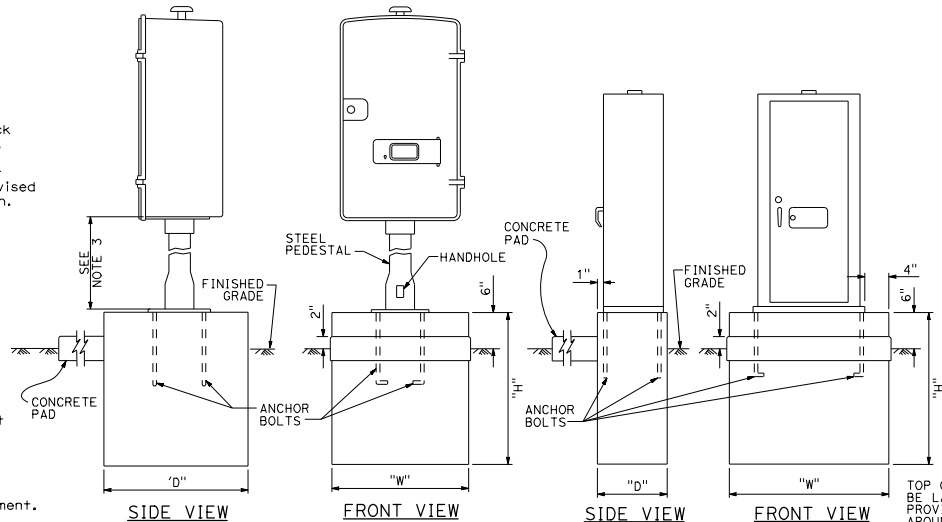

DIST	COUNTY	ROUTE	POST MILES TOTAL PROJECT	SHEET TOTAL SHEETS

REGISTERED ELECTRICAL ENGINEER
Hamid Zolfaghar
No. E15636
Exp. 12-31-19
STATE OF CALIFORNIA

APRIL 20, 2018
PLANS APPROVAL DATE
THE STATE OF CALIFORNIA OR ITS OFFICERS OR AGENTS SHALL NOT BE RESPONSIBLE FOR THE ACCURACY OR COMPLETENESS OF SCANNED COPIES OF THIS PLAN SHEET.

TO ACCOMPANY PLANS DATED _____

CABINET TYPE	FOUNDATION		
	"W"	"H"	"D"
G	2'-0"	3'-6"	2'-0"
M	3'-2"	2'-6"	1'-6"
P	4'-4 1/2"	1'-6"	2'-4"
R	4'-2"	1'-6"	2'-4"
S	5'-11 1/2"	1'-6"	2'-4"

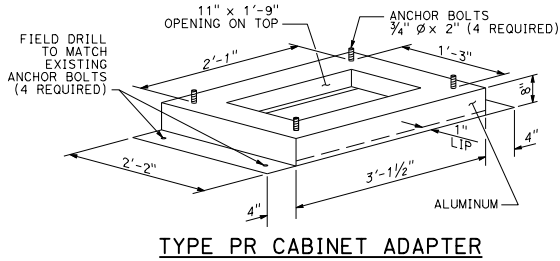
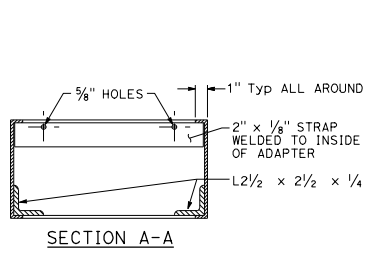
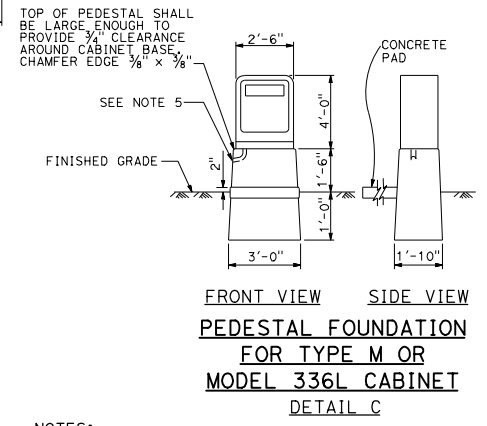

See Notes A and B

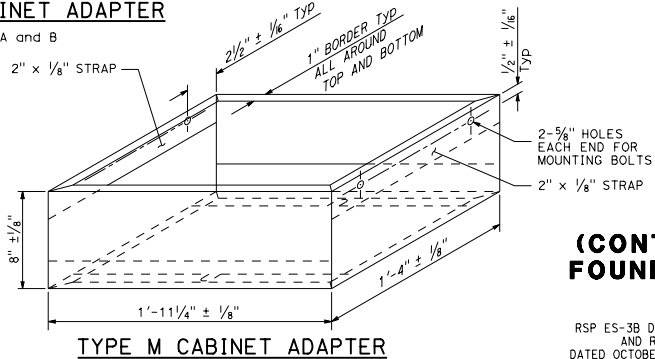

See Notes A, C, and D

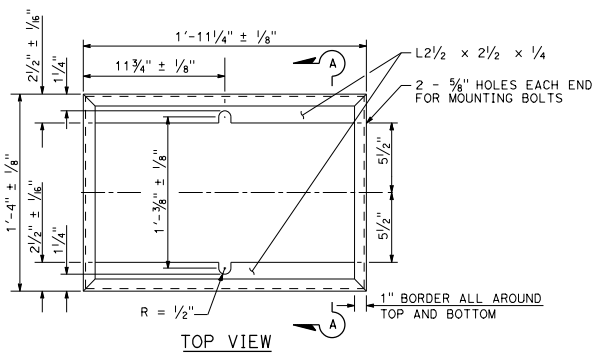

NOTES:

- Material: 0.188" thickness aluminum plate.
- Adapter for Type P or Type R cabinet foundation.
- Adapter for Type M cabinet foundation.
- Mounting bolts shall be 3/8" ϕ minimum size.

STATE OF CALIFORNIA
DEPARTMENT OF TRANSPORTATION
**ELECTRICAL SYSTEMS
(CONTROLLER CABINET ADAPTER,
FOUNDATIONS, AND PAD DETAILS)**
NO SCALE

RSP ES-3B DATED APRIL 20, 2018 SUPERSEDES RSP ES-3B DATED JULY 21, 2017
AND RSP ES-3B DATED APRIL 15, 2016 AND STANDARD PLAN ES-3B
DATED OCTOBER 30, 2015 - PAGE 429 OF THE STANDARD PLANS BOOK DATED 2015.

REVISED STANDARD PLAN RSP ES-3B

2015 REVISED STANDARD PLAN RSP ES-3B

NOTES:

1. Controller units, plug-mounted equipment, shelf-mounted equipment and wall-mounted equipment shall be located to permit safe and easy removal or replacement without removing any other piece of equipment.
2. Cabinet fan may be installed at an alternate location near the top of the cabinet when approved by the Engineer.
3. Where telephone interconnect is required, a minimum of 5" clear vertical space shall be provided inside the cabinet for the equipment.
4. Telephone interconnect conductors shall be enclosed in a 3/4" or larger conduit through the foundation. Type 4 conduit shall be used to separate telephone and power conductors in cabinets.

DIST	COUNTY	ROUTE	POST MILES TOTAL PROJECT	SHEET NO.	TOTAL SHEETS

Theresa Gabriel
 REGISTERED ELECTRICAL ENGINEER
 No. E15129
 Exp. 6-30-16
 STATE OF CALIFORNIA
 ELECTRICAL

April 15, 2016
 PLANS APPROVAL DATE
 THE STATE OF CALIFORNIA OR ITS OFFICERS OR AGENTS SHALL NOT BE RESPONSIBLE FOR THE ACCURACY OR COMPLETENESS OF SCANNED COPIES OF THIS PLAN SHEET.

TO ACCOMPANY PLANS DATED _____

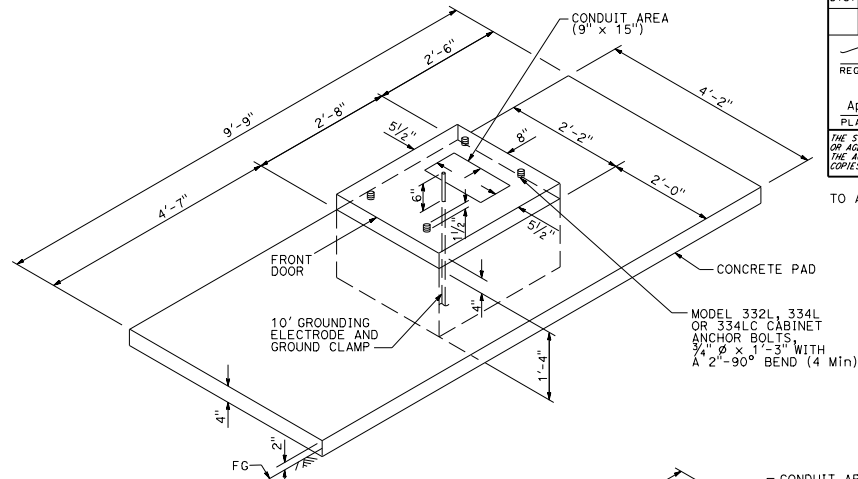

FOUNDATION AND PAD DETAIL

Model 332L, 334L and 334LC

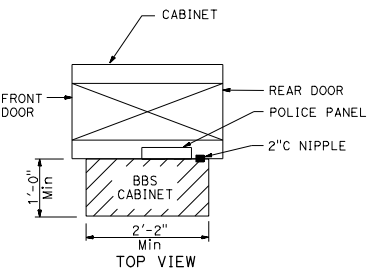

BASE PLAN FOR BBS MOUNTED TO THE MODEL 332L CABINET

(FOR DIMENSIONS AND DETAILS NOT SHOWN, SEE CABINET HOUSING DETAILS OF THE TRANSPORTATION ELECTRICAL EQUIPMENT SPECIFICATION (TEES))

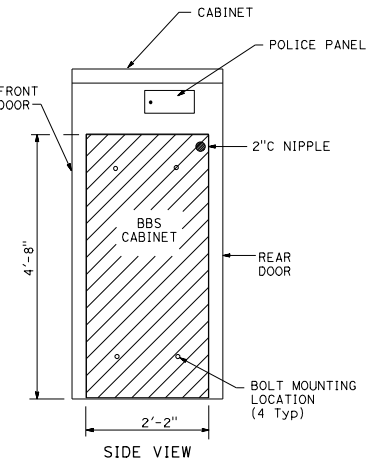

BBS CABINET MOUNTED TO THE MODEL 332L CABINET

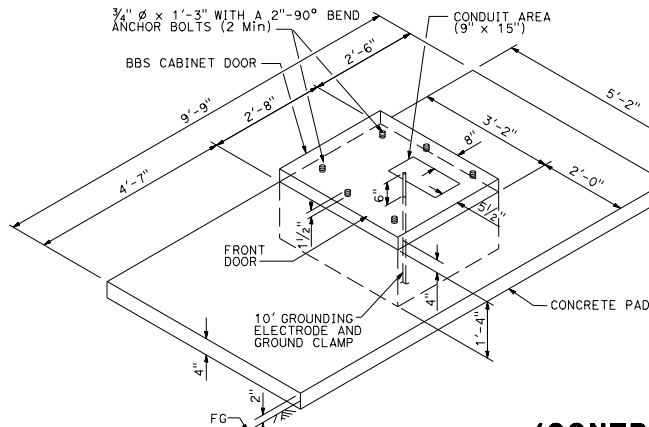

LEFT SIDE INSTALLATION

DETAIL A

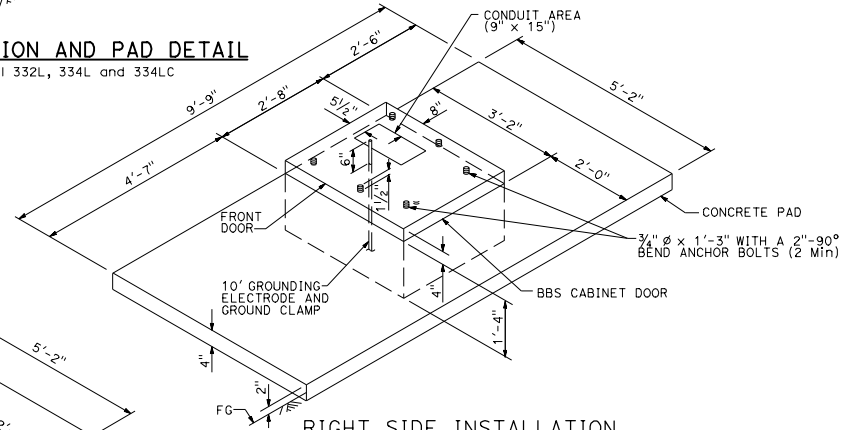

RIGHT SIDE INSTALLATION

DETAIL B

MODIFIED MODEL 332L CABINET FOUNDATION DETAIL FOR BATTERY BACKUP SYSTEM

STATE OF CALIFORNIA
DEPARTMENT OF TRANSPORTATION

ELECTRICAL SYSTEMS (CONTROLLER CABINET FOUNDATION AND PAD DETAILS)

NO SCALE

RSP ES-3C DATED APRIL 15, 2016 SUPERSEDES STANDARD PLAN ES-3C DATED OCTOBER 30, 2015 - PAGE 430 OF THE STANDARD PLANS BOOK DATED 2015.

REVISED STANDARD PLAN RSP ES-3C

2015 REVISED STANDARD PLAN RSP ES-3C

NOTES:

1. Controller units, plug-mounted equipment, shelf-mounted equipment and wall-mounted equipment shall be located to permit safe and easy removal or replacement without removing any other piece of equipment.
2. Cabinet fan may be installed at an alternate location near the top of the cabinet when approved by the Engineer.
3. Where telephone interconnect is required, a minimum of 5" clear vertical space shall be provided inside the cabinet for the equipment.
4. Telephone interconnect conductors shall be enclosed in a 3/4" or larger conduit through the foundation. Type 4 conduit shall be used to separate telephone and power conductors in cabinets.
5. Dimensions are nominal.
6. For Model 342LX, 344LX and 346LX cabinets details, see "Transportation Electrical Equipment Specifications".
7. Grounding electrode shall be placed 3 inches in front of the service conduit area.
8. Conduit area, to 120 V Service.
9. Conduit area for the controller side of cabinet.

DIST	COUNTY	ROUTE	POST MILES TOTAL PROJECT	SHEET NO.	TOTAL SHEETS

H.R.F.
 REGISTERED ELECTRICAL ENGINEER
 Hamid Zolfaghar
 No. E15636
 Exp. 12-31-17
 ELECTRICAL
 STATE OF CALIFORNIA

PLANS APPROVAL DATE: July 21, 2017

THE STATE OF CALIFORNIA OR ITS OFFICERS OR AGENTS SHALL NOT BE RESPONSIBLE FOR THE ACCURACY OR COMPLETENESS OF SCANNED COPIES OF THIS PLAN SHEET.

TO ACCOMPANY PLANS DATED _____

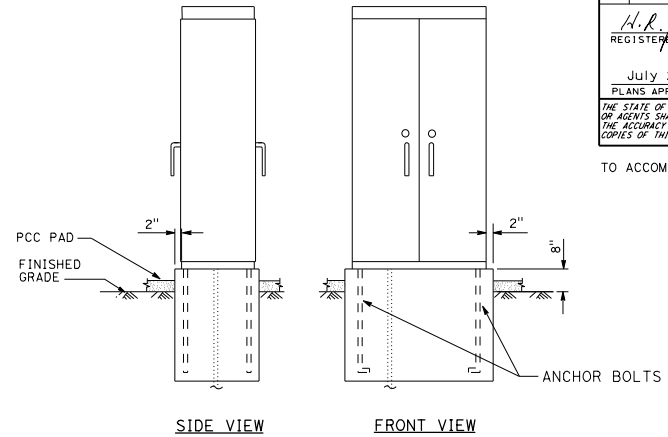

**FOUNDATION FOR TYPE LX CABINET
DETAIL A**

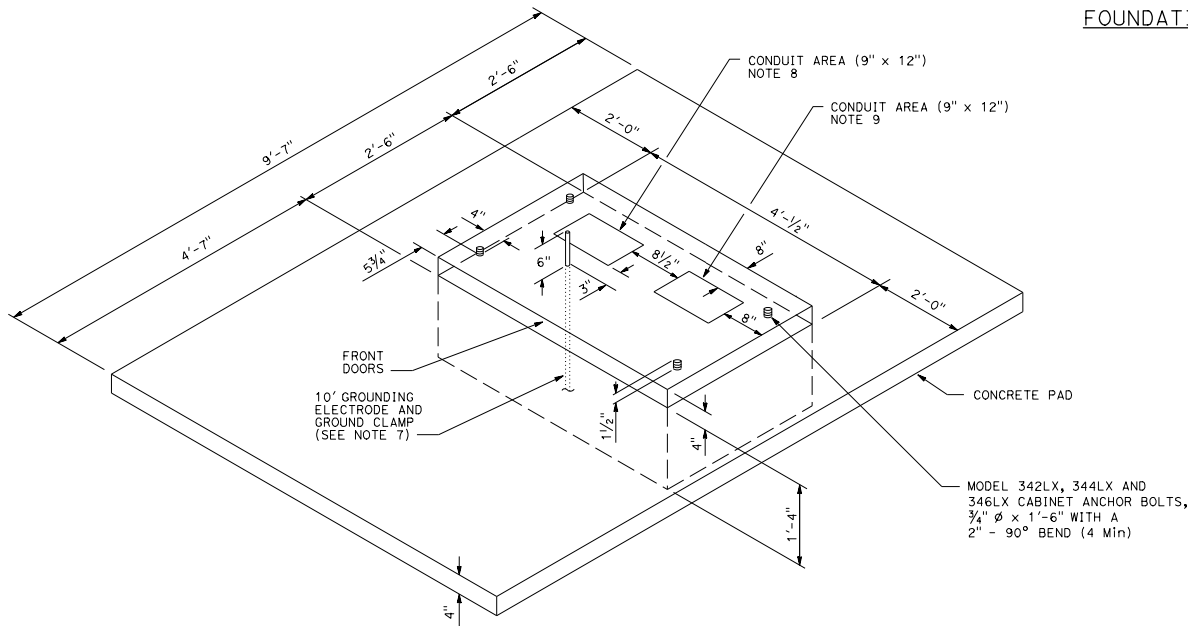

**FOUNDATION AND PAD DETAIL
Model 342LX, 344LX and 346LX
DETAIL B**

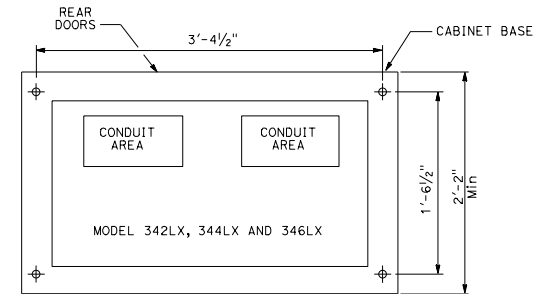

**BASE PLAN FOR THE MODEL
342LX, 344LX AND 346LX CABINET**

STATE OF CALIFORNIA
DEPARTMENT OF TRANSPORTATION
**ELECTRICAL SYSTEMS
(CONTROLLER CABINET
FOUNDATION AND PAD DETAILS)**
NO SCALE

RSP ES-3C1 DATED JULY 21, 2017 SUPPLEMENTS THE STANDARD PLANS BOOK DATED 2015.

REVISED STANDARD PLAN RSP ES-3C1

2015 REVISED STANDARD PLAN RSP ES-3C1

DIST	COUNTY	ROUTE	POST MILES TOTAL PROJECT	SHEET TOTAL SHEETS

H. R. J.
 REGISTERED ELECTRICAL ENGINEER
 Hamid Zolfghari
 No. E15636
 Exp. 12-31-17
 STATE OF CALIFORNIA
 ELECTRICAL

July 21, 2017
 PLANS APPROVAL DATE
 THE STATE OF CALIFORNIA OR ITS OFFICERS OR AGENTS SHALL NOT BE RESPONSIBLE FOR THE ACCURACY OR COMPLETENESS OF SCANNED COPIES OF THIS PLAN SHEET.

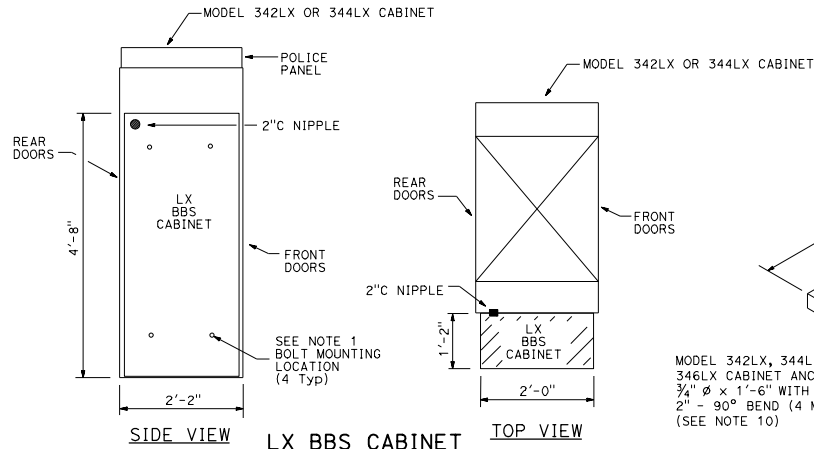

LX BBS CABINET MOUNTED TO THE MODEL 342LX OR 344LX CABINET

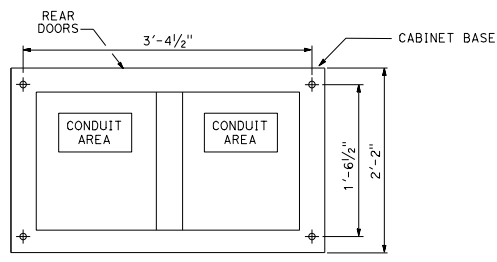

BASE PLAN FOR MODEL 342LX OR 344LX CABINET

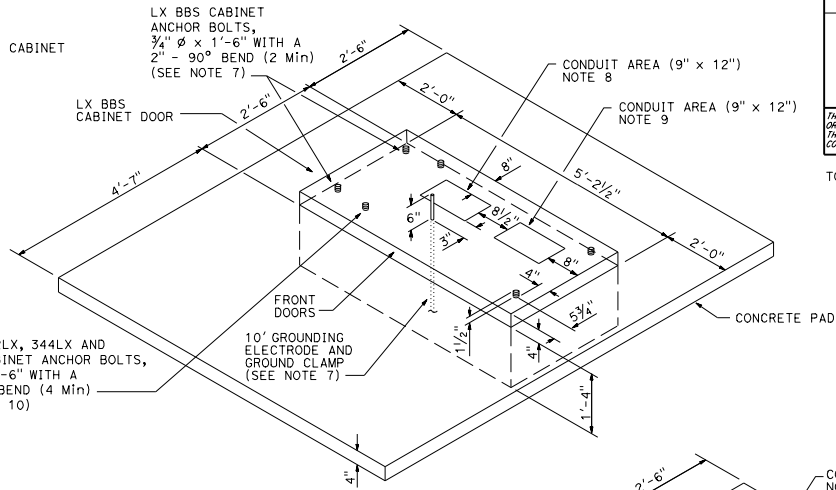

**LEFT-HAND INSTALLATION
DETAIL A**

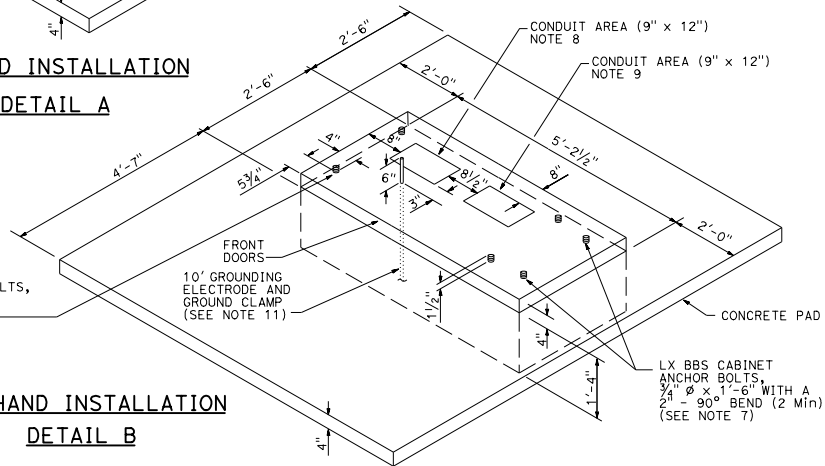

**RIGHT-HAND INSTALLATION
DETAIL B**

MODIFIED MODEL 342LX OR 344LX CABINET FOUNDATION DETAIL FOR BATTERY BACKUP SYSTEM

NOTES:

1. Controller units, plug-mounted equipment, shelf-mounted equipment and wall-mounted equipment shall be located to permit safe and easy removal or replacement without removing any other piece of equipment.
2. Cabinet fan may be installed at an alternate location near the top of the cabinet when approved by the Engineer.
3. Where telephone interconnect is required, a minimum of 5" clear vertical space shall be provided inside the cabinet for the equipment.
4. Telephone interconnect conductors shall be enclosed in a 3/4" or larger conduit through the foundation. Type 4 conduit shall be used to separate telephone and power conductors in cabinets.
5. The LX BBS cabinet shall be mounted to the model 342LX or 344LX cabinet with four 18-8 stainless steel hex head, fully-threaded, 3/4"-16 x 1" bolts; two washers per bolt, designed for 3/4" bolts and are 18-8 stainless steel, 1" outside diameter, round, and flat; and one K-Lock nut per bolt that is 18-8 stainless steel and a hex-nut.
6. All dimensions are nominal.
7. The dimensions of the BBS cabinet shall be verified prior to constructing the foundation of the Std model 342LX or 344LX cabinet foundation.
8. Conduit area, to 120 V Service.
9. Conduit area for the controller side of cabinet.
10. For Type LX cabinets details, see "Transportation Electrical Equipment Specifications".
11. Grounding electrode shall be placed 3 inches in front of the service conduit area.

STATE OF CALIFORNIA
DEPARTMENT OF TRANSPORTATION
**ELECTRICAL SYSTEMS
(CONTROLLER CABINET
FOUNDATION DETAILS)**

NO SCALE

RSP ES-3C2 DATED JULY 21, 2017 SUPPLEMENTS THE STANDARD PLANS BOOK DATED 2015.

REVISED STANDARD PLAN RSP ES-3C2

2015 REVISED STANDARD PLAN RSP ES-3C2

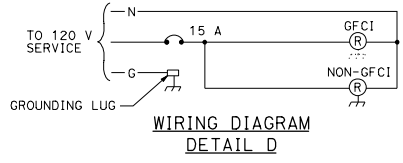
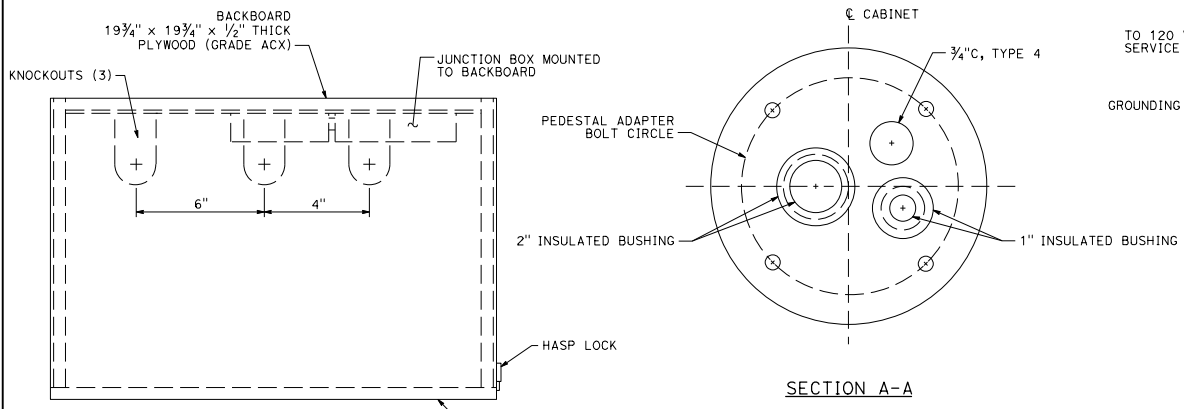

WIRING DIAGRAM
DETAIL D

NOTES:

1. Dimensions are nominal.
2. The steel pedestal, base plate, and bolt circle for the telephone demarcation cabinet shall be the same as that shown for a Type 1-C Standard. The steel pedestal shall be 2'-1" to 2'-6" in length. Anchor bolts shall be 3/4" ϕ x 1'-6" with a 2" - 90° bend. Four bolts required per cabinet.
3. Telephone interconnect conductors shall be enclosed in a 3/4" or larger conduit through the foundation. Type 4 conduit shall be used to separate telephone and power conductors in the cabinet and pedestal.
4. Mount cabinet on Type G cabinet pedestal and foundation (see RSP ES-3B).

DIST	COUNTY	ROUTE	POST MILES TOTAL PROJECT	SHEET NO.	TOTAL SHEETS

Theresa Gabriel
REGISTERED ELECTRICAL ENGINEER
No. E15129
Exp. 6-30-16
ELECTRICAL
STATE OF CALIFORNIA

APPROVAL DATE: April 15, 2016
PLANS APPROVAL DATE: _____
TO ACCOMPANY PLANS DATED _____

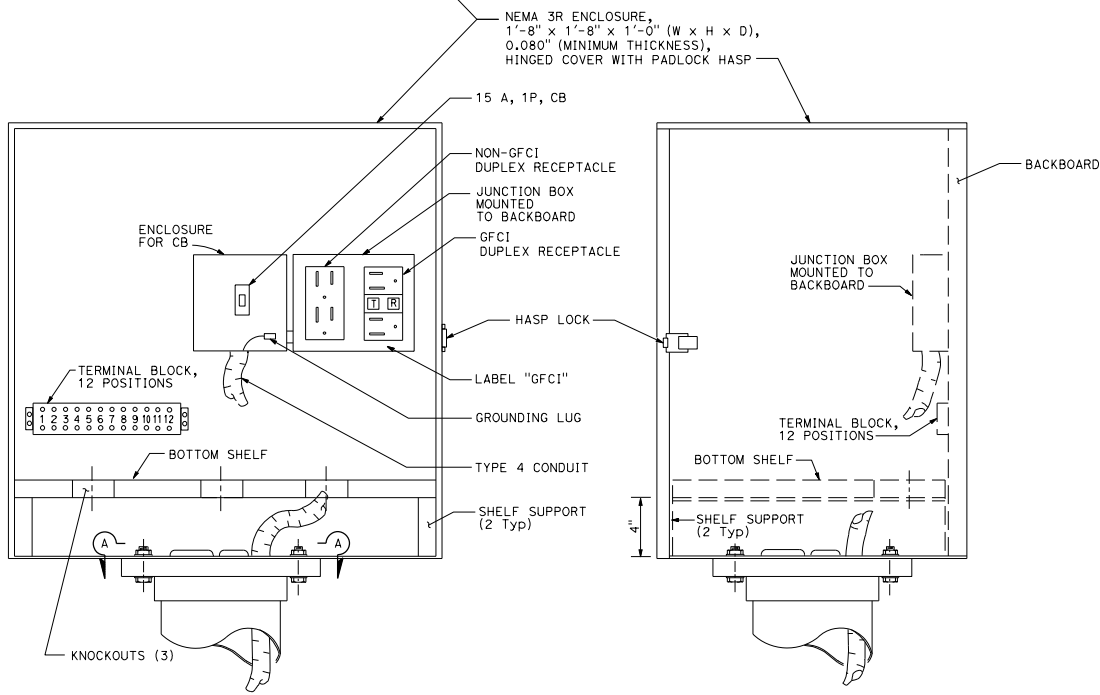

FASTENER SCHEDULE

BACKBOARD	4 - 3/4" (LENGTH) WOOD SCREWS
2 SHELF SUPPORTS	4 - 3/4" (LENGTH) WOOD SCREWS
JUNCTION BOX	4 - 1/2" (LENGTH) WOOD SCREWS
TERMINAL BLOCK	4 - 3/4" (LENGTH) WOOD SCREWS

STATE OF CALIFORNIA
DEPARTMENT OF TRANSPORTATION
**ELECTRICAL SYSTEMS
(TELEPHONE DEMARCATION
CABINET, TYPE A)**

NO SCALE
RSP ES-3D DATED APRIL 15, 2016 SUPERSEDES STANDARD PLAN ES-3D
DATED OCTOBER 30, 2015 - PAGE 431 OF THE STANDARD PLANS BOOK DATED 2015.

REVISED STANDARD PLAN RSP ES-3D

2015 REVISED STANDARD PLAN RSP ES-3D

DIST	COUNTY	ROUTE	POST MILES TOTAL PROJECT	SHEET TOTAL SHEETS

H. R. J.
 REGISTERED ELECTRICAL ENGINEER
 Hamid Zolfaghar
 No. E15636
 Exp. 12-31-17
 ELECTRICAL
 STATE OF CALIFORNIA

July 21, 2017
 PLANS APPROVAL DATE
 THE STATE OF CALIFORNIA OR ITS OFFICERS OR AGENTS SHALL NOT BE RESPONSIBLE FOR THE ACCURACY OR COMPLETENESS OF SCANNED COPIES OF THIS PLAN SHEET.

TO ACCOMPANY PLANS DATED _____

NOTE:
1. Dimensions are nominal.

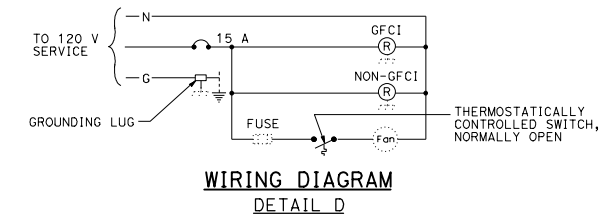
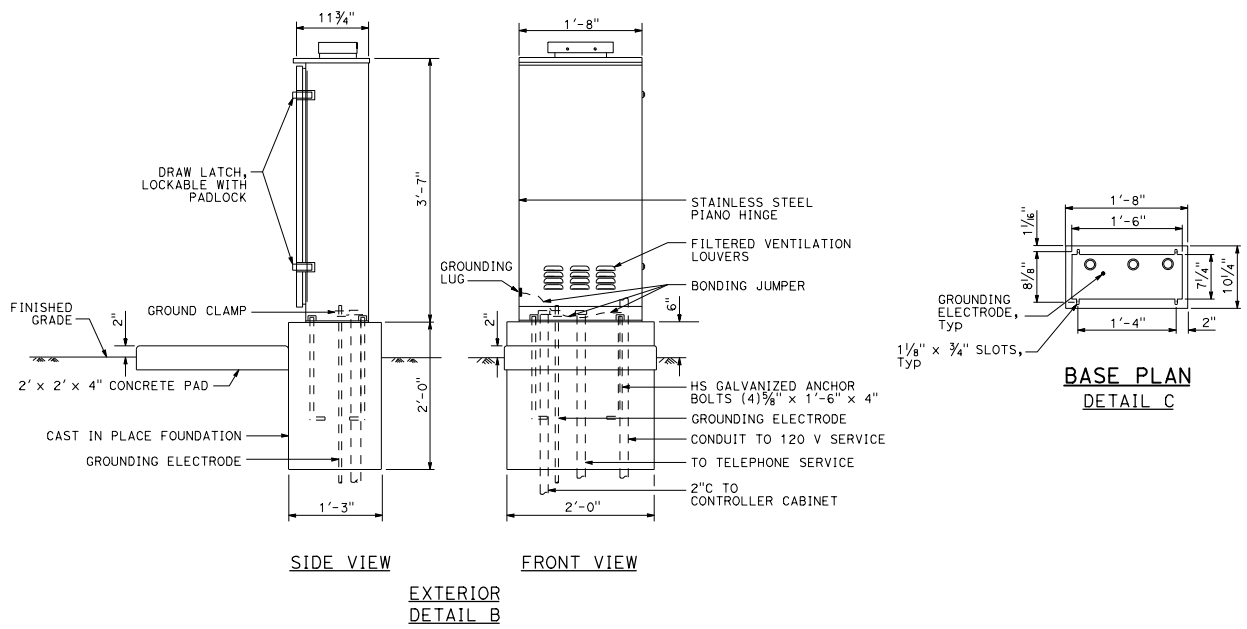
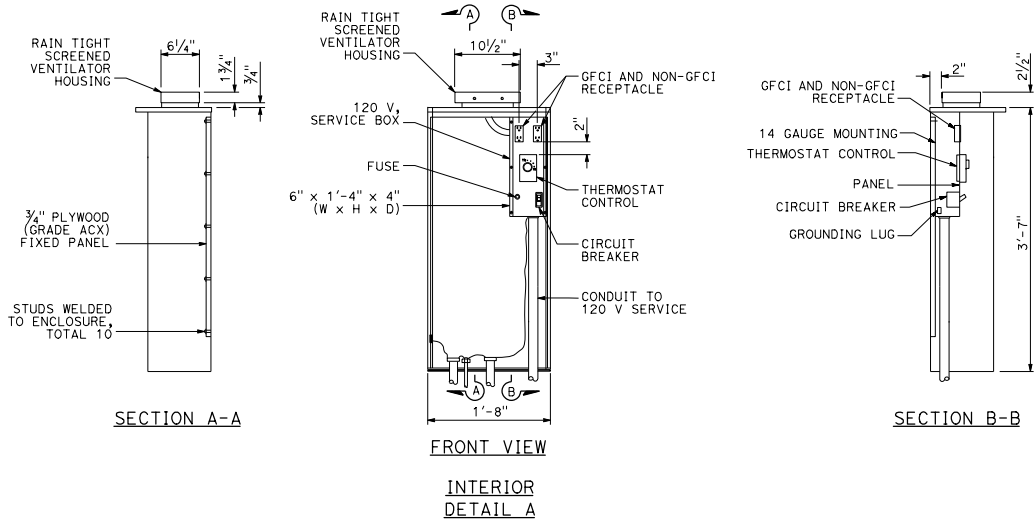

STATE OF CALIFORNIA
DEPARTMENT OF TRANSPORTATION
**ELECTRICAL SYSTEMS
(TELEPHONE DEMARCATION
CABINET, TYPE B)**

NO SCALE

RSP ES-3E DATED JULY 21, 2017 SUPERSEDES RSP ES-3E DATED APRIL 15, 2016 AND STANDARD PLAN ES-3E DATED OCTOBER 30, 2015 - PAGE 432 OF THE STANDARD PLANS BOOK DATED 2015.

REVISED STANDARD PLAN RSP ES-3E

2015 REVISED STANDARD PLAN RSP ES-3E

DIST	COUNTY	ROUTE	POST MILES TOTAL PROJECT	SHEET TOTAL SHEETS

H. R. F.
 REGISTERED ELECTRICAL ENGINEER
 Hamid Zolfaghar
 No. E15636
 Exp. 12-31-17
 STATE OF CALIFORNIA
 ELECTRICAL ENGINEER

July 21, 2017
 PLANS APPROVAL DATE
 THE STATE OF CALIFORNIA OR ITS OFFICERS OR AGENTS SHALL NOT BE RESPONSIBLE FOR THE ACCURACY OR COMPLETENESS OF SCANNED COPIES OF THIS PLAN SHEET.

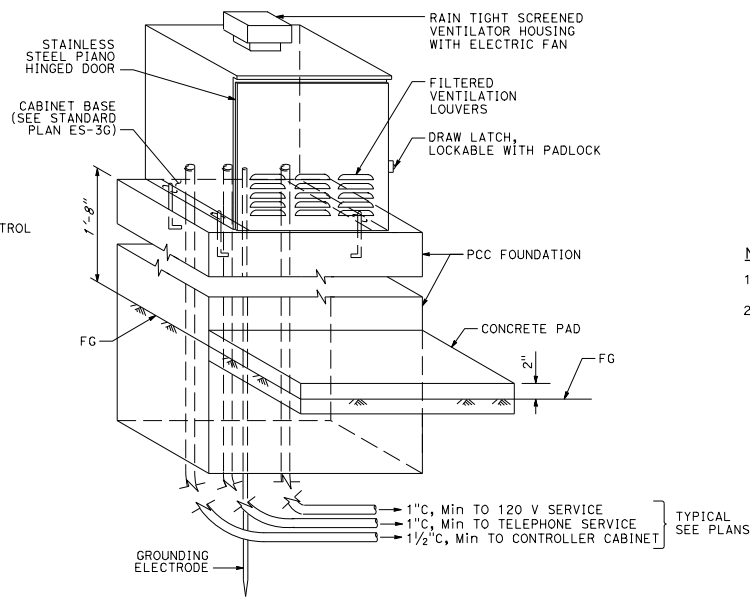
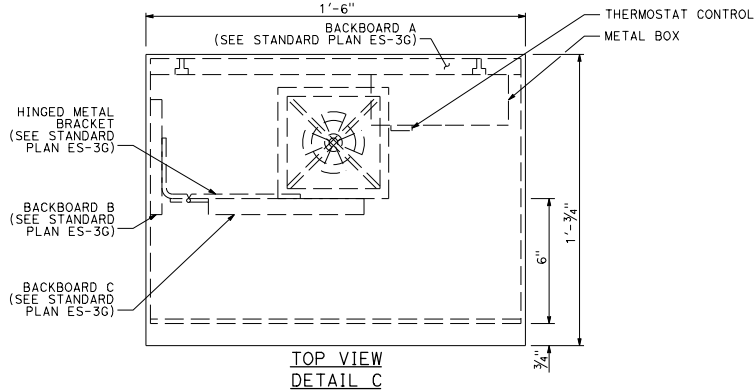
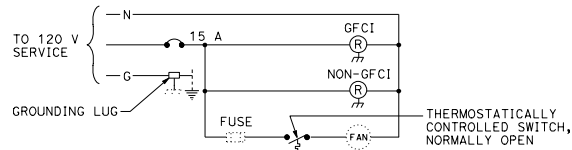

- NOTES:**
- Dimensions are nominal.
 - Hardware for fastening of mounting boards:
 - Fasten backboard A and backboard B to telephone demarcation cabinet with $\frac{3}{16}$ " ϕ x $\frac{3}{4}$ " stainless steel carriage bolts (8 required).
 - Fasten hinged metal bracket to backboard B and backboard C to hinged metal bracket with number No. 10 x $\frac{3}{4}$ " wood screws (9 required).

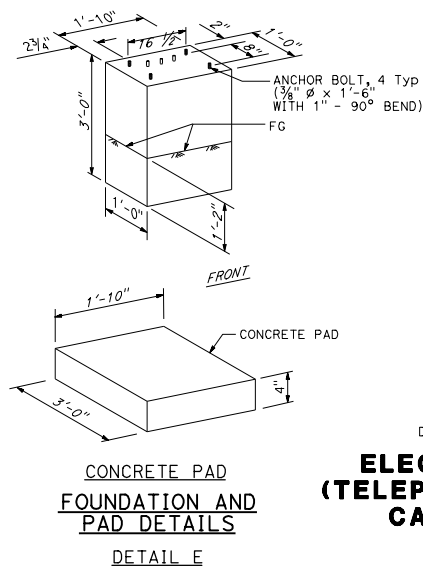
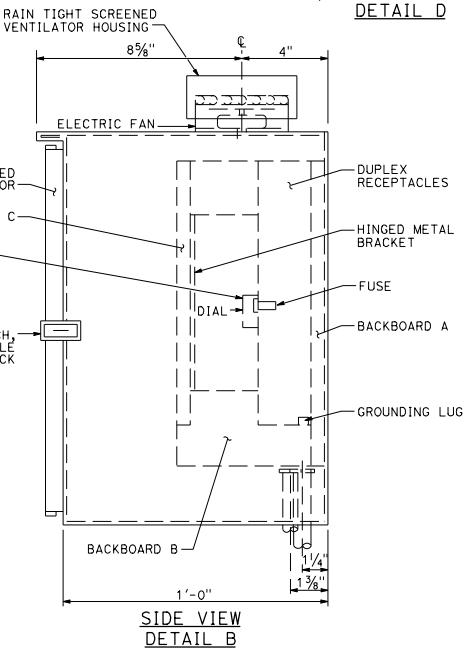
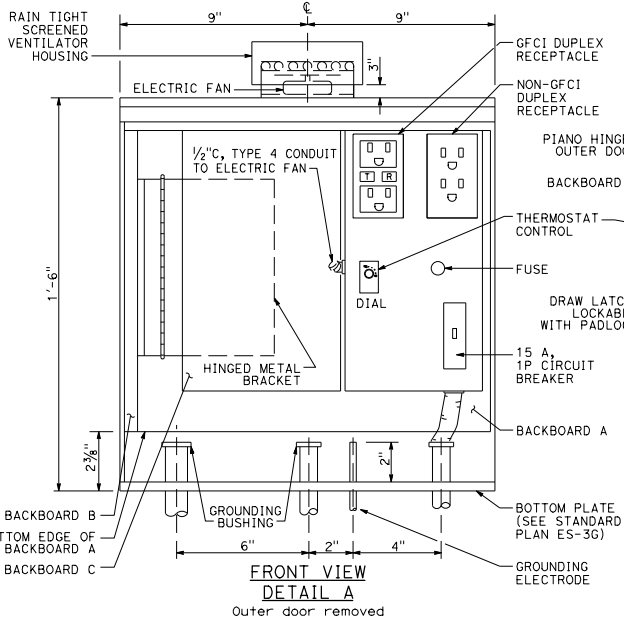

STATE OF CALIFORNIA
DEPARTMENT OF TRANSPORTATION

**ELECTRICAL SYSTEMS
(TELEPHONE DEMARCATION
CABINET, TYPE C)**

NO SCALE

RSP ES-3F DATED JULY 21, 2017 SUPERSEDES RSP ES-3F DATED APRIL 15, 2016 AND STANDARD PLAN ES-3F DATED OCTOBER 30, 2015 - PAGE 433 OF THE STANDARD PLANS BOOK DATED 2015.

REVISED STANDARD PLAN RSP ES-3F

2015 REVISED STANDARD PLAN RSP ES-3F

DIST	COUNTY	ROUTE	POST MILES TOTAL PROJECT	SHEET TOTAL SHEETS

 REGISTERED ELECTRICAL ENGINEER
 Hamid Zolfaghar
 No. E15636
 Exp. 12-31-17
 ELECTRICAL
 STATE OF CALIFORNIA

July 21, 2017
 PLANS APPROVAL DATE
 THE STATE OF CALIFORNIA OR ITS OFFICERS OR AGENTS SHALL NOT BE RESPONSIBLE FOR THE ACCURACY OR COMPLETENESS OF SCANNED COPIES OF THIS PLAN SHEET.

TO ACCOMPANY PLANS DATED _____

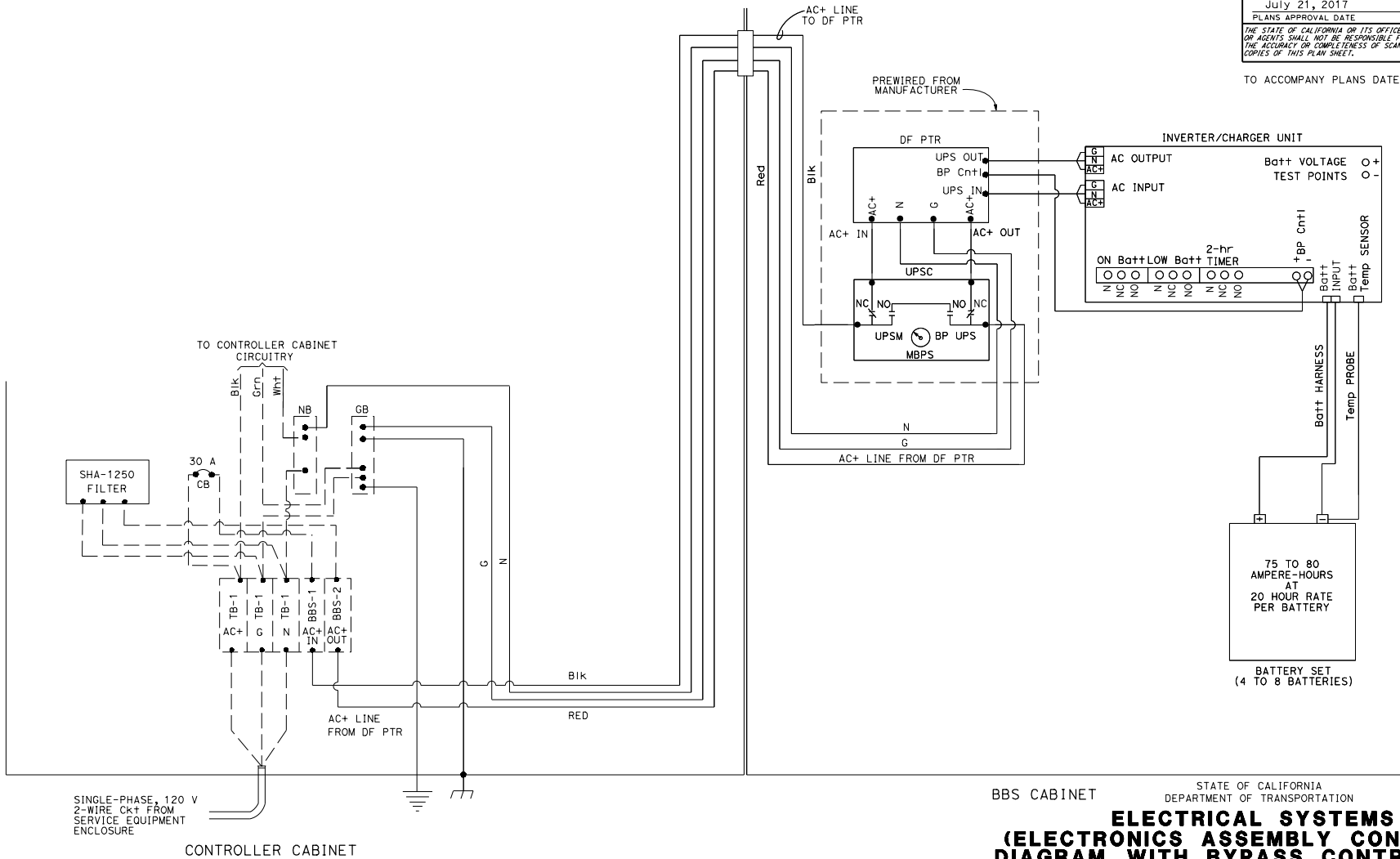

SINGLE-PHASE, 120 V
2-WIRE CKT FROM
SERVICE EQUIPMENT
ENCLOSURE

CONTROLLER CABINET

BBS CABINET
 STATE OF CALIFORNIA
 DEPARTMENT OF TRANSPORTATION
ELECTRICAL SYSTEMS
(ELECTRONICS ASSEMBLY CONNECTION
DIAGRAM, WITH BYPASS CONTROL LINE)
 NO SCALE
 RSP ES-31 DATED JULY 21, 2017 SUPERSEDES RSP ES-31 DATED APRIL 15, 2016 AND STANDARD
 PLAN ES-31 DATED OCTOBER 30, 2015 - PAGE 436 OF THE STANDARD PLANS BOOK DATED 2015.
REVISED STANDARD PLAN RSP ES-31

2015 REVISED STANDARD PLAN RSP ES-31

DIST	COUNTY	ROUTE	POST MILES TOTAL PROJECT	SHEET TOTAL SHEETS

 REGISTERED ELECTRICAL ENGINEER
 Hamid Zolfaghar
 No. E15636
 Exp. 12-31-17
 ELECTRICAL
 STATE OF CALIFORNIA

July 21, 2017
 PLANS APPROVAL DATE
 THE STATE OF CALIFORNIA OR ITS OFFICERS OR AGENTS SHALL NOT BE RESPONSIBLE FOR THE ACCURACY OR COMPLETENESS OF SCANNED COPIES OF THIS PLAN SHEET.

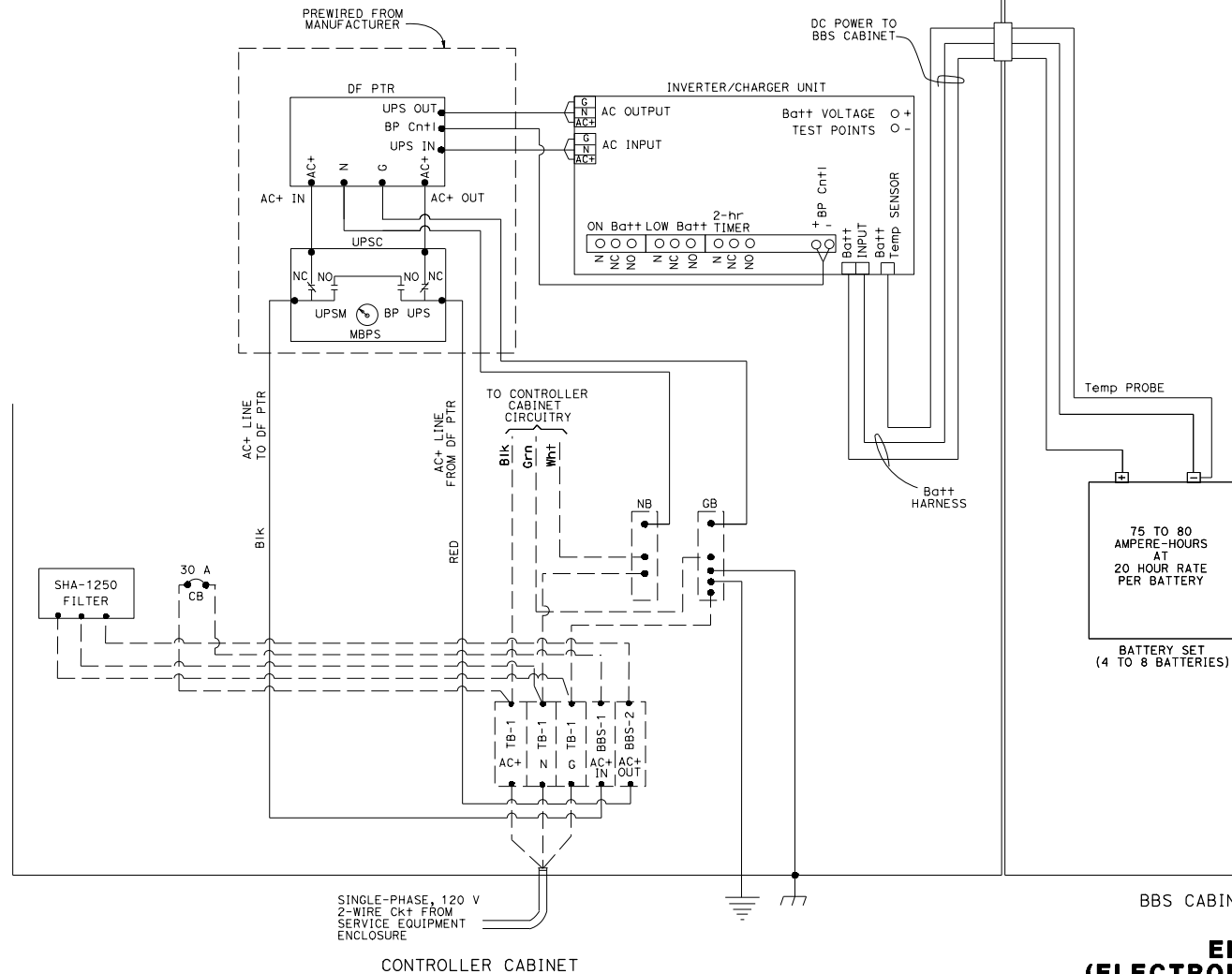

BBS CABINET
 STATE OF CALIFORNIA
 DEPARTMENT OF TRANSPORTATION
ELECTRICAL SYSTEMS
(ELECTRONICS ASSEMBLY CONNECTION
DIAGRAM, WITH BYPASS CONTROL LINE)
 NO SCALE
 RSP ES-3J DATED JULY 21, 2017 SUPERSEDES RSP ES-3J DATED APRIL 15, 2016 AND STANDARD PLAN ES-3J DATED OCTOBER 30, 2015 - PAGE 437 OF THE STANDARD PLANS BOOK DATED 2015.
REVISED STANDARD PLAN RSP ES-3J

2015 REVISED STANDARD PLAN RSP ES-3J

DIST	COUNTY	ROUTE	POST MILES TOTAL PROJECT	SHEET TOTAL SHEETS

H. R. J.
 REGISTERED ELECTRICAL ENGINEER
 Hamid Zolfaghar
 No. E15636
 Exp. 12-31-17
 ELECTRICAL
 STATE OF CALIFORNIA

PLANS APPROVAL DATE: July 21, 2017
 THE STATE OF CALIFORNIA OR ITS OFFICERS OR AGENTS SHALL NOT BE RESPONSIBLE FOR THE ACCURACY OR COMPLETENESS OF SCANNED COPIES OF THIS PLAN SHEET.

TO ACCOMPANY PLANS DATED _____

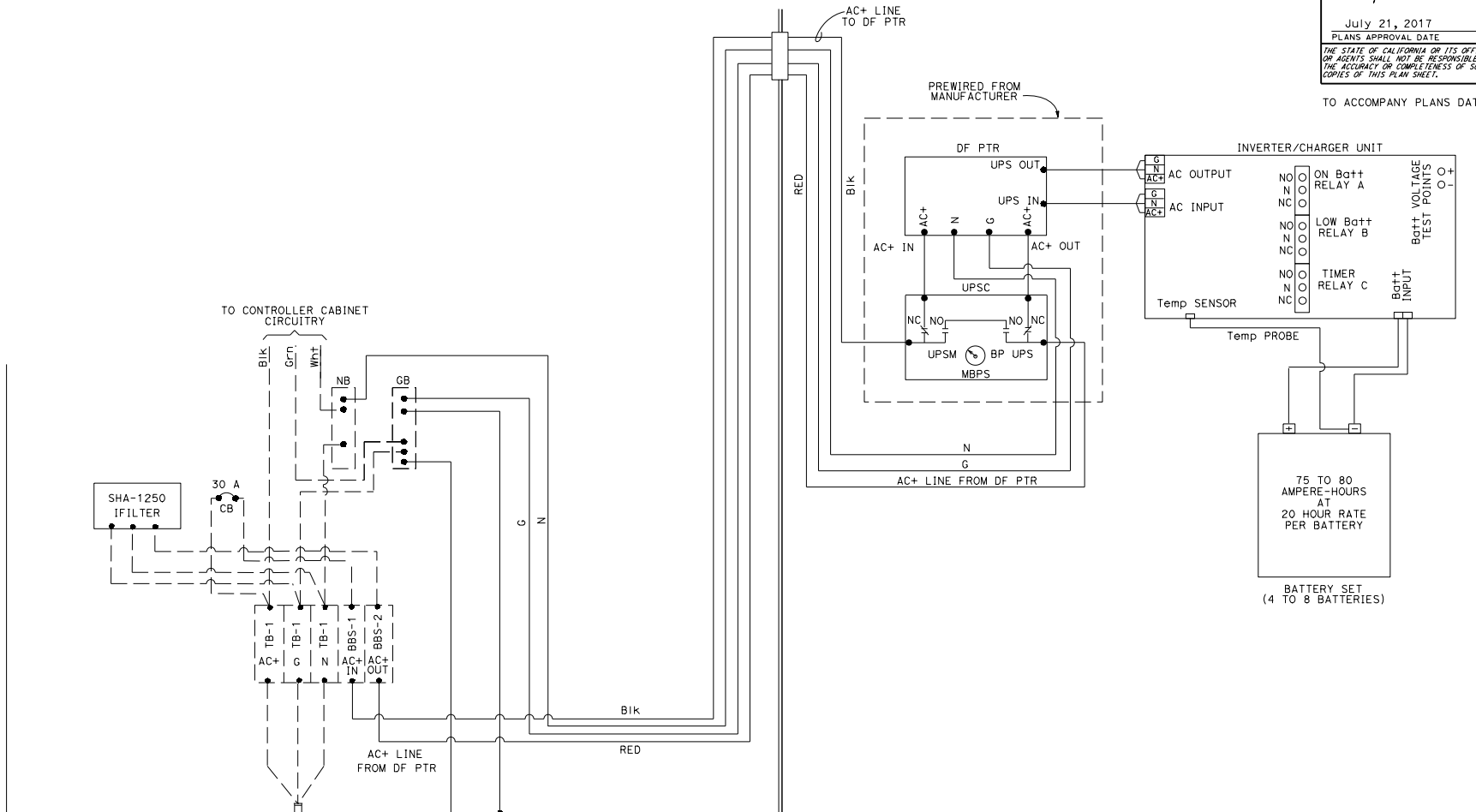

SINGLE-PHASE, 120 V
2-WIRE CKT FROM
SERVICE EQUIPMENT
ENCLOSURE

CONTROLLER CABINET

BBS CABINET

STATE OF CALIFORNIA
DEPARTMENT OF TRANSPORTATION
ELECTRICAL SYSTEMS
(ELECTRONICS ASSEMBLY CONNECTION
DIAGRAM, WITHOUT BYPASS CONTROL LINE)
NO SCALE

RSP ES-3K DATED JULY 21, 2017 SUPERSEDES RSP ES-3K DATED APRIL 15, 2016 AND STANDARD PLAN ES-3K DATED OCTOBER 30, 2015 - PAGE 438 OF THE STANDARD PLANS BOOK DATED 2015.

REVISED STANDARD PLAN RSP ES-3K

2015 REVISED STANDARD PLAN RSP ES-3K

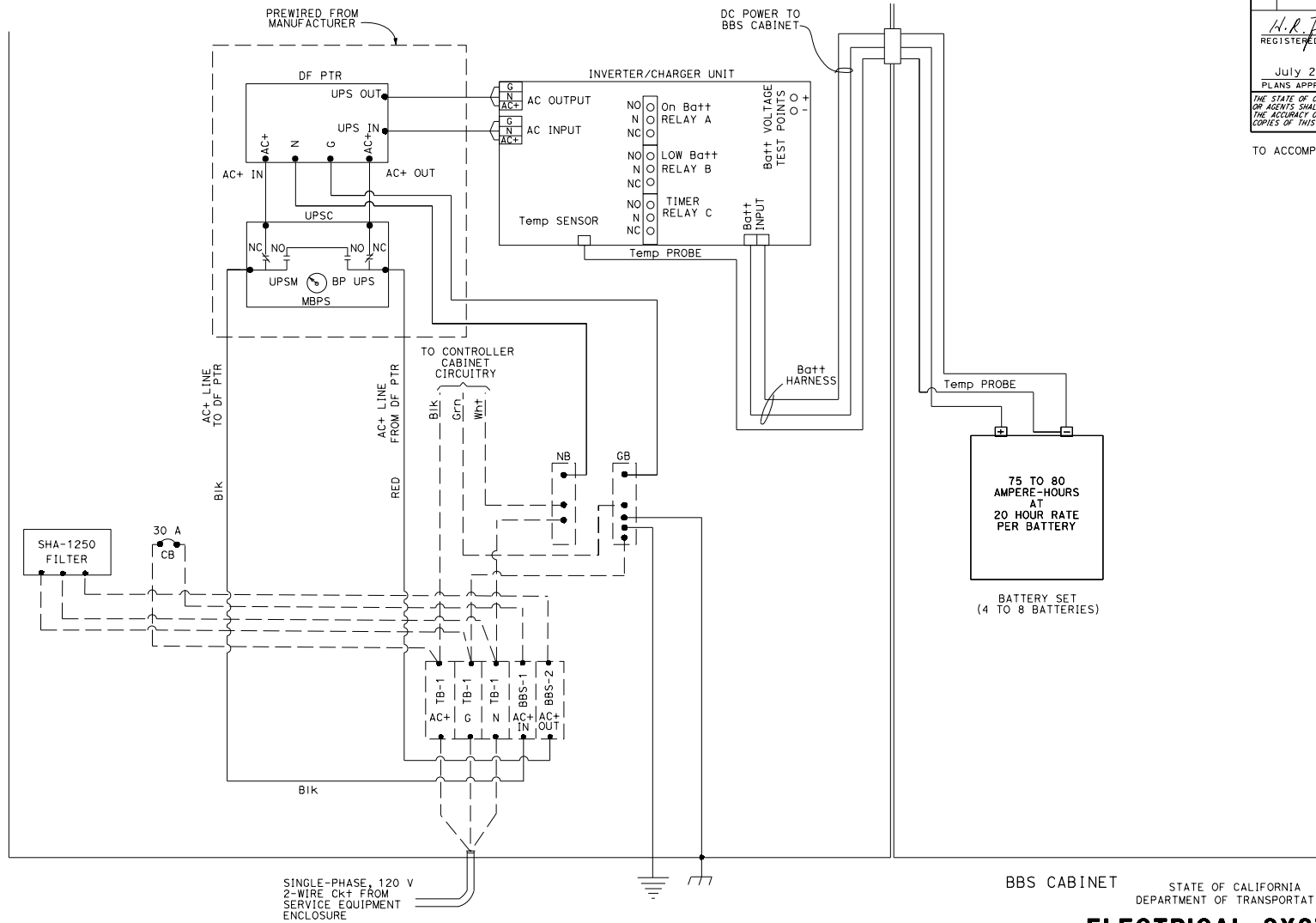

DIST	COUNTY	ROUTE	POST MILES TOTAL PROJECT	SHEET TOTAL SHEETS

H.R.F.
 REGISTERED ELECTRICAL ENGINEER
 Hamid Zolfaghar
 No. E15636
 Exp. 12-31-17
 ELECTRICAL
 STATE OF CALIFORNIA

July 21, 2017
 PLANS APPROVAL DATE
 THE STATE OF CALIFORNIA OR ITS OFFICERS OR AGENTS SHALL NOT BE RESPONSIBLE FOR THE ACCURACY OR COMPLETENESS OF SCANNED COPIES OF THIS PLAN SHEET.

TO ACCOMPANY PLANS DATED _____

2015 REVISED STANDARD PLAN RSP ES-3L

BBS CABINET STATE OF CALIFORNIA
DEPARTMENT OF TRANSPORTATION

**ELECTRICAL SYSTEMS
(ELECTRONICS ASSEMBLY CONNECTION
DIAGRAM, WITHOUT BYPASS CONTROL LINE)**
NO SCALE

RSP ES-3L DATED JULY 21, 2017 SUPERSEDES RSP ES-3L DATED APRIL 15, 2016 AND STANDARD PLAN ES-3L DATED OCTOBER 30, 2015 - PAGE 439 OF THE STANDARD PLANS BOOK DATED 2015.

REVISED STANDARD PLAN RSP ES-3L

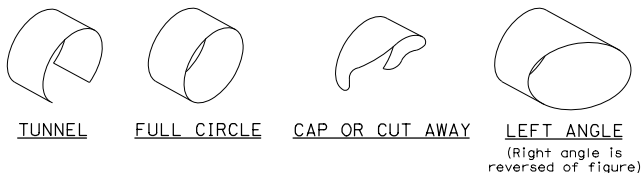

VISORS

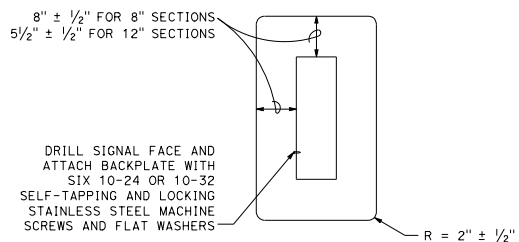

8" AND 12" SECTIONS
BACKPLATE

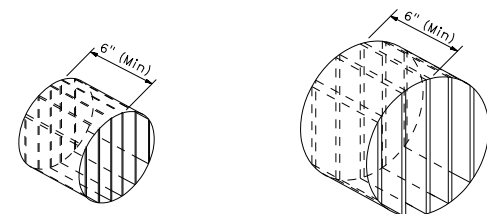

ISOMETRIC VIEW

ISOMETRIC VIEW

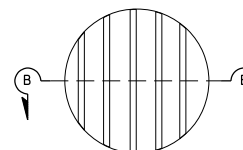
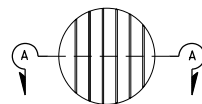
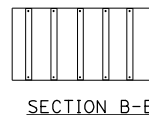

DIRECTIONAL LOUVER

Directional louvers shall be oriented and secured in place with one plated brass machine screw and nut.

DIST	COUNTY	ROUTE	POST MILES TOTAL PROJECT	SHEET TOTAL SHEETS

H.R.F.
 REGISTERED ELECTRICAL ENGINEER
 Hamid Zolfaghar
 No. E15636
 Exp. 12-31-17
 REGISTERED PROFESSIONAL ENGINEER
 ELECTRICAL
 STATE OF CALIFORNIA

PLANS APPROVAL DATE: July 21, 2017

THE STATE OF CALIFORNIA OR ITS OFFICERS OR AGENTS SHALL NOT BE RESPONSIBLE FOR THE ACCURACY OR COMPLETENESS OF SCANNED COPIES OF THIS PLAN SHEET.

TO ACCOMPANY PLANS DATED _____

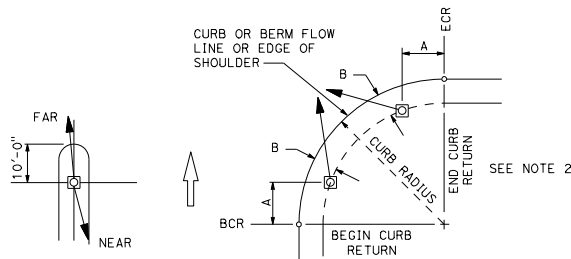

NOTES:

1. Typical signal pole placement unless dimensioned on plans.
2. For A and B dimensions, see Pole Schedule.

SIGNAL STANDARD PLACEMENT DIMENSIONS AND EQUIPMENT LOCATIONS

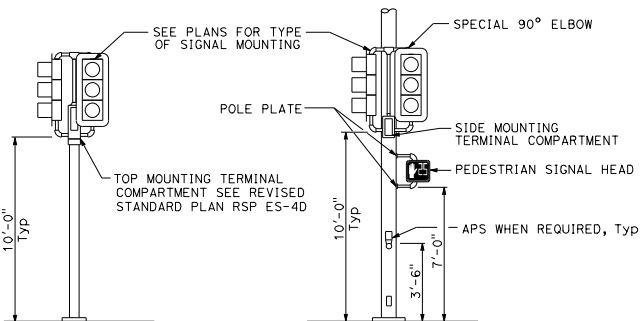

TOP MOUNTED SIGNALS (TV)

SIDE MOUNTED SIGNALS (SV AND SP)

Type 1-A, 1-B, 1-C and 1-D standard as indicated on the plans

Normally used on standards with luminaire or signal mast arm

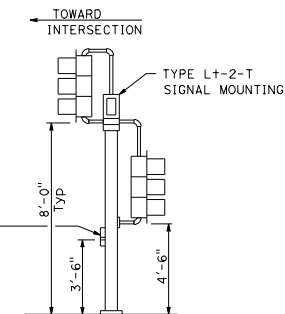

LEFT TURN LANE SIGNAL

Type 1-A, 1-B, 1-C and 1-D standard as indicated on plans

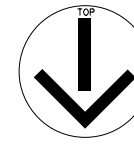
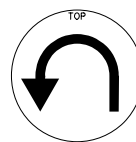

SIGNAL FACES

STATE OF CALIFORNIA
DEPARTMENT OF TRANSPORTATION

ELECTRICAL SYSTEMS (SIGNAL HEADS AND MOUNTINGS)

NO SCALE

RSP ES-4C DATED JULY 21, 2017 SUPERSEDES STANDARD PLAN ES-4C DATED OCTOBER 30, 2015 - PAGE 442 OF THE STANDARD PLANS BOOK DATED 2015.

REVISED STANDARD PLAN RSP ES-4C

2015 REVISED STANDARD PLAN RSP ES-4C

DIST	COUNTY	ROUTE	POST MILES TOTAL PROJECT	SHEET TOTAL NO. SHEETS
 REGISTERED ELECTRICAL ENGINEER Hamid Zolfaghar No. E15636 Exp. 12-31-17 ELECTRICAL ENGINEER STATE OF CALIFORNIA				
PLANS APPROVAL DATE: July 21, 2017				
THE STATE OF CALIFORNIA OR ITS OFFICERS OR AGENTS SHALL NOT BE RESPONSIBLE FOR THE ACCURACY OR COMPLETENESS OF SCANNED COPIES OF THIS PLAN SHEET.				

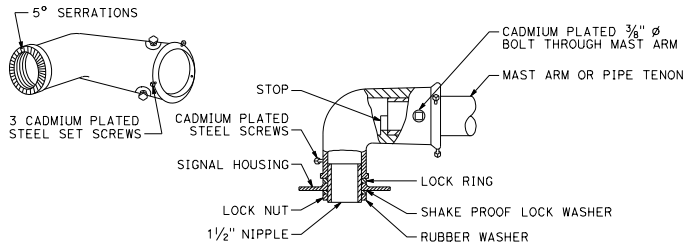

**TYPE MAT
MAST ARM MOUNTING**
For 2 NPS pipe, see Note 1.

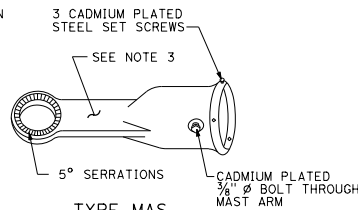

**TYPE MAS
MAST ARM MOUNTING**
For 2 NPS pipe, see Note 1.

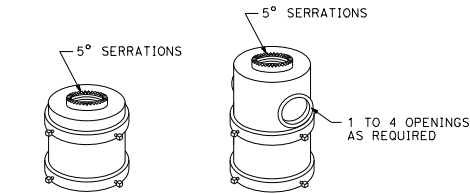

FOR ONE MOUNTING FOR MULTIPLE MOUNTINGS

TOP MOUNTINGS
For 4 NPS pipe, see Note 2.

NOTES:

1. After mast arm signal has been plumbed and secured, drill $\frac{1}{8}$ " hole through mast arm tenon in line with slip fitter hole. Place a cadmium plated $\frac{3}{8}$ " ϕ galvanized bolt with washer under bolt head through hole and secure with washer, nut, and locknut. Seal openings between mast arm mountings and mast arm with mastic.
2. Threaded top mounted slip fitter openings shall be $\frac{1}{2}$ " NPS. Serrations in fittings shall match those on bottom of signal heads or in lock ring. Top opening shall be offset when backplate is used.
3. Wireway shall have a cross section area of 0.95 square inch minimum. Minimum width of $\frac{1}{2}$ ".

SIGNAL SLIP FITTERS

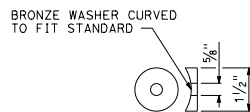

DETAIL C

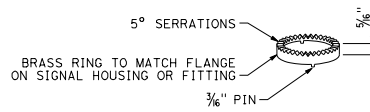

LOCK RING

Use where locking ring is not integral with signal housing or fitting.

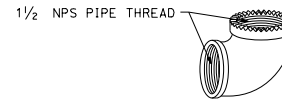

SPECIAL 90° ELBOW

One for each signal head, except those with special slip fitter mounting

MISCELLANEOUS MOUNTING HARDWARE

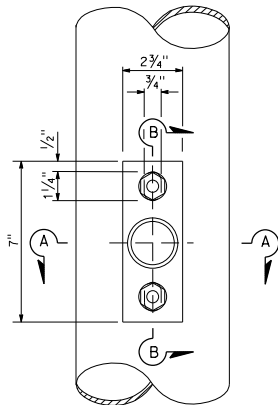

TOP VIEW

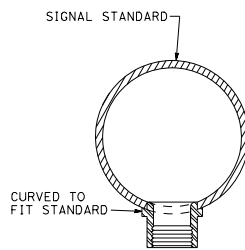

SECTION A-A

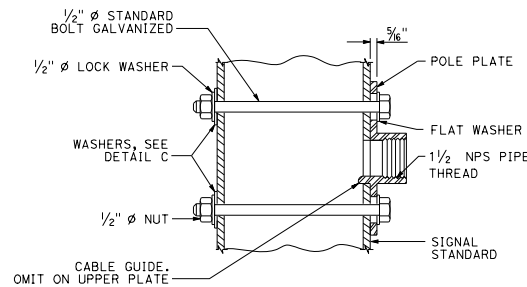

SECTION B-B

**POLE PLATE FOR SIDE MOUNTED SIGNAL HEAD
WITHOUT TERMINAL COMPARTMENT**

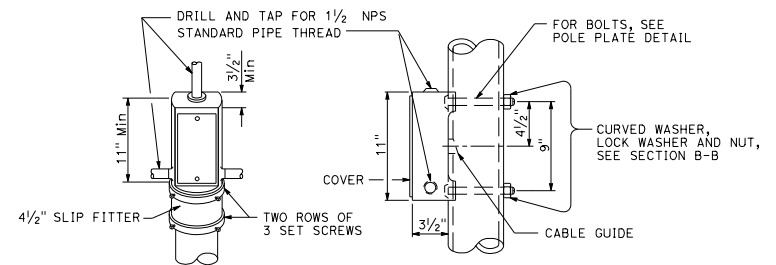

TOP MOUNTING

SIDE MOUNTING

TERMINAL COMPARTMENT

STATE OF CALIFORNIA
DEPARTMENT OF TRANSPORTATION
**ELECTRICAL SYSTEMS
(SIGNAL HEAD MOUNTING)**
NO SCALE

RSP ES-4D DATED JULY 21, 2017 SUPERSEDES STANDARD PLAN ES-4D
DATED OCTOBER 30, 2015 - PAGE 443 OF THE STANDARD PLANS BOOK DATED 2015.

REVISED STANDARD PLAN RSP ES-4D

2015 REVISED STANDARD PLAN RSP ES-4D

DIST	COUNTY	ROUTE	POST MILES TOTAL PROJECT	SHEET TOTAL NO. SHEETS
 REGISTERED ELECTRICAL ENGINEER Hamid Zolfaghar No. E15636 Exp. 12-31-19 ELECTRICAL STATE OF CALIFORNIA				
APRIL 20, 2018 PLANS APPROVAL DATE				
THE STATE OF CALIFORNIA OR ITS OFFICERS OR AGENTS SHALL NOT BE RESPONSIBLE FOR THE ACCURACY OR COMPLETENESS OF SCANNED COPIES OF THIS PLAN SHEET.				

TO ACCOMPANY PLANS DATED _____

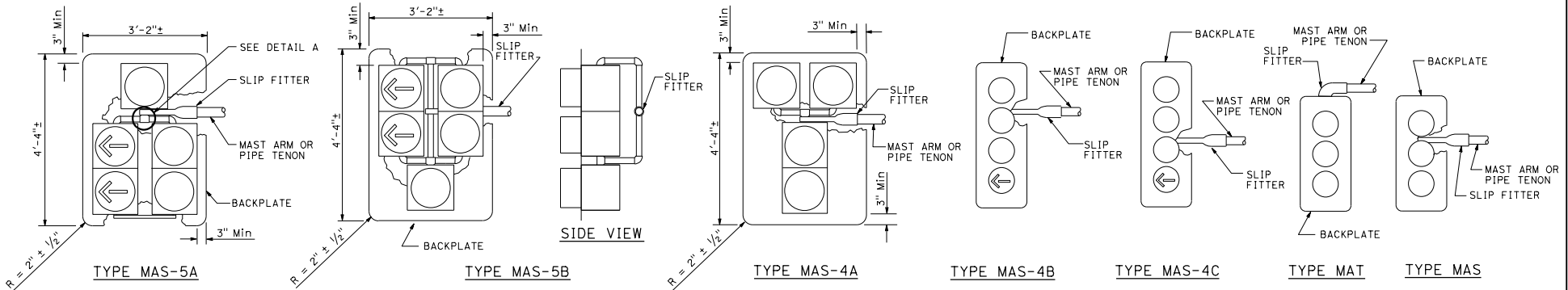

MAST ARM MOUNTINGS

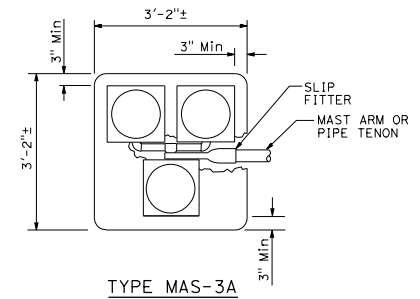
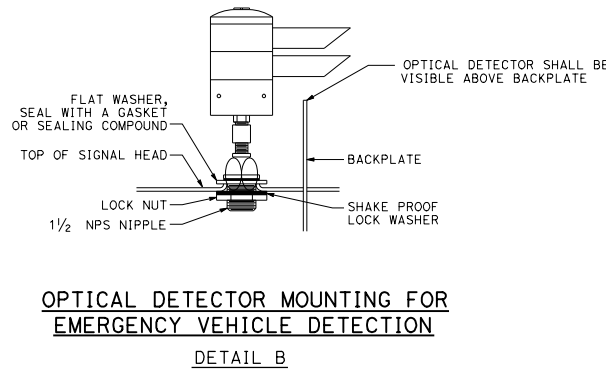
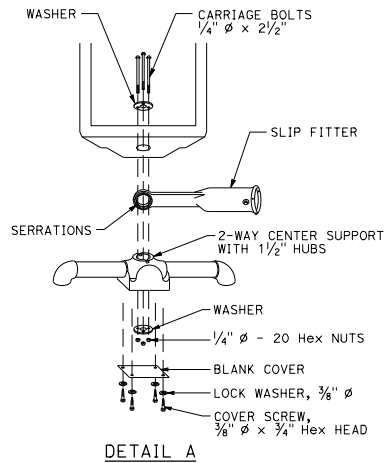

STATE OF CALIFORNIA
DEPARTMENT OF TRANSPORTATION
**ELECTRICAL SYSTEMS
(SIGNAL HEADS AND
OPTICAL DETECTOR MOUNTING)**
NO SCALE

RSP ES-4E DATED APRIL 20, 2018 SUPERSEDES STANDARD PLAN ES-4E
DATED OCTOBER 30, 2015 - PAGE 444 OF THE STANDARD PLANS BOOK DATED 2015.
REVISED STANDARD PLAN RSP ES-4E

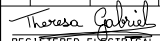
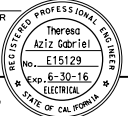
DIST	COUNTY	ROUTE	POST MILES TOTAL PROJECT	SHEET TOTAL SHEETS
 REGISTERED ELECTRICAL ENGINEER				
April 15, 2016 PLANS APPROVAL DATE				
				
THE STATE OF CALIFORNIA OR ITS OFFICERS OR AGENTS SHALL NOT BE RESPONSIBLE FOR THE ACCURACY OR COMPLETENESS OF SCANNED COPIES OF THIS PLAN SHEET.				

TO ACCOMPANY PLANS DATED _____

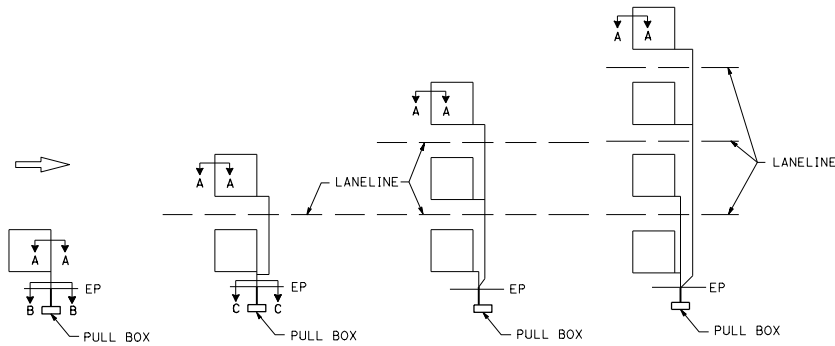

SAW CUT DETAILS

Type A loop detector configurations illustrated

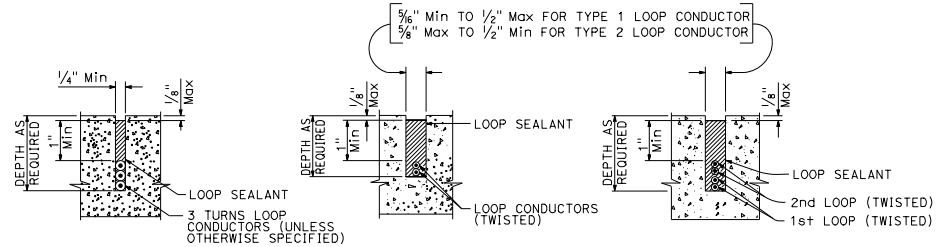

SECTION A-A

SECTION B-B

SECTION C-C

SLOT DETAILS - TYPE 1 AND TYPE 2 LOOP CONDUCTOR

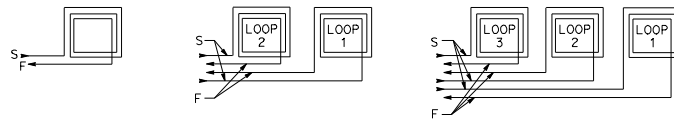

WINDING DETAILS

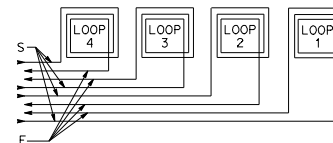

ABBREVIATIONS:

- S - START
- F - FINISH

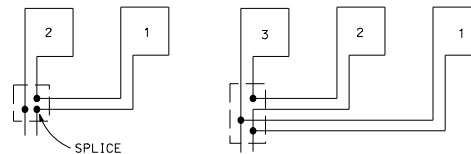

TYPICAL LOOP CONNECTIONS

Dashed lines represent the pull box

STATE OF CALIFORNIA
DEPARTMENT OF TRANSPORTATION
**ELECTRICAL SYSTEMS
(LOOP DETECTORS)**

NO SCALE

RSP ES-5A DATED APRIL 15, 2016 SUPERSEDES STANDARD PLAN ES-5A
DATED OCTOBER 30, 2015 - PAGE 445 OF THE STANDARD PLANS BOOK DATED 2015.

REVISED STANDARD PLAN RSP ES-5A

2015 REVISED STANDARD PLAN RSP ES-5A

DIST	COUNTY	ROUTE	POST MILES TOTAL PROJECT	SHEET NO.	TOTAL SHEETS
<i>Theresa Gabriel</i> REGISTERED ELECTRICAL ENGINEER No. E15129 April 15, 2016 PLANS APPROVAL DATE THE STATE OF CALIFORNIA OR ITS OFFICERS OR AGENTS SHALL NOT BE RESPONSIBLE FOR THE ACCURACY OR COMPLETENESS OF SCANNED COPIES OF THIS PLAN SHEET.					
TO ACCOMPANY PLANS DATED _____					

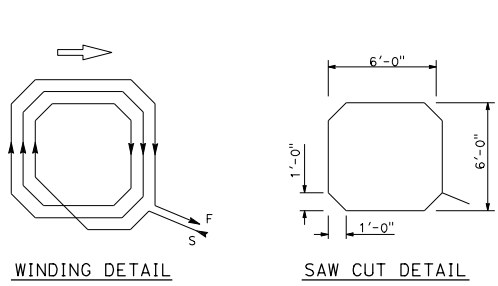
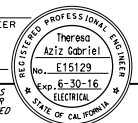

TYPE A LOOP DETECTOR CONFIGURATION

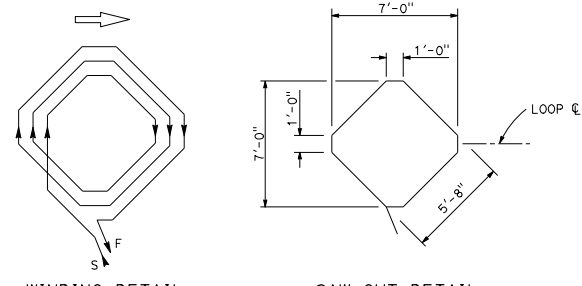

TYPE B LOOP DETECTOR CONFIGURATION

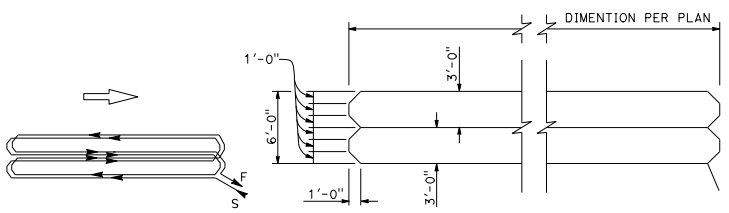

TYPE C LOOP DETECTOR CONFIGURATION

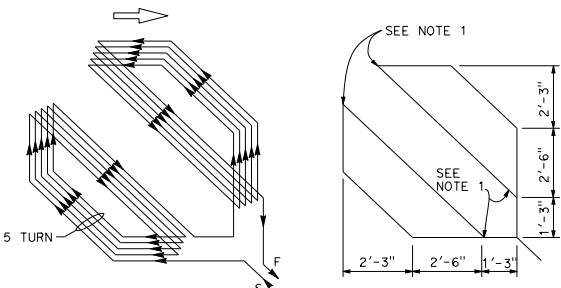

TYPE D LOOP DETECTOR CONFIGURATION

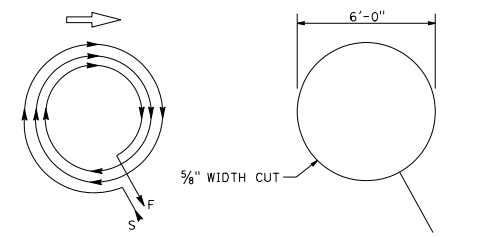

TYPE E LOOP DETECTOR CONFIGURATION

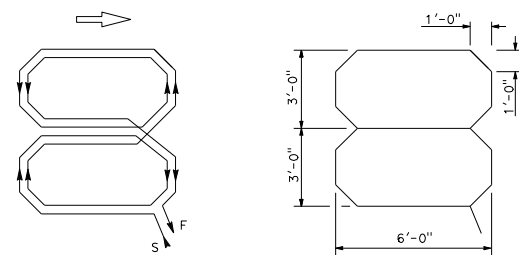

TYPE Q LOOP DETECTOR CONFIGURATION

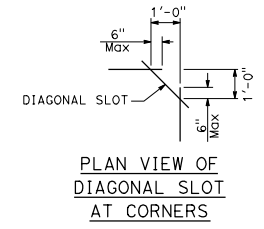

PLAN VIEW OF DIAGONAL SLOT AT CORNERS

- NOTES:**
1. Round corners of acute angle saw cuts to prevent damage to conductors.
 2. Typical distance separating loops from edge to edge is 10' for Type A, B, D and E installation in single lane.
 3. Use Type D loops for limit line detection and bicycle lanes.

STATE OF CALIFORNIA
DEPARTMENT OF TRANSPORTATION
ELECTRICAL SYSTEMS (DETECTORS)

NO SCALE
RSP ES-5B DATED APRIL 15, 2016 SUPERSEDES STANDARD PLAN ES-5B
DATED OCTOBER 30, 2015 - PAGE 446 OF THE STANDARD PLANS BOOK DATED 2015.

REVISED STANDARD PLAN RSP ES-5B

2015 REVISED STANDARD PLAN RSP ES-5B

DIST	COUNTY	ROUTE	POST MILES TOTAL PROJECT	SHEET TOTAL SHEETS

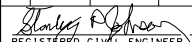

 REGISTERED CIVIL ENGINEER
 No. CS7193
 Exp. 3-31-18
 CIVIL
 STATE OF CALIFORNIA

July 21, 2017
 PLANS APPROVAL DATE
 THE STATE OF CALIFORNIA OR ITS OFFICERS OR AGENTS SHALL NOT BE RESPONSIBLE FOR THE ACCURACY OR COMPLETENESS OF SCANNED COPIES OF THIS PLAN SHEET.

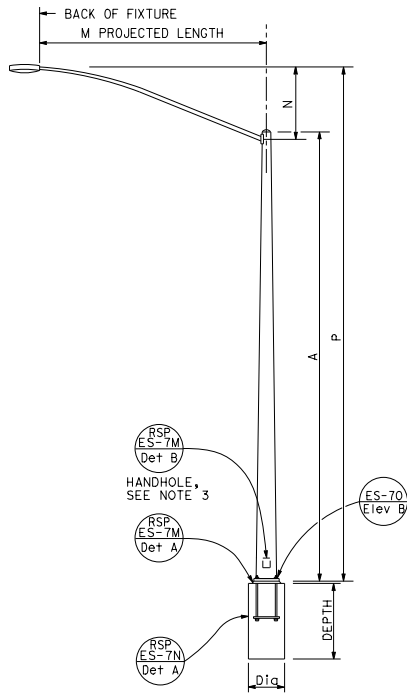
TO ACCOMPANY PLANS DATED _____

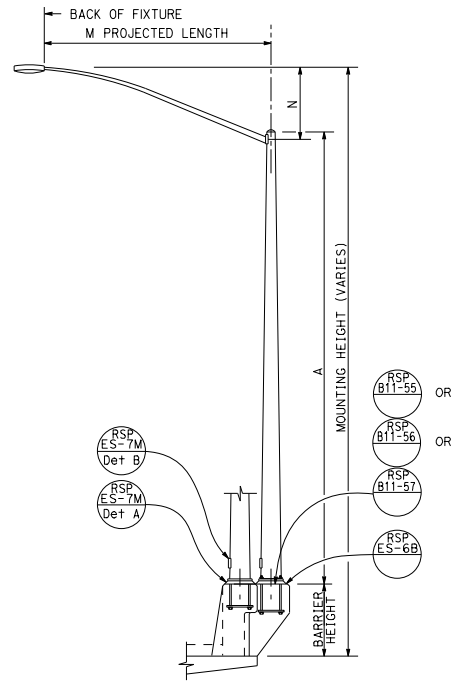

TYPE 15 AND TYPE 21
ELEVATION A



TYPE 15 AND TYPE 21 BARRIER RAIL MOUNTED
ELEVATION B

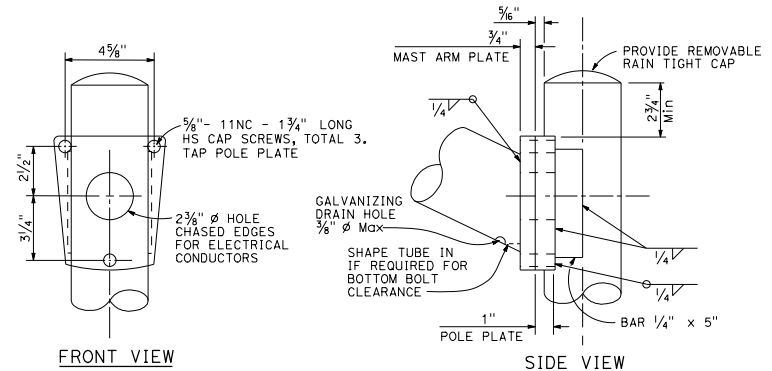

LUMINAIRE MAST ARM CONNECTION
DETAIL R

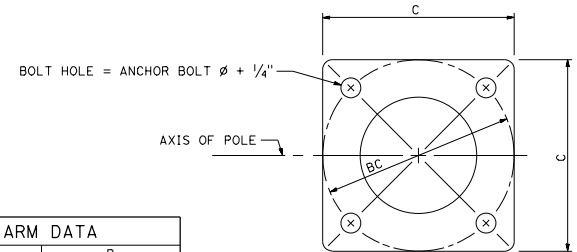

BASE PLATE
DETAIL A

POLE TYPE	POLE DATA				BASE PLATE DATA			CIDH PILE FOUNDATION	
	A HEIGHT	Min OD BASE	TOP	WALL THICKNESS	C	BC = BOLT CIRCLE	THICKNESS	ANCHOR BOLT SIZE	Dia DEPTH
15	30'-0"	8"	3 1/8"	0.1196"	1'-0"	1'-0"	1 1/2"	1" ø x 36" *	2'-6" 6'-0"
21	35'-0"	8 3/8"	3 3/8"	0.1793"			2"	1 1/4" ø x 36" *	7'-0"

* FOR BARRIER RAIL BOLTS, SEE REVISED STANDARD PLAN RSP ES-6B.

NOTES:

1.  Indicates mast arm length to be used unless otherwise noted on the plans.
2. For Type 15-SB, use Type 15 standard with Type 30 slip base plate details, see Standard Plan ES-6F.
3. Handhole shall be located on the downstream side of traffic.
4. For additional notes and details, see Revised Standard Plans RSP ES-7M and RSP ES-7N.

LUMINAIRE MAST ARM DATA				
M PROJECTED LENGTH	N RISE	Min OD AT POLE	NOMINAL THICKNESS	P
6'-0"	2'-0"±	3/4"	0.1196"	TYPE 15 TYPE 21
8'-0"	2'-6"±	3/2"		31'-6"± 36'-6"±
10'-0"	3'-3"±	3 7/8"		32'-0"± 37'-0"±
12'-0"	4'-3"±			32'-9"± 37'-9"±
14'-0"	4'-9"±	4 1/4"		33'-9"± 38'-9"±
15'-0"	4'-9"±	4 1/4"		34'-3"± 39'-3"±

STATE OF CALIFORNIA
DEPARTMENT OF TRANSPORTATION
ELECTRICAL SYSTEMS
(LIGHTING STANDARD,
TYPES 15 AND 21)

NO SCALE

RSP ES-6A DATED JULY 21, 2017 SUPERSEDES RSP ES-6A DATED JULY 15, 2016 AND STANDARD PLAN ES-6A DATED OCTOBER 30, 2015 - PAGE 449 OF THE STANDARD PLANS BOOK DATED 2015.

REVISED STANDARD PLAN RSP ES-6A

2015 REVISED STANDARD PLAN RSP ES-6A

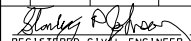
Dist	COUNTY	ROUTE	POST MILES TOTAL PROJECT	SHEET TOTAL NO. SHEETS
 REGISTERED CIVIL ENGINEER				
July 15, 2016 PLANS APPROVAL DATE				
No. CS793 No. 3-31-18 CIVIL				
THE STATE OF CALIFORNIA OR ITS OFFICERS OR AGENTS SHALL NOT BE RESPONSIBLE FOR THE ACCURACY OR COMPLETENESS OF SCANNED COPIES OF THIS PLAN SHEET.				

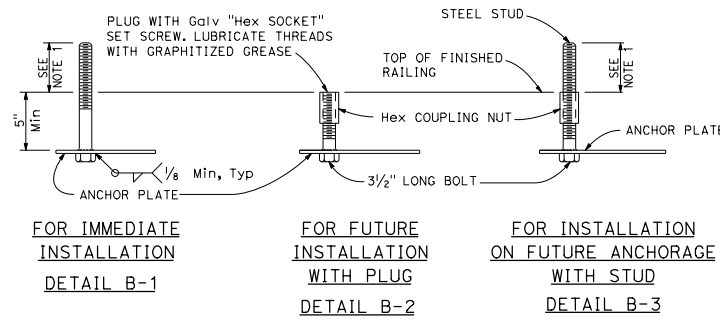

ELECTROLIER ANCHORAGES
DETAIL B

NOTES:

- Anchor bolt or stud length shall be such that thread extends 1/2" maximum above nut on level base plate after grouting. See Detail N.
- Electrolier anchor bolts shall be held in position for pouring by means of anchor plates and suitable templates. Deviation from the true position, vertical and height shall not exceed 1/16".
- See railing sheets for reinforcement and structural details at electroliers and pull boxes.

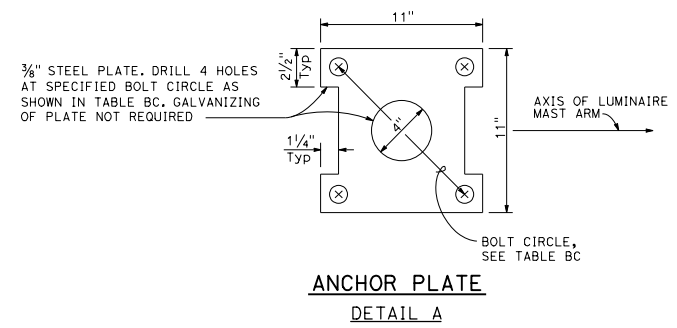

TYPE	BC = BOLT CIRCLE	ANCHOR BOLT DIAMETER	COUPLING NUT BASIC LENGTH	SET SCREW LENGTH DETAIL B-2
15	1'-0"	1"	3"	1 1/2"
21		1/4"	3 3/4"	1 7/8"

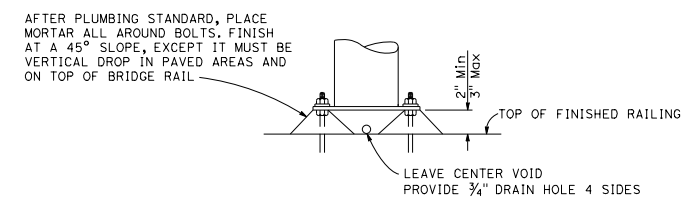

GROUTING AT ELECTROLIER
DETAIL N

STATE OF CALIFORNIA
DEPARTMENT OF TRANSPORTATION

**ELECTRICAL SYSTEMS
(ELECTROLIER ANCHORAGE AND
GROUTING FOR
TYPE 15 AND TYPE 21
BARRIER RAIL MOUNTED)**

NO SCALE
RSP ES-6B DATED JULY 15, 2016 SUPERSEDES STANDARD PLAN ES-6B
DATED OCTOBER 30, 2015 - PAGE 450 OF THE STANDARD PLANS BOOK DATED 2015.

REVISED STANDARD PLAN RSP ES-6B

2015 REVISED STANDARD PLAN RSP ES-6B

LUMINAIRE MAST ARM DATA			
M PROJECTED LENGTH	N RISE	Min OD AT POLE	NOMINAL THICKNESS
15'-0"	4'-9"±	4 1/2"	0.1196"
20'-0"	2'-6"±	5"	0.1793"

POLE DATA				
POLE EXTENSION TYPE	HEIGHT "H"	Min OD		THICKNESS
		BASE	TOP	
5	5'-0"	6 1/2"	5 1/8"	0.1793"
10	10'-0"	7 1/4"		

Dist	COUNTY	ROUTE	POST MILES TOTAL PROJECT	SHEET TOTAL No.



 Stanley P. Johnson
 REGISTERED CIVIL ENGINEER
 April 20, 2018
 PLANS APPROVAL DATE
 THE STATE OF CALIFORNIA OR ITS OFFICERS OR AGENTS SHALL NOT BE RESPONSIBLE FOR THE ACCURACY OR COMPLETENESS OF SCANNED COPIES OF THIS PLAN SHEET.

TO ACCOMPANY PLANS DATED _____

NOTES:

- The Contractor shall verify all controlling field dimensions before ordering or fabricating any material.
- Bolt hole locations may vary at the discretion of the Engineer.
- For Wind Loading see Revised Standard Plans RSP ES-7M.
- See Std Plan S13.
- Materials (Structural Steel):
 - fy = 55,000 psi tapered steel tube (pole)
 - fy = 50,000 psi unless otherwise noted

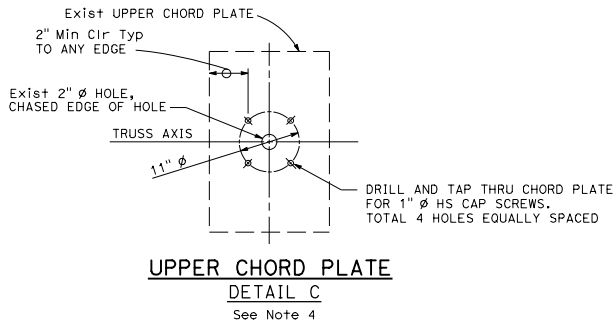
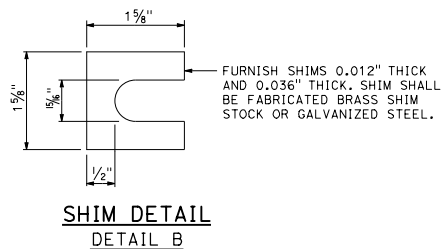
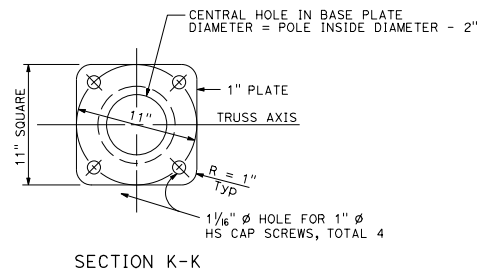
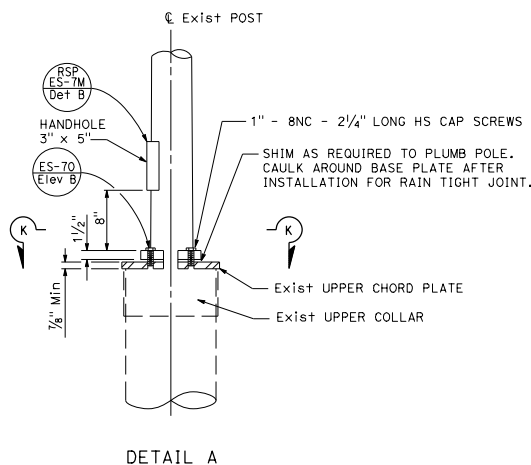
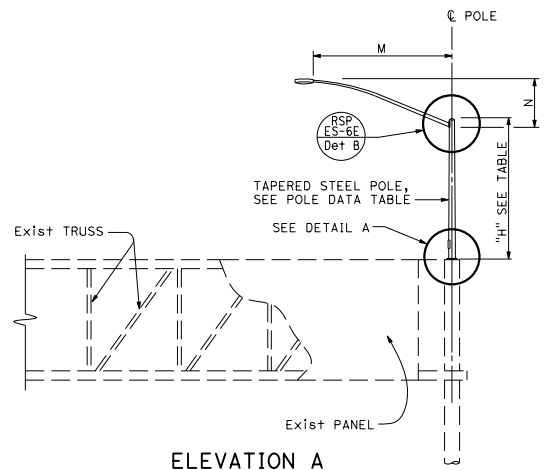

STATE OF CALIFORNIA
 DEPARTMENT OF TRANSPORTATION
**ELECTRICAL SYSTEMS
 (LIGHTING STANDARD,
 TYPES 5 AND 10,
 OVERHEAD SIGN MOUNTED)**
 NO SCALE

RSP ES-6C DATED APRIL 20, 2018 SUPERSEDES RSP ES-6C DATED JULY 15, 2016 AND STANDARD PLAN ES-6C DATED OCTOBER 30, 2015 - PAGE 451 OF THE STANDARD PLANS BOOK DATED 2015.

REVISED STANDARD PLAN RSP ES-6C

2015 REVISED STANDARD PLAN RSP ES-6C

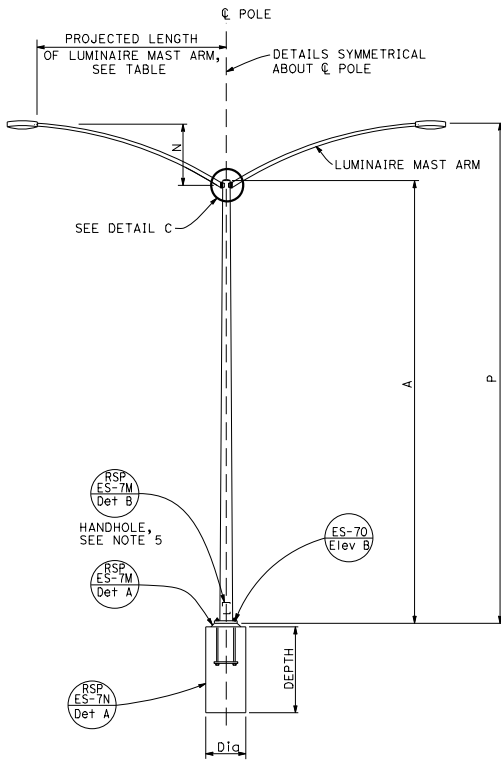

TYPE 15D AND TYPE 21D
ELEVATION A

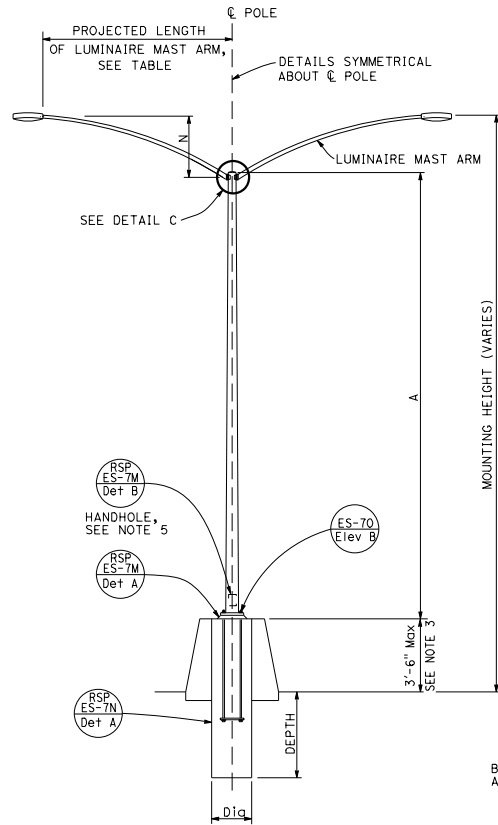

TYPE 15D AND TYPE 21D
MEDIAN BARRIER MOUNTED
ELEVATION B

POLE TYPE	POLE DATA				BASE PLATE DATA			CIDH PILE FOUNDATION	
	A HEIGHT	Min OD	Min THICKNESS	C	BC = BOLT CIRCLE	THICKNESS	ANCHOR BOLT SIZE	Di _g	DEPTH
15D	30'-0"	8"	0.1793"	1'-0"	1'-0"	1/2"	1 1/4" ø x 42"	2'-6"	7'-0"
21D	35'-0"	8 5/8"	3 1/8"						

LUMINAIRE MAST ARM DATA					
PROJECTED LENGTH	N RISE	Min OD AT POLE	NOMINAL THICKNESS	P	
				TYPE 15D	TYPE 21D
6'-0"	2'-0"±	3 1/4"	0.1196"	31'-6"±	36'-6"±
8'-0"	2'-6"±	3 1/2"		32'-0"±	37'-0"±
10'-0"	3'-3"±	3 3/8"		32'-9"±	37'-9"±
12'-0"	4'-3"±			33'-9"±	38'-9"±

NOTES:

1. [] Indicates mast arm length to be used unless otherwise noted on the plans.
2. For additional notes and details, see Revised Standard Plans RSP ES-7M and RSP ES-7N.
3. See Concrete Barrier Details Type 60MF and 60MSF.
4. For locations with one arm, plug unused cap screw holes and chased outlet with galvanized cap screws and knockout plug.
5. Handhole shall be located perpendicular to the luminaire mast arm and as directed by the Engineer.

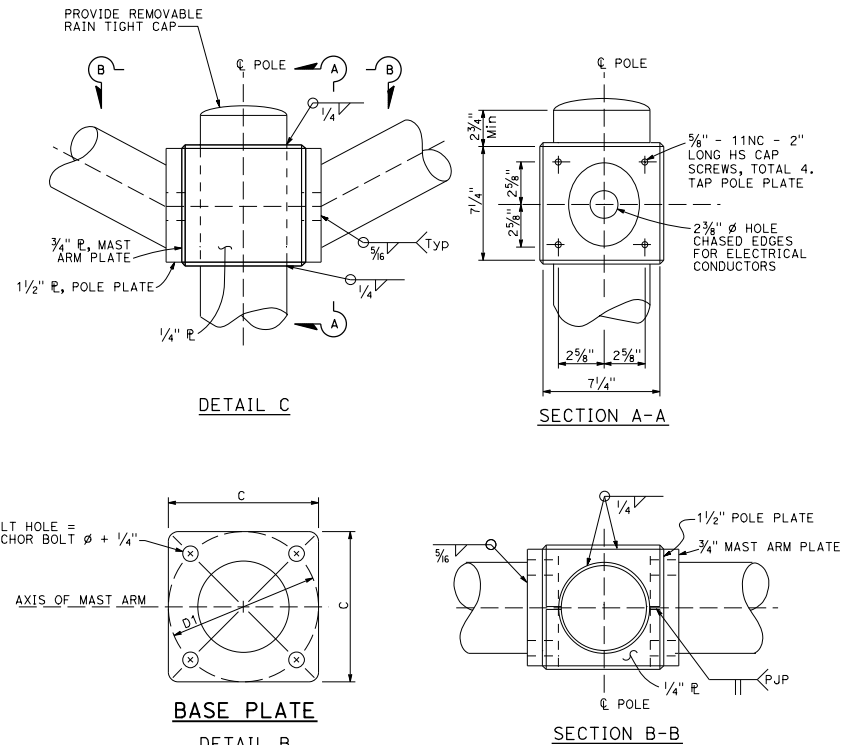

BASE PLATE
DETAIL B

SECTION B-B

STATE OF CALIFORNIA
DEPARTMENT OF TRANSPORTATION
ELECTRICAL SYSTEMS
(LIGHTING STANDARD,
TYPES 15D AND 21D,
DOUBLE LUMINAIRE MAST ARM)
NO SCALE

RSP ES-6D DATED APRIL 20, 2018 SUPERSEDES RSP ES-6D DATED JULY 21, 2017
AND RSP ES-6D DATED JULY 15, 2016 AND STANDARD PLAN ES-6D
DATED OCTOBER 30, 2015 - PAGE 452 OF THE STANDARD PLANS BOOK DATED 2015.

REVISED STANDARD PLAN RSP ES-6D

DIST	COUNTY	ROUTE	POST MILES TOTAL PROJECT	SHEET TOTAL SHEETS

Stanley P. Johnson
REGISTERED CIVIL ENGINEER
No. CS7193
EXPIRES 3-31-20
CIVIL
STATE OF CALIFORNIA

APPROVAL DATE: April 20, 2018
PLANS APPROVAL DATE: _____
THE STATE OF CALIFORNIA OR ITS OFFICERS OR AGENTS SHALL NOT BE RESPONSIBLE FOR THE ACCURACY OR COMPLETENESS OF SCANNED COPIES OF THIS PLAN SHEET.

TO ACCOMPANY PLANS DATED _____

2015 REVISED STANDARD PLAN RSP ES-6D

DIST	COUNTY	ROUTE	POST MILES TOTAL PROJECT	SHEET TOTAL NO. SHEETS

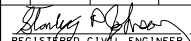
 REGISTERED CIVIL ENGINEER
 No. CS7193
 Exp. 3-31-18
 CIVIL
 STATE OF CALIFORNIA

July 21, 2017
 PLANS APPROVAL DATE
 THE STATE OF CALIFORNIA OR ITS OFFICERS OR AGENTS SHALL NOT BE RESPONSIBLE FOR THE ACCURACY OR COMPLETENESS OF SCANNED COPIES OF THIS PLAN SHEET.

TO ACCOMPANY PLANS DATED _____

NOTES:

- For slip base plate details, see Standard Plan ES-6F.
- For Type 30 fixed base use Type 15 base plate and foundation shown on Revised Standard Plan RSP ES-6A. Use 1/4" Dia x 3'-6" anchor bolts.
- For Type 31 fixed base use Type 32 base plate, anchor bolts and foundation on Revised Standard Plan RSP ES-6G.
- Handhole shall be located on the downstream side of traffic.
- For additional notes and details, see Revised Standard Plans RSP ES-7M and RSP ES-7N.

PROJECTED LENGTH	THICKNESS	MINIMUM OD AT POLE	MOUNTING HEIGHT
* 6'-0"	0.1196"	3 1/4"	36'-9"±
* 8'-0"		3 1/2"	37'-3"±
* 10'-0"		3 3/8"	38'-0"±
* 12'-0"		3 7/8"	39'-0"±
* 15'-0"	4 1/4"	39'-6"±	
** 20'-0"	0.1793"	5"	37'-0"±

* TYPE 30
** TYPE 31

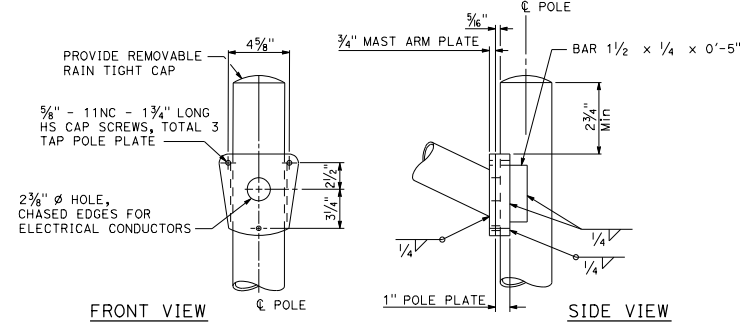

**TYPE 30
DETAIL A**

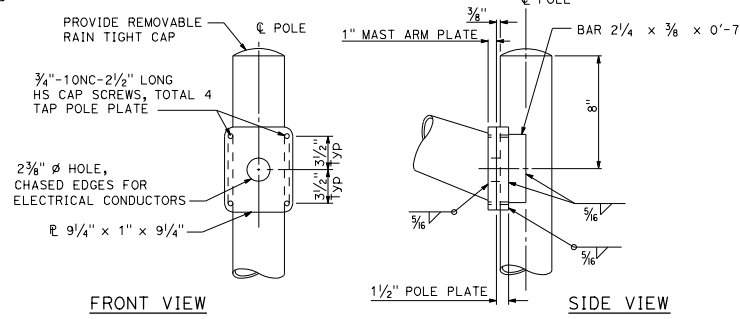

**TYPE 31
DETAIL B**

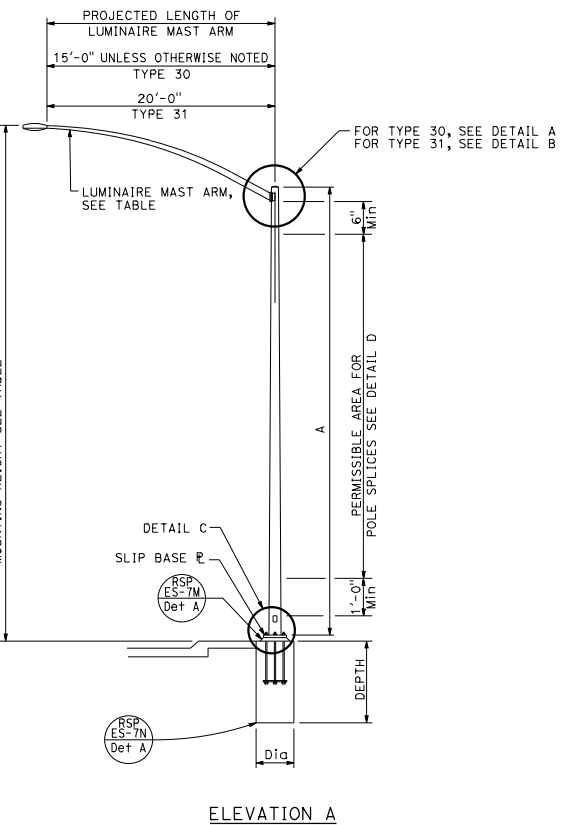

ELEVATION A

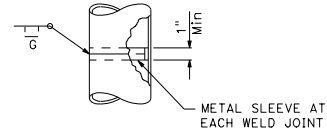

**POLE SPLICE
DETAIL D**

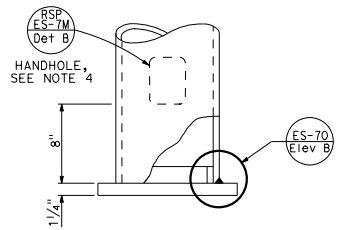

DETAIL C

POLE TYPE	POLE DATA				CIDH PILE FOUNDATION	
	A HEIGHT	Min OD BASE	Min OD TOP	Min THICKNESS	Dia	DEPTH
30	35'-0"	8 3/4"	3 1/8"	0.1196"	2'-6"	7'-0"
31		10 3/4"	5 1/8"	0.1793"	3'-0"	8'-0"

STATE OF CALIFORNIA
DEPARTMENT OF TRANSPORTATION
**ELECTRICAL SYSTEMS
(LIGHTING STANDARD,
TYPES 30 AND 31)**

NO SCALE

RSP ES-6E DATED JULY 21, 2017 SUPERSEDES RSP ES-6E DATED JULY 15, 2016 AND STANDARD PLAN ES-6E DATED OCTOBER 30, 2015 - PAGE 453 OF THE STANDARD PLANS BOOK DATED 2015.

REVISED STANDARD PLAN RSP ES-6E

2015 REVISED STANDARD PLAN RSP ES-6E

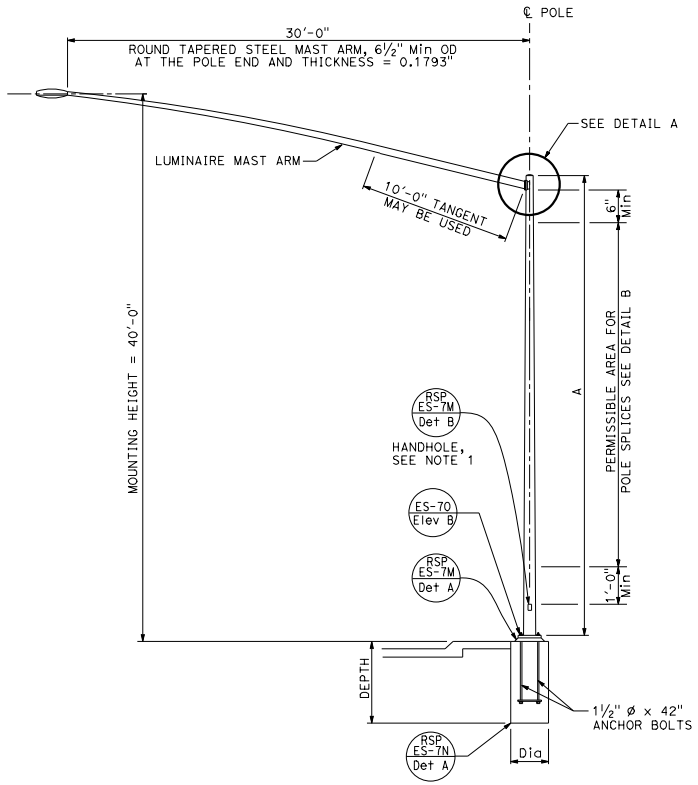

ELEVATION A

POLE TYPE	POLE DATA				BASE PLATE DATA				CIDH PILE FOUNDATION	
	A HEIGHT	Min OD BASE	TOP	Min THICKNESS	C	BC = BOLT CIRCLE	THICKNESS	ANCHOR BOLT SIZE	Diα	DEPTH
32	35'-0"	10 3/4"	5 1/8"	0.1793"	1'-5"	1'-3"	2"	1 1/2" φ x 42"	3'-0"	8'-0"

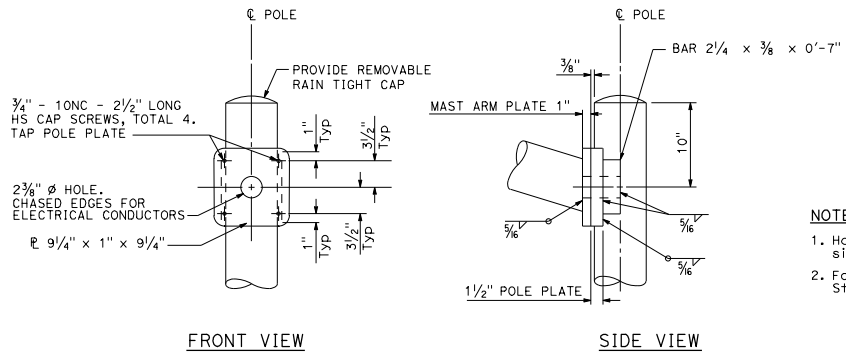

FRONT VIEW

SIDE VIEW

DETAIL A

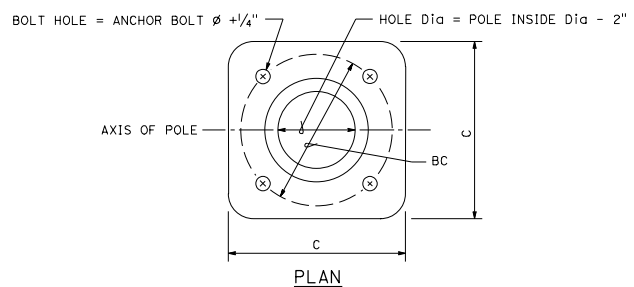

BASE PLATE DETAIL
DETAIL C

DIST	COUNTY	ROUTE	POST MILES TOTAL PROJECT	SHEET TOTAL SHEETS

Stanley P. Johnson
REGISTERED CIVIL ENGINEER
No. CS7193
Exp. 3-31-18
CIVIL
STATE OF CALIFORNIA

PLANS APPROVAL DATE
July 21, 2017

THE STATE OF CALIFORNIA OR ITS OFFICERS OR AGENTS SHALL NOT BE RESPONSIBLE FOR THE ACCURACY OR COMPLETENESS OF SCANNED COPIES OF THIS PLAN SHEET.

TO ACCOMPANY PLANS DATED _____

NOTES:

1. Handhole shall be located on the downstream side of traffic.
2. For additional notes and details, see Revised Standard Plans RSP ES-7M and RSP ES-7N.

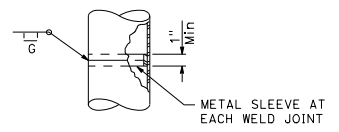

POLE SPLICE
DETAIL B

STATE OF CALIFORNIA
DEPARTMENT OF TRANSPORTATION
**ELECTRICAL SYSTEMS
(LIGHTING STANDARD,
TYPE 32)**

NO SCALE

RSP ES-66 DATED JULY 21, 2017 SUPERSEDES RSP ES-66 DATED JULY 15, 2016 AND STANDARD PLAN ES-66 DATED OCTOBER 30, 2015 - PAGE 455 OF THE STANDARD PLANS BOOK DATED 2015.

REVISED STANDARD PLAN RSP ES-6G

2015 REVISED STANDARD PLAN RSP ES-6G

NOTES:

1. For additional notes, details and data for Type 15TS and Type 21TS Standards, see Revised Standard Plan RSP ES-6A.
2. Handhole shall be located on the downstream side of traffic.

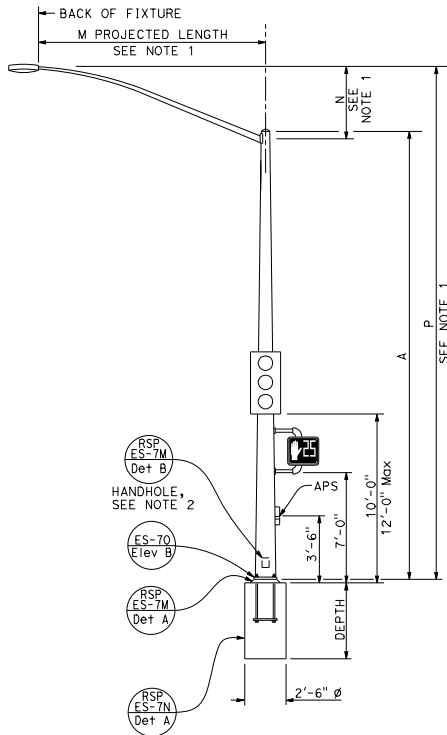

TYPE 15TS AND 21TS STANDARD
ELEVATION A
(See Note 1)

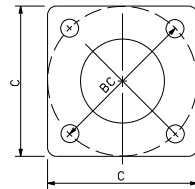

BASE PLATE
TYPE 15TS AND 21TS
DETAIL A

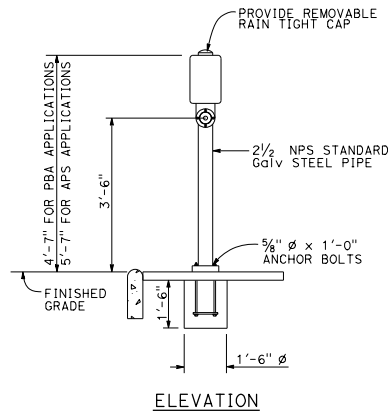

PUSH BUTTON ASSEMBLY POST
DETAIL B

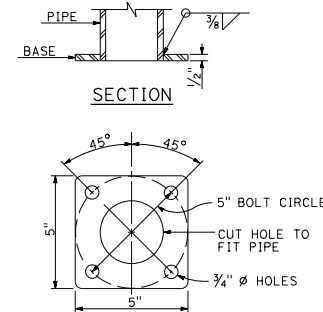

BASE PLATE
PBA POST

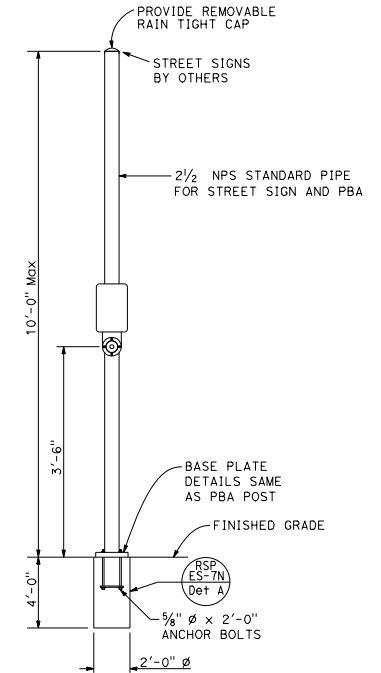

COMBINED STREET SIGN
PUSH BUTTON ASSEMBLY POST
DETAIL C

POLE TYPE	POLE DATA			WALL THICKNESS	BASE PLATE DATA			CIDH
	A HEIGHT	Min OD BASE	TOP		C	BC = BOLT CIRCLE	THICKNESS	
15TS	30'-0"	8"	3 1/8"	0.1793"	1'-1 1/2"	1'-0"	2"	1 1/2" Ø x 42"
21TS	35'-0"	9 3/8"	3 3/8"		1'-3"	1'-2"		

STATE OF CALIFORNIA
DEPARTMENT OF TRANSPORTATION
ELECTRICAL SYSTEMS
(SIGNAL AND LIGHTING STANDARD, TYPE TS,
AND PUSH BUTTON ASSEMBLY POST)

NO SCALE

RSP ES-7A DATED JULY 21, 2017 SUPERSEDES RSP ES-7A DATED JULY 15, 2016 AND STANDARD PLAN ES-7A DATED OCTOBER 30, 2015 - PAGE 456 OF THE STANDARD PLANS BOOK DATED 2015.

REVISED STANDARD PLAN RSP ES-7A

2015 REVISED STANDARD PLAN RSP ES-7A

Dist	COUNTY	ROUTE	POST MILES TOTAL PROJECT	SHEET TOTAL SHEETS

Stanley P. Johnson
REGISTERED CIVIL ENGINEER

July 21, 2017
PLANS APPROVAL DATE

Stanley P. Johnson
No. CS7193
REG. PROFESSIONAL ENGINEER
No. 3-31-18
CIVIL
STATE OF CALIFORNIA

THE STATE OF CALIFORNIA OR ITS OFFICERS OR AGENTS SHALL NOT BE RESPONSIBLE FOR THE ACCURACY OR COMPLETENESS OF SCANNED COPIES OF THIS PLAN SHEET.

TO ACCOMPANY PLANS DATED _____

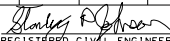
Dist	COUNTY	ROUTE	POST MILES TOTAL PROJECT	SHEET TOTAL NO. SHEETS
 REGISTERED CIVIL ENGINEER No. CS7193 Exp. 3-31-18 CIVIL STATE OF CALIFORNIA				
July 15, 2016 PLANS APPROVAL DATE THE STATE OF CALIFORNIA OR ITS OFFICERS OR AGENTS SHALL NOT BE RESPONSIBLE FOR THE ACCURACY OR COMPLETENESS OF SCANNED COPIES OF THIS PLAN SHEET.				

TO ACCOMPANY PLANS DATED _____

NOTES:

- Standards shall be 10'-0" ± 2" for vehicle signals and 7'-0" ± 2" for pedestrian signals unless shorter pole is noted on project plans.
- Top of standards shall be 4 1/2" OD.
- Conduits shall extend 2" maximum above finished surface of foundation and for Types 1-A, 1-C and 1-D shall be sloped toward handhole.
- Anchor bolts shall be bonded to conduit or grounding conductor.
- For additional notes and details, see Revised Standard Plans RSP ES-7M and RSP ES-7N.
- Pour foundation concrete against undisturbed soil.
- For standards with handhole, locate in the downstream side of traffic.
- Coupling nuts to be used only when shown or specified on project plans.

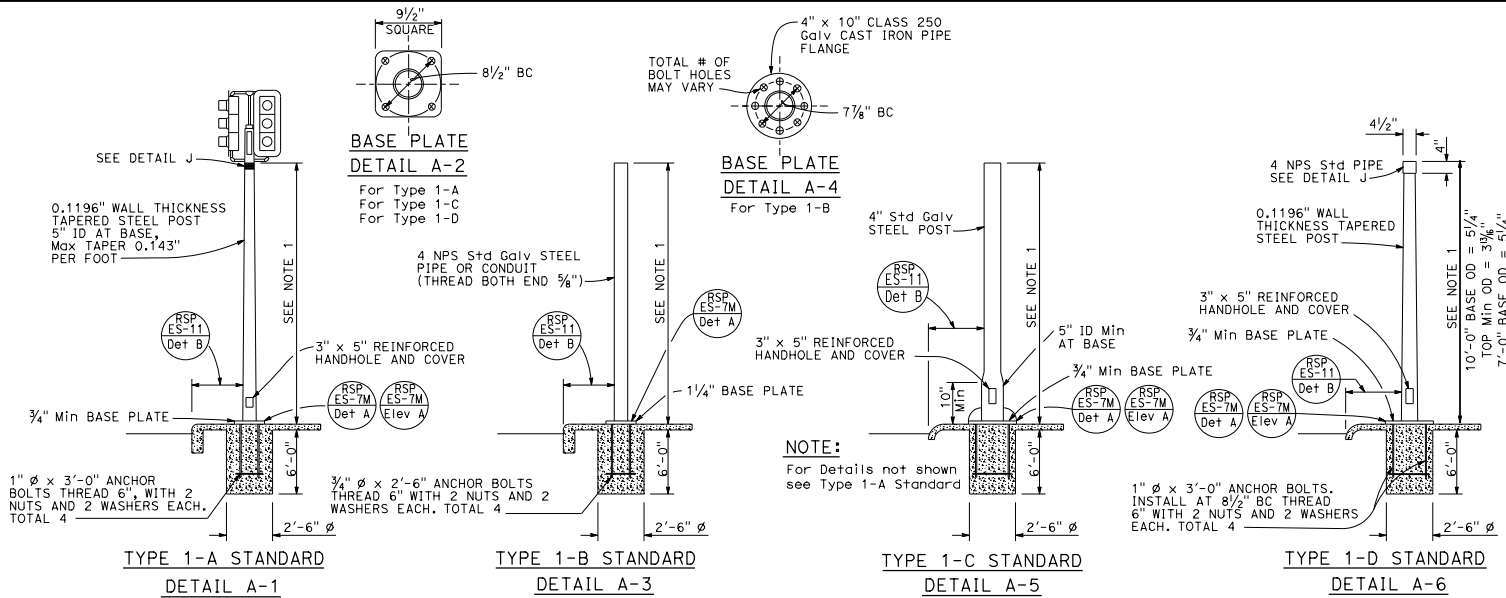

**TYPE 1 SIGNAL STANDARDS
DETAIL A**

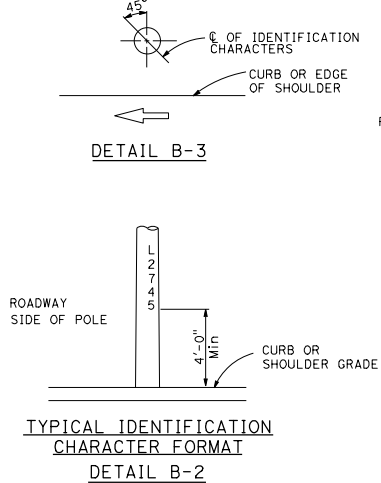
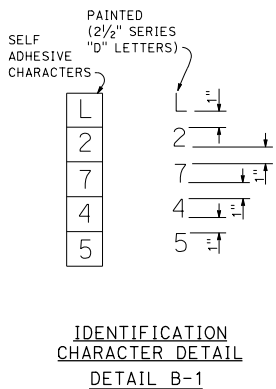

**LOCATION OF EQUIPMENT IDENTIFICATION CHARACTERS
ON STANDARDS AND POSTS
DETAIL B**

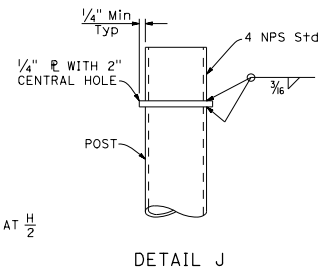
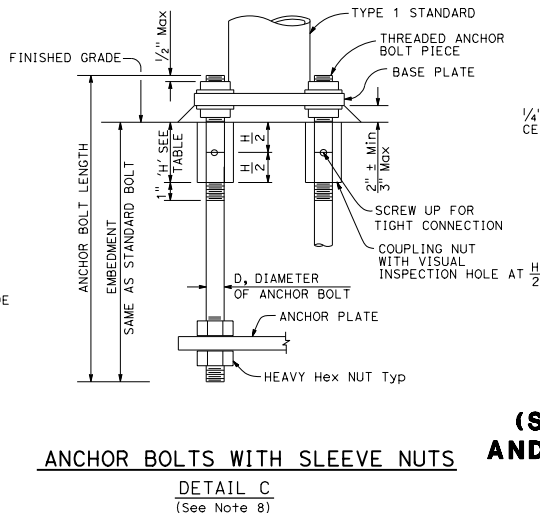

BOLT DIAMETER	NUT TABLE THICKNESS 'H'
3/4"	2 1/4"
1"	3"

**ELECTRICAL SYSTEMS
(SIGNAL AND LIGHTING STANDARD, TYPE 1
AND EQUIPMENT IDENTIFICATION CHARACTERS)**

NO SCALE

RSP ES-7B DATED JULY 15, 2016 SUPERSEDES STANDARD PLAN ES-7B
DATED OCTOBER 30, 2015 - PAGE 457 OF THE STANDARD PLANS BOOK DATED 2015.

REVISED STANDARD PLAN RSP ES-7B

2015 REVISED STANDARD PLAN RSP ES-7B

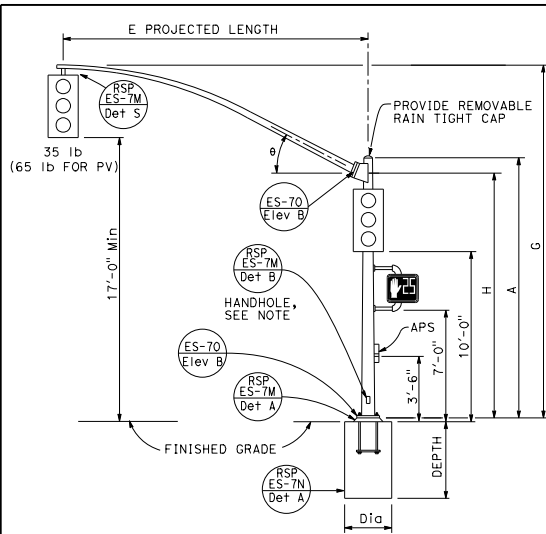

TYPE 16-1-100, 18-1-100
ELEVATION A

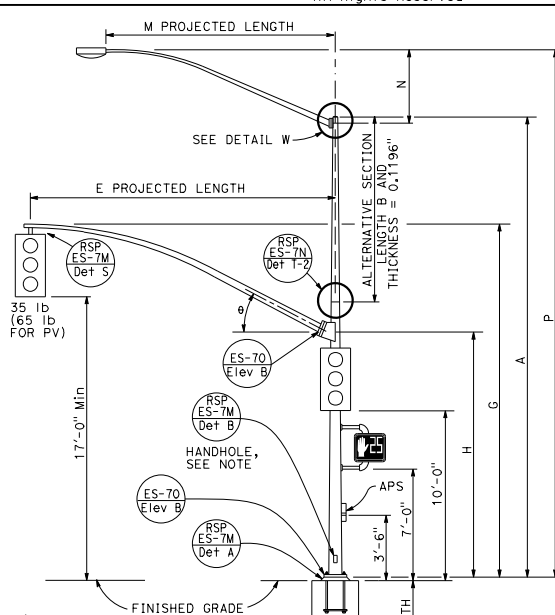

TYPE 19-1-100, 19A-1-100
ELEVATION B

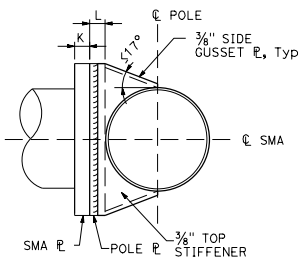

SECTION B-B

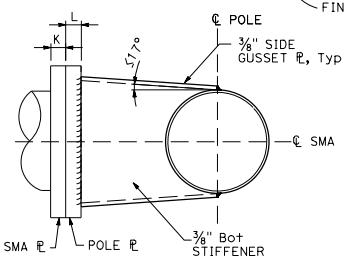

SECTION C-C

SIGNAL MAST ARM DATA										
E PROJECTED LENGTH	G MOUNTING HEIGHT	H	Min OD AT POLE	THICKNESS	I BOLT CIRCLE	HS CAP SCREWS	J PLATE SIZE	K MAST ARM R THICKNESS	L POLE R THICKNESS	θ
15'-0"	21'-8"±	17'-6"	7 3/8"	0.1793"	12"	1 1/4"-7NC-3"	1'-0"	1 1/4"	1 1/2"	23°
20'-0"	21'-8"±	17'-6"	8"							
25'-0"	22'-8"±	16'-0"	9"							
30'-0"	23'-0"±	16'-0"	10"							

LUMINAIRE MAST ARM DATA					
M PROJECTED LENGTH	N RISE	Min OD AT POLE	THICKNESS	P MOUNTING HEIGHT	
				30'-0" POLE	35'-0" POLE
6'-0"	2'-0"±	3 1/4"	0.1196"	31'-6"±	36'-6"±
8'-0"	2'-6"±	3 1/2"		32'-0"±	37'-0"±
10'-0"	3'-3"±	3 3/8"		32'-9"±	37'-9"±
12'-0"	4'-3"±	3 7/8"		33'-9"±	38'-9"±
15'-0"	4'-9"±	4 1/4"		34'-3"±	39'-3"±

POLE TYPE	LOAD CASE	WIND VELOCITY (mph)	POLE DATA				BASE PLATE DATA				LUMINAIRE MAST ARM	SIGNAL MAST ARM	CIDH PILE FOUNDATION					
			A HEIGHT	Min OD		THICKNESS	ALTERNATIVE SECTION			C			BC = BOLT CIRCLE	THICKNESS	ANCHOR BOLT SIZE	Dia	DEPTH	
				BASE	TOP		B LENGTH	BOTTOM	TOP									
16-1-100	1	100	18'-6"	12"	9 3/8"	0.2391"	None			1'-6"	1'-4"	2"	1 1/4"ø x 42"	NONE	15'-0", [20'-0"]	3'-0"	9'-0"	
18-1-100			17'-0"	12"	9 3/8"	0.2391"	None			1'-6"	1'-4"	2"	1 1/4"ø x 42"	NONE	15'-0", [20'-0"]	3'-0"	9'-0"	
19-1-100			30'-0"	14"	9 3/4"	OR 0.25"	10'-0"	11 1/8"	9 3/4"	9"	1'-10"	1'-8"	2 1/2"	2"ø x 42"	6'-15" [12'-0"]	25'-0", [30'-0"]	3'-6"	10'-0"
19A-1-100			35'-0"	14"	9"	OR 0.25"	15'-0"	11 1/8"	9"	9"	1'-10"	1'-8"	2 1/2"	2"ø x 42"	6'-15" [15'-0"]	25'-0", [30'-0"]	3'-6"	10'-0"

□ INDICATES MAST ARM LENGTH TO BE USED UNLESS OTHERWISE NOTED ON PLANS.

NOTES:

- Handhole shall be located on the downstream side of traffic.
- Δ = Luminaire mast arm skew -90° or +90° default 0°

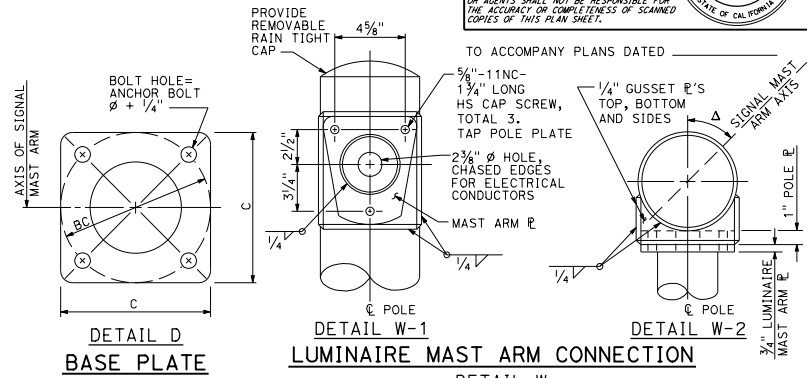

DETAIL D
BASE PLATE

DETAIL W-1
LUMINAIRE MAST ARM CONNECTION

DETAIL W-2
POLE CONNECTION

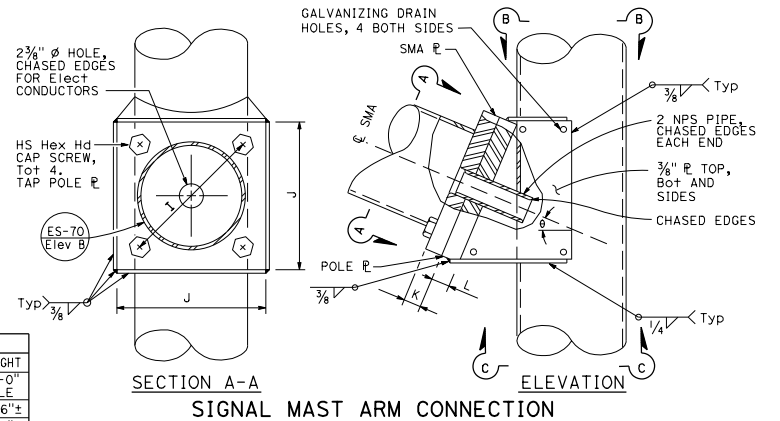

SECTION A-A

SIGNAL MAST ARM CONNECTION

DETAIL A

STATE OF CALIFORNIA
DEPARTMENT OF TRANSPORTATION

ELECTRICAL SYSTEMS (SIGNAL AND LIGHTING STANDARD, CASE 1 SIGNAL MAST ARM LOADING, WIND VELOCITY = 100 MPH AND SIGNAL MAST ARM LENGTHS 15' TO 30')

NO SCALE
RSP ES-7C DATED APRIL 20, 2018 SUPERSEDES RSP ES-7C DATED JULY 21, 2017 AND RSP ES-7C DATED JULY 15, 2016 AND STANDARD PLAN ES-7C DATED OCTOBER 30, 2015 - PAGE 458 OF THE STANDARD PLANS BOOK DATED 2015.

REVISED STANDARD PLAN RSP ES-7C

DIST	COUNTY	ROUTE	POST MILES TOTAL PROJECT	SHEET TOTAL SHEETS

Stanley P. Johnson
REGISTERED CIVIL ENGINEER

April 20, 2018
PLANS APPROVAL DATE

Stanley P. Johnson
No. CS7193
Exp. 3-31-20
CIVIL ENGINEER
STATE OF CALIFORNIA

THE STATE OF CALIFORNIA OR ITS OFFICERS OR AGENTS SHALL NOT BE RESPONSIBLE FOR THE ACCURACY OR COMPLETENESS OF SCANNED COPIES OF THIS PLAN SHEET.

2015 REVISED STANDARD PLAN RSP ES-7C

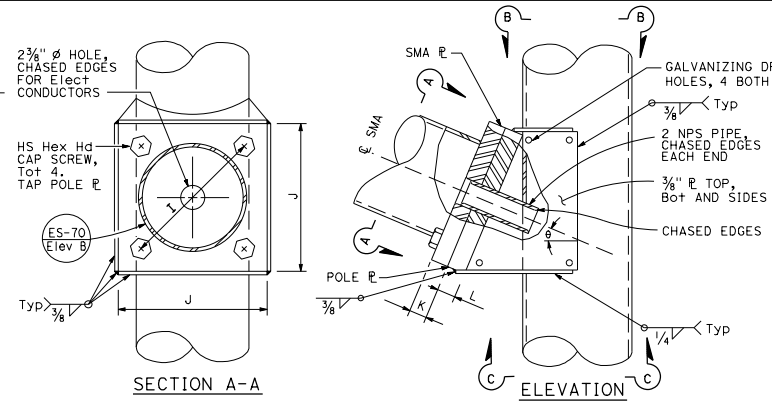
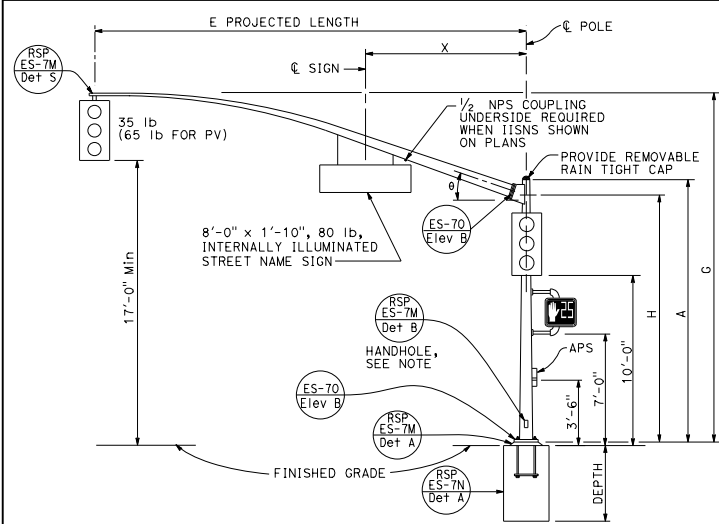

SIGNAL MAST ARM CONNECTION

DETAIL A

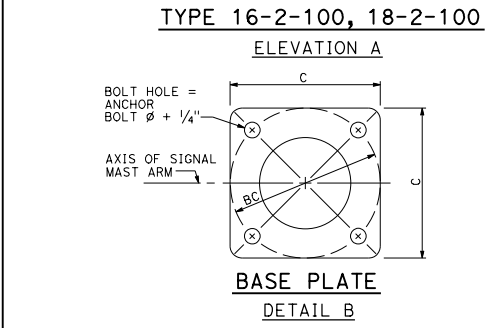

TYPE 16-2-100, 18-2-100

ELEVATION A

BASE PLATE

DETAIL B

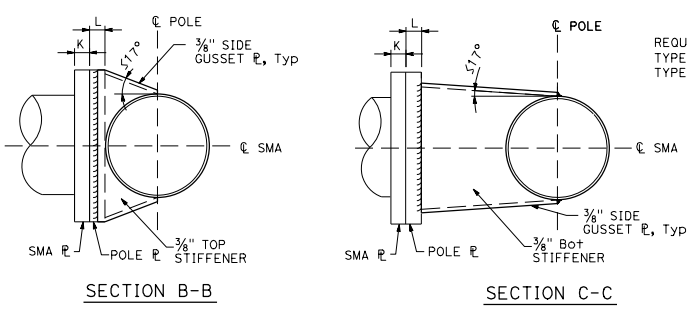

SECTION B-B

SECTION C-C

SIGNAL MAST ARM DATA										
E PROJECTED LENGTH	G MOUNTING HEIGHT	H	Min OD AT POLE	THICKNESS	I BOLT CIRCLE	HS CAP SCREWS	J PLATE SIZE	K MAST ARM THICKNESS	L POLE THICKNESS	θ X Max
15'-0"	21'-8"±	17'-6"	7 3/8"	0.1793"	12"	1 1/4"-7NC-3"	1'-1"	1/4"	1 1/2"	23° 10'-6"
20'-0"	21'-8"±		8"				1'-3"			
25'-0"	22'-8"±	16'-0"	9"							
30'-0"	23'-0"±		10"	0.2391"						

LUMINAIRE MAST ARM DATA					
M PROJECTED LENGTH	N RISE	Min OD AT POLE	THICKNESS	P MOUNTING HEIGHT	
				30'-0" POLE	35'-0" POLE
6'-0"	2'-0"±	3/4"	0.1196"	31'-6"±	36'-6"±
8'-0"	2'-6"±	3/2"		32'-0"±	37'-0"±
10'-0"	3'-3"±	3 3/8"		32'-9"±	37'-9"±
12'-0"	4'-3"±	3 3/8"		33'-9"±	38'-9"±
15'-0"	4'-9"±	4/4"		34'-3"±	39'-3"±

DIST	COUNTY	ROUTE	POST MILES TOTAL PROJECT	SHEET TOTAL SHEETS

Stanley P. Johnson
REGISTERED CIVIL ENGINEER

July 21, 2017
PLANS APPROVAL DATE

Stanley P. Johnson
No. CS7193
Exp. 3-31-18
CIVIL
STATE OF CALIFORNIA

THE STATE OF CALIFORNIA OR ITS OFFICERS OR AGENTS SHALL NOT BE RESPONSIBLE FOR THE ACCURACY OR COMPLETENESS OF SCANNED COPIES OF THIS PLAN SHEET.

NOTE: TO ACCOMPANY PLANS DATED _____
Handhole shall be located on the downstream side of traffic.

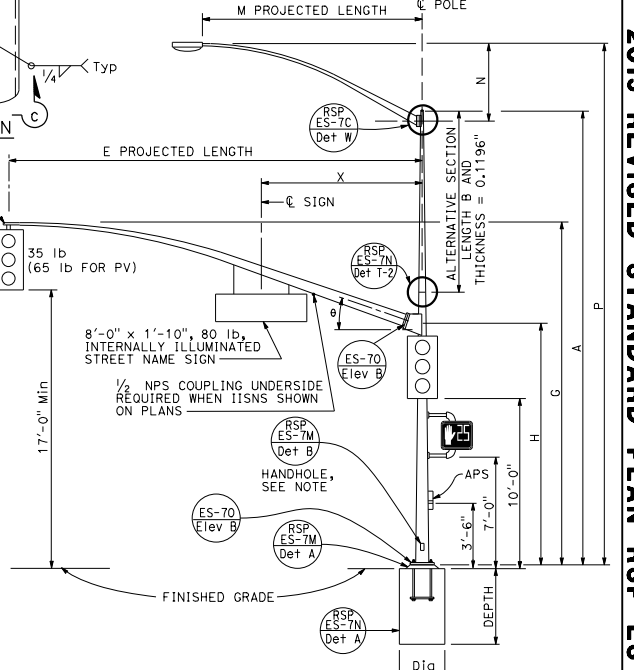

TYPE 17-2-100, 17A-2-100,
19-2-100, 19A-2-100

ELEVATION B

POLE TYPE	LOAD CASE	WIND VELOCITY (mph)	POLE DATA			BASE PLATE DATA				LUMINAIRE MAST ARM	SIGNAL MAST ARM	CIDH PILE FOUNDATION				
			A HEIGHT	Min OD BASE	Min OD TOP	THICKNESS	B LENGTH	TOP	C			BC = BOLT CIRCLE	THICKNESS	ANCHOR BOLT SIZE	Dia	DEPTH
16-2-100	2	100	18'-6"	11 3/8"												
17-2-100			30'-0"	9 3/4"												
17A-2-100			35'-0"	9"	0.2391" OR 0.25"	10'-0"	11 1/8"	9 3/4"	1'-10"	1'-8"	2 1/2"	2" Ø x 42"	6'-15" [2'-0"]	15'-0" [20'-0"]	3'-6"	10'-0"
18-2-100			17'-0"	11 5/8"												
19-2-100			30'-0"	9 3/4"												
19A-2-100			35'-0"	11"												

INDICATES MAST ARM LENGTH TO BE USED UNLESS OTHERWISE NOTED ON PLANS.

STATE OF CALIFORNIA
DEPARTMENT OF TRANSPORTATION
**ELECTRICAL SYSTEMS
(SIGNAL AND LIGHTING STANDARD,
CASE 2 SIGNAL MAST ARM LOADING,
WIND VELOCITY=100 MPH AND SIGNAL
MAST ARM LENGTHS 15' TO 30')**
NO SCALE

RSP ES-7D DATED JULY 21, 2017 SUPERSEDES RSP ES-7D DATED JULY 15, 2016 STANDARD PLAN ES-7D DATED OCTOBER 30, 2015 - PAGE 459 OF THE STANDARD PLANS' BOOK DATED 2015.

REVISED STANDARD PLAN RSP ES-7D

2015 REVISED STANDARD PLAN RSP ES-7D

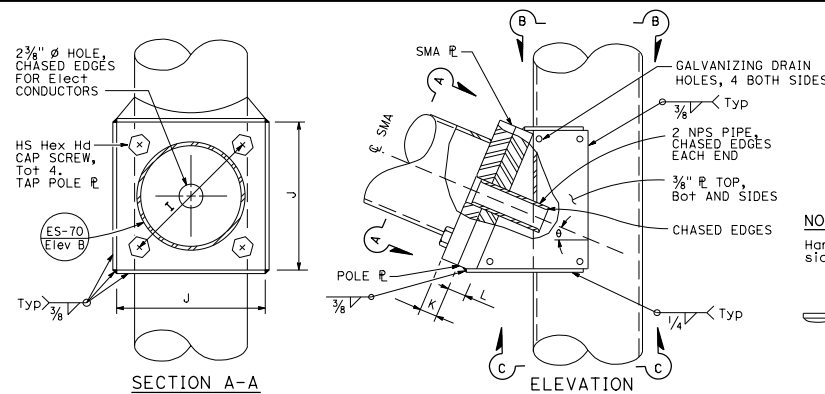
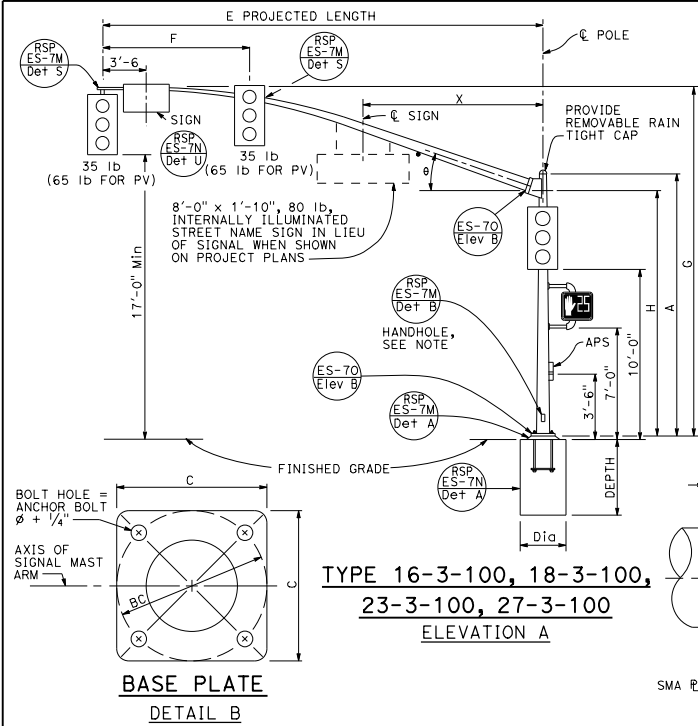

SIGNAL MAST ARM CONNECTION

TYPE 16-3-100, 18-3-100, 23-3-100, 27-3-100
ELEVATION A

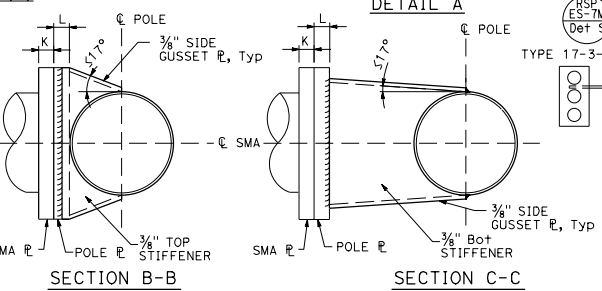

TYPE 17-3-100, 24A-3-100, 19-3-100, 26A-3-100, 24-3-100
ELEVATION B

Dist	COUNTY	ROUTE	POST MILES TOTAL PROJECT	SHEET TOTAL SHEETS

Stanley P. Johnson
REGISTERED CIVIL ENGINEER
No. CS7193
Exp. 3-31-18
CIVIL
STATE OF CALIFORNIA

July 21, 2017
PLANS APPROVAL DATE

THE STATE OF CALIFORNIA OR ITS OFFICERS OR AGENTS SHALL NOT BE RESPONSIBLE FOR THE ACCURACY OR COMPLETENESS OF SCANNED COPIES OF THIS PLAN SHEET.

NOTE:
Handhole shall be located on the downstream side of traffic.

E PROJECTED LENGTH	F Min SPACING	G MOUNTING HEIGHT	H	Min OD AT POLE	THICKNESS	J BOLT CIRCLE	HS CAP SCREWS	J PLATE SIZE	K MAST ARM THICKNESS	L POLE THICKNESS	θ	X Max
15'-0"	8'-0"	21'-8"±	17'-6"	7 7/8"	0.1793"	12"		1'-3"	1 1/4"	1 1/2"	23°	-
20'-0"		21'-8"±		7 7/8"								
25'-0"	12'-0"	22'-8"±		7 7/8"								
30'-0"		22'-8"±		8"								
35'-0"	14'-0"	23'-0"±	16'-0"	8 3/4"	0.2391"		1 1/4"-7NC-3"				21°	10'-6"
40'-0"		23'-0"±		9 5/8"								
45'-0"	15'-0"	23'-8"±		10 1/8"				1'-5"	1 1/2"	1 3/4"	15°	13'-0"

M PROJECTED LENGTH	N RISE	Min OD AT POLE	THICKNESS	P MOUNTING HEIGHT POLE
6'-0"	2'-0"±	3 1/4"	0.1196"	31'-6"± 36'-6"±
8'-0"	2'-6"±	3 1/2"		32'-0"± 37'-0"±
10'-0"	3'-3"±	3 3/4"		32'-9"± 37'-9"±
12'-0"	4'-3"±	3 7/8"		33'-9"± 38'-9"±
15'-0"	4'-9"±	4 1/4"		34'-3"± 39'-3"±

POLE TYPE	LOAD CASE	WIND VELOCITY (mph)	POLE DATA			BASE PLATE DATA			ANCHOR BOLT SIZE	LUMINAIRE MAST ARM	SIGNAL MAST ARM	CIDH PILE FOUNDATION	
			A HEIGHT	Min OD BASE	Min OD TOP	THICKNESS	ALTERNATIVE SECTION B LENGTH	ALTERNATIVE SECTION TOP				C	BOLT CIRCLE
16-3-100			18'-6"		13 7/8"					NONE	15'-0"		
17-3-100			30'-0"		11 3/4"					6'-15' [12'-0"]	[20'-0"]		
18-3-100			17'-0"		13 7/8"	0.2391" OR 0.25"				NONE			
19-3-100			30'-0"		11 3/4"					6'-15' [12'-0"]	25'-0"		12'-0"
19A-3-100			35'-0"	16"	11"	0.3125"				6'-15' [15'-0"]	[30'-0"]		
23-3-100			17'-0"		13 7/8"	0.2391" OR 0.25"				NONE			
24-3-100			30'-0"		11 3/4"					6'-15' [12'-0"]	35'-0"		
24A-3-100			35'-0"		11"					6'-15' [15'-0"]			
26-3-100			30'-0"		13 3/4"	0.3125"				6'-15' [12'-0"]			
26A-3-100			35'-0"	18"	13"					6'-15' [15'-0"]	40'-0"		
27-3-100			17'-0"		15 5/8"					6'-15' [15'-0"]	[45'-0"]		13'-0"

INDICATES MAST ARM LENGTH TO BE USED UNLESS OTHERWISE NOTED ON PLANS.

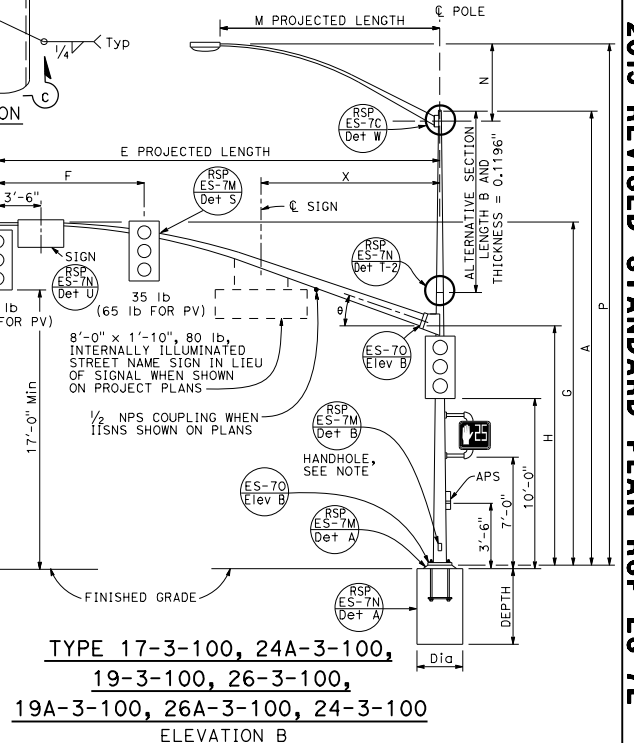

STATE OF CALIFORNIA
DEPARTMENT OF TRANSPORTATION
**ELECTRICAL SYSTEMS
(SIGNAL AND LIGHTING STANDARD,
CASE 3 SIGNAL MAST ARM LOADING,
WIND VELOCITY=100 MPH AND SIGNAL
MAST ARM LENGTHS 15' TO 45')**

NO SCALE
RSP ES-7E DATED JULY 21, 2017 SUPERSEDES RSP ES-7E DATED JULY 15, 2016 AND STANDARD PLAN ES-7E DATED OCTOBER 30, 2015 - PAGE 460 OF THE STANDARD PLANS BOOK DATED 2015.

REVISED STANDARD PLAN RSP ES-7E

2015 REVISED STANDARD PLAN RSP ES-7E

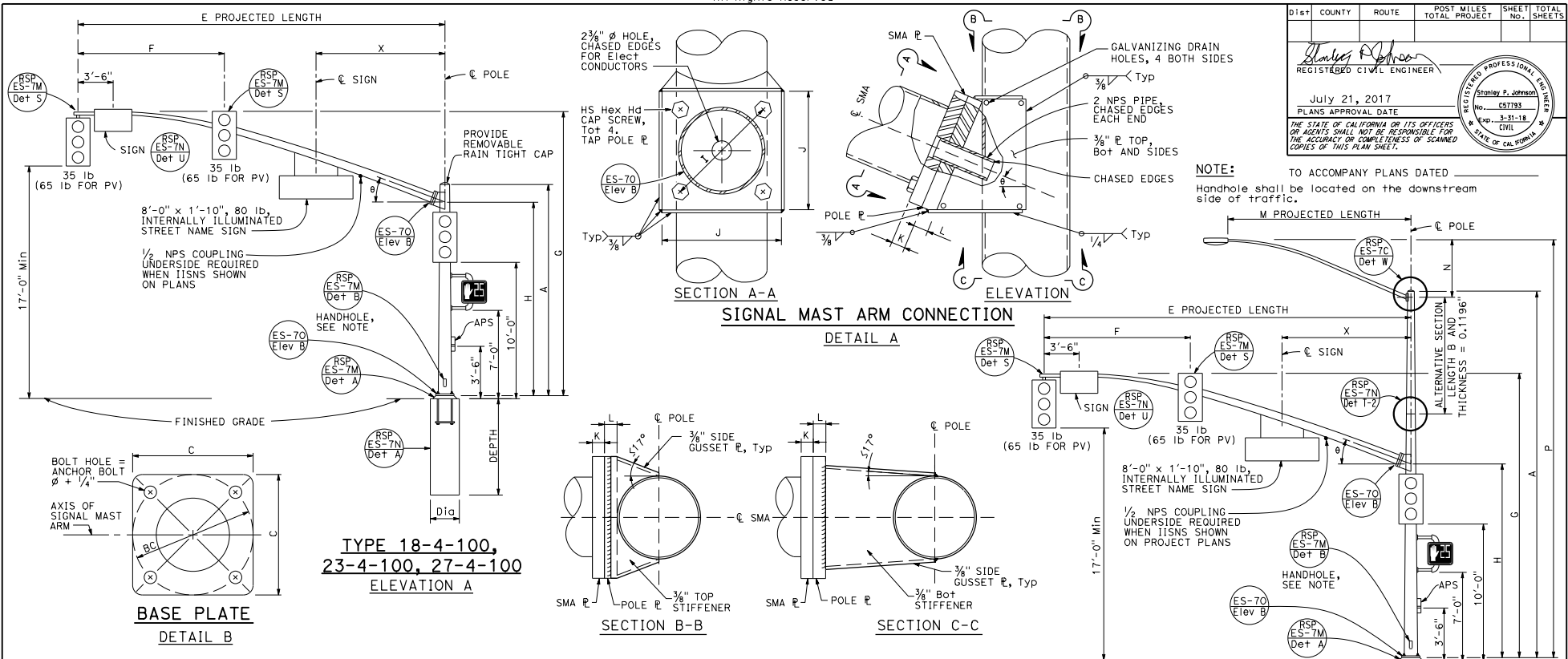

Dist	COUNTY	ROUTE	POST MILES TOTAL PROJECT	SHEET TOTAL SHEETS

Stanley P. Johnson
REGISTERED CIVIL ENGINEER

July 21, 2017
PLANS APPROVAL DATE

Stanley P. Johnson
No. CS793
Exp. 3-31-18
CIVIL
STATE OF CALIFORNIA

NOTE: TO ACCOMPANY PLANS DATED _____
Handhole shall be located on the downstream side of traffic.

SIGNAL MAST ARM DATA														
E PROJECTED LENGTH	F Min SPACING	G MOUNTING HEIGHT	H	Min OD AT POLE	THICKNESS	I BOLT CIRCLE	HS CAP SCREWS	J PLATE SIZE	K MAST ARM THICKNESS	L POLE THICKNESS	θ	X Max		
25'-0"	10'-0"	22'-8"±		7 3/8"	0.2391"	12"	1 1/4"-7NC-3"	1'-3"	1/4"	1 1/2"	23°	10'-6"		
30'-0"	12'-0"		8"											
35'-0"	14'-0"	23'-0"±	16'-0"	8 1/8"										
40'-0"				9 3/8"										
45'-0"	15'-0"	23'-8"±		10 1/4"						1'-5"	1 1/2"	1 3/4"	15°	13'-0"

LUMINAIRE MAST ARM DATA						
M PROJECTED LENGTH	N RISE	Min OD AT POLE	THICKNESS	P MOUNTING HEIGHT	POLE	HEIGHT
6'-0"	2'-0"±	3 1/4"	0.1196"	30'-0"	35'-0"	
8'-0"	2'-6"±	3 1/2"		31'-6"±	36'-6"±	
10'-0"	3'-3"±	3 3/8"		32'-0"±	37'-0"±	
12'-0"	4'-3"±	4"		32'-9"±	37'-9"±	
15'-0"	4'-9"±	4 1/4"		33'-9"±	38'-9"±	
				34'-3"±	39'-3"±	

POLE TYPE	LOAD CASE	WIND VELOCITY (mph)	POLE DATA					BASE PLATE DATA				LUMINAIRE MAST ARM	SIGNAL MAST ARM	CIDH PILE FOUNDATION			
			A HEIGHT	Min OD		THICKNESS	ALTERNATIVE SECTION			C	BC = BOLT CIRCLE			THICKNESS	ANCHOR BOLT SIZE	DIA	DEPTH
				BASE	TOP		B LENGTH	BOTTOM	TOP								
18-4-100	4	100	17'-0"	13 3/8"	0.2391"	10'-0"	13 3/8"	11 3/4"	1'-11"	1'-9"	3"	2 1/4" x 42"	NONE	25'-0"	12'-0"		
19-4-100			30'-0"	11 3/4"		10'-0"	13 3/8"	11 3/4"					6'-15' 12'-0"	50'-0"			
19A-4-100			35'-0"	11"		15'-0"	13 3/8"	11"					6'-15' 15'-0"				
23-4-100			17'-0"	13 3/8"		10'-0"	15 5/8"	13 3/4"					NONE				
24-4-100			30'-0"	11 3/4"		10'-0"	15 5/8"	13 3/4"					6'-15' 12'-0"	35'-0"			
24A-4-100			35'-0"	11"	15'-0"	13 3/8"	11"	6'-15' 15'-0"									
26-4-100			30'-0"	13 3/4"	10'-0"	15 5/8"	13 3/4"	6'-15' 12'-0"	40'-0"								
26A-4-100			35'-0"	13"	15'-0"	15 5/8"	13"	6'-15' 15'-0"	45'-0"								
27-4-100			17'-0"	15 5/8"	15'-0"	15 5/8"	13"	NONE									

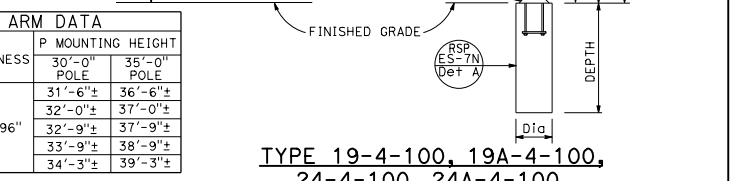

STATE OF CALIFORNIA
DEPARTMENT OF TRANSPORTATION

NO SCALE

**ELECTRICAL SYSTEMS
(SIGNAL AND LIGHTING STANDARD,
CASE 4 SIGNAL MAST ARM LOADING,
WIND VELOCITY=100 MPH AND SIGNAL
MAST ARM LENGTHS 25' TO 45')**

RSP ES-7F DATED JULY 21, 2017 SUPERSEDES RSP ES-7F DATED JULY 15, 2016 AND STANDARD PLAN ES-7F DATED OCTOBER 30, 2015 - PAGE 461 OF THE STANDARD PLANS BOOK DATED 2015.

REVISED STANDARD PLAN RSP ES-7F

INDICATES MAST ARM LENGTH TO BE USED UNLESS OTHERWISE NOTED ON PLANS.

2015 REVISED STANDARD PLAN RSP ES-7F

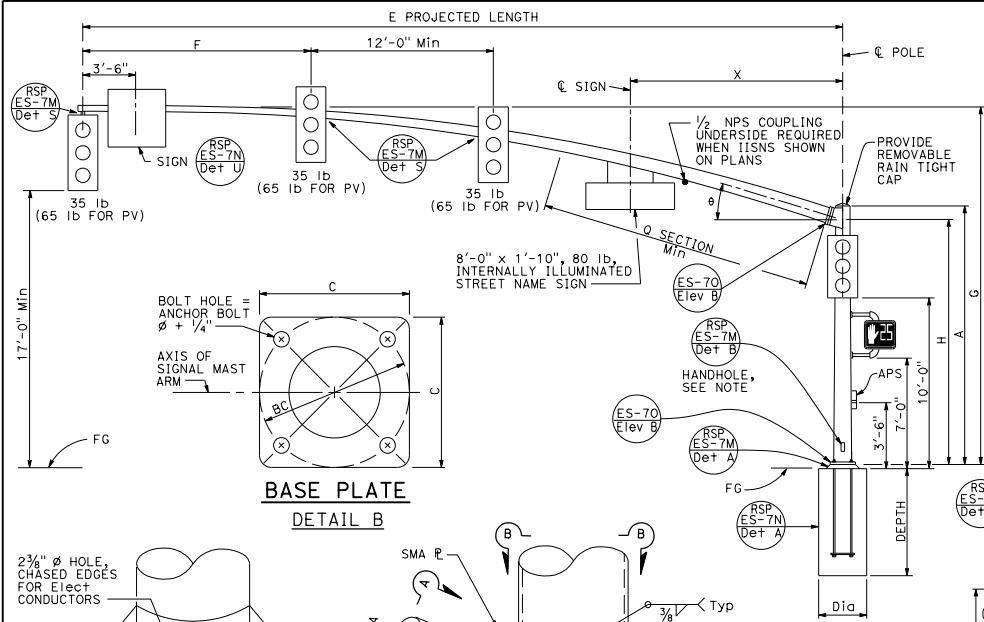

**BASE PLATE
DETAIL B**

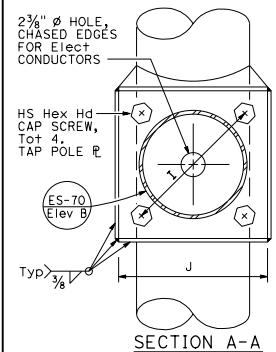

**SIGNAL MAST ARM CONNECTION
DETAIL A**

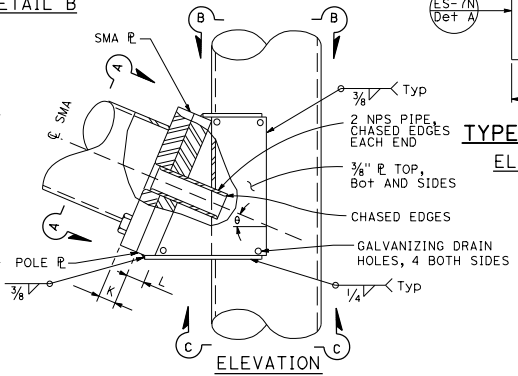

**TYPE 28-5-100
ELEVATION A**

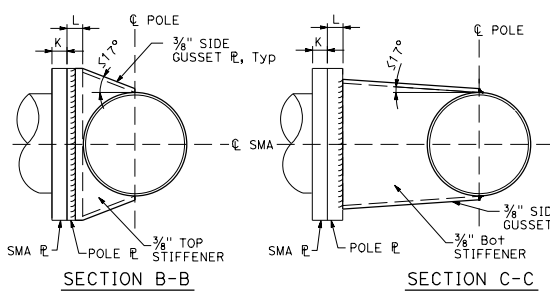

SECTION B-B

SECTION C-C

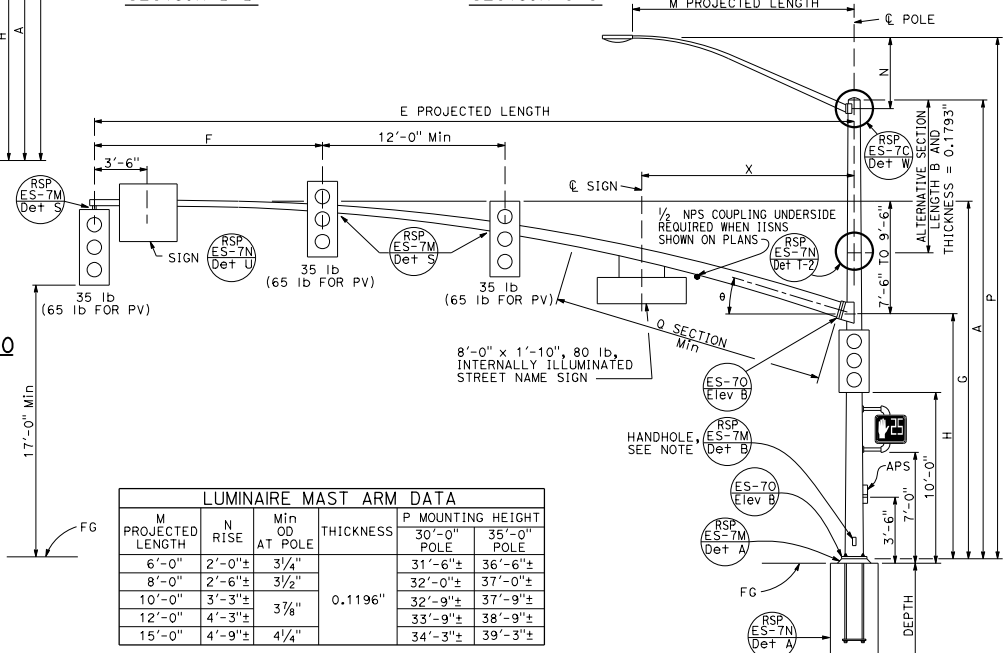

LUMINAIRE MAST ARM DATA					
M PROJECTED LENGTH	N RISE	Min OD AT POLE	THICKNESS	P MOUNTING HEIGHT	
				30'-0" POLE	35'-0" POLE
6'-0"	2'-0"±	3/4"	0.1196"	31'-6"±	36'-6"±
8'-0"	2'-6"±	3/2"		32'-0"±	37'-0"±
10'-0"	3'-3"±	3 3/8"		32'-9"±	37'-9"±
12'-0"	4'-3"±	3 7/8"		33'-9"±	38'-9"±
15'-0"	4'-9"±	4 1/4"		34'-3"±	39'-3"±

**TYPE 29-5-100, 29A-5-100
ELEVATION B**

SIGNAL MAST ARM DATA														
E PROJECTED LENGTH	F Min SPACING	G MOUNTING HEIGHT	H	Min OD AT POLE	THICKNESS	I BOLT CIRCLE	J HS CAP SCREWS	K J PLATE SIZE	L MAST ARM THICKNESS	M POLE R THICKNESS	θ	Q SECTION LENGTH	X Max	
50'-0"	15'-0"	23'-7"± TO 25'-7"±	16'-0"	11 1/8" TO 1'-1/4"	0.1793"	16"	1 1/2"-6NC-3/4"	1'-9"	1 3/4"	1 3/4"	15°	18'-0" TO 23'-0"	0.2391"	14'-0"

POLE TYPE	LOAD CASE	WIND VELOCITY (mph)	POLE DATA				BASE PLATE DATA				LUMINAIRE MAST ARM	SIGNAL MAST ARM	CIDH PILE FOUNDATION		
			A HEIGHT	Min OD BASE	Min OD TOP	THICKNESS	ALTERNATIVE SECTION B LENGTH	TOP	C	BC = BOLT CIRCLE			THICKNESS	ANCHOR BOLT SIZE	DiA
28-5-100	5	100	17'-0"	19 3/8"	0.375"	10'-0"	17 3/4"	2'-6"	2'-4"	3"	2 1/4"φ × 42"	NONE	50'-0"	4'-0"	14'-0"
29-5-100			30'-0"	17 3/4"		15'-0"	19 1/8"	17"							
29A-5-100			35'-0"	17"		15'-0"	17"								

INDICATES MAST ARM LENGTH TO BE USED UNLESS OTHERWISE NOTED ON PLANS.

Dist	COUNTY	ROUTE	POST MILES TOTAL PROJECT	SHEET TOTAL SHEETS

Stanley P. Johnson
REGISTERED CIVIL ENGINEER

July 21, 2017
PLANS APPROVAL DATE

Stanley P. Johnson
No. C57193
Exp. 3-31-18
CIVIL
STATE OF CALIFORNIA

THE STATE OF CALIFORNIA OR ITS OFFICERS OR AGENTS SHALL NOT BE RESPONSIBLE FOR THE ACCURACY OR COMPLETENESS OF SCANNED COPIES OF THIS PLAN SHEET.

TO ACCOMPANY PLANS DATED _____

NOTE:
Handhole shall be located on the downstream side of traffic.

STATE OF CALIFORNIA
DEPARTMENT OF TRANSPORTATION

**ELECTRICAL SYSTEMS
(SIGNAL AND LIGHTING STANDARD,
CASE 5 SIGNAL MAST ARM LOADING,
WIND VELOCITY=100 MPH AND SIGNAL
MAST ARM LENGTHS 50' TO 55')**

NO SCALE

RSP ES-7G DATED JULY 21, 2017 SUPERSEDES RSP ES-7G DATED JULY 15, 2016 AND STANDARD PLAN ES-7G DATED OCTOBER 30, 2015 - PAGE 462 OF THE STANDARD PLANS BOOK DATED 2015.

REVISED STANDARD PLAN RSP ES-7G

2015 REVISED STANDARD PLAN RSP ES-7G

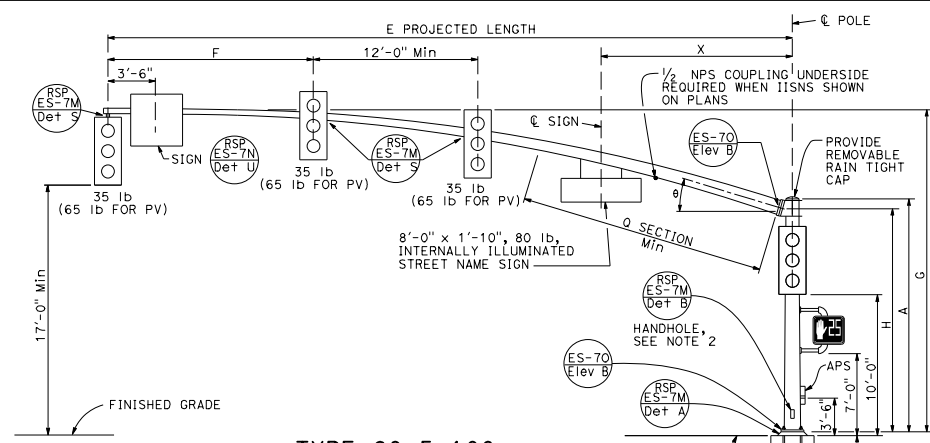

TYPE 60-5-100
ELEVATION A

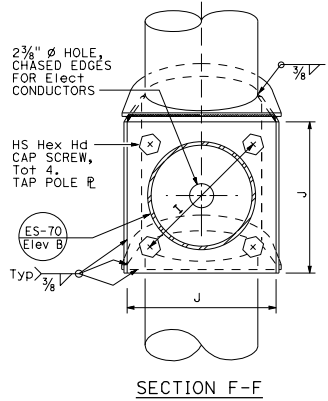

SECTION F-F

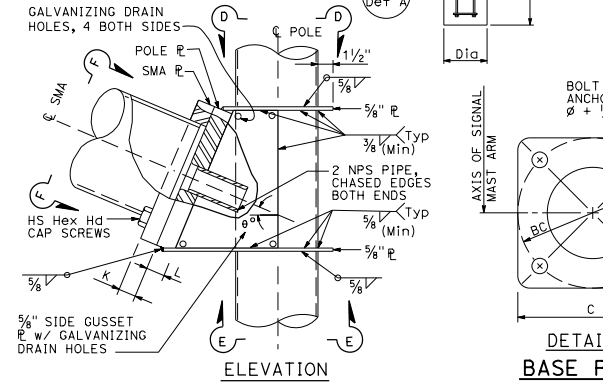

DETAIL B
BASE PLATE

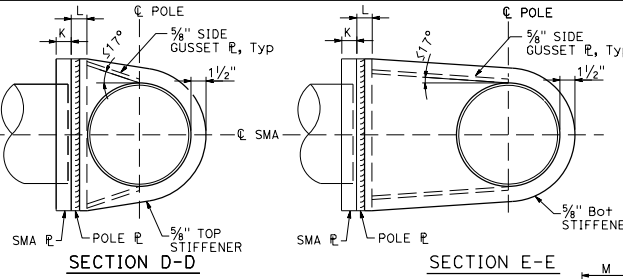

SECTION D-D

SECTION E-E

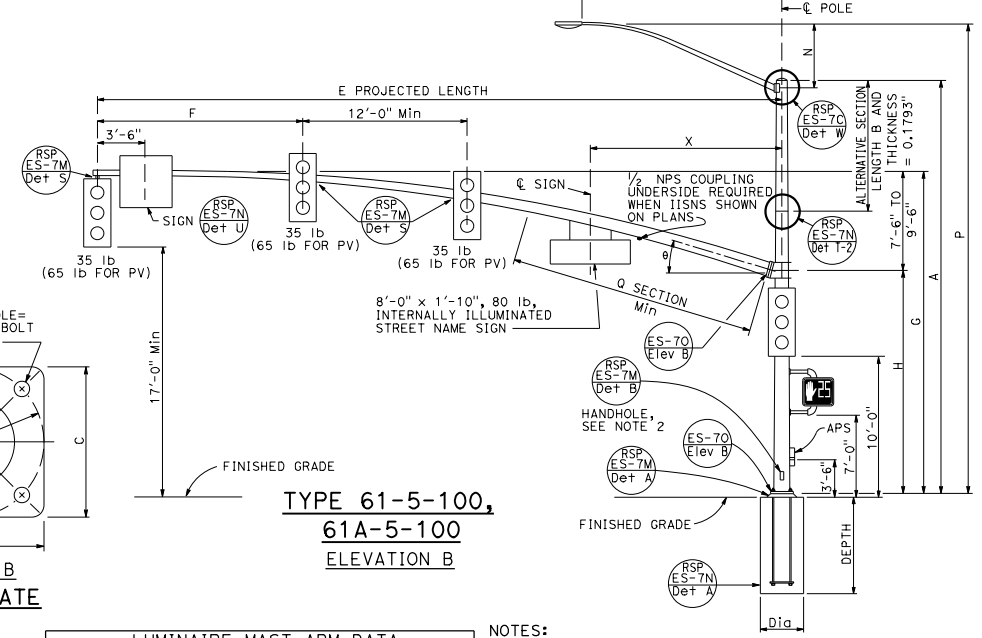

TYPE 61-5-100
61A-5-100
ELEVATION B

SIGNAL MAST ARM DATA													
E PROJECTED LENGTH	F Min SPACING	G MOUNTING HEIGHT	H	Min OD AT POLE	THICKNESS	I BOLT CIRCLE	HS CAP SCREWS	J PLATE SIZE	K MAST ARM THICKNESS	L POLE THICKNESS	Q SECTION LENGTH THICKNESS	X Mgx	
60'-0"	15'-0"	23'-7" TO 25'-7"	16'-0"	1'-1/2"	0.1793" 0.2391"	20"	1 1/2"-6NC-4"	2'-0"	2"	2"	24'-0" 29'-0"	0.2391" 0.3125"	14'-0"

LUMINAIRE MAST ARM DATA					
M PROJECTED LENGTH	N RISE	Min OD AT POLE	THICKNESS	P MOUNTING HEIGHT POLE	POLE
6'-0"	2'-0"±	3/4"	0.1196"	31'-6"±	36'-6"±
8'-0"	2'-6"±	3/2"		32'-0"±	37'-0"±
10'-0"	3'-3"±	3"		32'-9"±	37'-9"±
12'-0"	4'-3"±	3 3/8"		33'-9"±	38'-9"±
15'-0"	4'-9"±	4 1/4"		34'-3"±	39'-3"±

POLE TYPE	LOAD CASE	WIND VELOCITY (mph)	POLE DATA			BASE PLATE DATA				LUMINAIRE MAST ARM	SIGNAL MAST ARM	CIDH PILE FOUNDATION								
			A HEIGHT	Min OD BASE	Min OD TOP	THICKNESS	ALTERNATIVE SECTION B LENGTH	SECTION TOP	C			BC = BOLT CIRCLE	THICKNESS	ANCHOR BOLT SIZE	Dia	DEPTH				
60-5-100	5	100	17'-0"	22"	19 3/8"	0.375"			2'-6"	2'-4"	3"	2 1/4"Ø x 42"	NONE	60'-0"	4'-0"	14'-0"				
61-5-100			30'-0"	25"	20 3/4"		10'-0"	22 1/8"	20 3/4"	2'-11"							2'-9"	3"Ø x 60"	6'-15'	15'-0"
61A-5-100			35'-0"	25"	20"		15'-0"													

□ INDICATES MAST ARM LENGTH TO BE USED UNLESS OTHERWISE NOTED ON PLANS.

DIST	COUNTY	ROUTE	POST MILES TOTAL PROJECT	SHEET TOTAL SHEETS

Stanley P. Johnson
REGISTERED CIVIL ENGINEER
No. 05793
EXPIRES 3-31-18
STATE OF CALIFORNIA

July 21, 2017
PLANS APPROVAL DATE

THE STATE OF CALIFORNIA OR ITS OFFICERS OR AGENTS SHALL NOT BE RESPONSIBLE FOR THE ACCURACY OR COMPLETENESS OF SCANNED COPIES OF THIS PLAN SHEET.

- NOTES:
- The radial separation between the face of the pole and the adjacent insides of the top and bottom gusset plates shall not exceed 3/16". Fillet weld size to be increased by amount of gap.
 - Handhole shall be located on the downstream side of traffic.

STATE OF CALIFORNIA
DEPARTMENT OF TRANSPORTATION
ELECTRICAL SYSTEMS
(SIGNAL AND LIGHTING STANDARD,
CASE 5 SIGNAL MAST ARM LOADING,
WIND VELOCITY=100 MPH AND SIGNAL
MAST ARM LENGTHS 60' TO 65')
NO SCALE

RSP ES-7H DATED JULY 21, 2017 SUPERSEDES RSP ES-7H DATED JANUARY 20, 2017 AND RSP ES-7H DATED JULY 15, 2016 AND STANDARD PLAN ES-7H DATED OCTOBER 30, 2015 - PAGE 463 OF THE STANDARD PLANS BOOK DATED 2015.

REVISED STANDARD PLAN RSP ES-7H

2015 REVISED STANDARD PLAN RSP ES-7H

Dist	COUNTY	ROUTE	POST MILES TOTAL PROJECT	SHEET TOTAL No. SHEETS

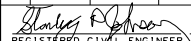

 REGISTERED CIVIL ENGINEER
 No. CS7193
 Exp. 3-31-20
 CIVIL
 STATE OF CALIFORNIA

April 20, 2018
 PLANS APPROVAL DATE
 THE STATE OF CALIFORNIA OR ITS OFFICERS OR AGENTS SHALL NOT BE RESPONSIBLE FOR THE ACCURACY OR COMPLETENESS OF SCANNED COPIES OF THIS PLAN SHEET.

TO ACCOMPANY PLANS DATED _____

NOTES:

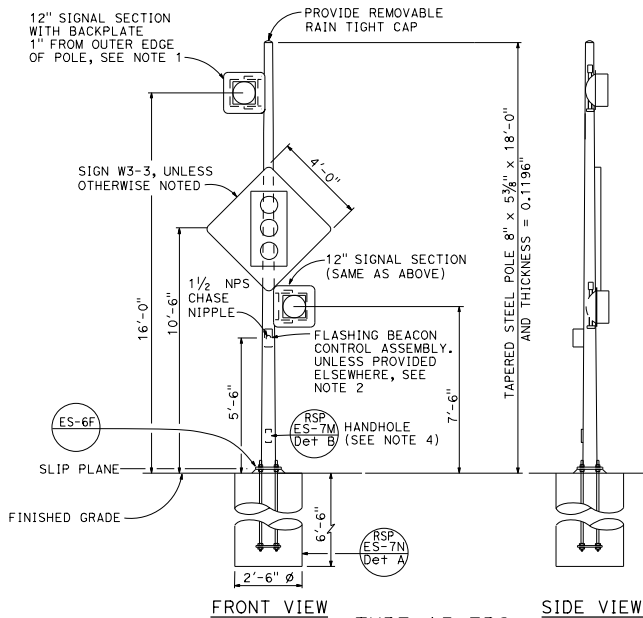
1. See Standard Plans ES-4A and Revised Standard Plan RSP ES-4D for attachment fitting details.
2. For wiring diagram, see Revised Standard Plan RSP ES-14B.
3. For additional notes and details, see Revised Standard Plans RSP ES-7M and RSP ES-7N.
4. Handhole shall be located on the downstream side of traffic.
5. See project plans for type of standard to be installed.



**TYPE 15-FBS
FLASHING BEACON WITH SLIP BASE INSTALLATION
DETAIL A**

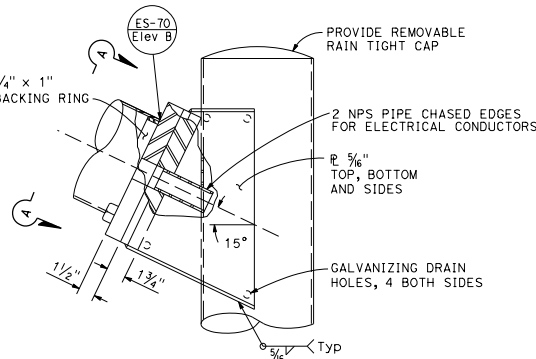

ELEVATION B

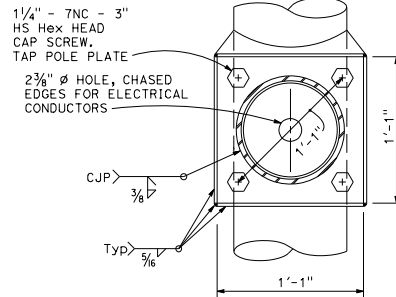

VIEW A-A

**FLASHING BEACON MAST ARM
CONNECTION DETAIL
DETAIL B**

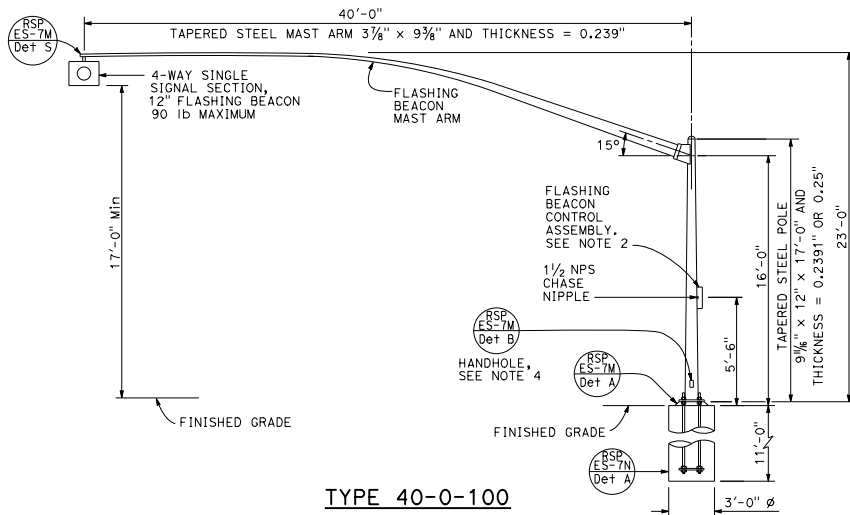

**TYPE 40-0-100
ELEVATION A**

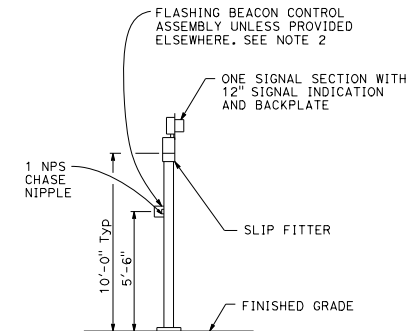

**TYPE 1-A, 1-B, 1-C, AND 1-D
FLASHING BEACON INSTALLATION
DETAIL D**

See Note 5

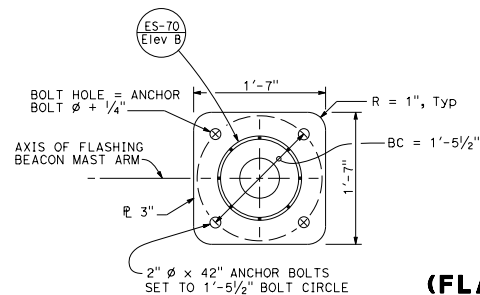

**BASE PLATE
DETAIL C**

STATE OF CALIFORNIA
DEPARTMENT OF TRANSPORTATION
**ELECTRICAL SYSTEMS
(FLASHING BEACON ON A TYPE 1,
TYPE 15-FBS, AND TYPE 40 STANDARD)**

NO SCALE

RSP ES-7J DATED APRIL 20, 2018 SUPERSEDES RSP ES-7J DATED JULY 21, 2017
AND RSP ES-7J DATED JULY 15, 2016 AND RSP ES-7J DATED APRIL 15, 2016 AND
STANDARD PLAN ES-7J DATED OCTOBER 30, 2015 - PAGE 464 OF THE STANDARD PLANS BOOK DATED 2015.

REVISED STANDARD PLAN RSP ES-7J

2015 REVISED STANDARD PLAN RSP ES-7J

DIST	COUNTY	ROUTE	POST MILES TOTAL PROJECT	SHEET TOTAL SHEETS

Stanley P. Johnson
 REGISTERED CIVIL ENGINEER
 No. CS793
 CIVIL
 No. 3-31-18
 STATE OF CALIFORNIA

April 15, 2016
 PLANS APPROVAL DATE
 THE STATE OF CALIFORNIA OR ITS OFFICERS OR AGENTS SHALL NOT BE RESPONSIBLE FOR THE ACCURACY OR COMPLETENESS OF SCANNED COPIES OF THIS PLAN SHEET.

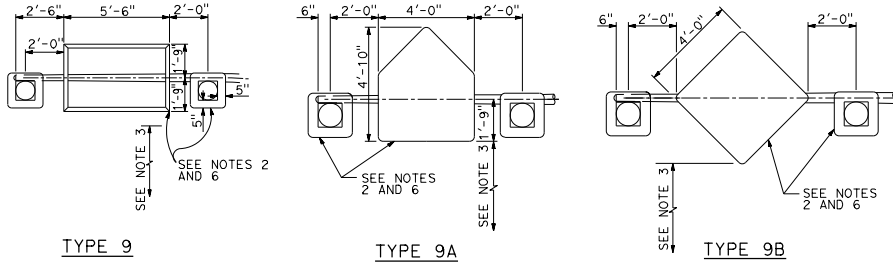

TYPE 9

TYPE 9A

TYPE 9B

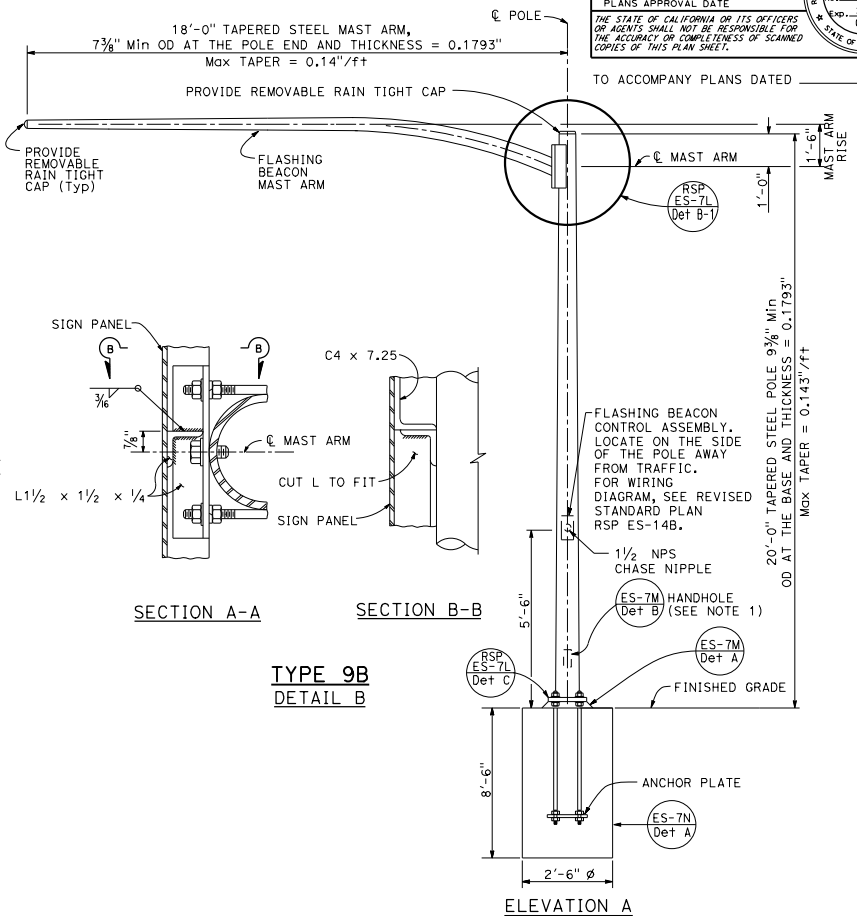

ELEVATION A

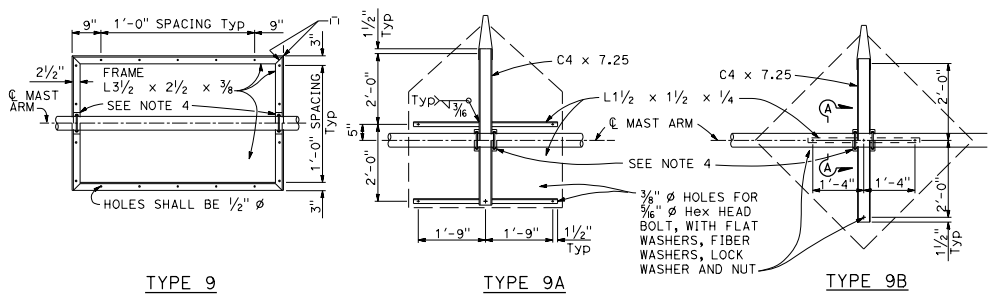

TYPE 9

TYPE 9A

TYPE 9B

FRAME DETAILS
DETAIL A

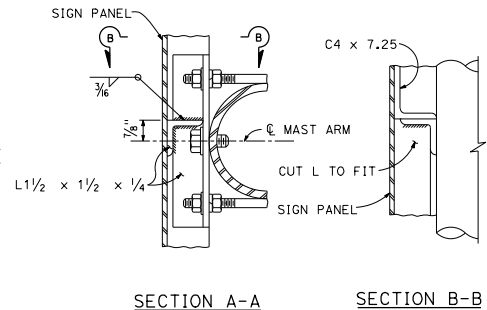

SECTION A-A

SECTION B-B

TYPE 9B
DETAIL B

NOTES:

1. Handhole shall be located on the downstream side of traffic.
2. Install flashing beacons and sign frame. Flashing beacons shall be MAT mounted on pipe tenon (See Standard Plan ES-7M, Detail S).
3. Vertical clearance shall be 17'-0" minimum between roadway and bottom of signal panel.
4. See Revised Standard Plan RSP ES-7L, Detail B, for sign frame mounting details.
5. For additional notes and details, see Revised Standard Plan RSP ES-7L, Detail B-3.
6. 12" flashing beacon with signal indication, standard visor and 5" x 5" backplate (total 2).

STATE OF CALIFORNIA
DEPARTMENT OF TRANSPORTATION
**ELECTRICAL SYSTEMS
(FLASHING BEACON WITH
TYPE 9, 9A AND 9B SIGN)**
NO SCALE

RSP ES-7K DATED APRIL 15, 2016 SUPERSEDES STANDARD PLAN ES-7K
DATED OCTOBER 30, 2015 - PAGE 466 OF THE STANDARD PLANS BOOK DATED 2015.

REVISED STANDARD PLAN RSP ES-7K

2015 REVISED STANDARD PLAN RSP ES-7K

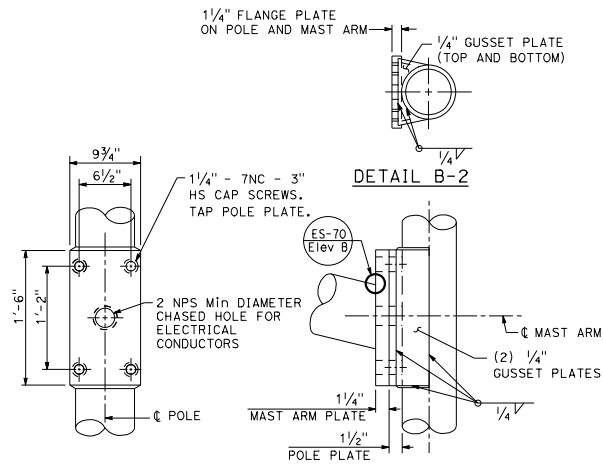

**FLASHING BEACON MAST ARM
CONNECTION DETAILS**

DETAIL B-1

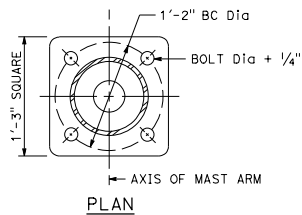

PLAN

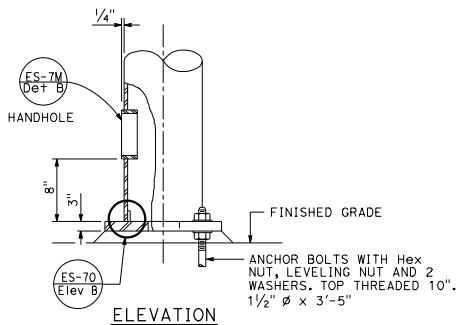

**BASE PLATE AND
ANCHORAGE DETAIL**

DETAIL C

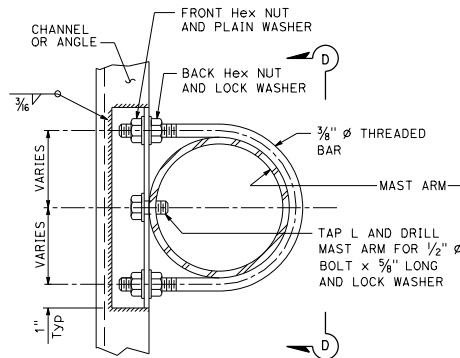

DETAIL B-3

NOTE: Tighten front Hex nuts first,
then tighten back Hex nuts.

SIGN FRAME MOUNTING DETAILS

All types
DETAIL B

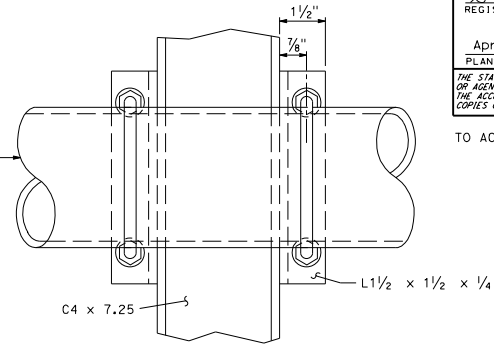

VIEW D-D

DIST	COUNTY	ROUTE	POST MILES TOTAL PROJECT	SHEET TOTAL NO. SHEETS

Stanley P. Johnson
 REGISTERED CIVIL ENGINEER
 No. CS7193
 Exp. 3-31-18
 CIVIL
 STATE OF CALIFORNIA

April 15, 2016
 PLANS APPROVAL DATE
 THE STATE OF CALIFORNIA OR ITS OFFICERS
 OR AGENTS SHALL NOT BE RESPONSIBLE FOR
 THE ACCURACY OR COMPLETENESS OF SCANNED
 COPIES OF THIS PLAN SHEET.

TO ACCOMPANY PLANS DATED _____

STATE OF CALIFORNIA
DEPARTMENT OF TRANSPORTATION
**ELECTRICAL SYSTEMS
(FLASHING BEACON WITH
TYPE 9, 9A AND 9B SIGN)**

NO SCALE

RSP ES-7L DATED APRIL 15, 2016 SUPERSEDES STANDARD PLAN ES-7L
DATED OCTOBER 30, 2015 - PAGE 466 OF THE STANDARD PLANS BOOK DATED 2015.

REVISED STANDARD PLAN RSP ES-7L

2015 REVISED STANDARD PLAN RSP ES-7L

4" x 6 1/2" ROUNDED RECTANGLE HANDHOLE REINFORCED WITH RING WELDED TO OUTSIDE OF POLE. SEE NOTE 4, 1/8" COVER PLATE

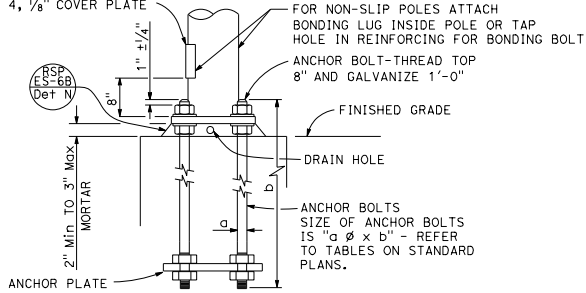

HANDHOLE AND ANCHORAGE

DETAIL A

IDENTIFICATION NUMBER

1. Attach a stamped metal tag with pole's identification number above the handhole. 1/4" high number, minimum.
2. Attach a stamped metal tag with mast arm's identification number to the bottom of the signal mast arm near the pole plate. 1/4" high number, minimum.

Type
 Load case (Use SL for special load case)
 Design wind velocity (mph)
 Signal mast arm length (ft)
 Standard plan year
 Only for poles or mast arms using Detail F
 Only for poles or mast arms using ES-70

SAMPLE IDENTIFICATION NUMBER

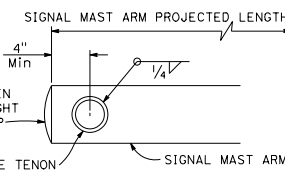

SECTION A-A

NOTES:

1. Provide a Hex nut, leveling nut and 2 washers for each bolt.
2. Luminaire mast arms shall be round, tapered steel tubes, taper of 0.1375" to 0.143-inch per foot with an end section 2 3/8" OD for mounting hardware. Extensions of 2 NPS Standard pipe and 7" long may be used at the option of the manufacturer. When low pressure sodium luminaires are required, the extension shall be 1'-3".
3. Signal mast arms shall be round, tapered steel tubes, maximum taper 0.143-inch per foot.
4. Handhole reinforcement ring shall be 1/4" x 2" for 0.1196" to 0.2391" thick poles, 3/8" x 2" for 0.3125" to 0.375" thick poles.
5. Handholes shall be located on the downstream side of traffic.
6. Detail F, fatigue resistant weld, is required at socket welded signal mast arm plate and pole base plate.
7. Cap screws shall be tightened by the turn-of-nut method 1/3 turn from a snug tight condition. No washer will be required.
8. Outside diameter, wall thickness, and corresponding section properties of poles and mast arms as shown in the Standard Plans are minimums. Unless otherwise specified, alternative sections shall require approval by the Engineer.
9. Design: AASHTO Standard Specifications for Structural Support for Highway Signs, Luminaires, and Traffic Signals, 6th Edition. Basic Wind Speed = 100 mph (3 seconds gust). Yearly Mean Wind Velocity = 15.6 mph.
10. Materials (Structural steel):
 fy = 55,000 psi (tapered steel tube and anchor bolts)
 fy = 50,000 psi (unless otherwise noted)
11. Materials (Reinforced concrete):
 f'c = 3,625 psi
 fy = 60,000 psi

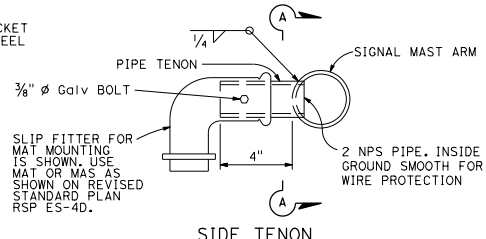
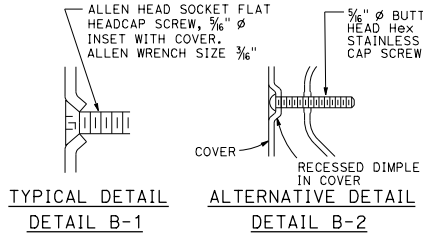

PIPE TENONS
DETAIL S

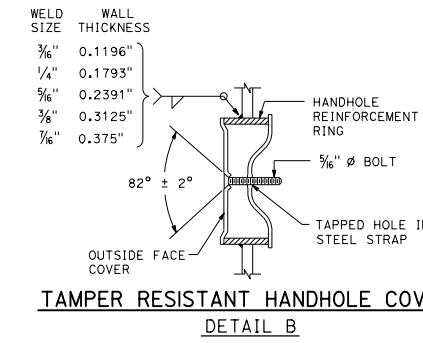
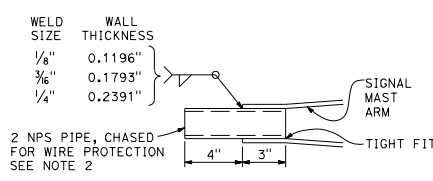

This detail supersedes Detail S when so designated

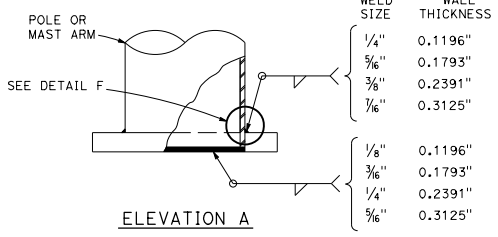
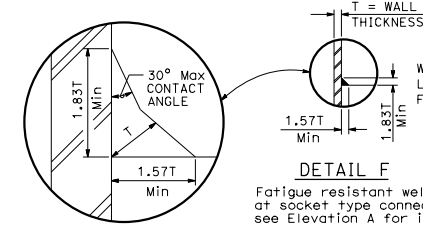

STATE OF CALIFORNIA
DEPARTMENT OF TRANSPORTATION

ELECTRICAL SYSTEMS
(SIGNAL AND LIGHTING STANDARD,
DETAIL No. 1)

NO SCALE

RSP ES-7M DATED APRIL 20, 2018 SUPERSEDES RSP ES-7M DATED JULY 15, 2016 AND STANDARD PLAN ES-7M DATED OCTOBER 30, 2015 - PAGE 467 OF THE STANDARD PLANS BOOK DATED 2015.

REVISED STANDARD PLAN RSP ES-7M

Dist	COUNTY	ROUTE	POST MILES TOTAL PROJECT	SHEET TOTAL No.

REGISTERED CIVIL ENGINEER
 No. CS7193
 Exp. 3-31-20
 CIVIL
 STATE OF CALIFORNIA

April 20, 2018
 PLANS APPROVAL DATE
 THE STATE OF CALIFORNIA OR ITS OFFICERS OR AGENTS SHALL NOT BE RESPONSIBLE FOR THE ACCURACY OR COMPLETENESS OF SCANNED COPIES OF THIS PLAN SHEET.

TO ACCOMPANY PLANS DATED _____

2015 REVISED STANDARD PLAN RSP ES-7M

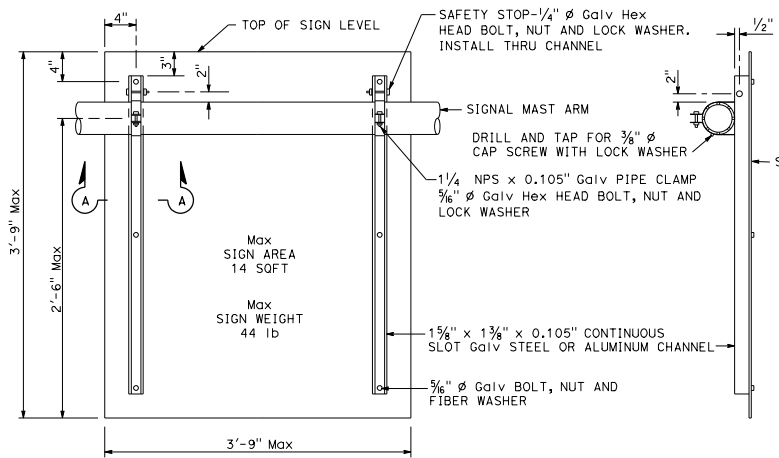

REAR VIEW

SIDE VIEW

SIGN MOUNTING DETAILS
DETAIL U

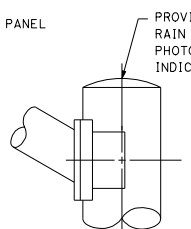

STANDARD TOP
DETAIL B-1

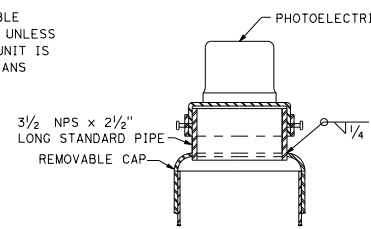

MOUNTING ADAPTER FOR
PHOTOELECTRIC UNIT
DETAIL B-2

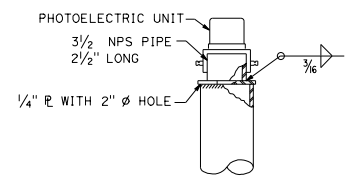

ALTERNATIVE
MOUNTING ADAPTER
DETAIL B-3

POLE TOP DETAILS
DETAIL B

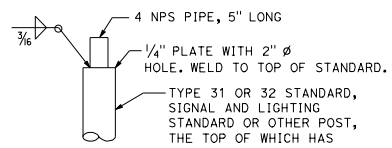

DETAIL C-1

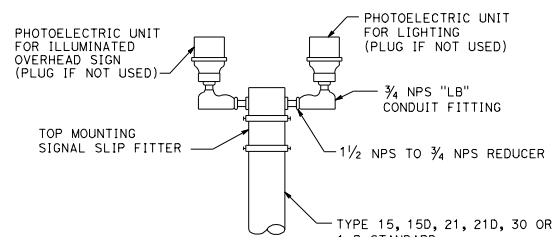

DETAIL C-2

DUAL PHOTOELECTRIC UNIT MOUNTING DETAIL
DETAIL C

STATE OF CALIFORNIA
DEPARTMENT OF TRANSPORTATION

ELECTRICAL SYSTEMS
(SIGNAL AND LIGHTING STANDARD,
DETAIL No. 2)

NO SCALE
RSP ES-7N DATED JULY 15, 2016 SUPERSEDES STANDARD PLAN ES-7N
DATED OCTOBER 30, 2015 - PAGE 468 OF THE STANDARD PLANS BOOK DATED 2015.

REVISED STANDARD PLAN RSP ES-7N

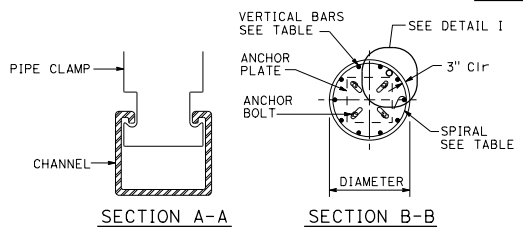

SECTION A-A

SECTION B-B

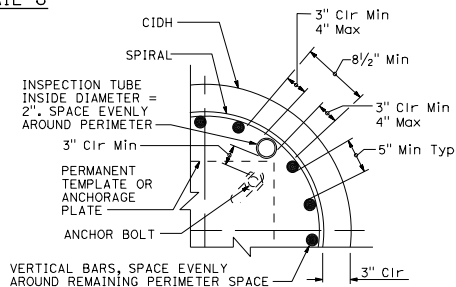

INSPECTION TUBE PLACEMENT
DETAIL I

CIDH REINFORCING AND INSPECTION TUBE SCHEDULE			
CIDH DIAMETER	VERTICAL BARS	SPIRAL	INSPECTION TUBE
2 ft	8-#5		2
2.5 ft	10-#6	#4 AT 6	4*
3 ft	12-#7		
3.5 ft	14-#8	#5 AT 6	4
4 ft	18-#9	2-#4 AT 7	5
4.5 ft	18-#9	2-#5 AT 7	5
5 ft	22-#10	2-#5 AT 7	6
6 ft	26-#11	2-#6 AT 7	7

* FOR SLIP BASE VERSIONS WITH 3 ANCHOR BOLTS USE 3 INSPECTION TUBES.

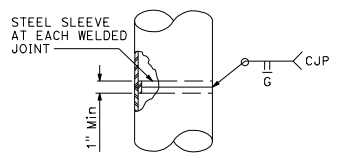

FOR UNIFORM TUBE THICKNESS
DETAIL T-1

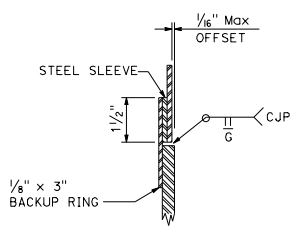

AT TUBE THICKNESS CHANGE
DETAIL T-2

POLE SPLICES
DETAIL T

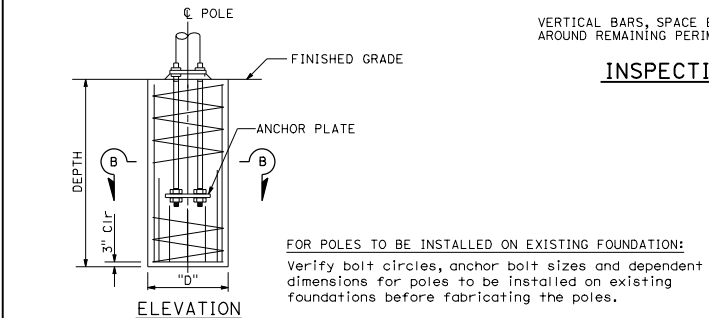

ELEVATION

FOR POLES TO BE INSTALLED ON EXISTING FOUNDATION:
Verify bolt circles, anchor bolt sizes and dependent dimensions for poles to be installed on existing foundations before fabricating the poles.

CAST-IN-DRILLED-HOLE PILE FOUNDATION,
REINFORCED PILE
DETAIL A

2015 REVISED STANDARD PLAN RSP ES-7N

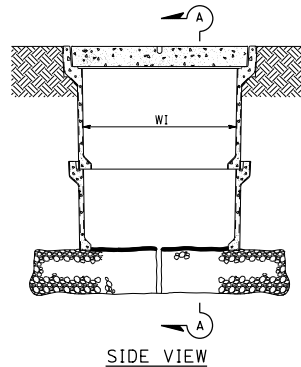
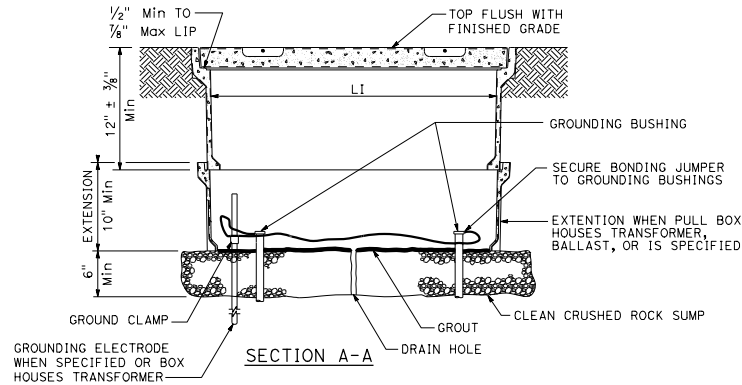

INSTALLATION DETAILS
DETAIL A

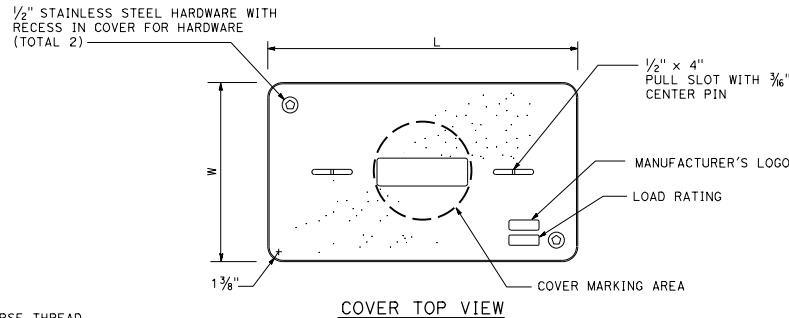

COVER TOP VIEW

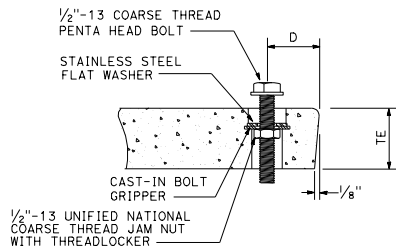

TYPICAL COVER CAPTIVE BOLT
OR SIMILAR

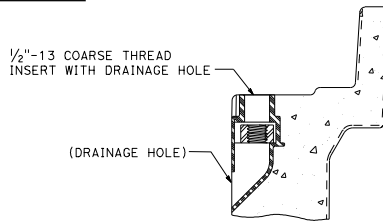

TYPICAL THREADED INSERT
OR SIMILAR

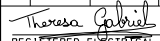
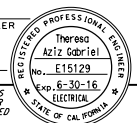
Dist	COUNTY	ROUTE	POST MILES TOTAL PROJECT	SHEET TOTAL SHEETS
 REGISTERED ELECTRICAL ENGINEER				
April 15, 2016 PLANS APPROVAL DATE				
				
THE STATE OF CALIFORNIA OR ITS OFFICERS OR AGENTS SHALL NOT BE RESPONSIBLE FOR THE ACCURACY OR COMPLETENESS OF SCANNED COPIES OF THIS PLAN SHEET.				

TO ACCOMPANY PLANS DATED _____

NOTES:

1. The nominal dimensions of the opening in which the cover sets shall be the same as the cover dimensions except the length and width dimensions shall be 1/8" greater.
2. Covers and boxes shall be interchangeable with California standard male and female gages. When interchanged with a standard male or female gage, the top surfaces shall be flush within 1/8". Top outside radius of covers and pull boxes shall have a 1/8" radius.
3. Dimensions for the cover for non-traffic pull box are nominal values.

PULL BOX	PULL BOX				COVER					
	MINIMUM DEPTH BOX	MINIMUM DEPTH EXTENSION	MINIMUM WEIGHT	LI Min	WI Min	TE	D	L	W	MINIMUM WEIGHT
No. 3/2	12"	N/A	40 lb	1' - 3"	9"	1 3/4"	1 3/4"	1' - 3 1/4" - 1' - 3 3/8"	10" - 10 1/8"	30 lb
No. 5	12"	10"	55 lb	1' - 8"	11"	2"	1 3/4"	1' - 11 1/4"	1' - 1 3/4"	60 lb
No. 6	12"	10"	70 lb	2' - 4 1/4"	1' - 3 1/4"	2"	2"	2' - 6 1/2"	1' - 5 1/2"	85 lb

STATE OF CALIFORNIA
DEPARTMENT OF TRANSPORTATION
ELECTRICAL SYSTEMS
(NON-TRAFFIC PULL BOX)

NO SCALE

RSP ES-8A DATED APRIL 15, 2016 SUPERSEDES STANDARD PLAN ES-8A
DATED OCTOBER 30, 2015 - PAGE 473 OF THE STANDARD PLANS BOOK DATED 2015.

REVISED STANDARD PLAN RSP ES-8A

2015 REVISED STANDARD PLAN RSP ES-8A

Dist*	COUNTY	ROUTE	POST MILES TOTAL PROJECT	SHEET TOTAL NO. SHEETS

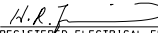
 REGISTERED ELECTRICAL ENGINEER
 July 21, 2017
 PLANS APPROVAL DATE
 No. E15636
 Exp. 12-31-17
THE STATE OF CALIFORNIA OR ITS OFFICERS OR AGENTS SHALL NOT BE RESPONSIBLE FOR THE ACCURACY OR COMPLETENESS OF SCANNED COPIES OF THIS PLAN SHEET.

TO ACCOMPANY PLANS DATED _____

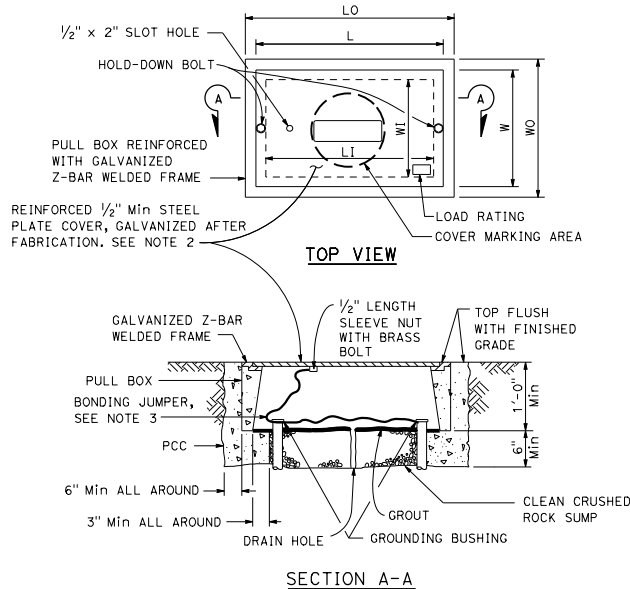

SECTION A-A
No. 3 1/2(T), No. 5(T) AND
No. 6(T) TRAFFIC PULL BOX

NOTES:

- Traffic pull box shall be provided with steel cover and special concrete footing. Steel cover shall have embossed non-skid pattern.
- Steel reinforcing shall be as regularly used in the standard products of the respective manufacturer.
- Bonding jumper for metal covers shall be 3' long, minimum.
- The nominal dimensions of the opening in which the cover sets shall be the same as the cover dimensions except the length and width dimensions shall be 1/8" greater.
- Covers and boxes shall be interchangeable with California standard male and female gages. When interchanged with a standard male or female gage, the top surfaces shall be flush within 1/8".

DIMENSION TABLE

PULL BOX	PULL BOX						COVER	
	MINIMUM * THICKNESS	MINIMUM DEPTH BOX AND EXTENSION	L0	L1	W0	W1	L **	W **
No. 3 1/2(T)	1 1/2"	1'-0"	1'-10" - 1'-11"	1'-5" - 1'-6 1/2"	1'-3" - 1'-4"	10" - 1'-0"	1'-8" - 1'-8 1/2"	1'-1" - 1'-2"
No. 5(T)	1 3/4"	1'-0"	2'-5" - 2'-6"	2'-0" - 2'-1"	1'-6" - 1'-7"	1'-1" - 1'-2"	2'-3" - 2'-3 1/2"	1'-4" - 1'-4 1/2"
No. 6(T)	2"	1'-0"	2'-11" - 3'-1"	2'-6" - 2'-7"	1'-10" - 2'-0"	1'-5" - 1'-6"	2'-9" - 2'-9 1/2"	1'-8" - 1'-8 1/2"

* EXCLUDING CONDUIT WEB ** TOP DIMENSION

STATE OF CALIFORNIA
DEPARTMENT OF TRANSPORTATION
**ELECTRICAL SYSTEMS
(TRAFFIC PULL BOX)**
NO SCALE

RSP ES-8B DATED JULY 21, 2017 SUPERSEDES RSP ES-8B DATED APRIL 15, 2016 AND STANDARD PLAN ES-8B DATED OCTOBER 30, 2015 - PAGE 474 OF THE STANDARD PLANS BOOK DATED 2015.

REVISED STANDARD PLAN RSP ES-8B

2015 REVISED STANDARD PLAN RSP ES-8B

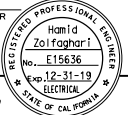
DIST	COUNTY	ROUTE	POST MILES TOTAL PROJECT	SHEET NO.	TOTAL SHEETS
					
REGISTERED ELECTRICAL ENGINEER Hamid Zolfaghar No. E15636 PLANS APPROVAL DATE: April 20, 2018 THE STATE OF CALIFORNIA OR ITS OFFICERS OR AGENTS SHALL NOT BE RESPONSIBLE FOR THE ACCURACY OR COMPLETENESS OF SCANNED COPIES OF THIS PLAN SHEET.					

TO ACCOMPANY PLANS DATED _____

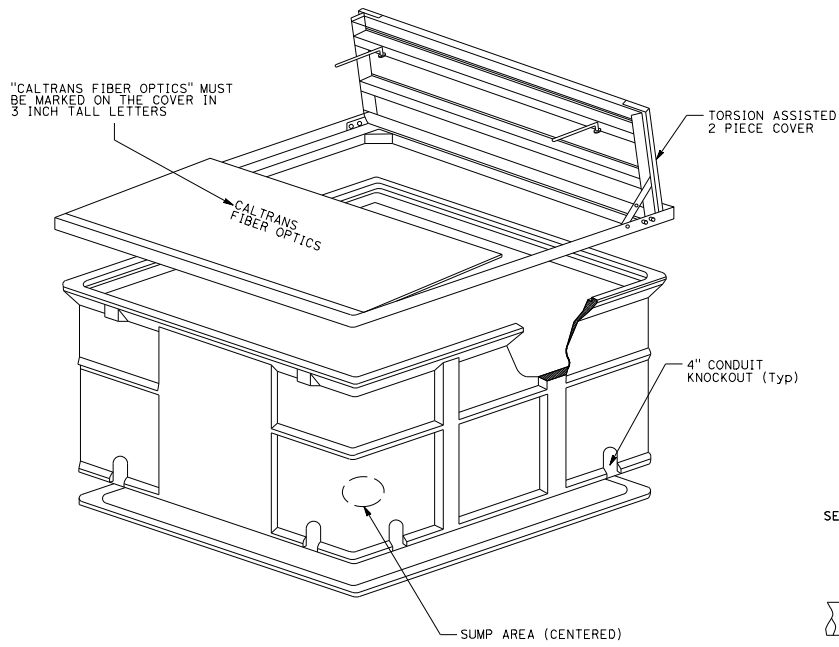

SPLICE VAULT-ISOMETRIC VIEW

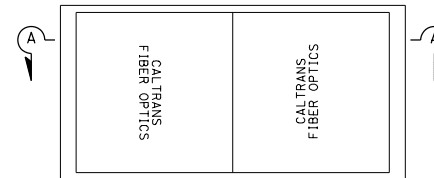

TOP VIEW

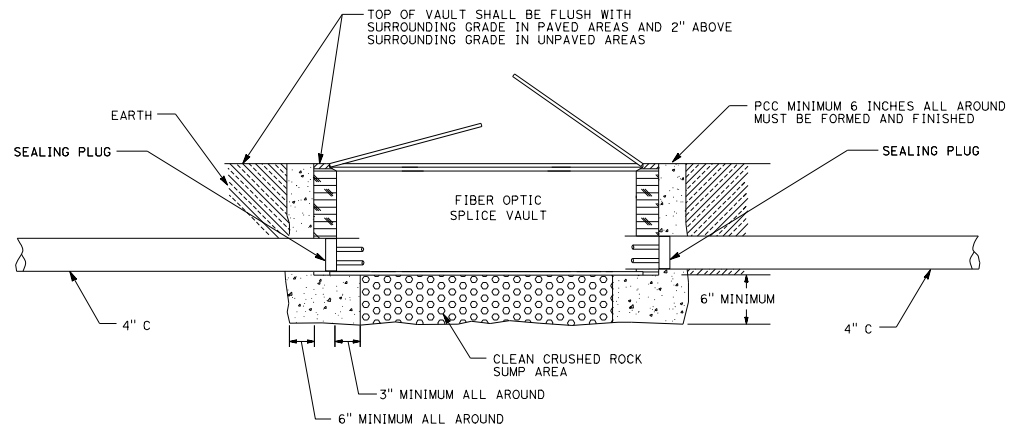

SECTION A-A

STATE OF CALIFORNIA
DEPARTMENT OF TRANSPORTATION
**ELECTRICAL SYSTEMS
(SPLICE VAULTS)**
NO SCALE

RSP ES-8C DATED APRIL 20, 2018 SUPPLEMENTS THE STANDARD PLANS BOOK DATED 2015.

REVISED STANDARD PLAN RSP ES-8C

2015 REVISED STANDARD PLAN RSP ES-8C

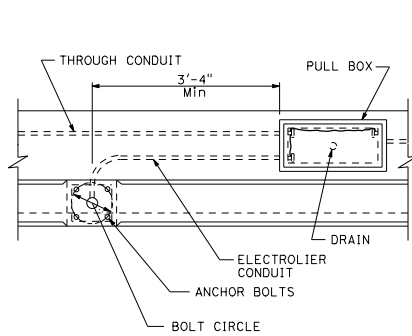

TOP VIEW

No. 3 1/2, 5, OR 6 PULL BOX INSTALLATION

DETAIL A

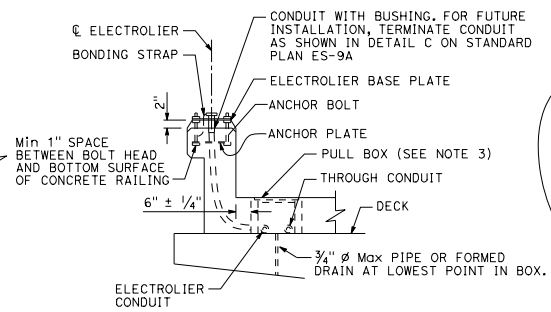

END VIEW

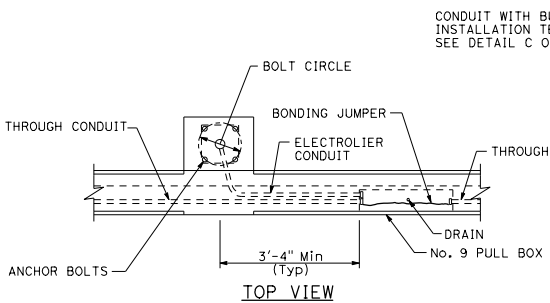

TOP VIEW

No. 9 PULL BOX INSTALLATION

DETAIL B

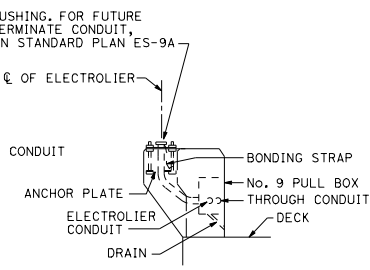

END VIEW

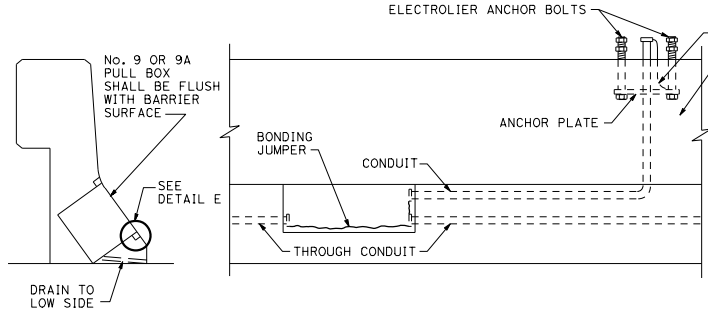

INSTALLATION IN SLOPING PARAPETS

DETAIL D

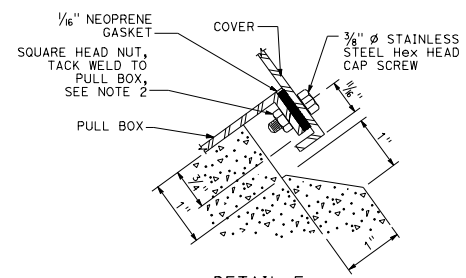

DETAIL E

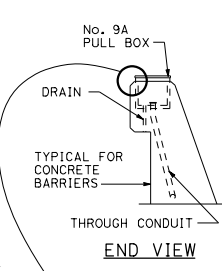

END VIEW

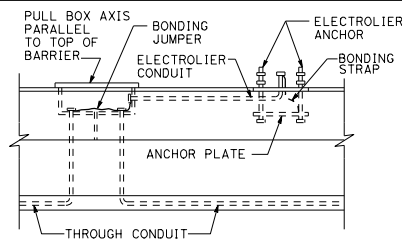

SIDE VIEW

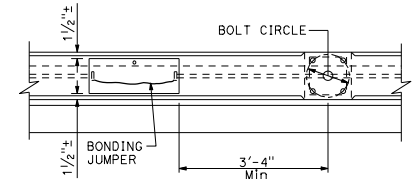
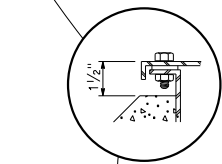

TOP VIEW

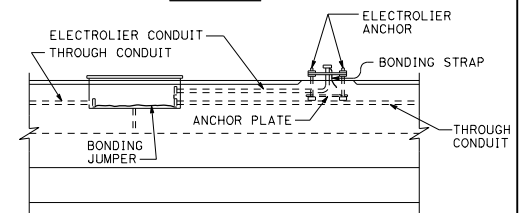

SIDE VIEW

No. 9A PULL BOX INSTALLATION

DETAIL C

NOTES:

1. Axis of pull box shall be parallel to top of barrier, sidewalk or railing.
2. See railing sheet for reinforcement and structural details at electroliers and pull boxes.
3. Top of pull boxes in sidewalk areas shall be flush with sidewalk. Modify base of pull box as required.
4. Boxes inside of vertical barrier or railing shall be closed during pouring of PCC with 1/4" plywood of sufficient size to provide 1:1 chamfer on 3 sides of cover. Upper edge of plywood shall fit against lower edge of raintight hood.
5. Use drain in center if box is horizontal, or at low end if box is inclined. When box is mounted in sloping parapet 1/2" elongated drain hole inside at center or near end as required for drainage.
6. For electrolier anchorage bolts and grouting details, see Revised Standard Plan RSP ES-6B.
7. See Standard Plan B14-3 for conduit in concrete barrier.

STATE OF CALIFORNIA
DEPARTMENT OF TRANSPORTATION
**ELECTRICAL SYSTEMS
(STRUCTURE PULL BOX
INSTALLATIONS)**
NO SCALE

RSP ES-9D DATED JULY 21, 2017 SUPERSEDES RSP ES-9D DATED APRIL 15, 2016 AND STANDARD PLAN ES-9D DATED OCTOBER 30, 2015 - PAGE 478 OF THE STANDARD PLANS BOOK DATED 2015.

REVISED STANDARD PLAN RSP ES-9D

DIST.	COUNTY	ROUTE	POST MILES TOTAL PROJECT	SHEET NO.	TOTAL SHEETS

REGISTERED ELECTRICAL ENGINEER
Hamid Zolfaghar
No. E15636
Exp. 12-31-17
ELECTRICAL
STATE OF CALIFORNIA

PLANS APPROVAL DATE
July 21, 2017

TO ACCOMPANY PLANS DATED _____

2015 REVISED STANDARD PLAN RSP ES-9D

DIST	COUNTY	ROUTE	POST MILES TOTAL PROJECT	SHEET TOTAL SHEETS
<i>Theresa Gabriel</i> REGISTERED ELECTRICAL ENGINEER				
April 15, 2016 PLANS APPROVAL DATE				
Theresa Aziz Gabriel No. E15129 Exp. 6-30-16 REGISTERED PROFESSIONAL ENGINEER ELECTRICAL STATE OF CALIFORNIA				
THE STATE OF CALIFORNIA OR ITS OFFICERS OR AGENTS SHALL NOT BE RESPONSIBLE FOR THE ACCURACY OR COMPLETENESS OF SCANNED COPIES OF THIS PLAN SHEET.				

TO ACCOMPANY PLANS DATED _____

2015 REVISED STANDARD PLAN RSP ES-9E

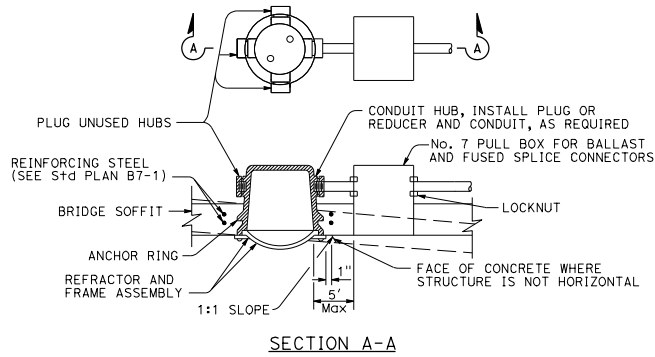

FLUSH-MOUNTED SOFFIT LUMINAIRE INSTALLATION
DETAIL F

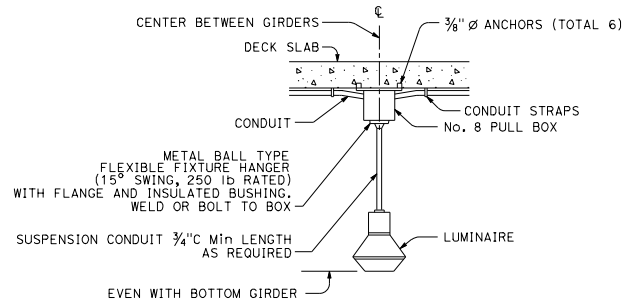

PENDANT SOFFIT LUMINAIRE INSTALLATION
DETAIL P

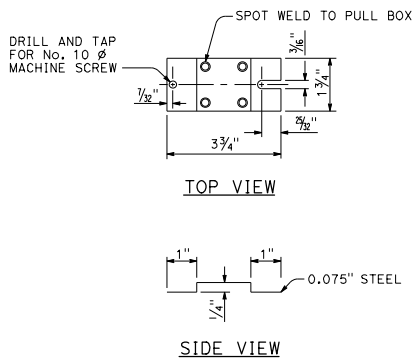

TERMINAL BLOCK MOUNTING BRACKET
DETAIL T

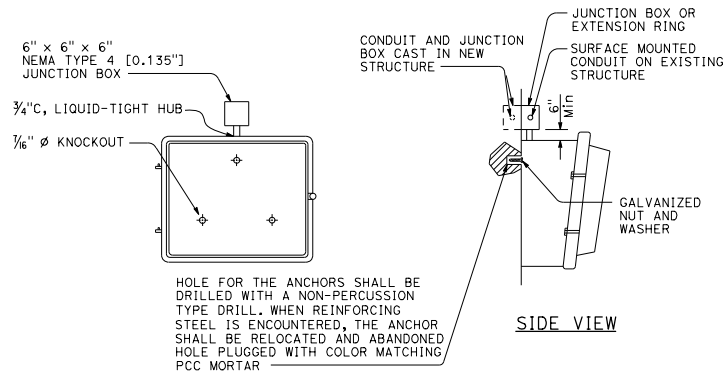

WALL-MOUNTED LUMINAIRE INSTALLATION
DETAIL W

STATE OF CALIFORNIA
DEPARTMENT OF TRANSPORTATION
ELECTRICAL SYSTEMS
(FLUSH-MOUNTED SOFFIT,
PENDANT SOFFIT
AND WALL-MOUNTED LUMINAIRE
STRUCTURE INSTALLATIONS)

NO SCALE

RSP ES-9E DATED APRIL 15, 2016 SUPERSEDES STANDARD PLAN ES-9E DATED
DATED OCTOBER 30, 2015 - PAGE 479 OF THE STANDARD PLANS BOOK DATED 2015.

REVISED STANDARD PLAN RSP ES-9E

NOTE:

Curves represent the minimum maintained illuminance (FC).

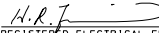
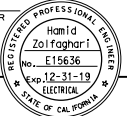
DIST	COUNTY	ROUTE	POST MILES TOTAL PROJECT	SHEET TOTAL SHEETS
 REGISTERED ELECTRICAL ENGINEER				
April 20, 2018 PLANS APPROVAL DATE				
				
THE STATE OF CALIFORNIA OR ITS OFFICERS OR AGENTS SHALL NOT BE RESPONSIBLE FOR THE ACCURACY OR COMPLETENESS OF SCANNED COPIES OF THIS PLAN SHEET.				

TO ACCOMPANY PLANS DATED _____

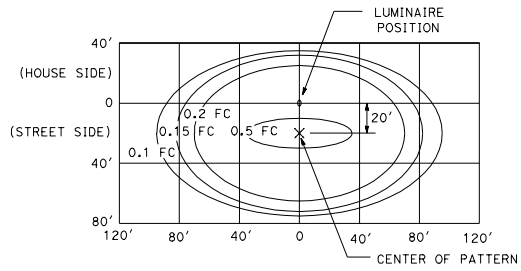

ROADWAY 1
34' Mounting Height
165 W (Max)

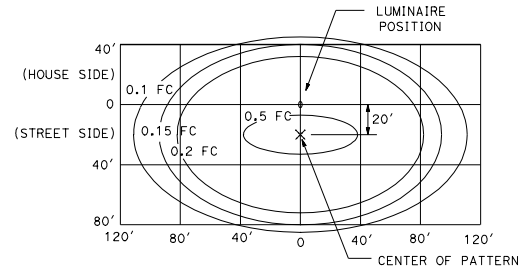

ROADWAY 2
40' Mounting Height
235 W (Max)

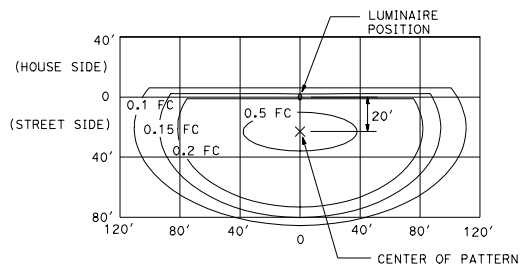

ROADWAY 3
40' Mounting Height
with back side control
235 W (Max)



ROADWAY 4
40' Mounting Height
300 W (Max)

STATE OF CALIFORNIA
DEPARTMENT OF TRANSPORTATION
**ELECTRICAL SYSTEMS
(ISOFOOTCANDLE CURVES)**

NO SCALE

RSP ES-10A DATED APRIL 20, 2018 SUPERSEDES RSP ES-10A DATED JULY 21, 2017 AND
STANDARD PLAN ES-10A DATED OCTOBER 30, 2015 - PAGE 481 OF THE STANDARD PLANS BOOK DATED 2015.

REVISED STANDARD PLAN RSP ES-10A

2015 REVISED STANDARD PLAN RSP ES-10A

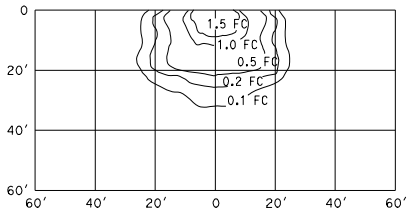

WALL-MOUNTED
15' Mounting Height
ANSI Designation S62
Lamp operated at 5,800 lm
70 W (Max)

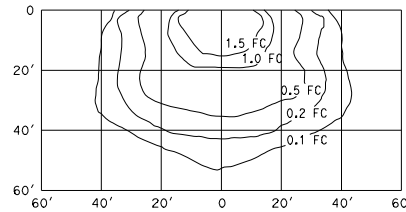

WALL-MOUNTED
15' Mounting Height
ANSI Designation S54
Lamp operated at 9,500 lm
100 W (Max)

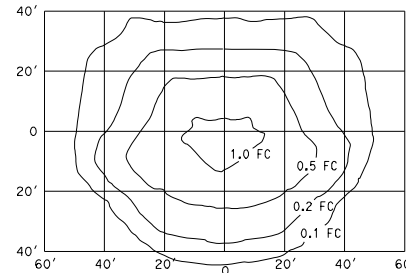

FLUSH-MOUNTED SOFFIT
17' Mounting Height
ANSI Designation S62
Lamp operated at 5,800 lm
70 W (Max)

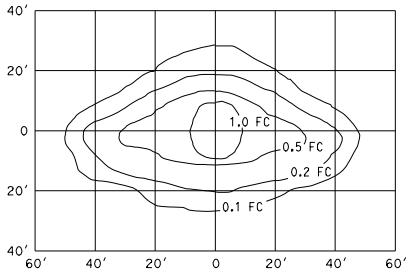

PENDANT SOFFIT
TYPE III SHORT
17' Mounting Height
ANSI Designation S62
Lamp operated at 5,800 lm
70 W (Max)

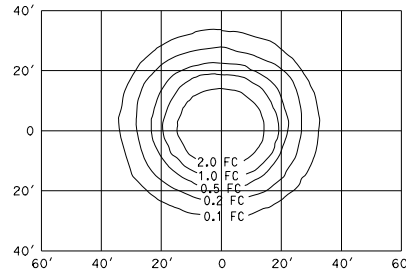

PENDANT SOFFIT
17' Mounting Height
ANSI Designation S62
Lamp operated at 5,800 lm
70 W (Max)

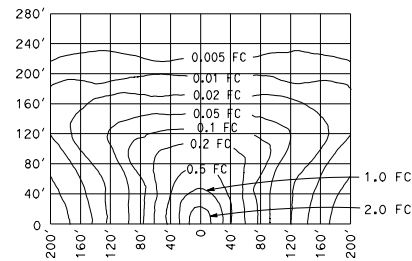

LOW-PRESSURE SODIUM
40' Mounting Height
Lamp operated at 33,000 lm
180 W (Max)

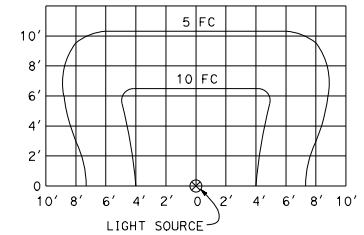

SIGN ILLUMINATION
85 W (Max)

DIST	COUNTY	ROUTE	POST MILES TOTAL PROJECT	SHEET TOTAL SHEETS

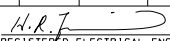
 REGISTERED ELECTRICAL ENGINEER
 Hamid Zolfaghar
 No. E15636
 Exp. 12-31-19
 ELECTRICAL
 STATE OF CALIFORNIA

PLANS APPROVAL DATE
 April 20, 2018

THE STATE OF CALIFORNIA OR ITS OFFICERS OR AGENTS SHALL NOT BE RESPONSIBLE FOR THE ACCURACY OR COMPLETENESS OF SCANNED COPIES OF THIS PLAN SHEET.

TO ACCOMPANY PLANS DATED _____

NOTE:
Curves represent the minimum maintained illuminance (FC).

STATE OF CALIFORNIA
DEPARTMENT OF TRANSPORTATION
ELECTRICAL SYSTEMS
(ISOFOOTCANDLE CURVES)

NO SCALE

RSP ES-10B DATED APRIL 20, 2018 SUPERSEDES RSP ES-10B DATED JULY 21, 2017 AND STANDARD PLAN ES-10B DATED OCTOBER 30, 2015 - PAGE 482 OF THE STANDARD PLANS BOOK DATED 2015.

REVISED STANDARD PLAN RSP ES-10B

2015 REVISED STANDARD PLAN RSP ES-10B

DIST	COUNTY	ROUTE	POST MILES TOTAL PROJECT	SHEET TOTAL SHEETS

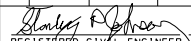
 REGISTERED CIVIL ENGINEER

July 15, 2016
 PLANS APPROVAL DATE

Stanley P. Johnson
 No. CS793
 Exp. 3-31-18
 CIVIL
 STATE OF CALIFORNIA

THE STATE OF CALIFORNIA OR ITS OFFICERS OR AGENTS SHALL NOT BE RESPONSIBLE FOR THE ACCURACY OR COMPLETENESS OF SCANNED COPIES OF THIS PLAN SHEET.

TO ACCOMPANY PLANS DATED _____

STANDARD TYPE	SETBACK (DIMENSION A)
32	30'-0" (Min)
31	20'-0" (Min)
15, 15D, 15-SB, 21, 21D, 30	ARM LENGTH (Min)

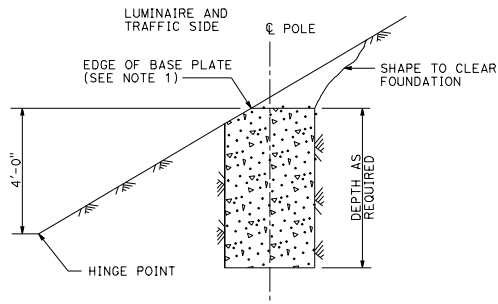

CUT SLOPES
STEEPER THAN 4:1,
LESS THAN 2:1
DETAIL A-1
 See Note 2 and 3

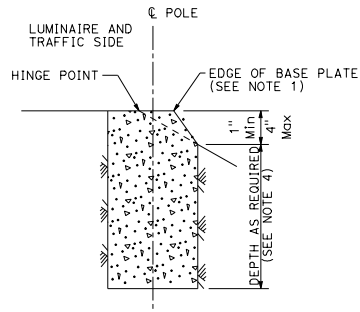

FILL SLOPES
STEEPER THAN 4:1,
LESS THAN 2:1
DETAIL A-2
 See Note 2 and 3

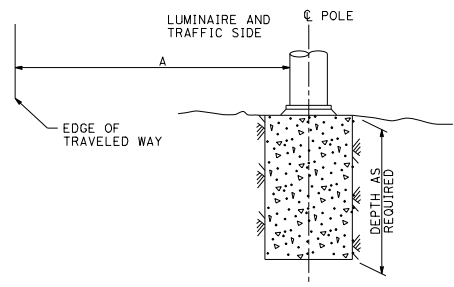

FLAT SECTIONS, CUT OR FILL SLOPES
4:1 OR FLATTER
DETAIL A-3
 See Note 2

FOUNDATIONS ADJACENT TO ALL ROADWAYS EXCEPT
IN SIDEWALK, MEDIAN AND ISLAND AREAS
DETAIL A

NOTES:

1. Where a portion of the foundation is above grade, the top edges shall have a 1" chamfer.
2. Slopes shall be horizontal to vertical ratio (Horizontal : Vertical).
3. Horizontal setbacks on cut and fill slopes steeper than 4:1 shall not exceed the distance shown for flat sections.
4. CIDH embedment depth shall be increased beyond standard depths by the diameter of the CIDH.

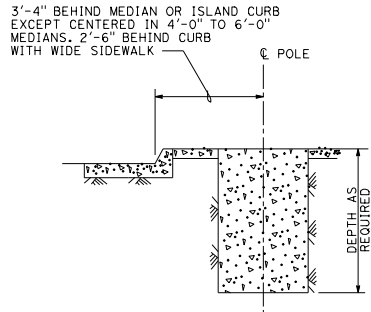

MEDIAN, ISLAND
OR WIDE SIDEWALK
DETAIL B-1
 7' Wide and wider

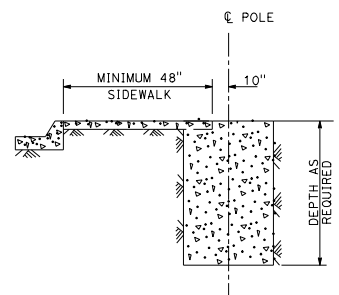

NARROW SIDEWALK
DETAIL B-2
 Less than 7' wide

FOUNDATIONS IN SIDEWALK, MEDIAN AND ISLAND AREAS
DETAIL B

STATE OF CALIFORNIA
 DEPARTMENT OF TRANSPORTATION
ELECTRICAL SYSTEMS
(FOUNDATION INSTALLATIONS)

NO SCALE

RSP ES-11 DATED JULY 15, 2016 SUPERSEDES STANDARD PLAN ES-11 DATED DATED OCTOBER 30, 2015 - PAGE 483 OF THE STANDARD PLANS BOOK DATED 2015.

REVISED STANDARD PLAN RSP ES-11

2015 REVISED STANDARD PLAN RSP ES-11

DIST	COUNTY	ROUTE	POST MILES TOTAL PROJECT	SHEET TOTAL NO. SHEETS

H. R. F.
 REGISTERED ELECTRICAL ENGINEER
 Hamid Zolfaghari
 No. E15636
 Exp. 12-31-17
 ELECTRICAL
 STATE OF CALIFORNIA

July 21, 2017
 PLANS APPROVAL DATE
 THE STATE OF CALIFORNIA OR ITS OFFICERS
 OR AGENTS SHALL NOT BE RESPONSIBLE FOR
 THE ACCURACY OR COMPLETENESS OF SCANNED
 COPIES OF THIS PLAN SHEET.

TO ACCOMPANY PLANS DATED _____

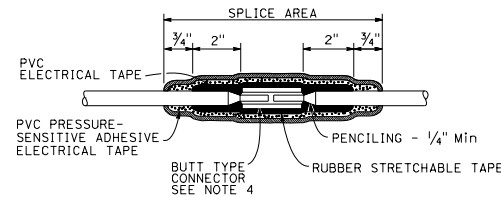
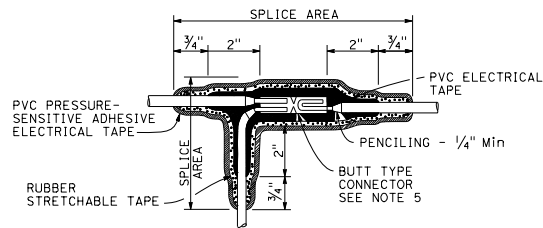
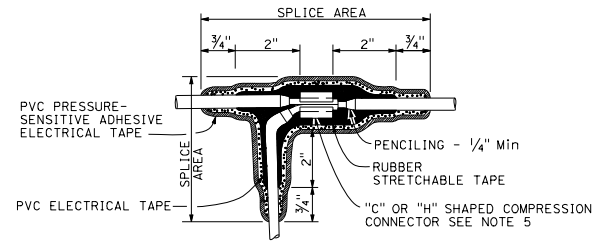
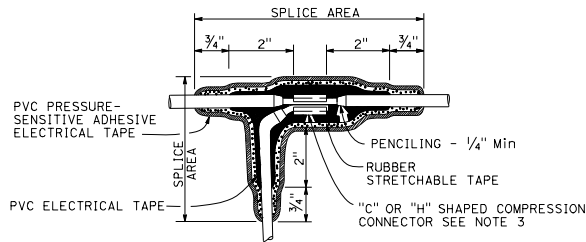

NOTES:

1. Dimensions are minimum.
2. Rubber tapes shall be rolled after application.
3. Between 1 free-end and 1 through conductor.
4. Between 2 free-end conductors.
5. Between 3 free-end conductors.

TYPICAL SPLICE INSULATION METHOD B

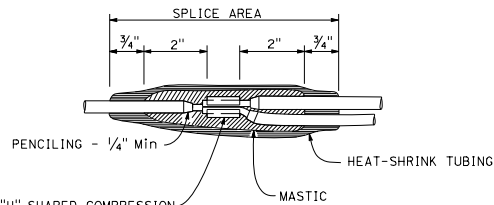

"C" OR "H" SHAPED COMPRESSION
CONNECTOR SEE NOTE 5

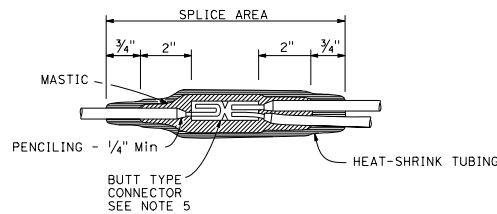

TYPICAL SPLICE INSULATION HEAT-SHRINK TUBING

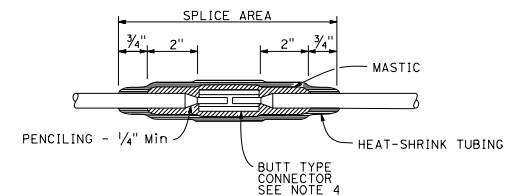

STATE OF CALIFORNIA
DEPARTMENT OF TRANSPORTATION
**ELECTRICAL SYSTEMS
(SPLICE INSULATION METHODS DETAILS)**

NO SCALE

RSP ES-13A DATED JULY 21, 2017 SUPERSEDES RSP ES-13A DATED APRIL 15, 2016 AND STANDARD
PLAN ES-13A DATED OCTOBER 30, 2015 - PAGE 484 OF THE STANDARD PLANS BOOK DATED 2015.

REVISED STANDARD PLAN RSP ES-13A

2015 REVISED STANDARD PLAN RSP ES-13A

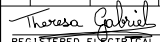
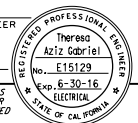
DIST	COUNTY	ROUTE	POST MILES TOTAL PROJECT	SHEET TOTAL NO. SHEETS
 REGISTERED ELECTRICAL ENGINEER				
April 15, 2016 PLANS APPROVAL DATE				
				
THE STATE OF CALIFORNIA OR ITS OFFICERS OR AGENTS SHALL NOT BE RESPONSIBLE FOR THE ACCURACY OR COMPLETENESS OF SCANNED COPIES OF THIS PLAN SHEET.				

TO ACCOMPANY PLANS DATED _____

CIRCUIT VOLTAGE	FUSE VOLTAGE RATING	FUSE CURRENT RATING						
		HPS LAMP BALLAST		LOW PRESSURE SODIUM BALLAST	INDUCTION SIGN LIGHTING	SINGLE PHASE (TWO WIRE) TRANSFORMERS (PRIMARY SIDE)		
		70 W	100 W	180 W	85 W	1 kVA	2 kVA	3 kVA
120 V	250 V	5 A	5 A	5 A	5 A	10 A	20 A	30 A
240 V	250 V	5 A	5 A	5 A	5 A	6 A	10 A	20 A
480 V	500-600 V	5 A	5 A	3 A	1 A (SEE NOTE 2)	3 A	6 A	10 A

NOTES:

- Primary lines of multiple ballasts shall be provided with fused connectors. Fuse ratings shall be as noted above.
- See Standard Plan ES-15D, Type SC3 control.

FUSE RATINGS FOR FUSED CONNECTORS

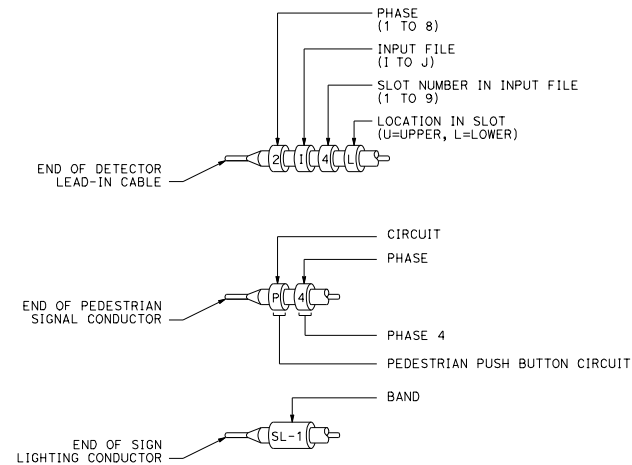
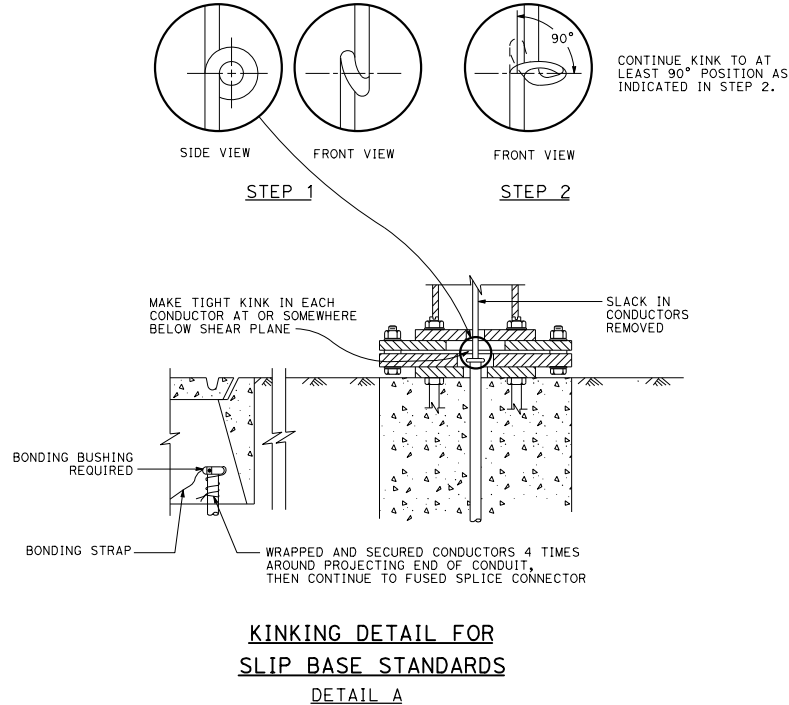

STATE OF CALIFORNIA
DEPARTMENT OF TRANSPORTATION
**ELECTRICAL SYSTEMS
(FUSE RATING, KINKING AND BANDING DETAIL)**

NO SCALE

RSP ES-13B DATED APRIL 15, 2016 SUPERSEDES STANDARD PLAN ES-13B
DATED OCTOBER 30, 2015 - PAGE 485 OF THE STANDARD PLANS BOOK DATED 2015.

REVISED STANDARD PLAN RSP ES-13B

2015 REVISED STANDARD PLAN RSP ES-13B

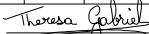
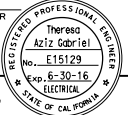
DIST	COUNTY	ROUTE	POST MILES TOTAL PROJECT	SHEET TOTAL SHEETS
 REGISTERED ELECTRICAL ENGINEER				
April 15, 2016 PLANS APPROVAL DATE				
				
THE STATE OF CALIFORNIA OR ITS OFFICERS OR AGENTS SHALL NOT BE RESPONSIBLE FOR THE ACCURACY OR COMPLETENESS OF SCANNED COPIES OF THIS PLAN SHEET.				

TO ACCOMPANY PLANS DATED _____

THE FLASHER SHALL MATE WITH A CINCH-JONES SOCKET S-406-SB OR EQUAL AND CONNECTED AS FOLLOWS:

PIN	CIRCUIT	PIN	CIRCUIT
7	LOAD	10	NEUTRAL
8	LOAD	11	LINE
9	CHASSIS GROUND	12	NOT USED



**CONNECTOR SOCKET
SOLID STATE FLASHER UNIT**

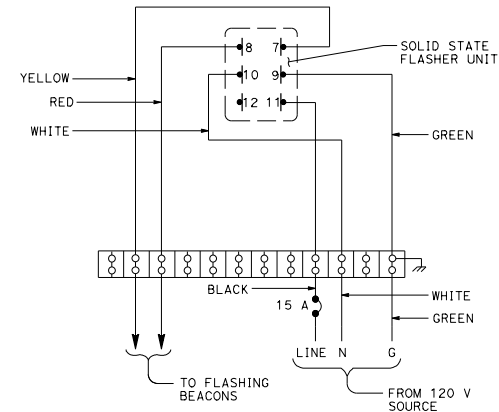

**WIRING DIAGRAM
FLASHING BEACON CONTROL ASSEMBLY**

DETAIL B

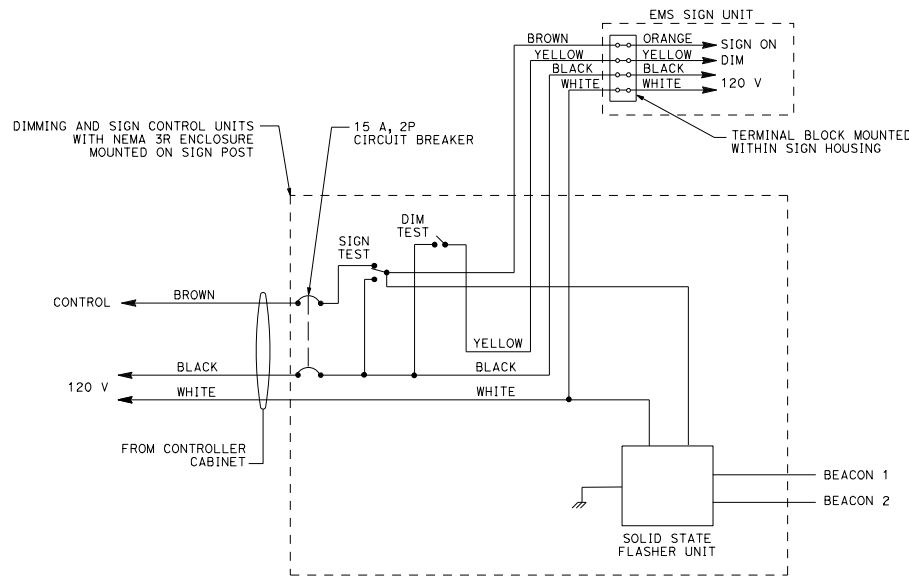

**WIRING DIAGRAM
LED EXTINGUISHABLE MESSAGE SIGN**

DETAIL A

STATE OF CALIFORNIA
DEPARTMENT OF TRANSPORTATION

**ELECTRICAL SYSTEMS
(CONTROL ASSEMBLY
WIRING DIAGRAMS)**

NO SCALE

RSP ES-14B DATED APRIL 15, 2016 SUPERSEDES STANDARD PLAN ES-14B
DATED OCTOBER 30, 2015 - PAGE 487 OF THE STANDARD PLANS BOOK DATED 2015.

REVISED STANDARD PLAN RSP ES-14B

2015 REVISED STANDARD PLAN RSP ES-14B

POLE EXTENSION TYPE	POLE DATA				HANDHOLE SIZE
	HEIGHT "h"	Min OD		THICKNESS	
		BASE	TOP		
CCTV 5	5'	4 $\frac{3}{8}$ "	3 $\frac{3}{4}$ "	0.1793"	3" x 5"
CCTV 10	10'	5 $\frac{1}{4}$ "			
CCTV 15	15'	5 $\frac{5}{8}$ "			

CCTV MOUNTING ADAPTER DETAIL SHALL BE SUBMITTED BY THE CONTRACTOR FOR THE ENGINEER'S APPROVAL, SEE DETAIL D

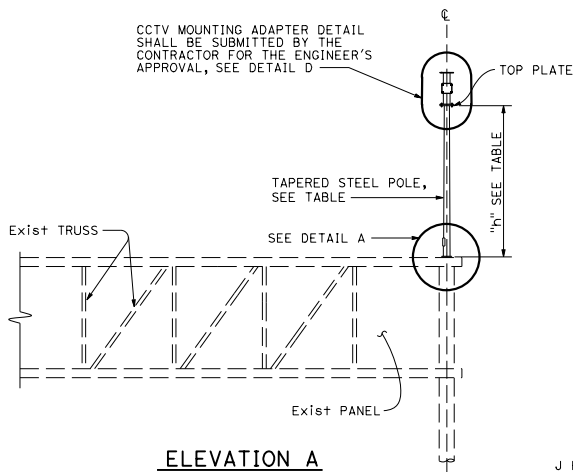

ELEVATION A

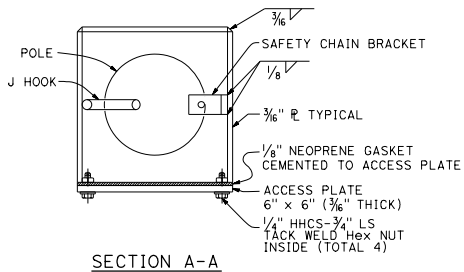

SECTION A-A

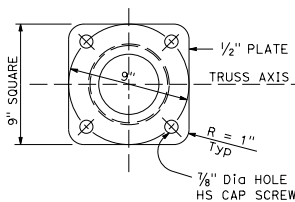

SECTION K-K

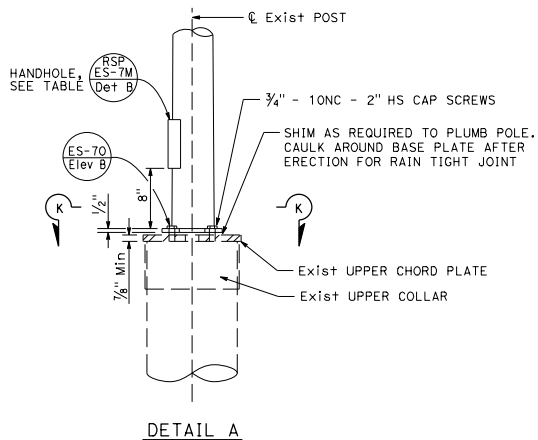

DETAIL A

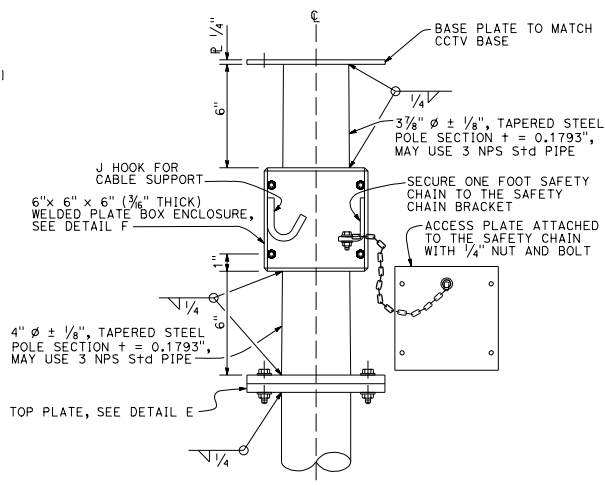

**CLOSED CIRCUIT TELEVISION MOUNTING ADAPTER
DETAIL D**

NOTES:

1. Verify controlling field dimensions before ordering or fabricating any material.
2. Bolt hole locations may vary at the discretion of the Engineer.
3. See Std Plan S13.
4. For wind loading see Revised Standard Plan RSP ES-7M.
5. Materials (Structural Steel):
 - a. fy = 55,000 psi (tapered steel tube)
 - b. fy = 50,000 psi (unless otherwise noted)

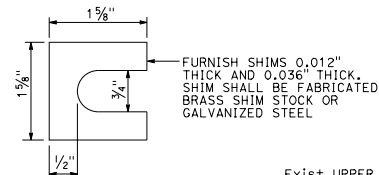

**SHIM
DETAIL B**

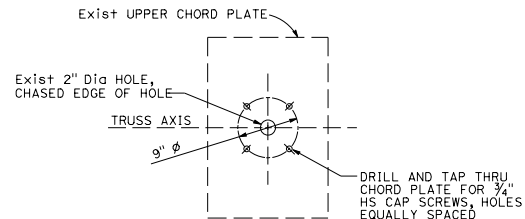

**UPPER CHORD PLATE
DETAIL C**
See Note 3

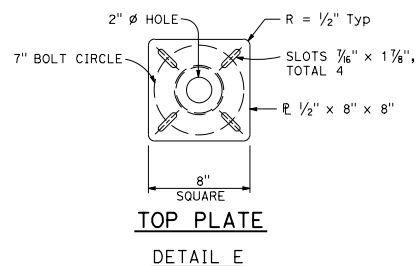

**TOP PLATE
DETAIL E**

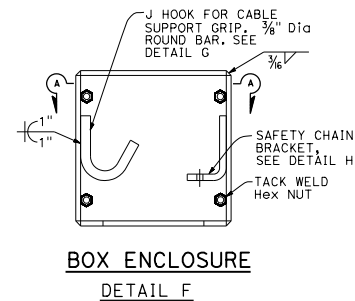

**BOX ENCLOSURE
DETAIL F**

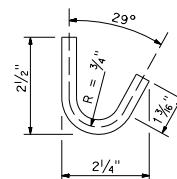

**J HOOK
DETAIL G**

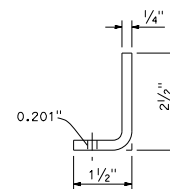

**SAFETY CHAIN BRACKET
DETAIL H**

STATE OF CALIFORNIA
DEPARTMENT OF TRANSPORTATION

**ELECTRICAL SYSTEMS
(CLOSED CIRCUIT TELEVISION,
5' TO 15' OVERHEAD SIGN MOUNTED POLE)
NO SCALE**

RSP ES-16A DATED APRIL 20, 2018 SUPERSEDES RSP ES-16A DATED JULY 15, 2016 AND
STANDARD PLAN ES-16A DATED OCTOBER 30, 2015 - PAGE 493 OF THE STANDARD PLANS BOOK DATED 2015.

REVISED STANDARD PLAN RSP ES-16A

2015 REVISED STANDARD PLAN RSP ES-16A

POLE TYPE	HEIGHT "h"	POLE DATA		THICKNESS	BASE PLATE DATA			CIDH	
		Min OD	THICKNESS		"c"	THICKNESS	ANCHOR BOLT SIZE	BC = BOLT CIRCLE	Diø
CCTV 25	25'	7 3/8"	3 3/4"	0.1793"	1'-1"	1"	1 1/2" ø x 36"	11 1/2"	7'-0"
CCTV 30	30'	8"			1'-1 1/2"			1'-0"	7'-6"
CCTV 35	35'	8 5/8"			1'-2"			1'-1"	8'-0"
CCTV 40	40'	9 3/8"			1'-1 1/2"			1'-1 1/2"	8'-6"
CCTV 45	45'	10"			1'-2"		1'-2"	8'-6"	

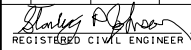

Dist#	COUNTY	ROUTE	POST MILES	SHEET TOTAL
			TOTAL PROJECT	NO. SHEETS

 REGISTERED CIVIL ENGINEER
 No. CS7793
 Exp. 3-31-20
 CIVIL
 STATE OF CALIFORNIA

April 20, 2018
 PLANS APPROVAL DATE
 THE STATE OF CALIFORNIA OR ITS OFFICERS OR AGENTS SHALL NOT BE RESPONSIBLE FOR THE ACCURACY OR COMPLETENESS OF SCANNED COPIES OF THIS PLAN SHEET.

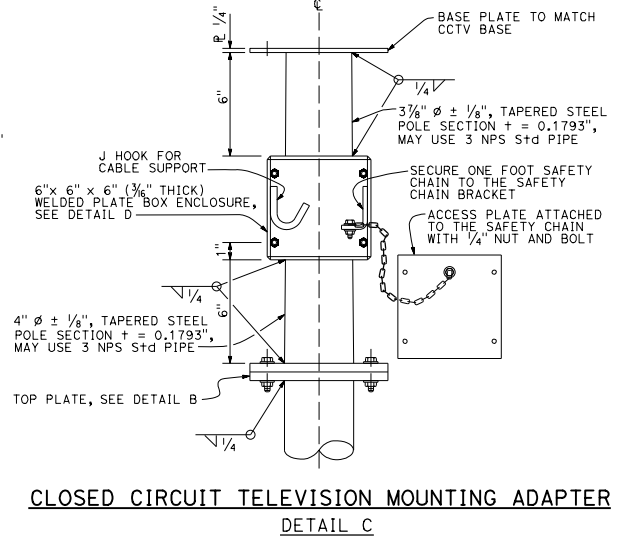
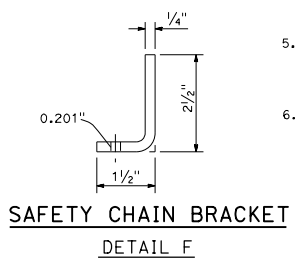
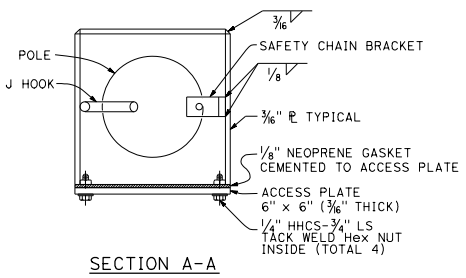
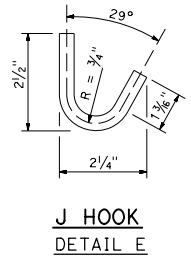
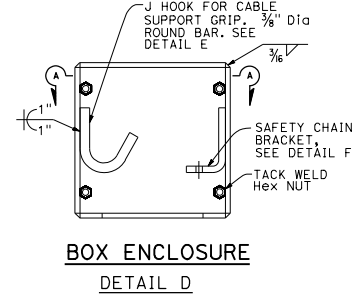
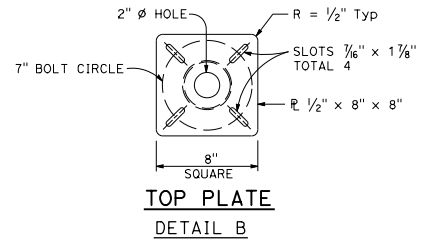
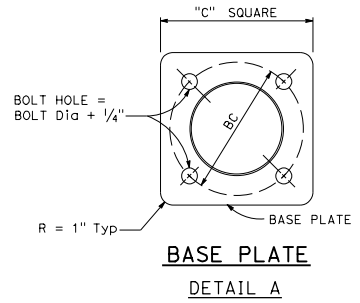
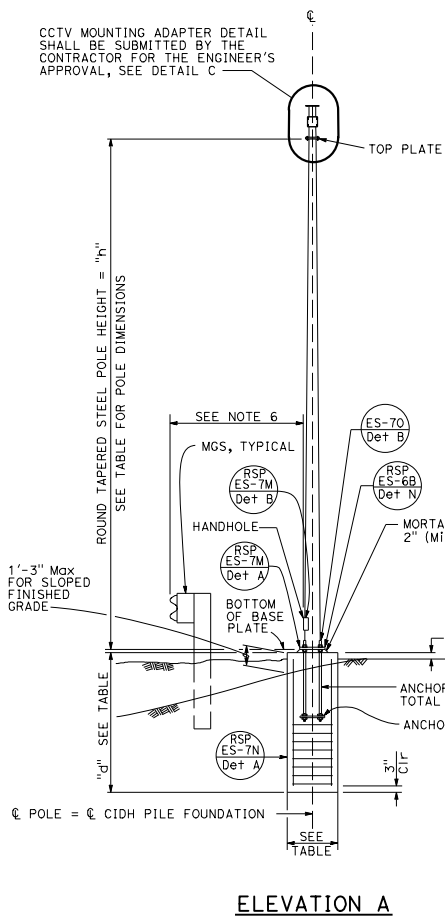
TO ACCOMPANY PLANS DATED _____



- NOTES:**
1. Verify controlling field dimensions before ordering or fabricating any material.
 2. During pole installation, the post shall be raked as necessary with the use of leveling nuts to provide a plumb pole axis.
 3. For wind loading see Revised Standard Plan RSP ES-7M.
 4. Materials (Structural Steel):
 - a. fy = 55,000 psi (tapered steel tube and anchor bolts)
 - b. fy = 50,000 psi (unless otherwise noted)
 5. Materials (Reinforced Concrete):
 - a. f'c = 3,625 psi
 - b. fy = 60,000 psi
 6. See  thru 

STATE OF CALIFORNIA
 DEPARTMENT OF TRANSPORTATION
**ELECTRICAL SYSTEMS
 (CLOSED CIRCUIT TELEVISION,
 25' TO 45' POLE)**
 NO SCALE

RSP ES-16B DATED APRIL 20, 2018 SUPERSEDES RSP ES-16B DATED JULY 15, 2016 AND STANDARD PLAN ES-16B DATED OCTOBER 30, 2015 - PAGE 494 OF THE STANDARD PLANS BOOK DATED 2015.

REVISED STANDARD PLAN RSP ES-16B

2015 REVISED STANDARD PLAN RSP ES-16B

POLE TYPE	POLE DATA					BASE PLATE DATA				CIDH PILE DATA		
	HEIGHT "h"	Min OD		THICKNESS BOTTOM SEGMENT (Min 25' LONG)	Min THICKNESS UPPER SEGMENT(S)	Dia	THICKNESS	ANCHOR BOLT SIZE		BC = BOLT CIRCLE	"D"	"L"
		BASE	TOP					TOTAL	"d"			
HM CCTV 50	50'	18"	10 ⁷ / ₈ "	0.3125"	0.1875"	25"	2"	12	2 ¹ / ₄ "	20"	3'-6"	13'-0"
HM CCTV 60	60'		9 ¹ / ₂ "			30"					4'-0"	
HM CCTV 70	70'	22"	12"	0.375"	0.25"	33"	3"	3"	27"	4'-6"	14'-0"	
HM CCTV 80	80'	22"	11 ⁵ / ₈ "			42"					37"	6'-0"
HM CCTV 90	90'	25"	17 ¹ / ₈ "									

Dist#	COUNTY	ROUTE	POST MILES TOTAL PROJECT	SHEET TOTAL No. SHEETS

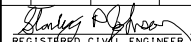
 REGISTERED CIVIL ENGINEER
 No. CS7793
 Exp. 3-31-20
 CIVIL
 STATE OF CALIFORNIA

April 20, 2018
 PLANS APPROVAL DATE
 THE STATE OF CALIFORNIA OR ITS OFFICERS OR AGENTS SHALL NOT BE RESPONSIBLE FOR THE ACCURACY OR COMPLETENESS OF SCANNED COPIES OF THIS PLAN SHEET.

TO ACCOMPANY PLANS DATED _____

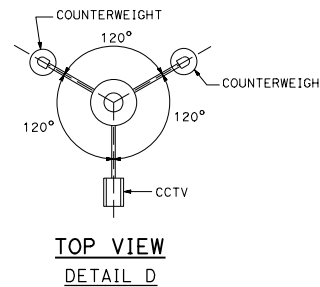
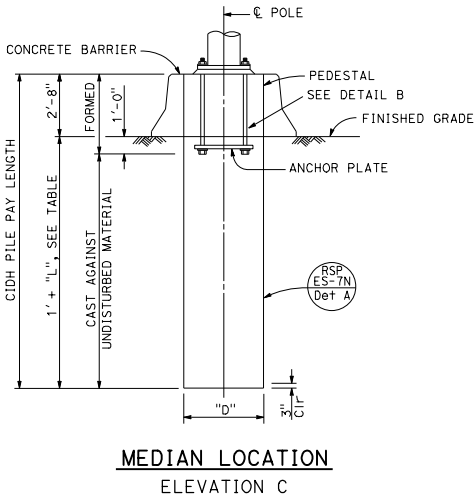
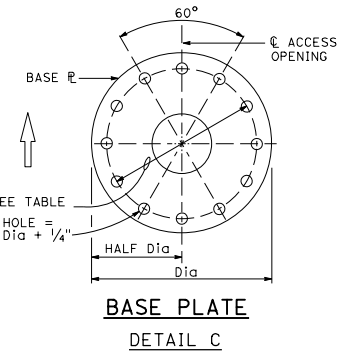
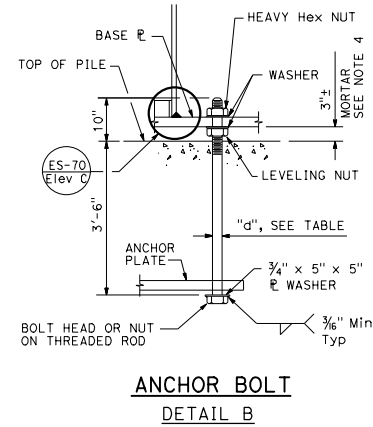
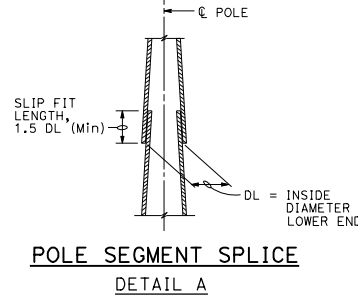
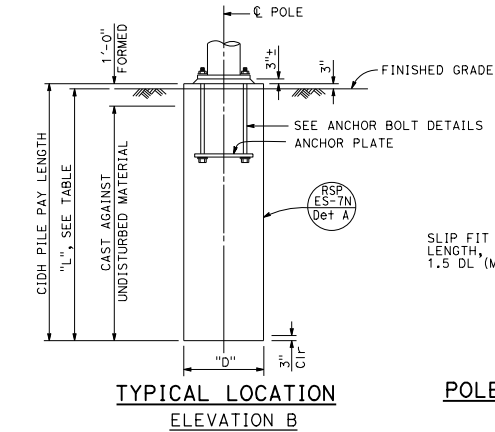
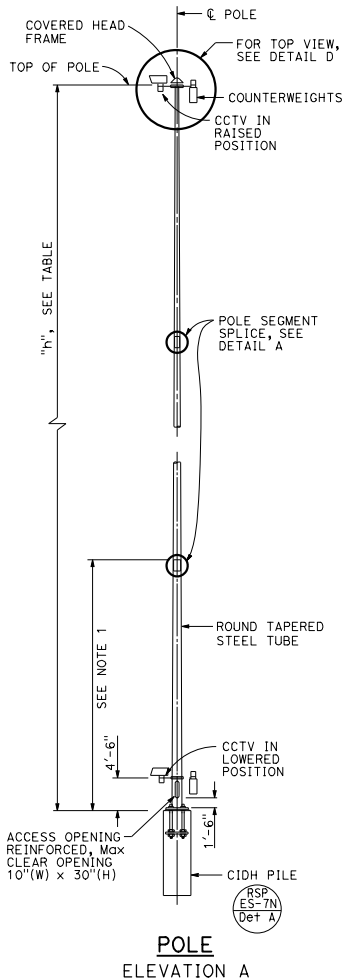

NOTES:

1. Pole details shall suit the lowering device and this foundation plan. Pole details shall be submitted to the Engineer for approval.
2. For closed circuit television details, see Electrical Plans.
3. Foundation design is based on a 3-second wind gust of 100 mph.
4. For central void and drain holes in mortar, see Revised Standard Plan RSP ES-6B detail N.
5. For wind loading see Revised Standard Plan RSP ES-7M.
6. Materials (Structural Steel):
fy = 55,000 psi (tapered steel tube)
fy = 50,000 psi (unless otherwise noted)
7. Access opening shall be located on the downstream side of traffic unless otherwise determined by the Engineer.

STATE OF CALIFORNIA
DEPARTMENT OF TRANSPORTATION

**ELECTRICAL SYSTEMS
(CLOSED CIRCUIT TELEVISION,
50' TO 90' HIGH MAST POLE)**

NO SCALE

RSP ES-16C DATED APRIL 20, 2018 SUPERSEDES RSP ES-16C DATED JULY 15, 2016 AND STANDARD PLAN ES-16C DATED OCTOBER 30, 2015 - PAGE 495 OF THE STANDARD PLANS BOOK DATED 2015.

REVISED STANDARD PLAN RSP ES-16C

2015 REVISED STANDARD PLAN RSP ES-16C

WHEN CCTV IS REQUIRED, CCTV MOUNTING ADAPTER DETAIL SHALL BE SUBMITTED BY THE CONTRACTOR FOR THE ENGINEER'S APPROVAL, SEE 

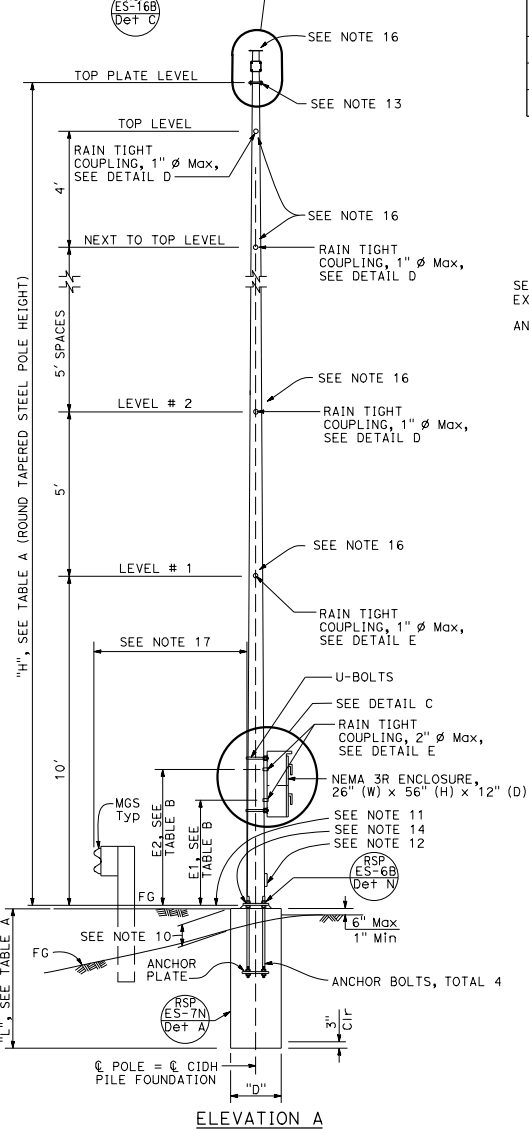

POLE TYPE	POLE DATA				BASE PLATE DATA				CIDH PILE DATA		
	HEIGHT "H"	Min OD		THICKNESS	"C"	THICKNESS	ANCHOR BOLTS SIZE	BC = BOLT CIRCLE	"D"	"L"	
		BASE	TOP							LEVEL GROUND	UP TO 2:1
VDS 30	30'	8"	3 3/4"	0.1793"	1'-1 1/2"	1 1/2"	1 1/2" ϕ x 3'-0"	1'-0"	2'-6"	6'-0"	8'-0"
VDS 35	35'	8 3/4"	3 1/8"	0.1196"	1'-6"	2"		1'-4"	3'-0"	7'-0"	9'-0"
VDS 40	40'	12"	8 3/8"	0.1793"			1'-6"	2"	1'-4"	3'-0"	9'-0"

POLE TYPE	COUPLING	
	E1(Max)	E2(Max)
VDS 30		
VDS 35	3'-6"	4'-9"
VDS 40		

SPREAD FOOTING		
GROUND LEVEL	FOOTING SIZE (LENGTH x WIDTH x DEPTH)	REINFORCEMENT TOP & BOTTOM
UP TO 2:1	10'-0" x 10'-0" x 2'-0"	15 - #5 EW

LOCATION	MAXIMUM TOTAL EPA PER LEVEL (SQ. FEET)	MAXIMUM TOTAL WEIGHT (lb)
LEVEL #1		200
LEVEL #2	14	
LEVEL #3	10 ***	
LEVEL #4 (VDS 35 AND VDS 40 ONLY)		50
LEVEL #5 (VDS 40 ONLY)	2.5	
NEXT TO TOP LEVEL		
TOP LEVEL		
ON TOP PLATE LEVEL **		

* MAXIMUM HORIZONTAL EXTENT BEYOND POLE FACE IS 4 FEET.
** MAXIMUM EXTENT ABOVE TOP PLATE IS 3 FEET.
*** 14 IF LEVEL #1 IS ZERO.

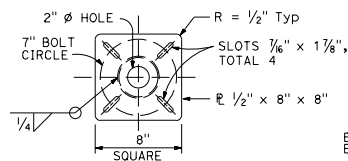
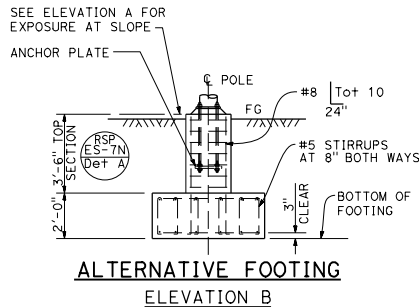

TOP PLATE DETAIL A

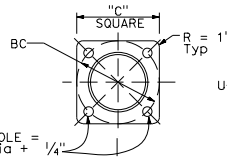

BASE PLATE DETAIL B

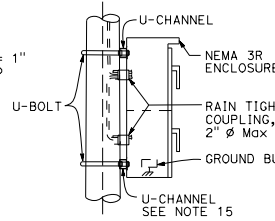

DETAIL C

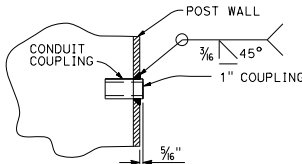

1" COUPLING DETAIL D

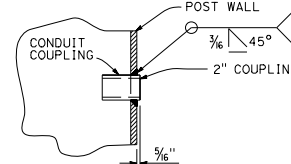

2" COUPLING DETAIL E

DIST	COUNTY	ROUTE	POST MILES TOTAL PROJECT	SHEET TOTAL NO.





Stanley P. Johnson
REGISTERED CIVIL ENGINEER

April 20, 2018
PLANS APPROVAL DATE

THE STATE OF CALIFORNIA OR ITS OFFICERS OR AGENTS SHALL NOT BE RESPONSIBLE FOR THE ACCURACY OR COMPLETENESS OF SCANNED COPIES OF THIS PLAN SHEET.

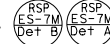
REGISTERED PROFESSIONAL ENGINEER
Stanley P. Johnson
No. 057193
Exp. 3-31-20
CIVIL
STATE OF CALIFORNIA

NOTES:

- All steel shall be galvanized after fabrication.
- The foundation shall be treated as level ground condition if the slope inclination is flatter than 4 : 1 (Horizontal : Vertical)
- For devices mounted and mounting heights, see TABLE B.
- For wind loading see Revised Standard Plan RSP ES-7M.
- Materials (Structural Steel):
a. fy = 55,000 psi (tapered steel tube)
b. fy = 50,000 psi (unless otherwise noted)
- Anchor bolts: fy = 55,000 psi
- Materials (Reinforced Concrete):
a. f'c = 3,600 psi
b. fy = 60,000 psi
- Verify all controlling field dimension before ordering of fabricating any material.
- When no barriers are used, the NEMA 3R enclosure shall be located on the downstream side and perpendicular to the roadway.
1'-3" (Max) for sloped finished grade.
- Bottom of base plate.
- Handhole.  
- Top plate. Install a blank flange on the top plate when closed circuit television is not used.
-  Elev B
- U-channel with bracket.
- Use the manufacturer's Effective Projected Area (EPA) for attachments. Assign attachments to nearest level and sum each level, see Table D for limitations.
- See  thru 

STATE OF CALIFORNIA
DEPARTMENT OF TRANSPORTATION

**ELECTRICAL SYSTEMS
(CLOSED CIRCUIT TELEVISION WITH
VEHICLE DETECTION SYSTEM,
30' TO 40' POLE)**

NO SCALE

RSP ES-16D DATED APRIL 20, 2018 SUPERSEDES RSP ES-16D DATED JULY 15, 2016 AND STANDARD PLAN ES-16D DATED OCTOBER 30, 2015 - PAGE 496 OF THE STANDARD PLANS BOOK DATED 2015.

REVISED STANDARD PLAN RSP ES-16D

2015 REVISED STANDARD PLAN RSP ES-16D

DIST	COUNTY	ROUTE	POST MILES TOTAL PROJECT	SHEET NO.	TOTAL SHEETS

H. R. J.
 REGISTERED ELECTRICAL ENGINEER
 Hamid Zolfaghar
 No. E15636
 Exp. 12-31-19
 ELECTRICAL
 STATE OF CALIFORNIA

April 20, 2018
 PLANS APPROVAL DATE
THE STATE OF CALIFORNIA OR ITS OFFICERS OR AGENTS SHALL NOT BE RESPONSIBLE FOR THE ACCURACY OR COMPLETENESS OF SCANNED COPIES OF THIS PLAN SHEET.

TO ACCOMPANY PLANS DATED _____

NOTES:

1. "PB" for Pull Box or "VT" for Vault.
2. Phone number as specified.
3. $\frac{3}{8}$ " black text.
4. $\frac{1}{4}$ " black text.
5. 1" black text.
6. $\frac{1}{2}$ " black text.

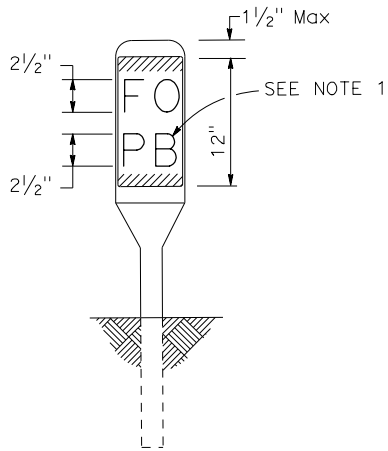

FIBER OPTIC MARKER
FOR VAULTS AND PULL BOXES

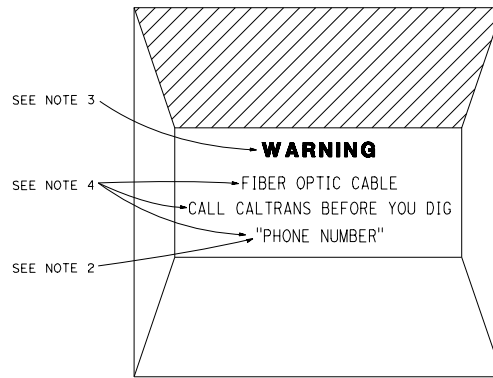

FIBER OPTIC MARKER
FOR PAVED AREAS

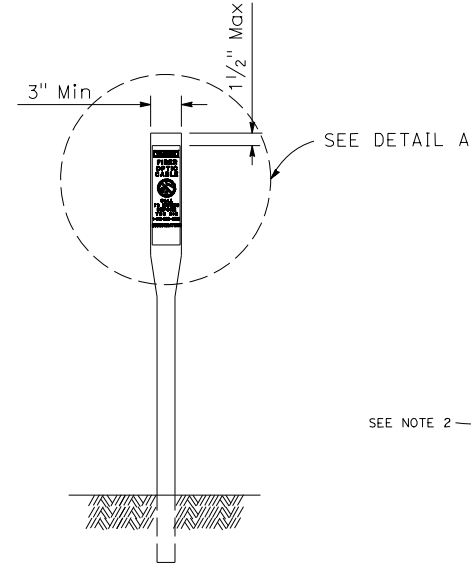

FIBER OPTIC MARKER
FOR UNPAVED AREAS

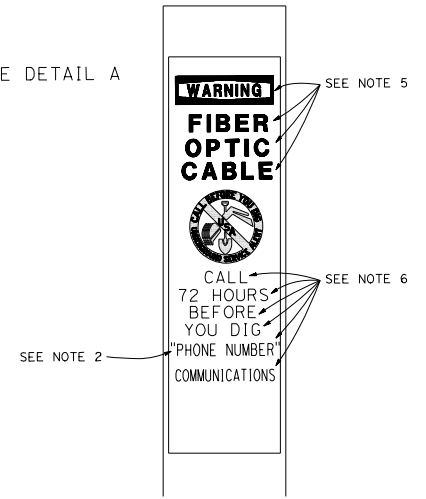

DETAIL A

STATE OF CALIFORNIA
 DEPARTMENT OF TRANSPORTATION
**ELECTRICAL SYSTEMS
 (FIBER OPTIC MARKER DETAILS)**
 NO SCALE

RSP ES-17A DATED APRIL 20, 2018 SUPPLEMENTS THE STANDARD PLANS BOOK DATED 2015.

REVISED STANDARD PLAN RSP ES-17A

2015 REVISED STANDARD PLAN RSP ES-17A

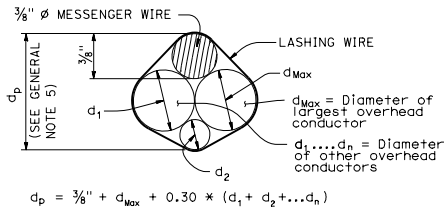

PROJECTED DEPTH OF OVERHEAD BUNDLE, (d_p)

Design: AASHTO Standard Specifications for Structural Supports for Highway Signs, Luminaires and Traffic Signals, Fifth Edition (LTS-5).

GROUP LOAD COMBINATIONS:

- I Dead Load
- II Dead Load + Wind Load
- III Dead Load + 0.5 (Wind Load) + Ice Load
- IV Fatigue: Not used

LOADING:

Wind Loading: 100 mph (3-second gust)
Wind Recurrence Interval: 10 years
Combined height, exposure, and elevated terrain factor = 1.05
(Exposure C, structure is not located on or over the top half of a ridge, hill, or escarpment)

Ice Loading: 3.0 psf on surfaces, 0.60 in radial thickness of ice at a unit weight of 60 pcf on overhead bundles

BASIC DESIGN VALUES:

Timber Poles: $F_b = 1850$ psi
 $F_v = 110$ psi
 $F_{cp} = 230$ psi
 $F_c = 950$ psi
 $E = 1500 \times 10^3$ psi

DESIGN WIRE BREAKING STRENGTHS:

ASTM A475, Utilities Grade, 7 strand modified by termination efficiency factor of 0.8

FOUNDATION DESIGN NOTES:

1. Pole embedment depth design is based on Broms' approximate procedure as described in Article 13.6 of AASHTO LTS-5.
2. Embedment depth is calculated based on following soil parameters.
Cohesive Soil:
Shear strength of soil $c = 1500$ psf.
Cohesionless Soil:
 $\phi = 30$ deg, $\gamma = 120$ pcf.
Soil assumed to be unsaturated.
3. An overload factor of 2.0 and an undercapacity factor of 0.7 were used for safety factor of 2.86.
4. Allowable vertical bearing pressure at the end bearing of poles is 3000 psf at 6 feet or more embedment.
5. Guy wire anchor minimum allowable tension capacity, "0a" = 8,900 lbs.

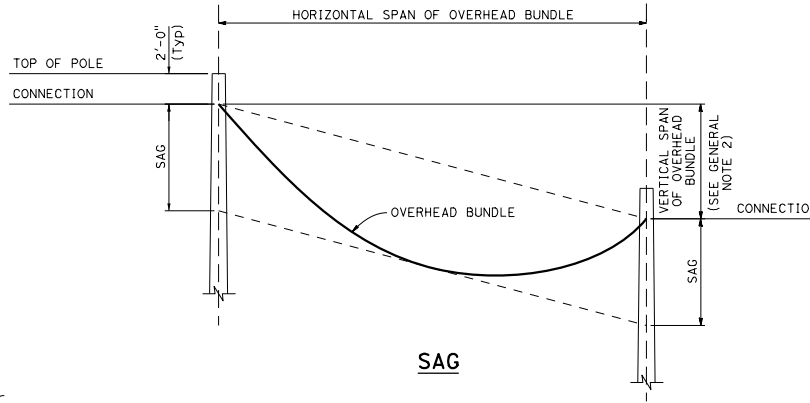

SAG

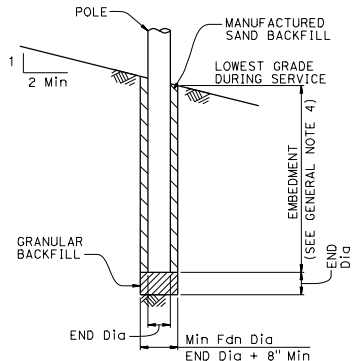

POLE FOUNDATION

GENERAL NOTES:

1. The messenger wire and any combination of overhead conductors must not exceed either a self weight of 3.0 lb/ft or the maximum d in the pole selection tables.
2. The maximum vertical span is 10% of the horizontal span.
3. For poles with adjacent unbalanced horizontal spans, the shortest horizontal span must be at least 50% of the largest horizontal span.
4. Add 2'-0" for slopes above 1V:4H.
5. For a pole supporting multiple spans, calculate d_p for each span and use the largest value.
6. Do not exceed the attachments shown.

DIST	COUNTY	ROUTE	POST MILES TOTAL PROJECT	SHEET TOTAL SHEETS

REGISTERED CIVIL ENGINEER
 Stanley P. Johnson
 No. CS7793
 Exp. 3-31-18
 CIVIL
 STATE OF CALIFORNIA

January 20, 2017
PLANS APPROVAL DATE

THE STATE OF CALIFORNIA OR ITS OFFICERS OR AGENTS SHALL NOT BE RESPONSIBLE FOR THE ACCURACY OR COMPLETENESS OF SCANNED COPIES OF THIS PLAN SHEET.

TO ACCOMPANY PLANS DATED _____

DIAMETERS AND SELF WEIGHT OF OVERHEAD CONDUCTORS

CONDUCTOR OR CABLE TYPE	DIAMETER d (in)	WEIGHT w (plf)
3 CONDUCTOR SIGNAL CABLE (3CSC)	0.400	0.0980
5 CONDUCTOR SIGNAL CABLE (5CSC)	0.500	0.1560
9 CONDUCTOR SIGNAL CABLE (9CSC)	0.650	0.2760
12 CONDUCTOR SIGNAL CABLE (12CSC)	0.800	0.3970
28 CONDUCTOR SIGNAL CABLE (28CSC)	0.900	0.6490
1-#14	0.166	0.0235
1-#12	0.185	0.0330
1-#10	0.210	0.0476
1-#8	0.271	0.0774
1-#6	0.310	0.1130
1-#4	0.359	0.1690
1-#3	0.388	0.2080
1-#2	0.420	0.2560
1-#1	0.498	0.3340
6-CONDUCTOR SIGNAL INTERCONNECT CABLE (SIC)	0.350	0.0860
12-CONDUCTOR SIGNAL INTERCONNECT CABLE (SIC)	0.500	0.1440
DETECTOR LEAD-IN CABLE (DLC)	0.310	0.0440
12 to 48-STRAND FIBER OPTIC CABLE (48FOC)	0.424	0.0600
72-STRAND FIBER OPTIC CABLE (72FOC)	0.484	0.0770
96-STRAND FIBER OPTIC CABLE (96FOC)	0.535	0.1050
144-STRAND FIBER OPTIC CABLE (144FOC)	0.670	0.1890
3/8" ϕ MESSENGER WIRE	0.375	0.2730

STATE OF CALIFORNIA
DEPARTMENT OF TRANSPORTATION
TEMPORARY WOOD POLES
GENERAL NOTES
NO SCALE

RSP ES-18A DATED JANUARY 20, 2017 SUPPLEMENTS THE STANDARD PLANS BOOK DATED 2015.

REVISED STANDARD PLAN RSP ES-18A

2015 REVISED STANDARD PLAN RSP ES-18A

LEGEND

- Wood Pole No Attachments
- A Wood Pole with Attachments
- OH- Overhead Bundle

POLE SELECTION TABLE

		CASE 1N				CASE 2N				CASE 3N				CASE 4N				CASE 5N
		MAXIMUM dp																
		1"	1.5"	2.0"	2.5"	1"	1.5"	2.0"	2.5"	1.0"	1.5"	2.0"	2.5"	1"	1.5"	2.0"	2.5"	N/A
OVERHEAD BUNDLE HORIZONTAL SPAN (Max)	50'	MINIMUM POLE CLASS H-1 H-2 H-2 H-2				4 3 2 1				H-2 H-2 H-3 H-3				H-4 H-4 H-4 H-5				CLASS 1 E = 10'
	100'	POLE EMBEDMENT (E) 11'				10'				11'				12'				
	150'	MINIMUM POLE CLASS H-2 H-3 H-4 H-5				1 H-1 H-2 H-3 H-3				H-4 H-5 H-5 H-6				H-5 H-5 H-6				
	200'	POLE EMBEDMENT (E) 12'				11'				12'				12'				
	250'	MINIMUM POLE CLASS H-4 H-5 H-6				H-1 H-2 H-3 H-5				H-6				H-6				
	300'	POLE EMBEDMENT (E) 12'				12'				12'				12'				
	350'	MINIMUM POLE CLASS H-5 H-6				H-2 H-3 H-5												
	400'	POLE EMBEDMENT (E) 12'				12'												

- ① CCTV camera assembly or vehicle detection system
- ② Overhead bundle consisting of a 3/4" Ø messenger wire, overhead conductors, and lashing wire
- ③ Luminaire with mast arm
- ④ Pedestrian push button assembly or accessible push button assembly
- ⑤ Signal face with 3 indications or single sheet sign panel (10 SQFT Max)
- ⑥ Riser with weather head as required
- ⑦ Pull box as required
- ⑧ Grounding as required
- ⑨ Single flashing beacon or single sheet sign panel (4 SQFT Max)
- ⑩ Single sheet sign panel (4' x 4' Max) or signal face with 3 indications
- ⑪ Flashing beacon control assembly
- ⑫ NEMA 3R enclosure, 26"(W) x 56"(H) x 12"(D) Max dimensions. Max weight including batteries, 450 lbs
- ⑬ 25' SQFT Max total photovoltaic panels mounted as shown as required
- ⑭ 2-12" flashing beacons

NOTES:

1. In addition to other restrictions on maximum horizontal span, this horizontal span must not exceed 100'.
2. Cases 1N, 3N and 4N may substitute the attachments shown in Case 5N if the photovoltaic panel is not included.
3. For Case 1N without an overhead bundle (item ②) use minimum pole class H-1 with E=11'.

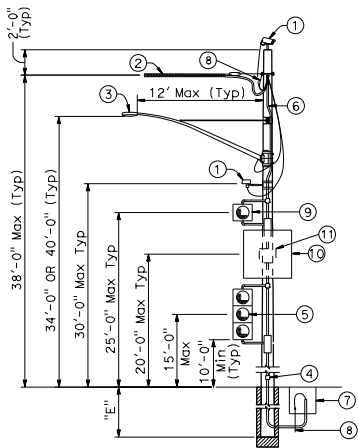

**CASE 1N
POLE AT DEAD END
WITH ATTACHMENTS**

See Note 2

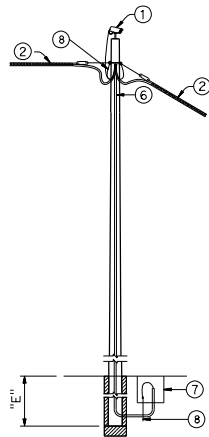

**CASE 2N
POLE AT TANGENT
WITHOUT ATTACHMENTS**

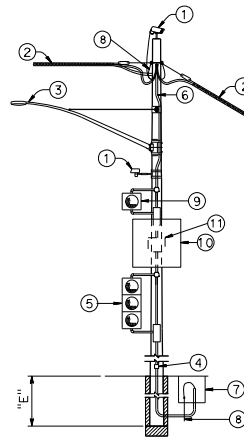

**CASE 3N
POLE AT TANGENT OR CORNER
WITH ATTACHMENTS**

See Note 2

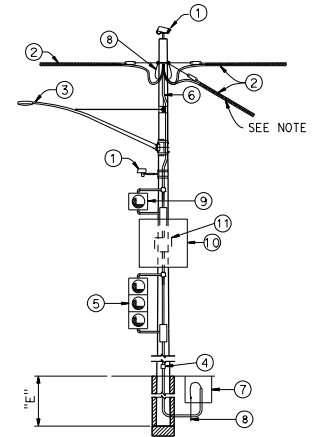

**CASE 4N
POLE AT JUNCTION
WITH ATTACHMENTS**

See Note 2

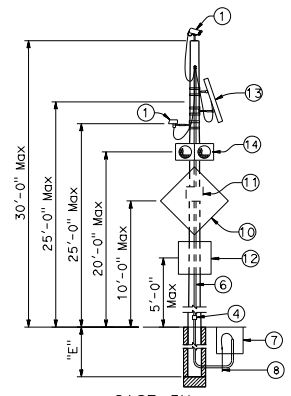

**CASE 5N
POLE WITHOUT OVERHEAD BUNDLE
WITH ATTACHMENTS**

STATE OF CALIFORNIA
DEPARTMENT OF TRANSPORTATION

**TEMPORARY WOOD POLES
NON-GUYED - NO SIGNALS ON SPANS**

NO SCALE

RSP ES-18B DATED JANUARY 20, 2017 SUPPLEMENTS THE STANDARD PLANS BOOK DATED 2015.

REVISED STANDARD PLAN RSP ES-18B

DIST	COUNTY	ROUTE	POST MILES TOTAL PROJECT	SHEET TOTAL SHEETS

Stanley P. Johnson
REGISTERED CIVIL ENGINEER

January 20, 2017
PLANS APPROVAL DATE

Stanley P. Johnson
No. CS7793
Exp. 3-31-18
CIVIL
STATE OF CALIFORNIA

THE STATE OF CALIFORNIA OR ITS OFFICERS OR AGENTS SHALL NOT BE RESPONSIBLE FOR THE ACCURACY OR COMPLETENESS OF SCANNED COPIES OF THIS PLAN SHEET.

TO ACCOMPANY PLANS DATED _____

DIST	COUNTY	ROUTE	POST MILES TOTAL PROJECT	SHEET TOTAL SHEETS

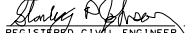
 REGISTERED CIVIL ENGINEER
 No. CS7793
 Exp. 3-31-18
 CIVIL
 STATE OF CALIFORNIA

January 20, 2017
 PLANS APPROVAL DATE
 THE STATE OF CALIFORNIA OR ITS OFFICERS OR AGENTS SHALL NOT BE RESPONSIBLE FOR THE ACCURACY OR COMPLETENESS OF SCANNED COPIES OF THIS PLAN SHEET.

TO ACCOMPANY PLANS DATED _____

LEGEND

-  Wood Pole with Attachments
- OH- Overhead Bundle
- Guy Anchor

POLE SELECTION TABLE

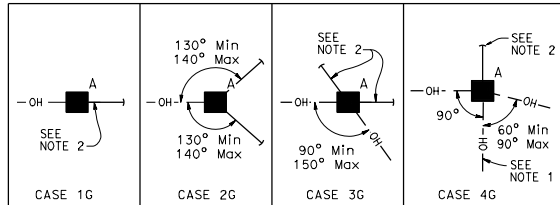

OVERHEAD BUNDLE HORIZONTAL SPAN (Max)	MAXIMUM d _p	1"				1.5"				2.0"				2.5"			
		1"	1.5"	2.0"	2.5"	1"	1.5"	2.0"	2.5"	1"	1.5"	2.0"	2.5"	1"	1.5"	2.0"	2.5"
50'	MINIMUM POLE CLASS	H-1	H-1	H-2	H-2	1	1	1	1	1	1	1	H-1	H-2	H-2	H-3	H-3
100'	POLE EMBEDMENT (E)	10'				9'				9'				11'			
150'	MINIMUM POLE CLASS	H-2	H-2	H-3	H-4	1	H-1	H-1	H-1	1	H-1	H-2	H-2	H-3	H-3	H-4	H-4
200'	POLE EMBEDMENT (E)	11'				9'				9'				12'			
	MINIMUM POLE CLASS	H-3	H-3	H-4	H-5	H-1	H-1	H-2	H-2	H-2	H-3	H-3	H-3	H-4	H-5	H-5	H-6
	POLE EMBEDMENT (E)	11'				9'				9'				12'			
	MINIMUM POLE CLASS	H-4	H-4	H-5	H-6	H-1	H-2	H-3	H-3	H-3	H-3	H-4	H-4	H-5	H-6		
	POLE EMBEDMENT (E)	11'				9'				9'				12'			

- ① CCTV camera assembly or vehicle detection system
- ② Overhead bundle consisting of a 3/8" Ø messenger wire, overhead conductors, and lashing wire
- ③ Luminaire with mast arm
- ④ Pedestrian push button assembly or accessible push button assembly
- ⑤ Signal face with 3 indications or single sheet sign panel (10 SOFT Max)
- ⑥ Riser with weather head as required
- ⑦ Pull box as required
- ⑧ Grounding as required
- ⑨ Single flashing beacon or single sheet sign panel (4 SOFT Max)
- ⑩ Single sheet sign panel (4' x 4' Max) or signal face with 3 indications
- ⑪ Flashing beacon control assembly
- ⑫ 1/2" Ø guy wire with white guy marker and strain insulator (for anchorage see "TEMPORARY WOOD POLES-DETAILS No. 2" sheet)

NOTES:

1. In addition to other restrictions on maximum horizontal span, this horizontal span must not exceed 100'.
2. Guy wire in line with opposing span ± 5°.

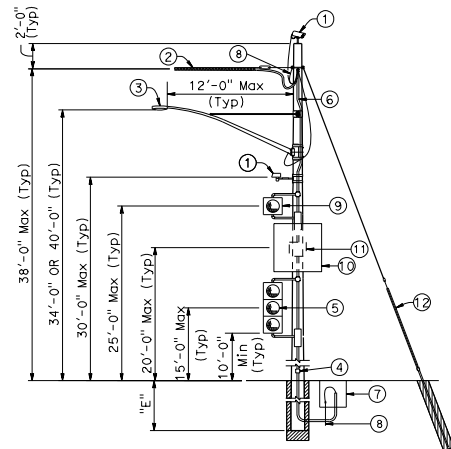

**CASE 1G
POLE AT DEAD END
WITH ATTACHMENTS**

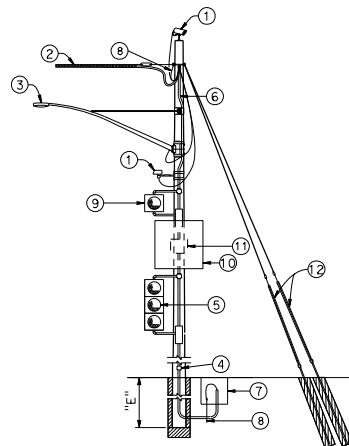

**CASE 2G
POLE AT DEAD END
WITH ATTACHMENTS**

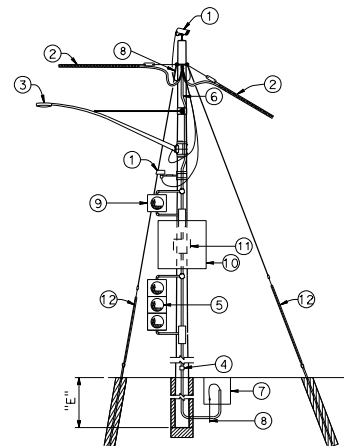

**CASE 3G
POLE AT CORNER
WITH ATTACHMENTS**

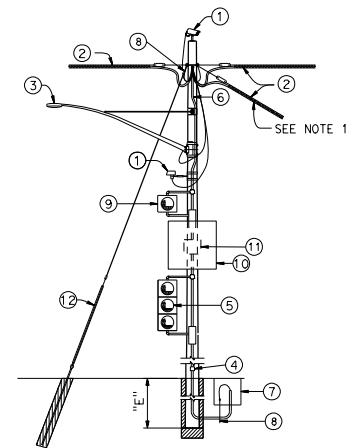

**CASE 4G
POLE AT JUNCTION
WITH ATTACHMENTS**

STATE OF CALIFORNIA
DEPARTMENT OF TRANSPORTATION

**TEMPORARY WOOD POLES
GUYED - NO SIGNALS ON SPANS**

NO SCALE

RSP ES-18C DATED JANUARY 20, 2017 SUPPLEMENTS THE STANDARD PLANS BOOK DATED 2015.

REVISED STANDARD PLAN RSP ES-18C

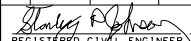

2015 REVISED STANDARD PLAN RSP ES-18C

DIST	COUNTY	ROUTE	POST MILES TOTAL PROJECT	SHEET TOTAL SHEETS

 REGISTERED CIVIL ENGINEER
 No. CS7793
 Exp. 3-31-18
 CIVIL
 STATE OF CALIFORNIA

January 20, 2017
 PLANS APPROVAL DATE
THE STATE OF CALIFORNIA OR ITS OFFICERS OR AGENTS SHALL NOT BE RESPONSIBLE FOR THE ACCURACY OR COMPLETENESS OF SCANNED COPIES OF THIS PLAN SHEET.

LEGEND

-  Wood Pole with Attachments
- TS- Overhead Bundle with Signal Faces (See Note 2)
- OH- Overhead Bundle
-  Guy Anchor

POLE SELECTION TABLE

OVERHEAD BUNDLE HORIZONTAL SPAN Max	MAXIMUM dp	CASE 1GT			CASE 2GT			CASE 3GT		
		1"	1.5"	2.0"	1"	1.5"	2.0"	1"	1.5"	2.0"
50'	MINIMUM POLE CLASS	H-2	H-3	H-3	H-2	H-2	H-2	H-3	H-4	H-4
	POLE EMBEDMENT (E)	10'			10'			11'		
100'	MINIMUM POLE CLASS	H-3	H-3	H-4	H-2	H-3	H-3	H-4	H-4	H-5
	POLE EMBEDMENT (E)	11'			10'			11'		
150'	MINIMUM POLE CLASS	H-3	H-4	H-4	H-2	H-3	H-4	H-4	H-5	H-5
	POLE EMBEDMENT (E)	11'			10'			11'		

NOTES:

- In addition to other restrictions on maximum horizontal span, this horizontal span must not exceed 100'.
- Maximum of 2 SIGNAL FACES per span within the hatched regions indicated by "LOCATION OF SIGNAL FACES".
- Guy wire in line with opposing span $\pm 5^\circ$.

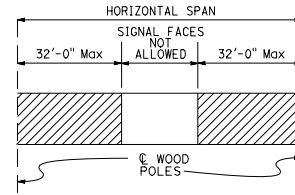

LOCATION OF SIGNAL FACES

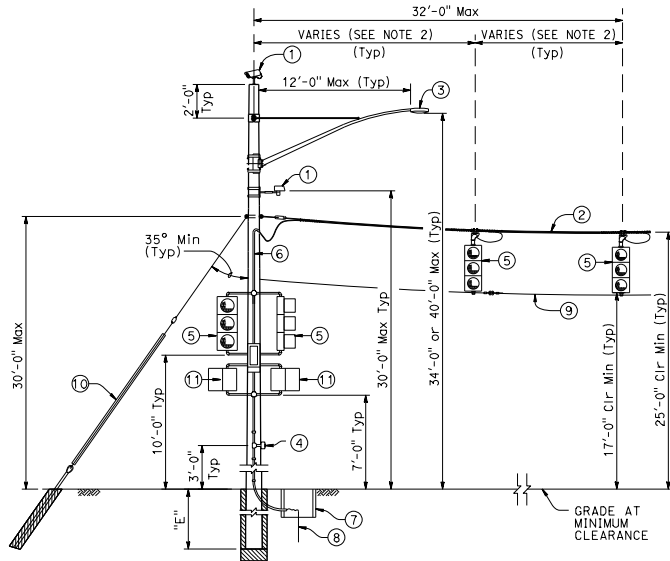

**CASE 1GT
POLE AT DEAD END
WITH ATTACHMENTS**

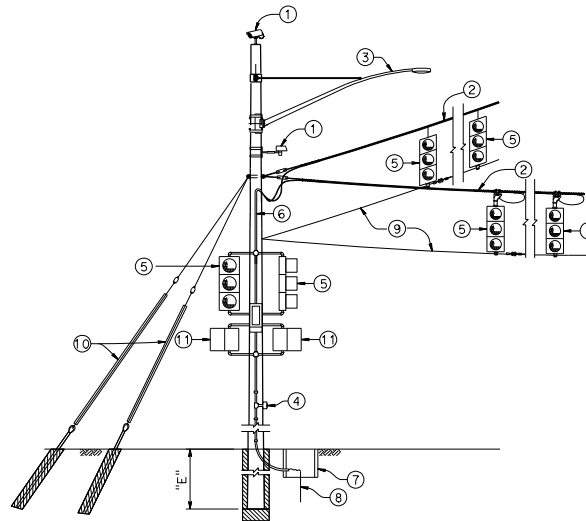

**CASE 2GT
POLE AT CORNER
WITH ATTACHMENTS**

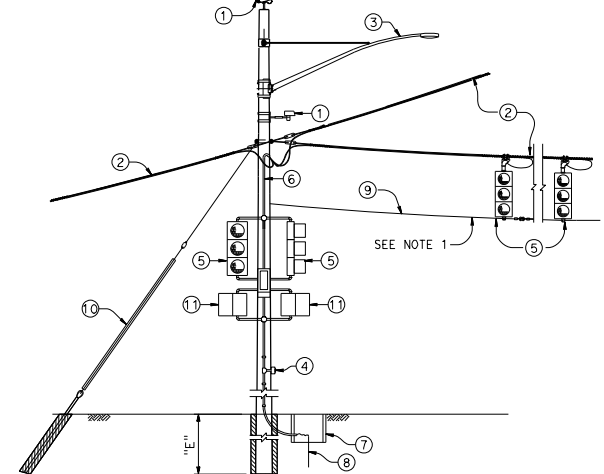

**CASE 3GT
POLE AT JUNCTION WITH ATTACHMENTS**

STATE OF CALIFORNIA
DEPARTMENT OF TRANSPORTATION

**TEMPORARY WOOD POLES
GUYED - WITH SIGNAL FACES ON SPANS**

NO SCALE

RSP ES-18D DATED JANUARY 20, 2017 SUPPLEMENTS THE STANDARD PLANS BOOK DATED 2015.

REVISED STANDARD PLAN RSP ES-18D

2015 REVISED STANDARD PLAN RSP ES-18D

- TO ACCOMPANY PLANS DATED _____
- CCTV camera assembly or vehicle detection system
 - Overhead bundle consisting of $\frac{3}{8}$ " ϕ messenger wire and overhead conductors and lashing wire
 - Luminaire with mast arm
 - Pedestrian push button assembly or accessible push button assembly
 - Signal face with 3 indications or single sheet sign panel (10 SOFT Max)
 - Riser with weather head as required
 - Pull box as required
 - Grounding as required
 - $\frac{3}{8}$ " ϕ tether wire
 - $\frac{1}{2}$ " ϕ guy wire with white guy marker and strain insulator. For anchorage see "TEMPORARY WOOD POLES-DETAILS No. 2" sheet
 - Pedestrian signal head

Dist	COUNTY	ROUTE	POST MILES TOTAL PROJECT	SHEET TOTAL NO. SHEETS

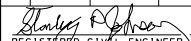
 REGISTERED CIVIL ENGINEER
 No. CS7793
 Exp. 3-31-18
 CIVIL
 STATE OF CALIFORNIA

January 20, 2017
 PLANS APPROVAL DATE
THE STATE OF CALIFORNIA OR ITS OFFICERS OR AGENTS SHALL NOT BE RESPONSIBLE FOR THE ACCURACY OR COMPLETENESS OF SCANNED COPIES OF THIS PLAN SHEET.

LEGEND

- A Wood Pole with Attachments
- TS — Overhead Bundle with Signal Faces (See Note 1)

POLE SELECTION TABLE

		CASE 1NT			
OVERHEAD BUNDLE HORIZONTAL SPAN (Max)	TS	MAXIMUM d_p	1"	1.5"	2.0"
		MINIMUM POLE CLASS	H-5	H-6	H-6
		POLE EMBEDMENT (E)	13'		

- ① CCTV camera assembly or vehicle detection system
- ② Overhead bundle consisting of a $\frac{3}{8}$ " ϕ messenger wire and overhead conductors and lashing wire
- ③ Luminaire with mast arm
- ④ Pedestrian push button assembly or accessible push button assembly
- ⑤ Signal face with 3 indications or single sheet sign panel (10 SQFT Max)
- ⑥ Riser with weather head as required
- ⑦ Pull box as required
- ⑧ Grounding as required
- ⑨ $\frac{3}{8}$ " ϕ tether wire
- ⑩ Pedestrian signal head

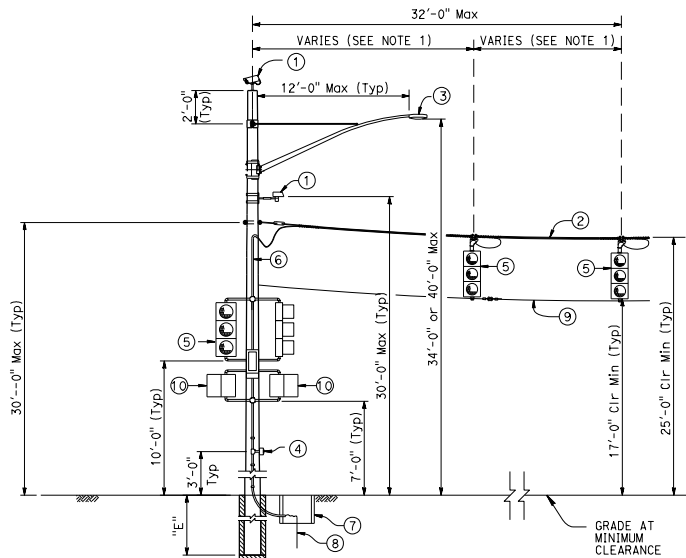

CASE 1NT
**POLE AT DEAD END
WITH ATTACHMENTS**

NOTE:

1. Maximum of 2 SIGNAL FACES per span within the hatched regions indicated by "LOCATION OF SIGNAL FACES".

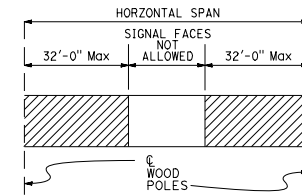

LOCATION OF SIGNAL FACES

STATE OF CALIFORNIA
DEPARTMENT OF TRANSPORTATION
**TEMPORARY WOOD POLES
NON-GUYED-WITH SIGNAL FACES ON SPAN**
NO SCALE

RSP ES-18E DATED JANUARY 20, 2017 SUPPLEMENTS THE STANDARD PLANS BOOK DATED 2015.

REVISED STANDARD PLAN RSP ES-18E

2015 REVISED STANDARD PLAN RSP ES-18E

DIST	COUNTY	ROUTE	POST MILES TOTAL PROJECT	SHEET No.	TOTAL SHEETS

Stanley P. Johnson
 REGISTERED CIVIL ENGINEER
 No. CS7793
 Exp. 3-31-18
 CIVIL
 STATE OF CALIFORNIA

January 20, 2017
 PLANS APPROVAL DATE
 THE STATE OF CALIFORNIA OR ITS OFFICERS
 OR AGENTS SHALL NOT BE RESPONSIBLE FOR
 THE ACCURACY OR COMPLETENESS OF SCANNED
 COPIES OF THIS PLAN SHEET.

TO ACCOMPANY PLANS DATED _____

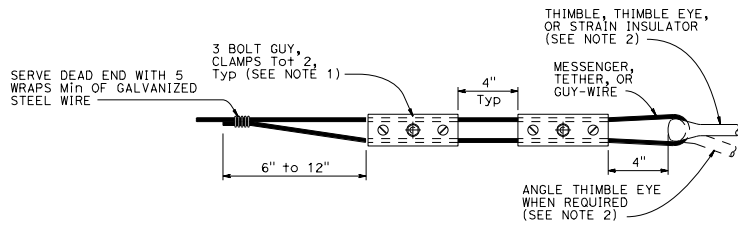

ALTERNATIVE TERMINATION OF MESSENGER WIRES USING GUY CLAMPS

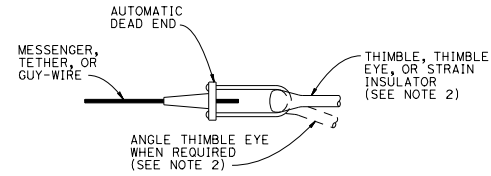

TERMINATION OF WIRES USING AUTOMATIC DEAD END

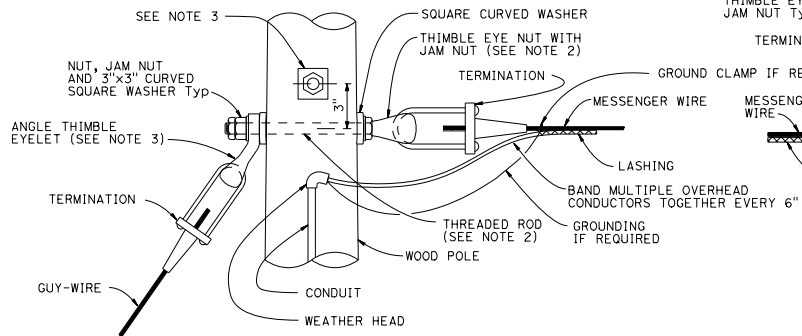

POLE AT DEAD END WITH GUY-WIRE CONNECTION

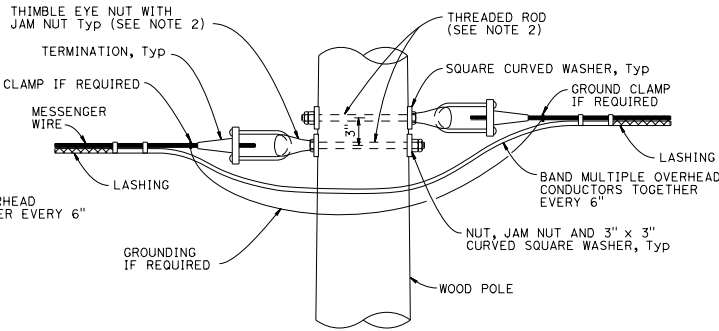

POLE AT TANGENT OR CORNER CONNECTION

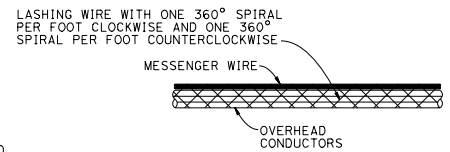

DOUBLE LASHING DETAIL

USE IF d_p IS GREATER THAN $1\frac{1}{2}$ "

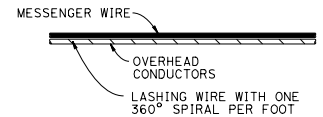

TYPICAL LASHING DETAIL

USE IF d_p IS $1\frac{1}{2}$ " OR LESS

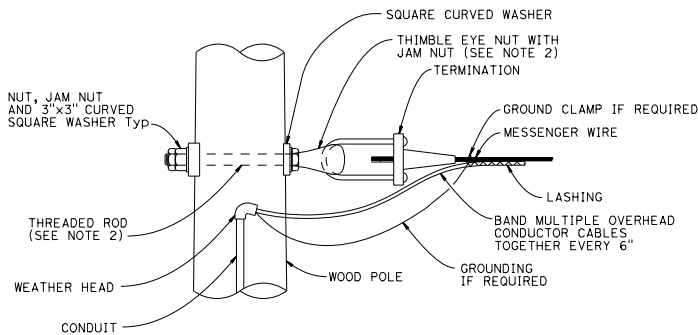

POLE AT DEAD END CONNECTION

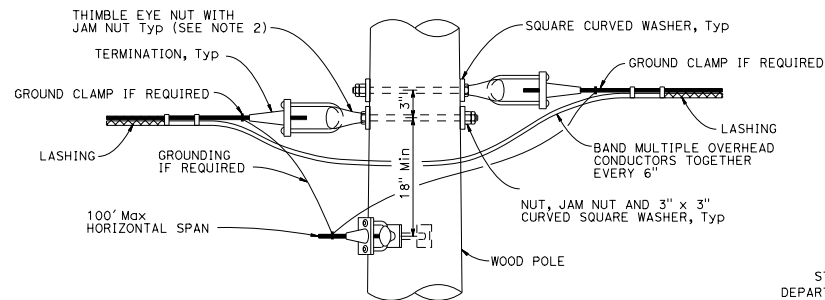

POLE AT JUNCTION CONNECTION

NOTES:

1. For guy wires use 3 clamps.
2. Use $\frac{5}{8}$ " ϕ except $\frac{3}{4}$ " ϕ at guyed wires
3. Install additional angle thimble eyelet at poles with two guy wires.

STATE OF CALIFORNIA
DEPARTMENT OF TRANSPORTATION

**TEMPORARY WOOD POLES
DETAILS No. 1**

NO SCALE

RSP ES-19A DATED JANUARY 20, 2017 SUPPLEMENTS THE STANDARD PLANS BOOK DATED 2015.

REVISED STANDARD PLAN RSP ES-19A

2015 REVISED STANDARD PLAN RSP ES-19A

DIST	COUNTY	ROUTE	POST MILES TOTAL PROJECT	SHEET NO.	TOTAL SHEETS
 REGISTERED CIVIL ENGINEER					
January 20, 2017 PLANS APPROVAL DATE					
No. CS7793 PLAN APPROVAL NO.					
END. 3-31-18 CIVIL					
THE STATE OF CALIFORNIA OR ITS OFFICERS OR AGENTS SHALL NOT BE RESPONSIBLE FOR THE ACCURACY OR COMPLETENESS OF SCANNED COPIES OF THIS PLAN SHEET.					

TO ACCOMPANY PLANS DATED _____

NOTE:

1. For minimum allowable tension capacity of anchors see "Temporary Wood Poles - General Notes" sheet.

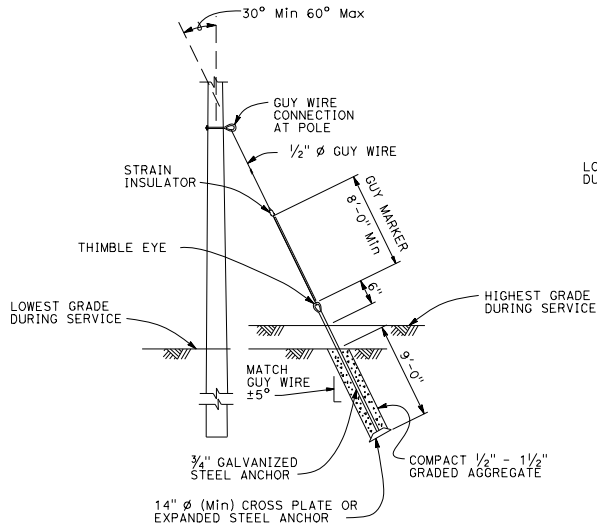

NOTE:
Helical anchor detail may be used in place of expanded steel anchors.

EXPANDED STEEL ANCHOR DETAIL

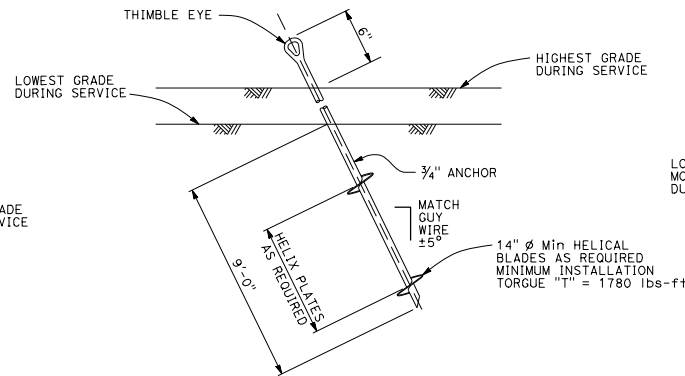

HELICAL ANCHOR DETAIL

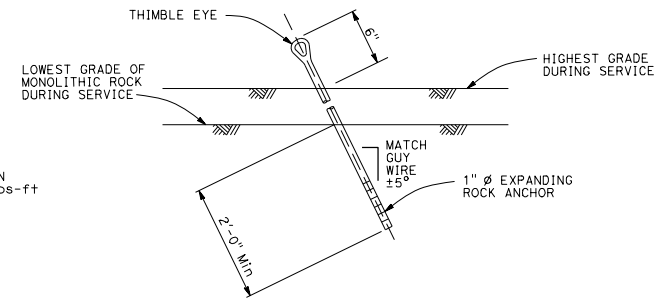

EXPANDING ROCK ANCHOR DETAIL

STATE OF CALIFORNIA
DEPARTMENT OF TRANSPORTATION

**TEMPORARY WOOD POLES
DETAILS No. 2**

NO SCALE

RSP ES-19B DATED JANUARY 20, 2017 SUPPLEMENTS THE STANDARD PLANS BOOK DATED 2015.

REVISED STANDARD PLAN RSP ES-19B

2015 REVISED STANDARD PLAN RSP ES-19B

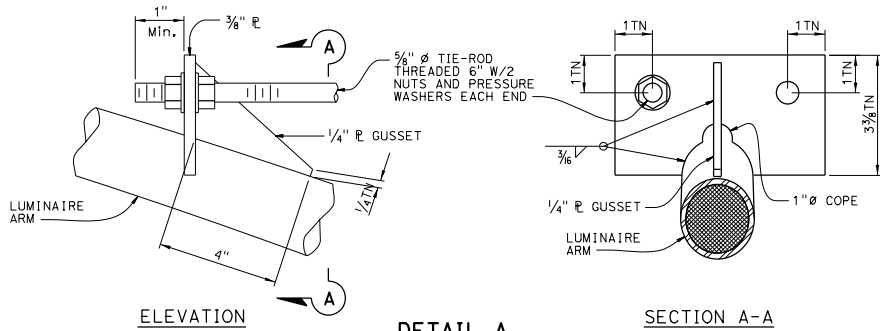

DETAIL A
TIE-ROD AT LUMINAIRE ARM

NOTES:

- Luminaire mast arms must be in compliance with Standard Plan ES-6D with noted modifications.
- Verify pole dimensions at tie-rod attachment height. Fabricate 8" flat bar with "L" dimension to maintain an open gap between flanges in finished installation.
- Not all screw heads and bolt heads are shown for clarity.
- Mast arm not shown for clarity.

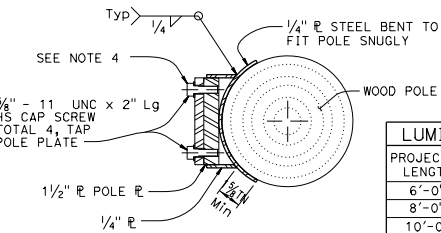

SECTION E-E

PROJECTED LENGTH	N RISE AT POLE	MIN OD POLE	NOMINAL THICKNESS
6'-0"	2'-0"±	3 1/4"	0.1196"
8'-0"	2'-6"±	3 1/2"	
10'-0"	3'-3"±	3 3/4"	
12'-0"	4'-3"±	4 1/4"	

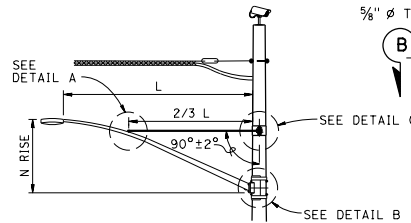

LUMINAIRE MAST ARM

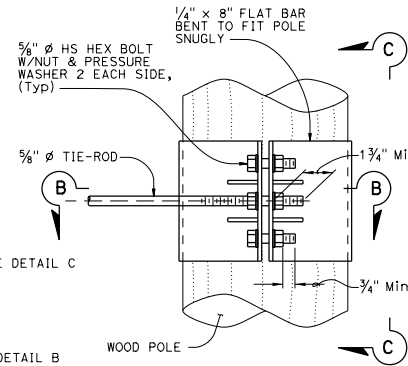

ELEVATION

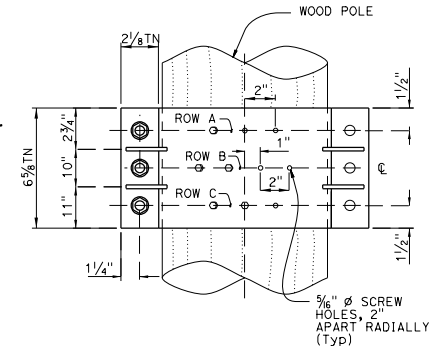

VIEW C-C

NOTE:
Not all screw and bolt heads shown for clarity.

TO ACCOMPANY PLANS DATED _____

DIST	COUNTY	ROUTE	POST MILES TOTAL PROJECT	SHEET TOTAL SHEETS

Stanley P. Johnson
 REGISTERED CIVIL ENGINEER
 No. CS7793
 Exp. 3-31-18
 CIVIL
 STATE OF CALIFORNIA

January 20, 2017
 PLANS APPROVAL DATE
 THE STATE OF CALIFORNIA OR ITS OFFICERS OR AGENTS SHALL NOT BE RESPONSIBLE FOR THE ACCURACY OR COMPLETENESS OF SCANNED COPIES OF THIS PLAN SHEET.

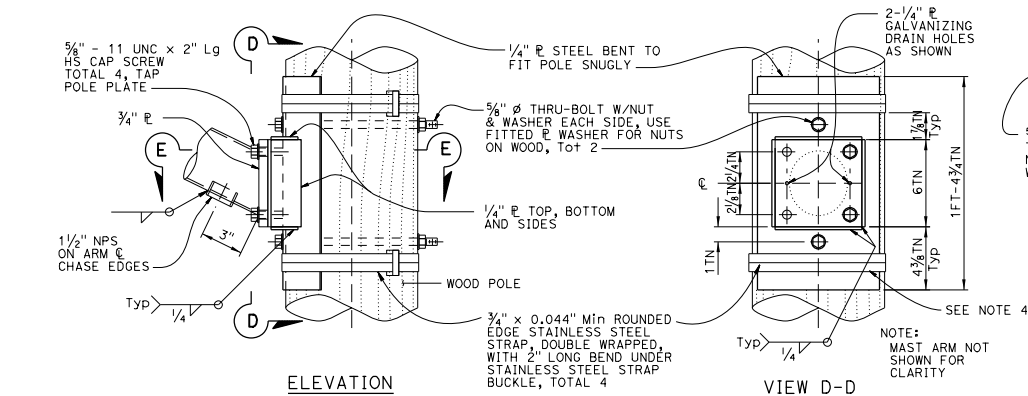

ELEVATION

VIEW D-D

DETAIL B
ARM CONNECTION DETAILS

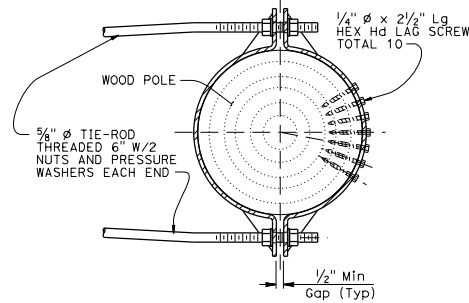

SECTION B-B

DETAIL C
TIE-ROD AT POLE

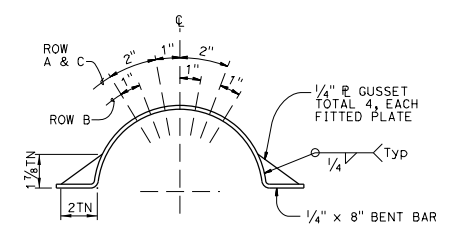



LAG SCREW AND GUSSET PLATE LAYOUT

STATE OF CALIFORNIA
DEPARTMENT OF TRANSPORTATION
TEMPORARY WOOD POLES
DETAILS No. 3
NO SCALE

RSP ES-19C DATED JANUARY 20, 2017 SUPPLEMENTS THE STANDARD PLANS BOOK DATED 2015.

REVISED STANDARD PLAN RSP ES-19C

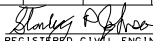
2015 REVISED STANDARD PLAN RSP ES-19C

DIST	COUNTY	ROUTE	POST MILES TOTAL PROJECT	SHEET TOTAL SHEETS
 REGISTERED CIVIL ENGINEER				
January 20, 2017 PLANS APPROVAL DATE				
				
THE STATE OF CALIFORNIA OR ITS OFFICERS OR AGENTS SHALL NOT BE RESPONSIBLE FOR THE ACCURACY OR COMPLETENESS OF SCANNED COPIES OF THIS PLAN SHEET.				

TO ACCOMPANY PLANS DATED _____

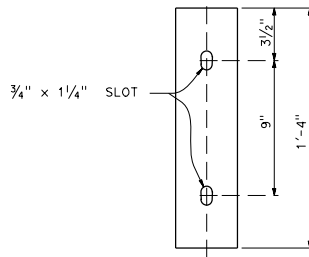
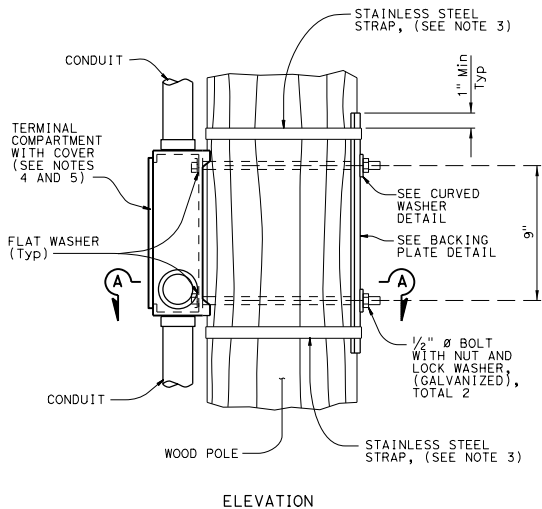

ELEVATION

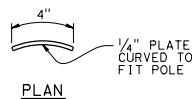

PLAN

BACKING PLATE
DETAIL

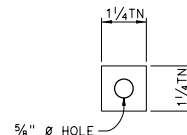

ELEVATION

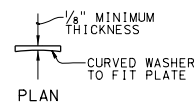

PLAN

CURVED WASHER
DETAIL

NOTES:

1. Verify pole dimensions at terminal compartment for fabrication of backing plate and curved washer.
2. Backing plate to be galvanized after fabrication.
3. 3/4" x 0.044" minimum, rounded edge stainless steel straps, double wrapped with 2" long bend under stainless steel strap buckle.
4. For miscellaneous details for signal mounting not shown see Standard Plan ES-4D.
5. If the terminal compartment has a cable entry guide on the rear face, remove the cable entry guide to a level that will not interfere with the wood post. Close any unused cable entry locations with raintight cap.

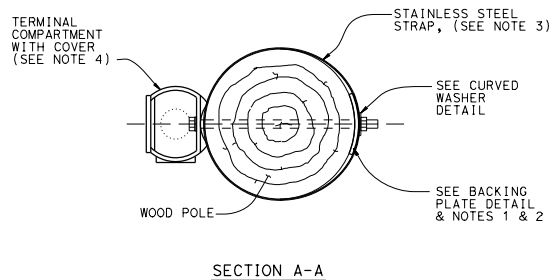

SECTION A-A

**SIDE MOUNTING
TERMINAL COMPARTMENT**

STATE OF CALIFORNIA
DEPARTMENT OF TRANSPORTATION

**TEMPORARY WOOD POLES
DETAILS No. 4**

NO SCALE

RSP ES-19D DATED JANUARY 20, 2017 SUPPLEMENTS THE STANDARD PLANS BOOK DATED 2015.

REVISED STANDARD PLAN RSP ES-19D

2015 REVISED STANDARD PLAN RSP ES-19D

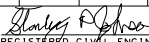
DIST	COUNTY	ROUTE	POST MILES TOTAL PROJECT	SHEET TOTAL SHEETS
 REGISTERED CIVIL ENGINEER No. CS7793 PLANS APPROVAL DATE January 20, 2017 THE STATE OF CALIFORNIA OR ITS OFFICERS OR AGENTS SHALL NOT BE RESPONSIBLE FOR THE ACCURACY OR COMPLETENESS OF SCANNED COPIES OF THIS PLAN SHEET.				
REGISTERED PROFESSIONAL ENGINEER Stanley P. Johnson No. CS7793 EXP. 3-31-18 CIVIL STATE OF CALIFORNIA				

TO ACCOMPANY PLANS DATED _____

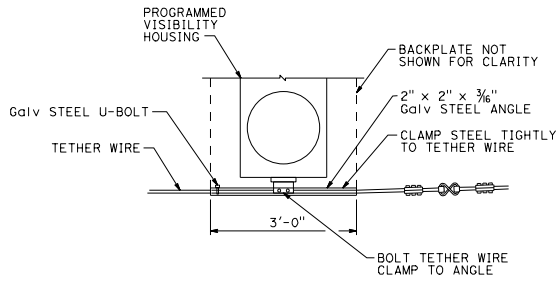

TETHER WIRE ATTACHMENT FOR PROGRAMMED VISIBILITY SIGNAL FACE

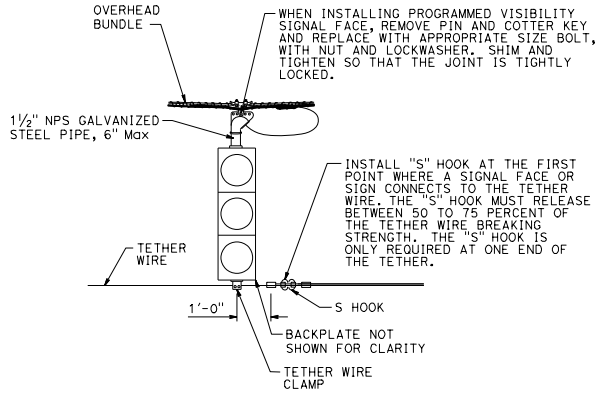

SIGNAL FACE SUPPORT

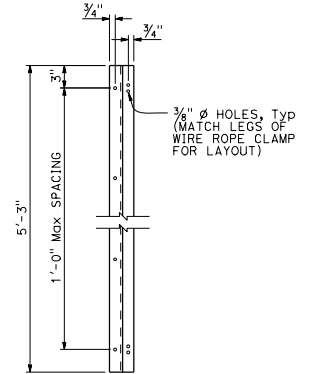

Z-BAR ELEVATION

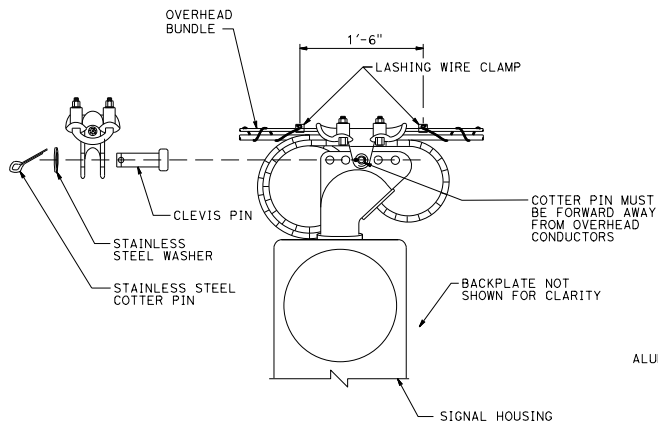

MESSENGER WIRE CLAMP COTTER PIN DETAIL

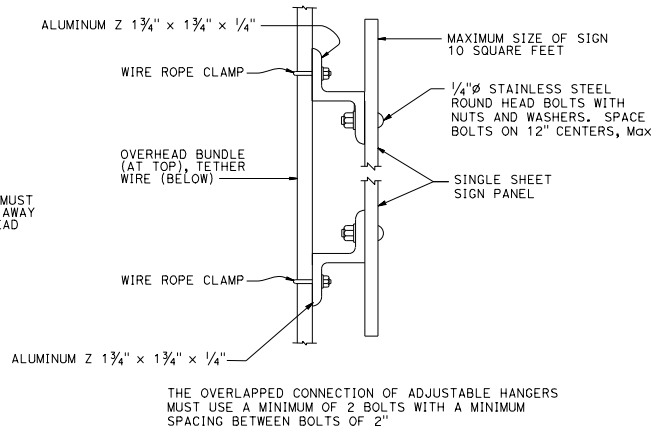

SIGN MOUNTING DETAIL

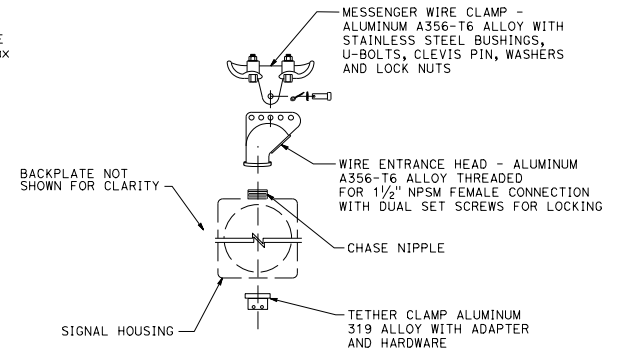

SIGNAL FACE SUPPORT EXPLODED VIEW

STATE OF CALIFORNIA
DEPARTMENT OF TRANSPORTATION
TEMPORARY WOOD POLES
DETAILS No. 5
NO SCALE

RSP ES-19E DATED JANUARY 20, 2017 SUPPLEMENTS THE STANDARD PLANS BOOK DATED 2015.

REVISED STANDARD PLAN RSP ES-19E

2015 REVISED STANDARD PLAN RSP ES-19E

EXISTING	NEW	ITEM DESCRIPTION	EXISTING	NEW	ITEM DESCRIPTION
		WATER METER (WM)			GATE VALVE (GV)
		BACKFLOW PREVENTER ASSEMBLY (BPA)			BALL VALVE (BV)
		BACKFLOW PREVENTER ENCLOSURE (BPE)			QUICK COUPLING VALVE (QCV)
		BOOSTER PUMP (BP)			CAM COUPLER ASSEMBLY (CCA)
		TRUCK LOADING STANDPIPE (TLS)			GARDEN VALVE ASSEMBLY (GARVA)
		FLOW SENSOR (FS)			PRESSURE REGULATING VALVE (PRV)
		MASTER IRRIGATION CONTROLLER (MIC)			PRESSURE RELIEF VALVE (PRLV)
		AUXILIARY IRRIGATION CONTROLLER (AIC)			FLOW CONTROL VALVE (FCV)
		IRRIGATION CONTROLLER (IC) IRRIGATION CONTROLLER (IC) (BATTERY) IRRIGATION CONTROLLER (IC) (SOLAR) IRRIGATION CONTROLLER (IC) (TWO WIRE)			COMBINATION AIR RELEASE VALVE (CARV)
		IRRIGATION CONTROLLER(S) IN CONTROLLER ENCLOSURE CABINET (ICC)			CHECK VALVE (CV)
		ARMOR-CLAD CONDUCTORS (ACC)			FLUSH VALVE (FV)
		CONTROL AND NEUTRAL CONDUCTORS (CNC)			EXISTING NOZZLE LINE W/TURNING UNION
		IRRIGATION CONDUIT			EXISTING IRRIGATION SYSTEM
		IRRIGATION SLEEVE			EXISTING IRRIGATION SYSTEM TO BE REMOVED
		DUCTILE IRON PIPE (SUPPLY LINE) (MAIN) (DIP)			CHAIN LINK GATE
		GALVANIZED STEEL PIPE (SUPPLY LINE) (MAIN) (GSP)			QUICK COUPLING VALVE W/SPRINKLER PROTECTOR
		GALVANIZED STEEL PIPE (SUPPLY LINE) (LATERAL) (GSP)			SPRINKLER W/SPRINKLER PROTECTOR
		PLASTIC PIPE (SUPPLY LINE) (MAIN)			CONNECT TO EXISTING SYSTEM
		PLASTIC PIPE (SUPPLY LINE) (LATERAL)			CAP
		COPPER PIPE (SUPPLY LINE)			CAP EXISTING
		DRIP IRRIGATION TUBING			FIBER ROLL
		REMOTE CONTROL VALVE (RCV) REMOTE CONTROL VALVE (MASTER) (RCVM) REMOTE CONTROL VALVE (MASTER) W/FLOW METER (RCVMF)			COMPOST SOCK
		REMOTE CONTROL VALVE W/PRESSURE REGULATOR (RCVP)			
		EXISTING MANUAL CONTROL VALVE (MCV)			
		DRIP VALVE ASSEMBLY (DVA)			
		WYE STRAINER ASSEMBLY (WSA)			

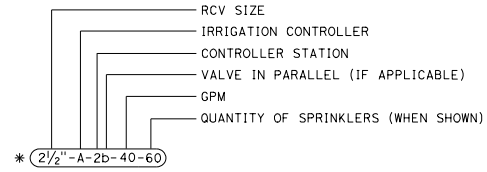

VALVE CODE

* VALVE CODES FOR EXISTING VALVES ARE SHOWN IN A DASHED ENCLOSURE.

DIST	COUNTY	ROUTE	POST MILES TOTAL PROJECT	SHEET TOTAL SHEETS

LICENSED LANDSCAPE ARCHITECT
 July 15, 2016
 PLANS APPROVAL DATE
THE STATE OF CALIFORNIA OR ITS OFFICERS OR AGENTS SHALL NOT BE RESPONSIBLE FOR THE ACCURACY OR COMPLETENESS OF SCANNED COPIES OF THIS PLAN SHEET.

TO ACCOMPANY PLANS DATED _____



2015 REVISED STANDARD PLAN RSP H1



STATE OF CALIFORNIA
DEPARTMENT OF TRANSPORTATION

LANDSCAPE AND EROSION CONTROL SYMBOLS

NO SCALE

RSP H1 DATED JULY 15, 2016 SUPERSEDES STANDARD PLAN H1
DATED OCTOBER 30, 2015 - PAGE 230 OF THE STANDARD PLANS BOOK DATED 2015.

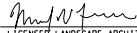
REVISED STANDARD PLAN RSP H1

DIST	COUNTY	ROUTE	POST MILES TOTAL PROJECT	SHEET TOTAL SHEETS
 LICENSED LANDSCAPE ARCHITECT July 21, 2017 PLANS APPROVAL DATE <small>THE STATE OF CALIFORNIA OR ITS OFFICERS OR AGENTS SHALL NOT BE RESPONSIBLE FOR THE ACCURACY OR COMPLETENESS OF SCANNED COPIES OF THIS PLAN SHEET.</small>				
				

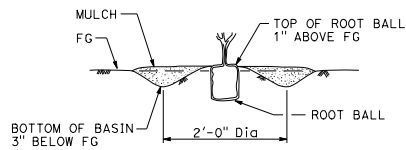

SECTION
(Flat Area)

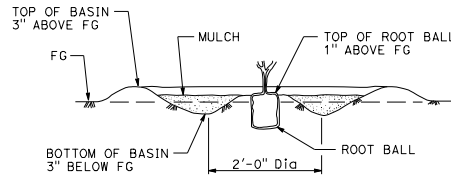

SECTION
(Flat Area)

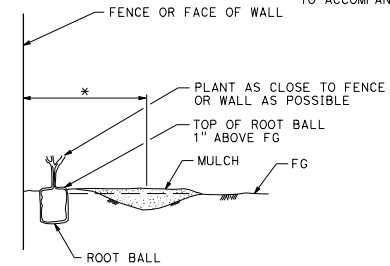

SECTION
(Flat Area)

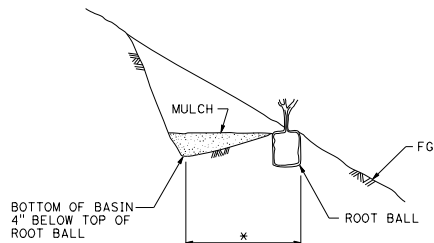

SECTION
(Slope Area)
BASIN TYPE I

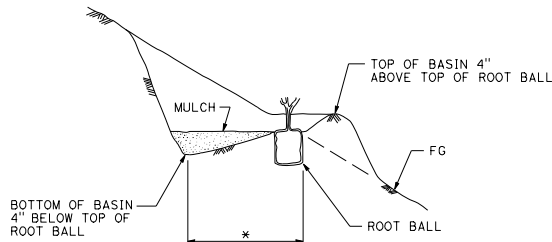

SECTION
(Slope Area)
BASIN TYPE II

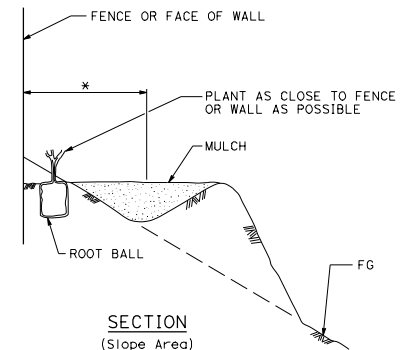

SECTION
(Slope Area)
BASIN TYPE III

* Basin area equivalent to 2'-0" Dia

TO ACCOMPANY PLANS DATED _____

STATE OF CALIFORNIA
DEPARTMENT OF TRANSPORTATION
LANDSCAPE DETAILS

NO SCALE

RSP H2 DATED JULY 21, 2017 SUPERSEDES STANDARD PLAN H2 DATED OCTOBER 30, 2015 - PAGE 231 OF THE STANDARD PLANS BOOK DATED 2015.
REVISED STANDARD PLAN RSP H2

DIST	COUNTY	ROUTE	POST MILES TOTAL PROJECT	SHEET NO.	TOTAL SHEETS
<p><i>Michael J. Ferraro</i> LICENSED LANDSCAPE ARCHITECT</p> <p>July 21, 2017 PLANS APPROVAL DATE</p> <p><small>THE STATE OF CALIFORNIA OR ITS OFFICERS OR AGENTS SHALL NOT BE RESPONSIBLE FOR THE ACCURACY OR COMPLETENESS OF SCANNED COPIES OF THIS PLAN SHEET.</small></p>					
					

TO ACCOMPANY PLANS DATED _____

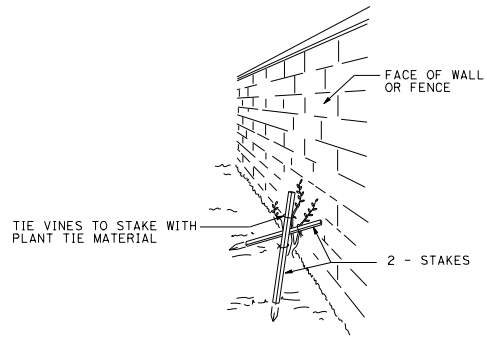

PERSPECTIVE
VINE STAKING

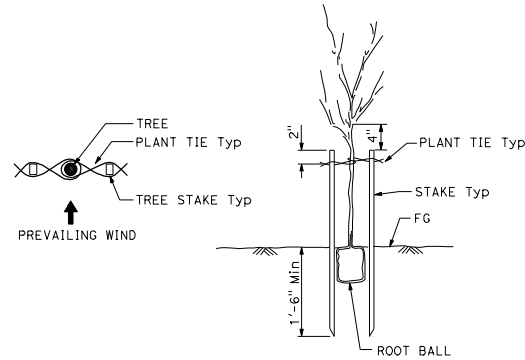

TREE STAKING

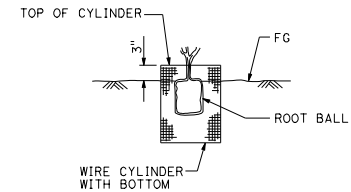

SECTION
ROOT PROTECTOR

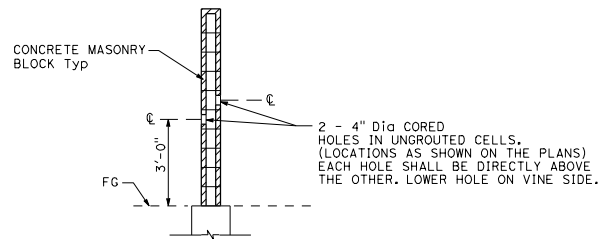

SECTION
CORE HOLE (VINE)

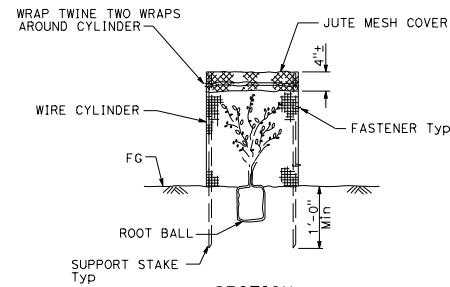

SECTION
FOLIAGE PROTECTOR

STATE OF CALIFORNIA
DEPARTMENT OF TRANSPORTATION
LANDSCAPE DETAILS
NO SCALE

RSP H3 DATED JULY 21, 2017 SUPERSEDES STANDARD PLAN H3 DATED
OCTOBER 30, 2015 - PAGE 232 OF THE STANDARD PLANS BOOK DATED 2015.
REVISED STANDARD PLAN RSP H3

DIST	COUNTY	ROUTE	POST MILES TOTAL PROJECT	SHEET TOTAL SHEETS

 LICENSED LANDSCAPE ARCHITECT
 July 21, 2017
 PLANS APPROVAL DATE
THE STATE OF CALIFORNIA OR ITS OFFICERS OR AGENTS SHALL NOT BE RESPONSIBLE FOR THE ACCURACY OR COMPLETENESS OF SCANNED COPIES OF THIS PLAN SHEET.

TO ACCOMPANY PLANS DATED _____

NOTES:

1. Install tree well sprinkler assembly on up-hill side of plant when on slope.
2. Install bubbler within basin.

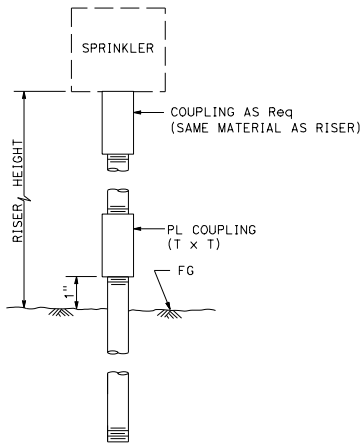

**ELEVATION
RISER TYPE I**

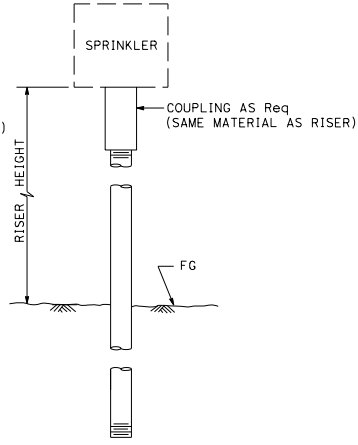

**ELEVATION
RISER TYPE II**

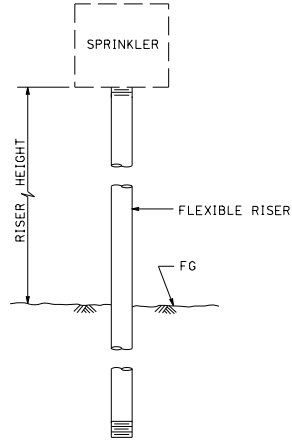

**ELEVATION
RISER TYPE III**

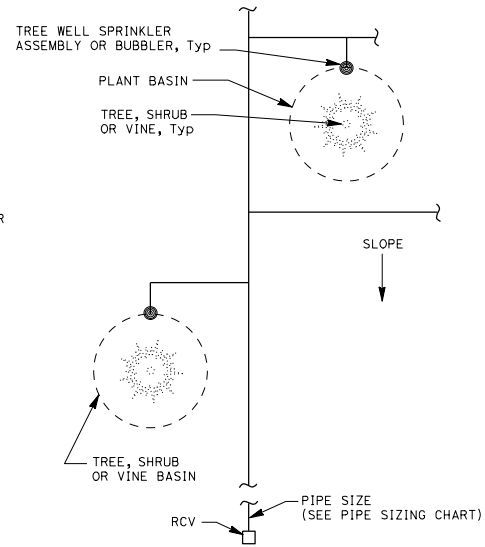

PLAN

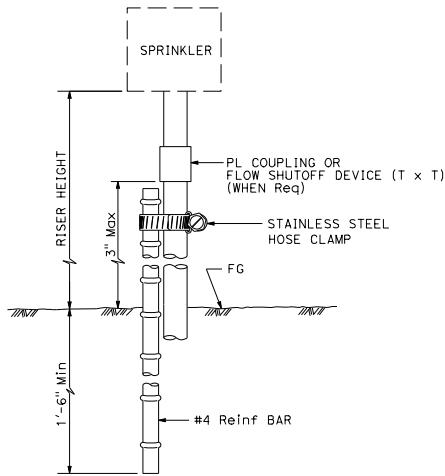

**ELEVATION
RISER TYPE IV**

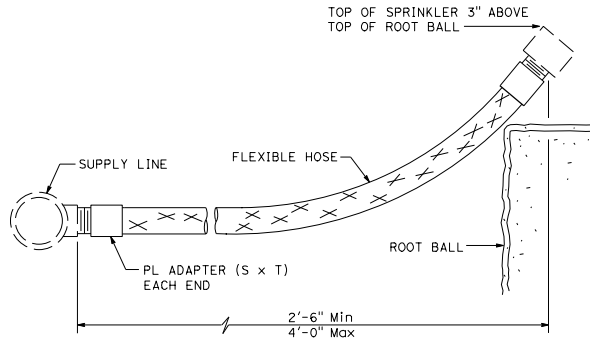

**ELEVATION
RISER TYPE V**

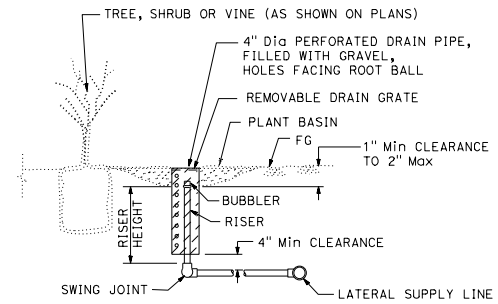

**SECTION
TREE WELL SPRINKLER ASSEMBLY**

STATE OF CALIFORNIA
DEPARTMENT OF TRANSPORTATION
**LANDSCAPE DETAILS
(RISER SPRINKLER ASSEMBLY)**
NO SCALE

RSP H4 DATED JULY 21, 2017 SUPERSEDES RSP H4 DATED JULY 15, 2016 AND STANDARD PLAN H4 DATED OCTOBER 30, 2015 - PAGE 233 OF THE STANDARD PLANS BOOK DATED 2015.

REVISED STANDARD PLAN RSP H4

DIST	COUNTY	ROUTE	POST MILES TOTAL PROJECT	SHEET NO.	TOTAL SHEETS

Paul W. Ferraro
 LICENSED LANDSCAPE ARCHITECT
 July 21, 2017
 PLANS APPROVAL DATE
THE STATE OF CALIFORNIA OR ITS OFFICERS OR AGENTS SHALL NOT BE RESPONSIBLE FOR THE ACCURACY OR COMPLETENESS OF SCANNED COPIES OF THIS PLAN SHEET.



TO ACCOMPANY PLANS DATED _____

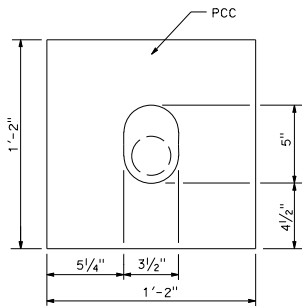

PLAN

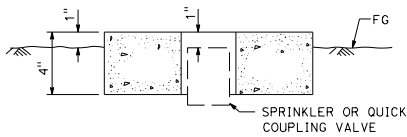

SECTION

SPRINKLER PROTECTOR TYPE I

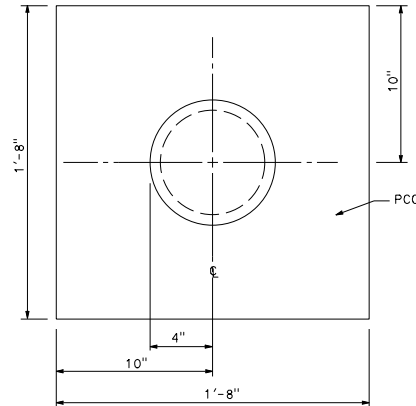

PLAN

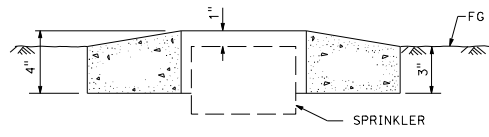

SECTION

SPRINKLER PROTECTOR TYPE II

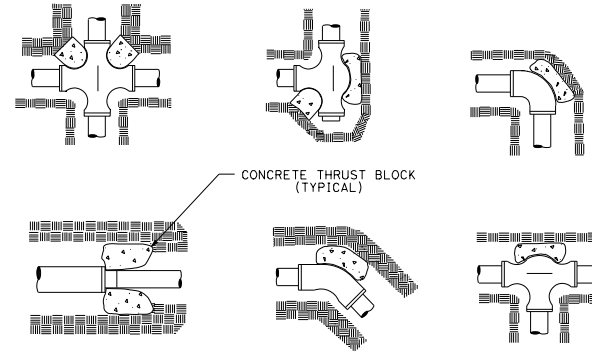

TYPICAL THRUST BLOCKS

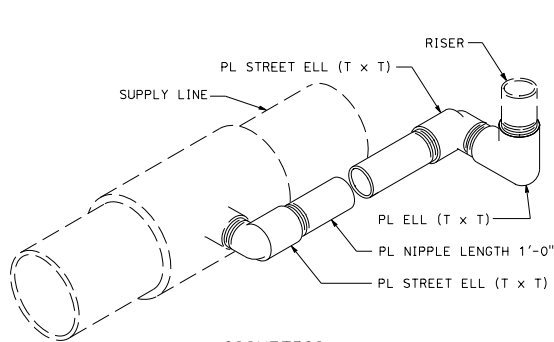

ISOMETRIC

SWING JOINT TYPE I

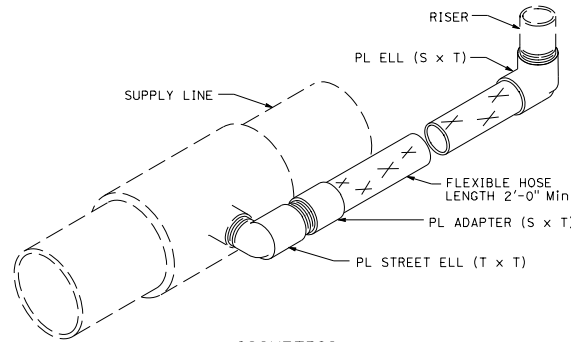

ISOMETRIC

SWING JOINT TYPE II

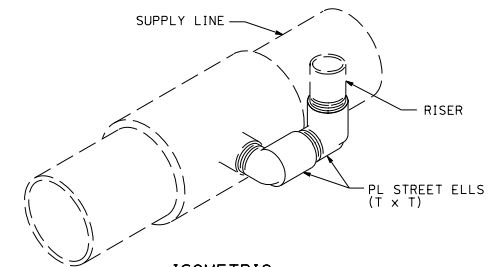

ISOMETRIC

SWING JOINT TYPE III

STATE OF CALIFORNIA
DEPARTMENT OF TRANSPORTATION
**LANDSCAPE DETAILS
(SWING JOINT AND PROTECTOR)**

NO SCALE

RSP H5 DATED JULY 21, 2017 SUPERSEDES RSP H5 DATED JULY 15, 2016 AND STANDARD PLAN H5 DATED OCTOBER 30, 2015 - PAGE 234 OF THE STANDARD PLANS BOOK DATED 2015.

REVISED STANDARD PLAN RSP H5

Dist	COUNTY	ROUTE	POST MILES TOTAL PROJECT	SHEET TOTAL NO. SHEETS
<p>_____ LICENSED LANDSCAPE ARCHITECT July 21, 2017 PLANS APPROVAL DATE THE STATE OF CALIFORNIA OR ITS OFFICERS OR AGENTS SHALL NOT BE RESPONSIBLE FOR THE ACCURACY OR COMPLETENESS OF SCANNED COPIES OF THIS PLAN SHEET.</p>				

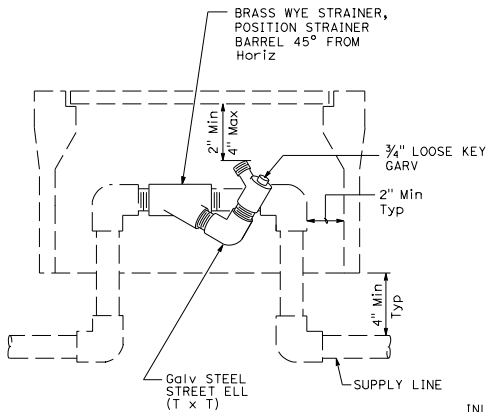

ELEVATION
WYE STRAINER ASSEMBLY

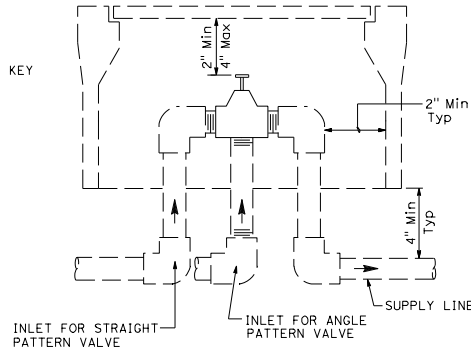

ELEVATION
VALVE

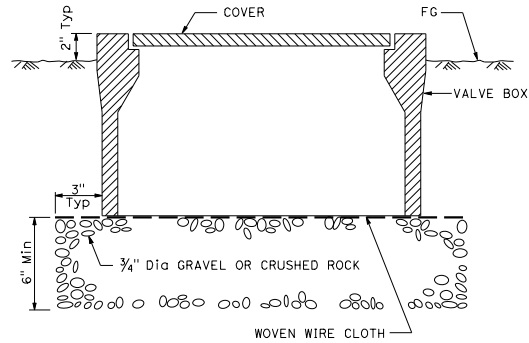

SECTION
VALVE BOX

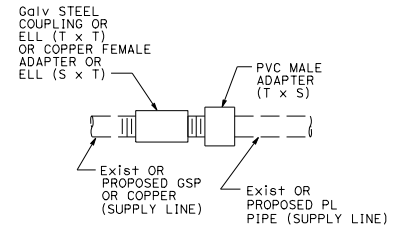

**GALVANIZED OR COPPER PIPE
CONNECTION TO PLASTIC PIPE**

TO ACCOMPANY PLANS DATED _____

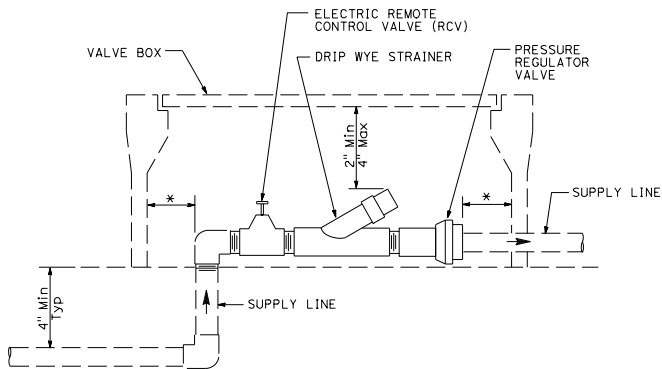

ELEVATION
DRIP VALVE ASSEMBLY

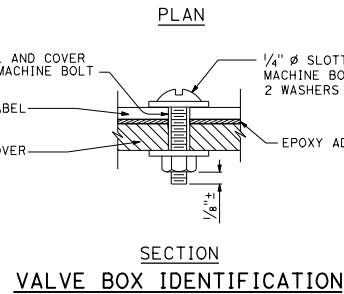
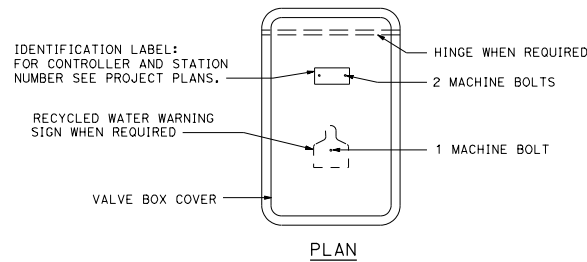

SECTION
VALVE BOX IDENTIFICATION

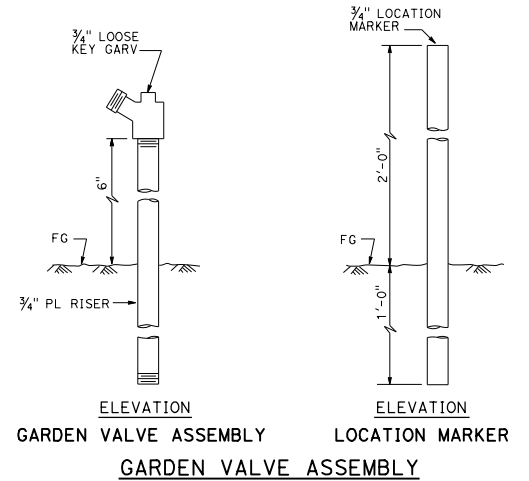

ELEVATION
GARDEN VALVE ASSEMBLY
ELEVATION
LOCATION MARKER

STATE OF CALIFORNIA
DEPARTMENT OF TRANSPORTATION
LANDSCAPE DETAILS

NO SCALE
RSP H6 DATED JULY 21, 2017 SUPERSEDES STANDARD PLAN H6 DATED
OCTOBER 30, 2015 - PAGE 235 OF THE STANDARD PLANS BOOK DATED 2015.

REVISED STANDARD PLAN RSP H6

2015 REVISED STANDARD PLAN RSP H6

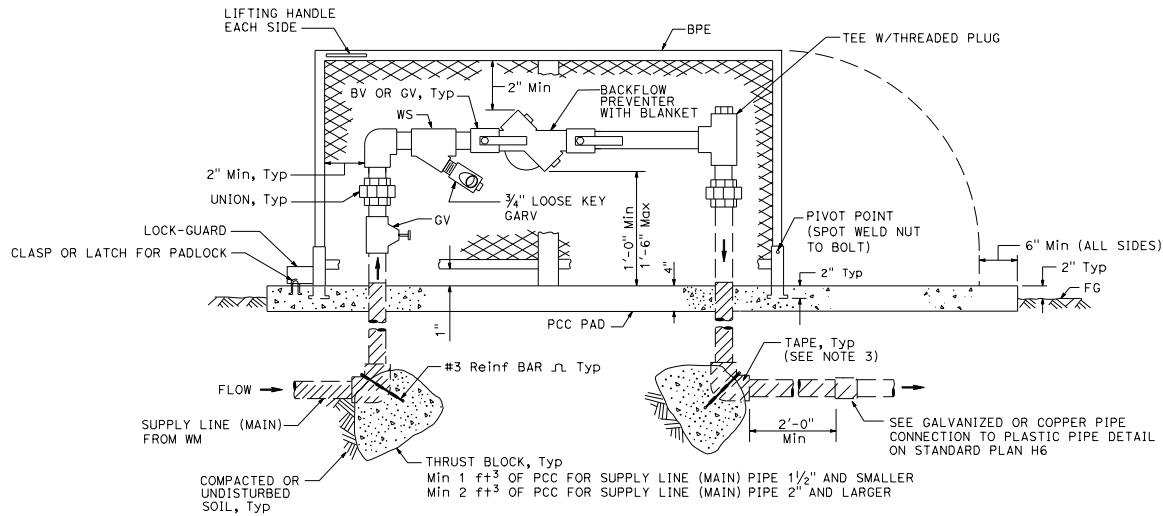

ELEVATION
BACKFLOW PREVENTER ASSEMBLY
IN ONE PIECE ENCLOSURE

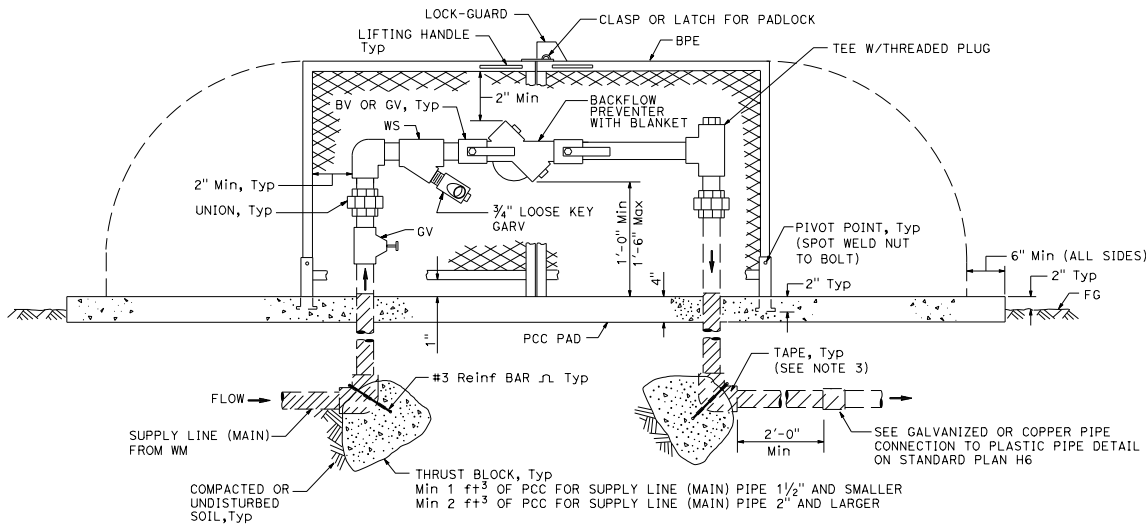

ELEVATION
BACKFLOW PREVENTER ASSEMBLY
IN TWO PIECE ENCLOSURE

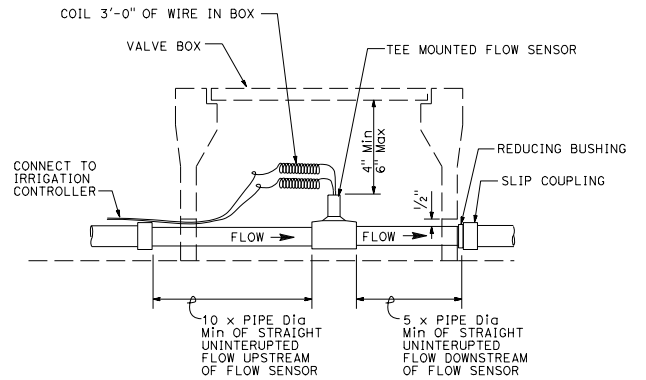

SECTION
FLOW SENSOR

STATE OF CALIFORNIA
DEPARTMENT OF TRANSPORTATION
LANDSCAPE DETAILS
NO SCALE

RSP H7 DATED JULY 21, 2017 SUPERSEDES STANDARD PLAN H7
DATED OCTOBER 30, 2015 - PAGE 236 OF THE STANDARD PLANS BOOK DATED 2015.
REVISED STANDARD PLAN RSP H7

DIST	COUNTY	ROUTE	POST MILES TOTAL PROJECT	SHEET NO.	TOTAL SHEETS

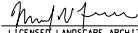
 LICENSED LANDSCAPE ARCHITECT
 July 21, 2017
 PLANS APPROVAL DATE
THE STATE OF CALIFORNIA OR ITS OFFICERS OR AGENTS SHALL NOT BE RESPONSIBLE FOR THE ACCURACY OR COMPLETENESS OF SCANNED COPIES OF THIS PLAN SHEET.

TO ACCOMPANY PLANS DATED _____

NOTES:

1. Wye strainer and fittings must be the same size as the backflow preventer shown on the plans.
2. Backflow preventer assembly manifold pipe must be the same pipe as the supply line (main) pipe to be installed from the water meter to the backflow preventer assembly.
3. All metal in contact with soil and Portland Cement Concrete must be wrapped with 2" wide plastic backed adhesive polyethylene tape 20 mil thick with 1/2" overlap.

2015 REVISED STANDARD PLAN RSP H7

DIST	COUNTY	ROUTE	POST MILES TOTAL PROJECT	SHEET TOTAL SHEETS

Michael J. Ferrero
 LICENSED LANDSCAPE ARCHITECT
 July 21, 2017
 PLANS APPROVAL DATE
THE STATE OF CALIFORNIA OR ITS OFFICERS OR AGENTS SHALL NOT BE RESPONSIBLE FOR THE ACCURACY OR COMPLETENESS OF SCANNED COPIES OF THIS PLAN SHEET.

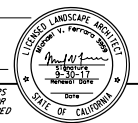

NOTES:

- 40" - 50"
- 12" downstream of RCV
18" upstream of RCV

TO ACCOMPANY PLANS DATED _____

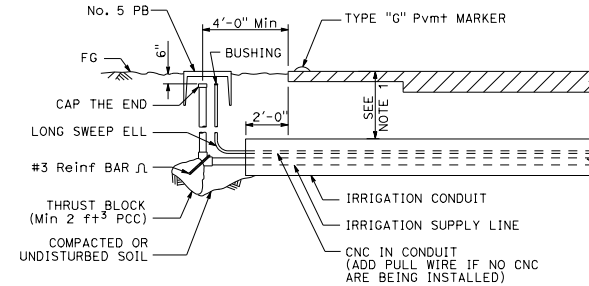

SECTION
IRRIGATION CONDUIT
UNDER TRAVELED WAY

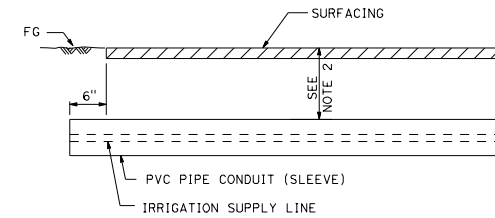

SECTION
PVC PIPE CONDUIT (SLEEVE)
UNDER SIDEWALKS, DRIVEWAYS PAVEMENT, SLOPE PAVING, PAVED DITCHES AND PATHS

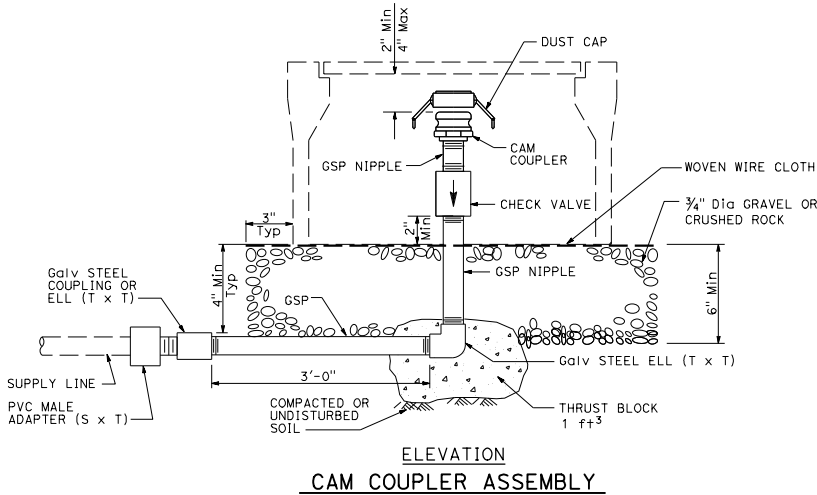

ELEVATION
CAM COUPLER ASSEMBLY

STATE OF CALIFORNIA
DEPARTMENT OF TRANSPORTATION
LANDSCAPE DETAILS
NO SCALE

RSP H8 DATED JULY 21, 2017 SUPERSEDES RSP H8 DATED APRIL 15, 2016 AND STANDARD PLAN H8 DATED OCTOBER 30, 2015 - PAGE 237 OF THE STANDARD PLANS BOOK DATED 2015.

REVISED STANDARD PLAN RSP H8

2015 REVISED STANDARD PLAN RSP H8

DIST	COUNTY	ROUTE	POST MILES TOTAL PROJECT	SHEET TOTAL SHEETS

Michael J. Ferrero
 LICENSED LANDSCAPE ARCHITECT
 PLANS APPROVAL DATE
 July 21, 2017
THE STATE OF CALIFORNIA OR ITS OFFICERS OR AGENTS SHALL NOT BE RESPONSIBLE FOR THE ACCURACY OR COMPLETENESS OF SCANNED COPIES OF THIS PLAN SHEET.



TO ACCOMPANY PLANS DATED _____

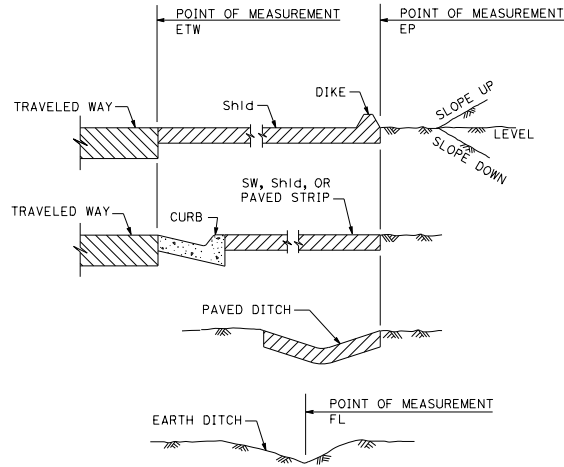

**SECTION
POINTS OF MEASUREMENT**

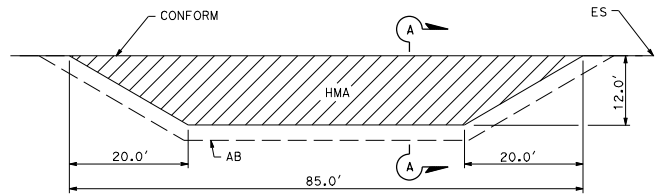

PLAN

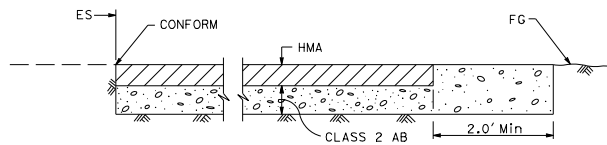

**SECTION A-A
MAINTENANCE VEHICLE PULLOUT**

NOTES:

1. 12" downstream of RCV
18" upstream of RCV
2. Width sufficient to allow snaking of pipe and CNC bundles without stacking.
3. 1 ft minimum to back of sidewalk.
4. 2" Min or Dia of largest pipe in trench.

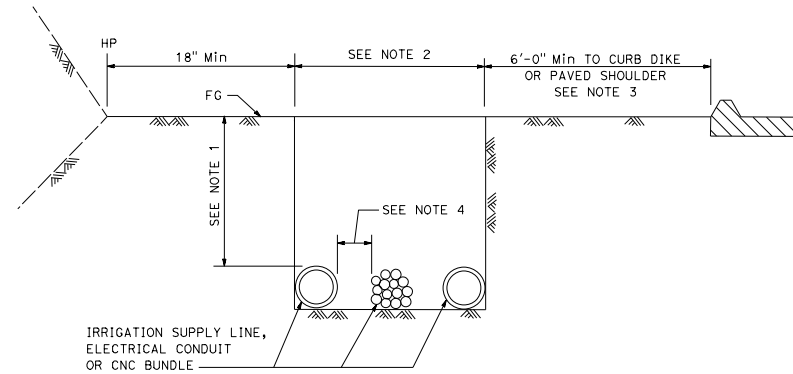

**SECTION
IRRIGATION TRENCH DETAIL**

STATE OF CALIFORNIA
DEPARTMENT OF TRANSPORTATION
LANDSCAPE DETAILS
NO SCALE

RSP H9 DATED JULY 21, 2017 SUPERSEDES STANDARD PLAN H9
DATED OCTOBER 30, 2015 - PAGE 238 OF THE STANDARD PLANS BOOK DATED 2015.
REVISED STANDARD PLAN RSP H9

2015 REVISED STANDARD PLAN RSP H9

DIST	COUNTY	ROUTE	POST MILES TOTAL PROJECT	SHEET TOTAL NO. SHEETS

LICENSED LANDSCAPE ARCHITECT
 July 21, 2017
 PLANS APPROVAL DATE
THE STATE OF CALIFORNIA OR ITS OFFICERS OR AGENTS SHALL NOT BE RESPONSIBLE FOR THE ACCURACY OR COMPLETENESS OF SCANNED COPIES OF THIS PLAN SHEET.

TO ACCOMPANY PLANS DATED _____

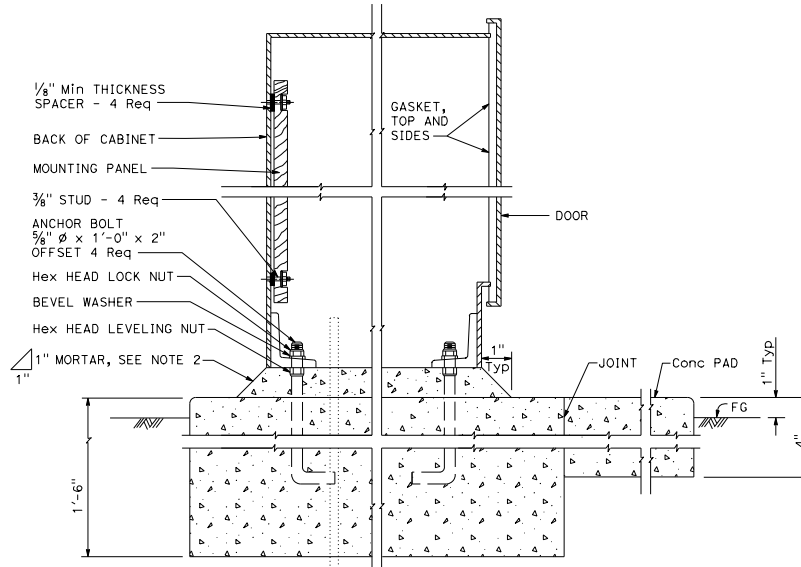
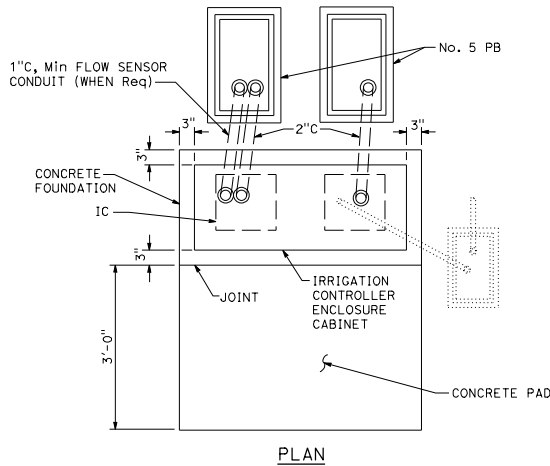

NOTES:

1. All dimensions are nominal.
2. Mortar shall be 1-part cement, 2-parts plaster sand.
3. Rain sensor unit and remote control valve actuator connectors to be provided when specified.
4. See project plans for location and number of irrigation controllers for each cabinet. Install the cabinet with the back facing the direction of oncoming traffic in the nearest traffic lane.
5. The electrical items shown in dropout are not labeled. See Standard Plan ES-3H for electrical requirements.

CABINET SECTION

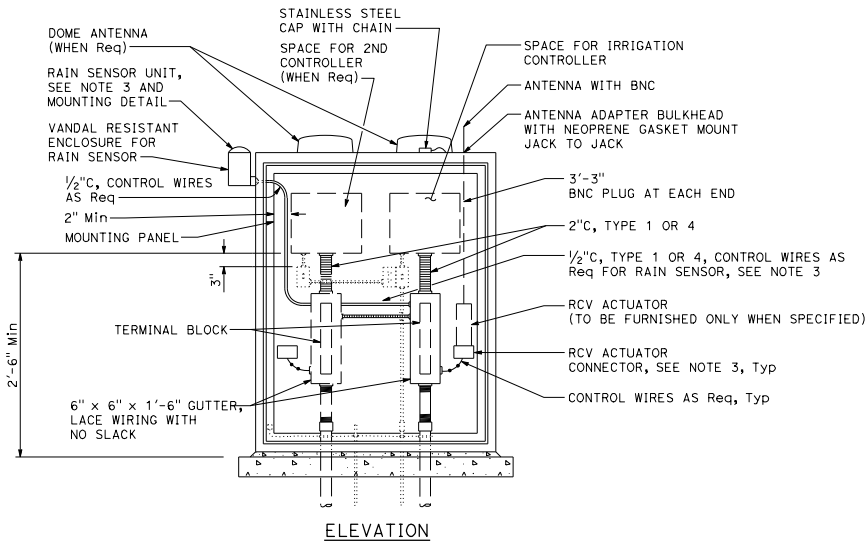

ELEVATION

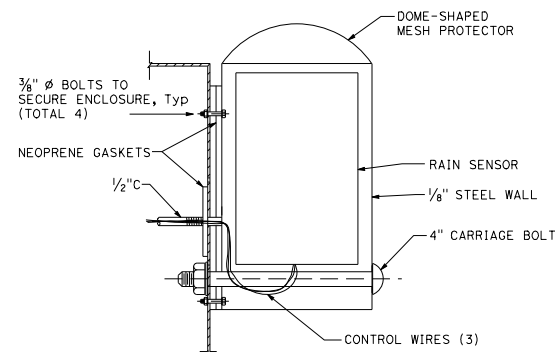

RAIN SENSOR UNIT

STATE OF CALIFORNIA
DEPARTMENT OF TRANSPORTATION
**IRRIGATION CONTROLLER
ENCLOSURE CABINET**

NO SCALE

RSP H10 DATED JULY 21, 2017 SUPERSEDES RSP H10 DATED JULY 15, 2016 AND STANDARD PLAN H10 DATED OCTOBER 30, 2015 - PAGE 239 OF THE STANDARD PLANS BOOK DATED 2015.

REVISED STANDARD PLAN RSP H10

2015 REVISED STANDARD PLAN RSP H10

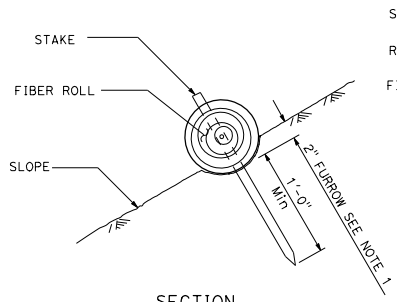

SECTION
FIBER ROLL (TYPE 1)

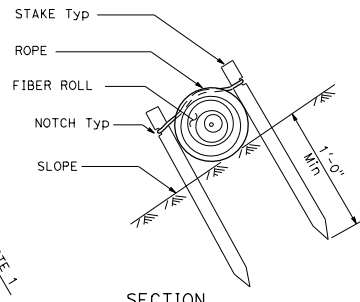

SECTION
FIBER ROLL (TYPE 2)

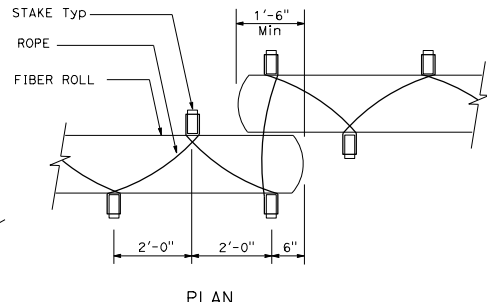

PLAN

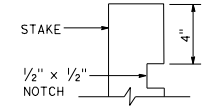

ELEVATION
STAKE NOTCH DETAIL

DIST	COUNTY	ROUTE	POST MILES TOTAL PROJECT	SHEET TOTAL SHEETS

 LICENSED LANDSCAPE ARCHITECT
 July 21, 2017
 PLANS APPROVAL DATE
 THE STATE OF CALIFORNIA OR ITS OFFICERS OR AGENTS SHALL NOT BE RESPONSIBLE FOR THE ACCURACY OR COMPLETENESS OF SCANNED COPIES OF THIS PLAN SHEET.

NOTE:
1. Installations shown in the perspectives are for slope inclination of 10:1 (Horiz:Vert) and steeper.

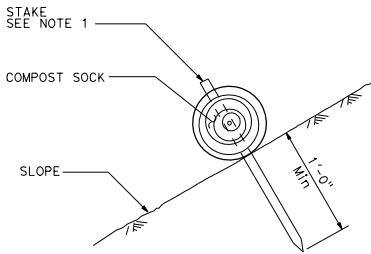

SECTION
COMPOST SOCK

NOTE:
1. May install stake adjacent to bottom edge of compost sock.

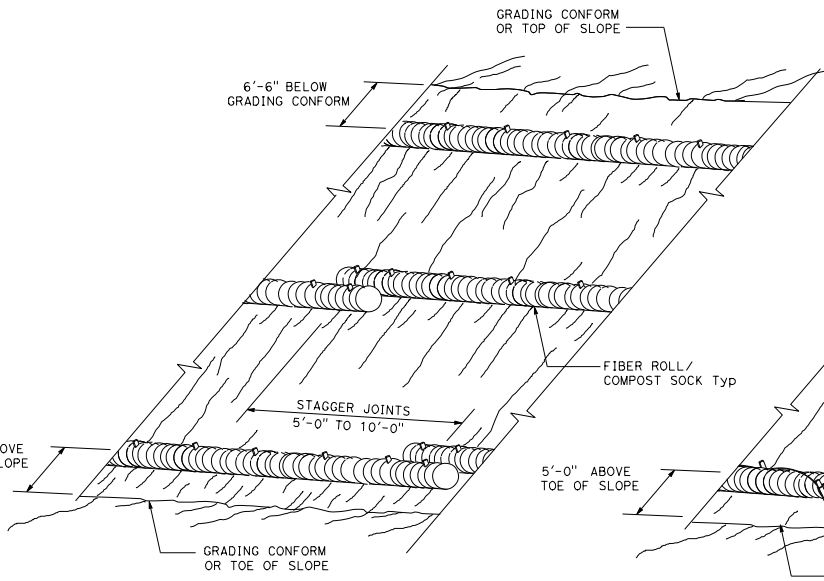

PERSPECTIVE
FIBER ROLL (TYPE 1)
COMPOST SOCK

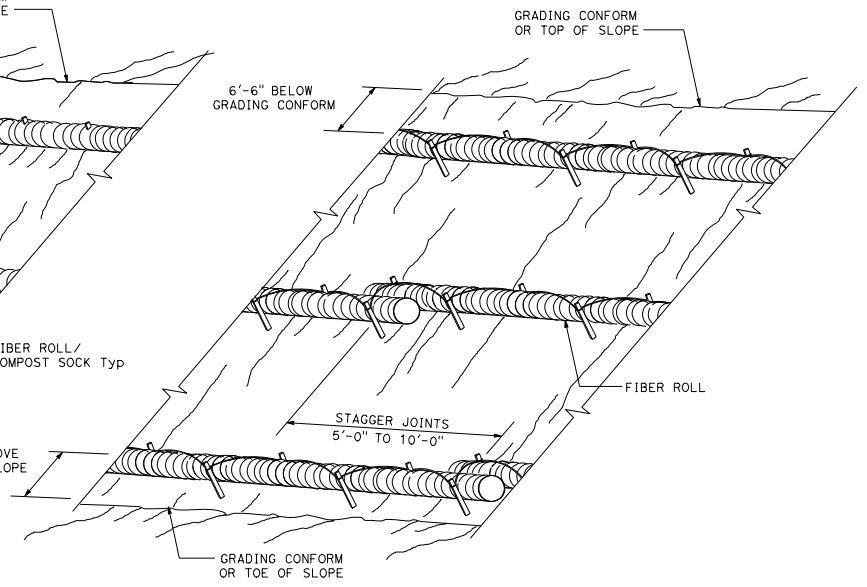

PERSPECTIVE
FIBER ROLL (TYPE 2)

STATE OF CALIFORNIA
DEPARTMENT OF TRANSPORTATION
EROSION CONTROL DETAILS
FIBER ROLL AND COMPOST SOCK
NO SCALE

RSP H51 DATED JULY 21, 2017 SUPERSEDES STANDARD PLAN H51
DATED OCTOBER 30, 2015 - PAGE 240 OF THE STANDARD PLANS BOOK DATED 2015.
REVISED STANDARD PLAN RSP H51

2015 REVISED STANDARD PLAN RSP H51

DIST	COUNTY	ROUTE	POST MILES TOTAL PROJECT	SHEET TOTAL SHEETS

Flornor E. Bourlata
 REGISTERED CIVIL ENGINEER
 No. CS4859
 Exp. 6-30-18
 CIVIL
 STATE OF CALIFORNIA

January 20, 2017
 PLANS APPROVAL DATE
 THE STATE OF CALIFORNIA OR ITS OFFICERS OR AGENTS SHALL NOT BE RESPONSIBLE FOR THE ACCURACY OR COMPLETENESS OF SCANNED COPIES OF THIS PLAN SHEET.

TO ACCOMPANY PLANS DATED _____

2015 REVISED STANDARD PLAN RSP P4

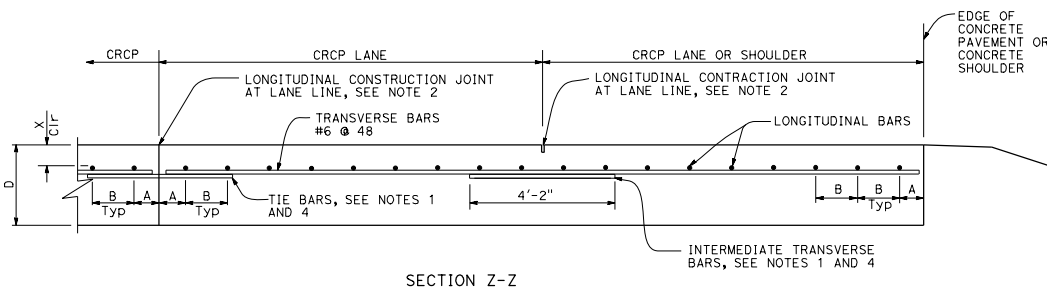
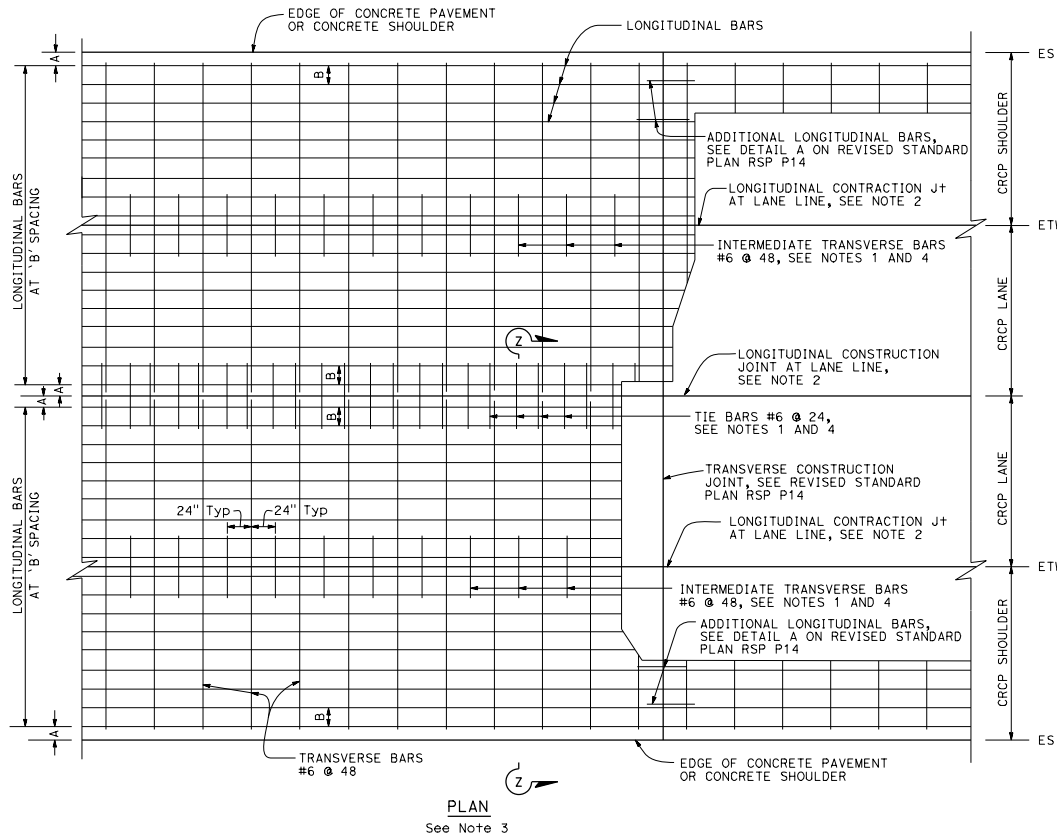

SLAB THICKNESS AND BAR SIZE		FIRST SPACING AT EDGE OR JOINT	REGULAR BARS	ADDITIONAL BARS AT TRANSVERSE CONSTRUCTION JOINT	Clr
D	BAR SIZE	SPACING A	SPACING B	SPACING 2 x B	X
.75'	#6	3" TO 4"	8.0"	16"	4"
.80'	#6	3" TO 4"	7.5"	15"	4"
.85'	#6	3" TO 4"	7.0"	14"	4"
.90'	#6	3" TO 4"	6.5"	13"	4"
.95'	#6	3" TO 4"	6.25"	12.5"	4"
1.00'	#6	3" TO 4"	6.0"	12"	5"
1.05'	#6	3" TO 4"	5.75"	11.5"	5"
1.10'	#6	3" TO 4"	5.5"	11"	5.5"

NOTES:

1. Place tie bars and intermediate transverse bars parallel to and in the same plane as transverse bars.
2. For longitudinal contraction and construction joint details, see Revised Standard Plan RSP P16.
3. For curved lane layout see Revised Standard Plan RSP P16.
4. For tie bar and intermediate transverse bar details, see Revised Standard Plan RSP P16.

ABBREVIATION:

D = Thickness of CRCP

STATE OF CALIFORNIA
 DEPARTMENT OF TRANSPORTATION
**CONTINUOUSLY REINFORCED
 CONCRETE PAVEMENT**

NO SCALE

RSP P4 DATED JANUARY 20, 2017 SUPERSEDES STANDARD PLAN P4
DATED OCTOBER 30, 2015 - PAGE 135 OF THE STANDARD PLANS BOOK DATED 2015.

REVISED STANDARD PLAN RSP P4

DIST	COUNTY	ROUTE	POST MILES TOTAL PROJECT	SHEET NO.	TOTAL SHEETS

Flornor E. Baurista
 REGISTERED CIVIL ENGINEER
 No. CS4859
 Exp. 6-30-18
 CIVIL
 STATE OF CALIFORNIA

January 20, 2017
 PLANS APPROVAL DATE
 THE STATE OF CALIFORNIA OR ITS OFFICERS OR AGENTS SHALL NOT BE RESPONSIBLE FOR THE ACCURACY OR COMPLETENESS OF SCANNED COPIES OF THIS PLAN SHEET.

TO ACCOMPANY PLANS DATED _____

NOTES:

1. For longitudinal bar size, spacing and clearances, see Revised Standard Plan RSP P4.
2. For tie bar and intermediate transverse bar details, see Revised Standard Plan RSP P16.
3. Place intermediate transverse bars parallel to and in the same plane as transverse bars.
4. Construct transverse joints at right angle to the longitudinal joints in adjacent CRCP. Space joints at no less than 10' intervals and no more than 14' intervals. Match location of JPCP transverse joint with CRCP transverse construction joint, expansion joint or wide flange beam. Omit dowel bars.
5. For longitudinal contraction joint details, see Revised Standard Plan RSP P16.
6. For additional longitudinal bars detail, see Detail A on Revised Standard Plan RSP P14.
7. For longitudinal construction joint plan layout not shown, see Revised Standard Plan RSP P4. For tie bar details at longitudinal construction joint, see Revised Standard Plan RSP P16.
8. For limits of rumble strips, see Project Plans.

ABBREVIATION:

D = Thickness of CRCP

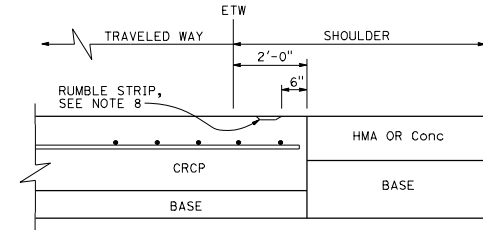

DETAIL A

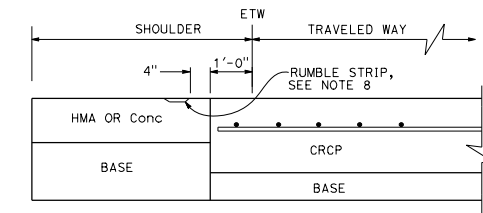

DETAIL B

STATE OF CALIFORNIA
DEPARTMENT OF TRANSPORTATION
**CONTINUOUSLY REINFORCED
CONCRETE PAVEMENT
(WIDENED LANE)**

NO SCALE

RSP P5A DATED JANUARY 20, 2017 SUPERSEDES STANDARD PLAN P5A
DATED OCTOBER 30, 2015 - PAGE 136 OF THE STANDARD PLANS BOOK DATED 2015.

REVISED STANDARD PLAN RSP P5A

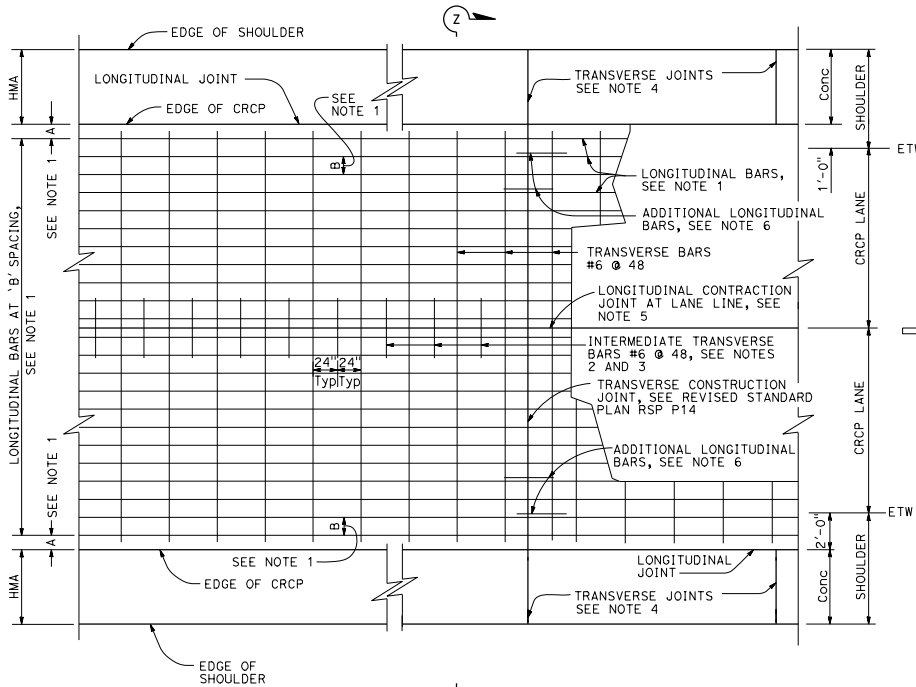

PLAN
See Note 7

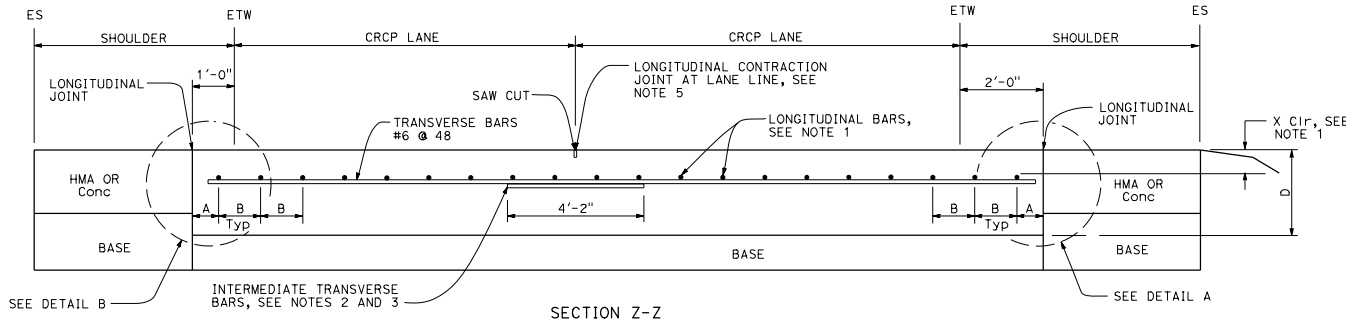

SECTION Z-Z

2015 REVISED STANDARD PLAN RSP P5A

Dist	COUNTY	ROUTE	POST MILES TOTAL PROJECT	SHEET NO.	TOTAL SHEETS

Flornor E. Bautista
 REGISTERED CIVIL ENGINEER
 No. CS4859
 Exp. 6-30-18
 CIVIL
 STATE OF CALIFORNIA

January 20, 2017
 PLANS APPROVAL DATE
 THE STATE OF CALIFORNIA OR ITS OFFICERS
 OR AGENTS SHALL NOT BE RESPONSIBLE FOR
 THE ACCURACY OR COMPLETENESS OF SCANNED
 COPIES OF THIS PLAN SHEET.

TO ACCOMPANY PLANS DATED _____

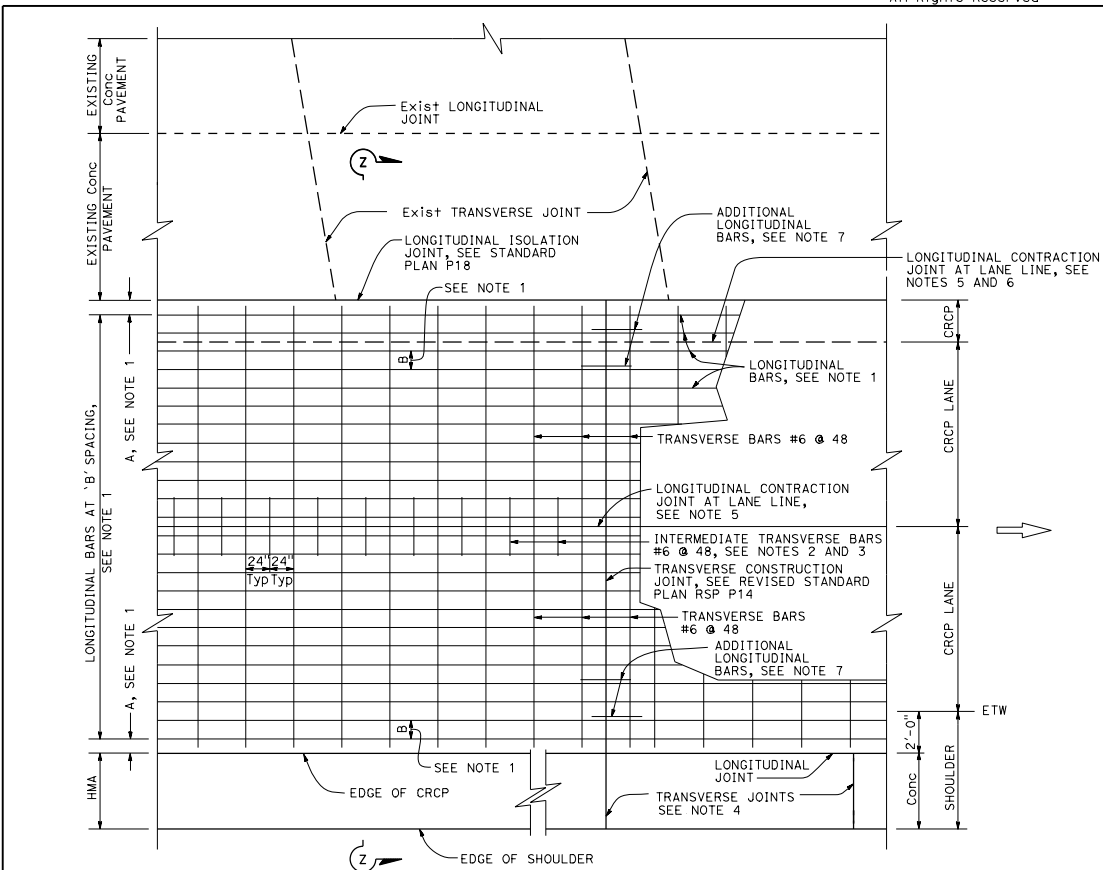

NOTES:

- For longitudinal bar size, spacing and clearances, see Revised Standard Plan RSP P4.
- For tie bar and intermediate transverse bar details, see Revised Standard Plan RSP P16.
- Place intermediate transverse bars parallel to and in the same plane as transverse bars.
- Construct transverse joints at right angle to the longitudinal joints in adjacent CRCP. Space joints at no less than 10' intervals and no more than 14' intervals. Match location of JPCP transverse joint with CRCP transverse construction joint, expansion joint or wide flange beam. Omit dowel bars.
- For longitudinal contraction joint details, see Revised Standard Plan RSP P16.
- Do not construct longitudinal contraction joint when edge of new CRCP is less than 3'-3" from lane line.
- For additional longitudinal bars detail, see Detail A on Revised Standard Plan RSP P14.
- For longitudinal construction joint plan layout not shown, see Revised Standard Plan RSP P4. For tie bar details at longitudinal construction joint, see Revised Standard Plan RSP P16.
- For limits of rumble strips, see Project Plans.

ABBREVIATION:

D = Thickness of CRCP

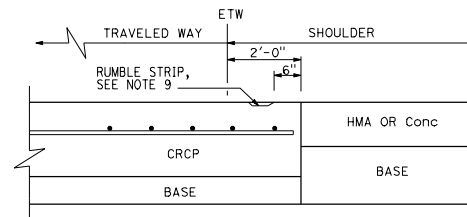

DETAIL A

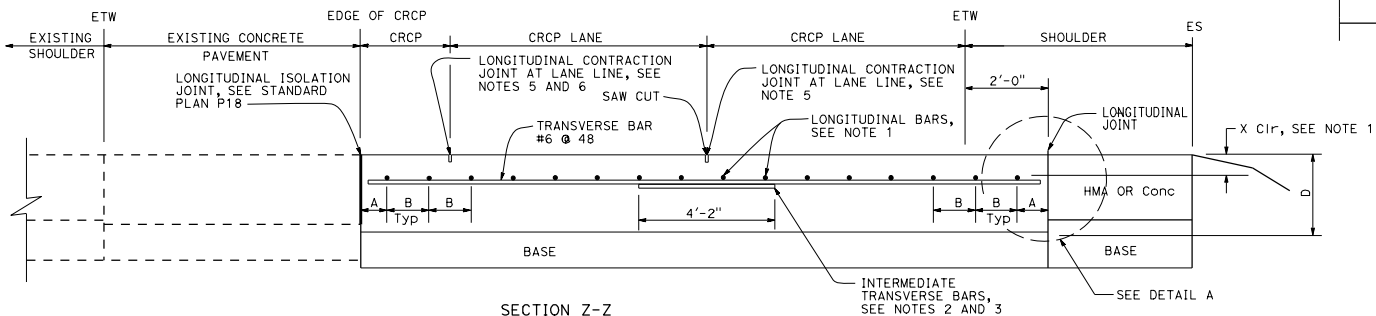

SECTION Z-Z

STATE OF CALIFORNIA
 DEPARTMENT OF TRANSPORTATION
**CONTINUOUSLY REINFORCED
 CONCRETE PAVEMENT
 (WIDENED LANE)
 LANE AND SHOULDER
 ADDITION OR REPLACEMENT**

NO SCALE

RSP P5B DATED JANUARY 20, 2017 SUPERSEDES STANDARD PLAN P5B
DATED OCTOBER 30, 2015 - PAGE 137 OF THE STANDARD PLANS BOOK DATED 2015.

REVISED STANDARD PLAN RSP P5B

2015 REVISED STANDARD PLAN RSP P5B

NOTES:

1. For longitudinal bar size, spacing and clearances, see Table 1 on Revised Standard Plan RSP P4.
2. For tie bars in longitudinal construction joint, see Revised Standard Plan RSP P16.
3. Place additional longitudinal bars parallel to and in the same plane as the longitudinal bars.
4. Place additional longitudinal bars symmetrically about longitudinal construction joint.

ABBREVIATION

D = Thickness of CRCP

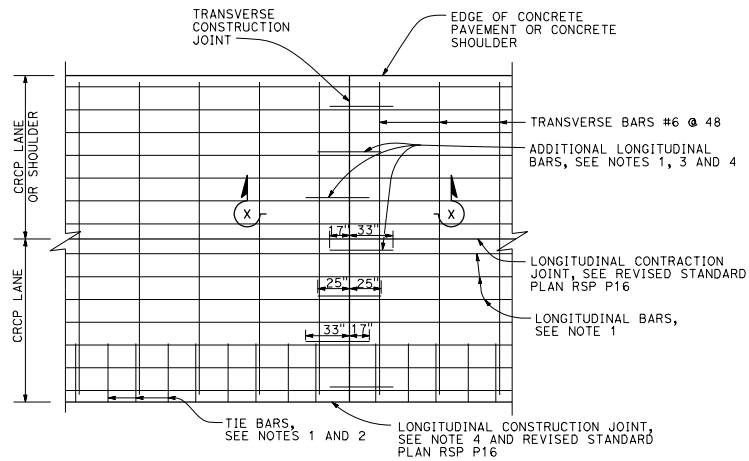

DETAIL A

Additional longitudinal bars at transverse construction joint

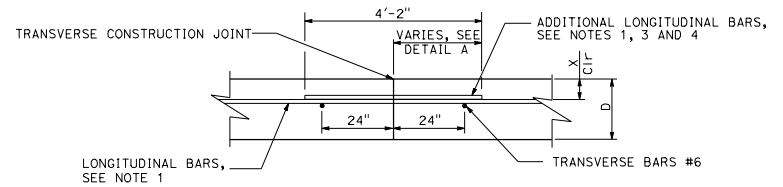

SECTION X-X

TRANSVERSE CONSTRUCTION JOINT

STATE OF CALIFORNIA
DEPARTMENT OF TRANSPORTATION
**CONTINUOUSLY REINFORCED
CONCRETE PAVEMENT
TRANSVERSE CONSTRUCTION JOINT**

NO SCALE

RSP P14 DATED JANUARY 20, 2017 SUPERSEDES STANDARD PLAN P14
DATED OCTOBER 30, 2015 - PAGE 144 OF THE STANDARD PLANS BOOK DATED 2015.

REVISED STANDARD PLAN RSP P14

DIST	COUNTY	ROUTE	POST MILES TOTAL PROJECT	SHEET NO.	TOTAL SHEETS

Florante E. Baulista
 REGISTERED CIVIL ENGINEER
 January 20, 2017
 PLANS APPROVAL DATE
 No. CS4859
 Exp. 6-30-18
 CIVIL
 STATE OF CALIFORNIA

THE STATE OF CALIFORNIA OR ITS OFFICERS OR AGENTS SHALL NOT BE RESPONSIBLE FOR THE ACCURACY OR COMPLETENESS OF SCANNED COPIES OF THIS PLAN SHEET.

TO ACCOMPANY PLANS DATED _____

2015 REVISED STANDARD PLAN RSP P14

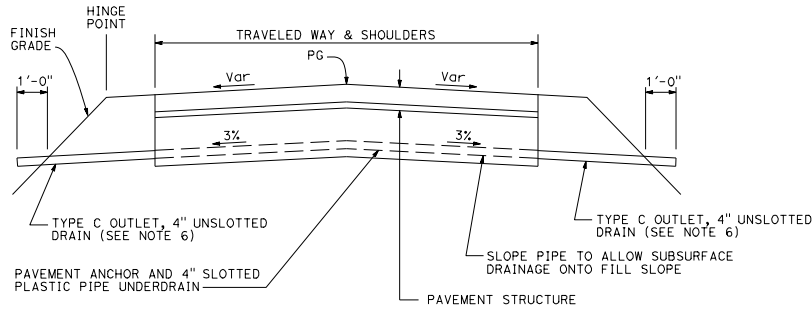

PAVEMENT ANCHOR PROFILE

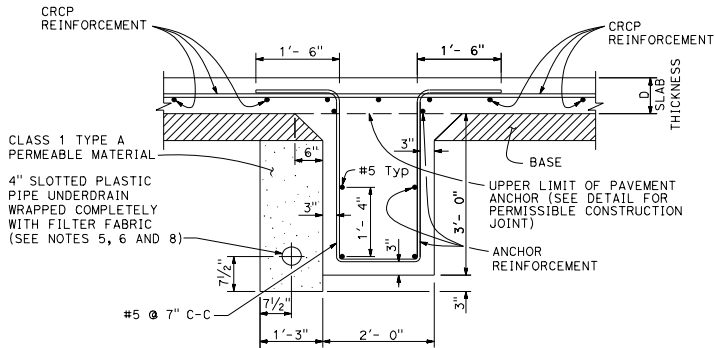

PAVEMENT ANCHOR

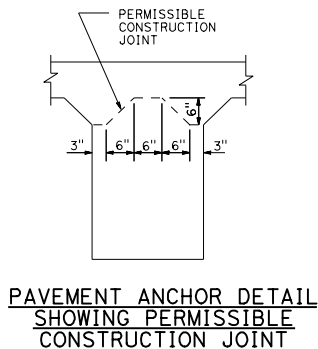

**PAVEMENT ANCHOR DETAIL
SHOWING PERMISSIBLE
CONSTRUCTION JOINT**

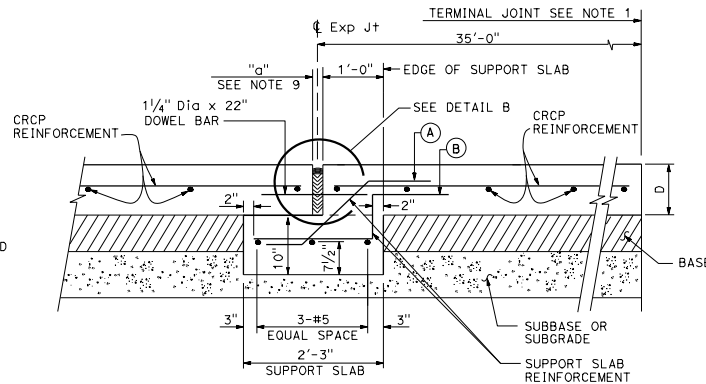

EXPANSION JOINT TYPE AN

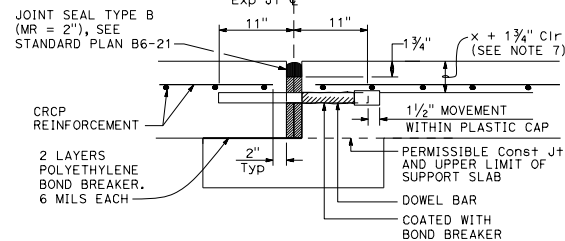

DETAIL B

(For layout, tolerances, and other details not shown, see Standard Plan P10.)

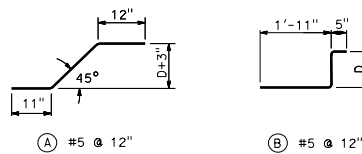

REINFORCEMENT DETAIL

DIST	COUNTY	ROUTE	POST MILES TOTAL PROJECT	SHEET NO.	TOTAL SHEETS

Flornor E. Baurista
 REGISTERED CIVIL ENGINEER
 No. CS4859
 Exp. 6-30-18
 CIVIL
 STATE OF CALIFORNIA

January 20, 2017
 PLANS APPROVAL DATE
 THE STATE OF CALIFORNIA OR ITS OFFICERS OR AGENTS SHALL NOT BE RESPONSIBLE FOR THE ACCURACY OR COMPLETENESS OF SCANNED COPIES OF THIS PLAN SHEET.

TO ACCOMPANY PLANS DATED _____

NOTES:

1. For the locations of the terminal joints, expansion joints and pavement anchors, see project plans.
2. The CRCP shall continue across the pavement anchor and expansion joints as shown.
3. Details of reinforcement, tie bars, and longitudinal joints (and if necessary, transverse construction joints) are shown on Revised Standard Plans RSP P4 and RSP P16.
4. Transverse construction joints are not allowed within 20'-0" of the pavement anchor.
5. When placing pipe through concrete barrier, use 4" unslotted plastic pipe wrapped completely with 3/8" polystyrene.
6. See Standard Plan P51 for details not shown.
7. See Revised Standard Plans RSP P4 for "x".
8. Place the 4" Slotted Plastic Pipe on the high side of the longitudinal grade.
9. See Standard Plan B6-21 for "a".

ABBREVIATION:

D = Thickness of CRCP

STATE OF CALIFORNIA
DEPARTMENT OF TRANSPORTATION
**CONTINUOUSLY REINFORCED
CONCRETE PAVEMENT -
EXPANSION JOINT AND ANCHOR DETAILS**

NO SCALE

RSP P31B DATED JANUARY 20, 2017 SUPERSEDES STANDARD PLAN P31B
DATED OCTOBER 30, 2015 - PAGE 152 OF THE STANDARD PLANS BOOK DATED 2015.

REVISED STANDARD PLAN RSP P31B

2015 REVISED STANDARD PLAN RSP P31B

DIST	COUNTY	ROUTE	POST MILES TOTAL PROJECT	SHEET TOTAL SHEETS

Flornate E. Baulista
 REGISTERED CIVIL ENGINEER
 No. CS4859
 Exp. 6-30-18
 CIVIL
 STATE OF CALIFORNIA

January 20, 2017
 PLANS APPROVAL DATE
 THE STATE OF CALIFORNIA OR ITS OFFICERS OR AGENTS SHALL NOT BE RESPONSIBLE FOR THE ACCURACY OR COMPLETENESS OF SCANNED COPIES OF THIS PLAN SHEET.

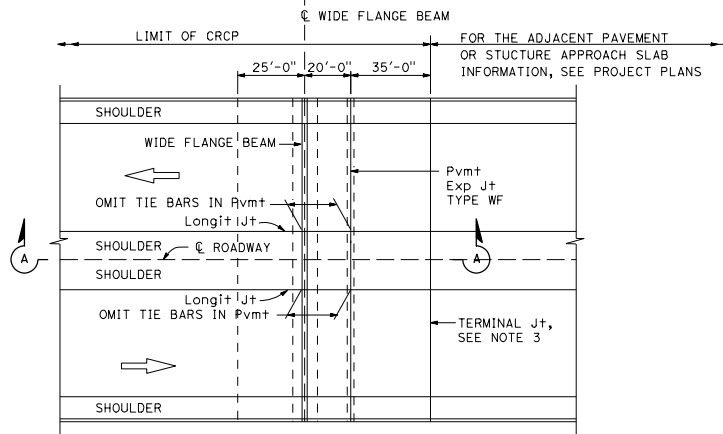

PLAN

NOTES:

- For additional details on reinforcement member quantities of the wide flange beam terminal and Pavement Expansion Joint Type WF, see Standard Plan P32B.
- For reinforcement (A), (B), and (C) Details, see Standard Plan P32B.
- For the Pavement Terminal Joint Details, see Standard Plan P31A. For Pavement Terminal Joint Type, see Project Plans.
- See Revised Standard Plan RSP P4 for "x".
- D = Thickness of CRCP
- See Standard Plan B6-21 for "a".

TO ACCOMPANY PLANS DATED _____

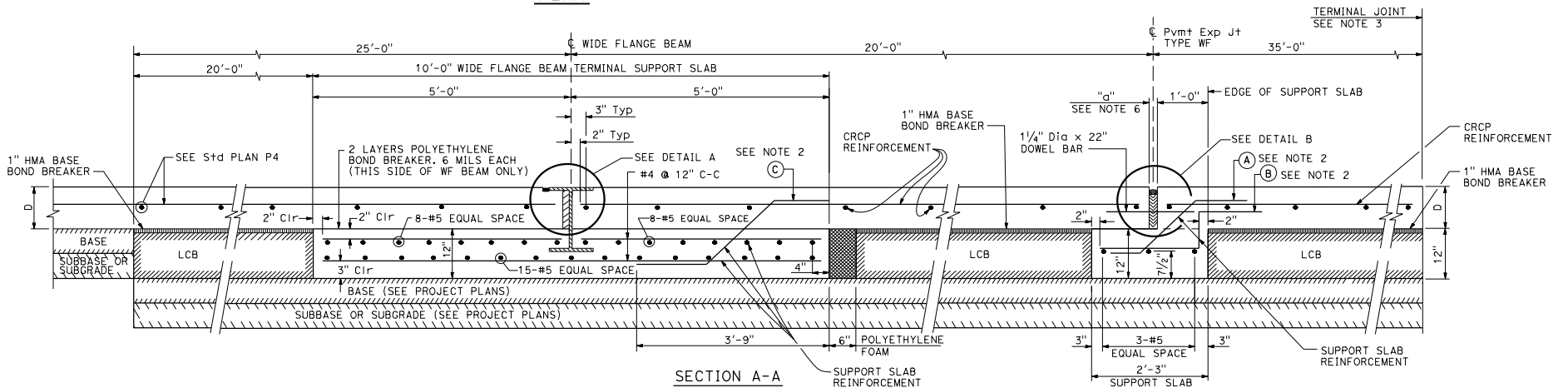

SECTION A-A

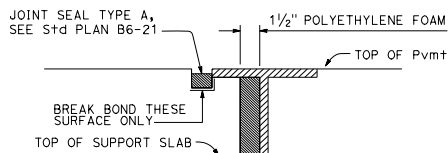

DETAIL A

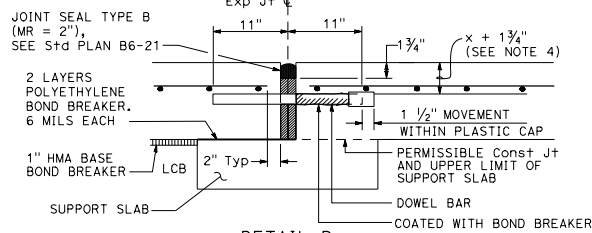

DETAIL B

For layout, tolerances, and other details not shown see Std Plan P10.

STATE OF CALIFORNIA
 DEPARTMENT OF TRANSPORTATION
**CONTINUOUSLY REINFORCED
 CONCRETE PAVEMENT -
 WIDE FLANGE BEAM TERMINALS**

NO SCALE

RSP P32A DATED JANUARY 20, 2017 SUPERSEDES STANDARD PLAN P32A
 DATED OCTOBER 30, 2015 - PAGE 153 OF THE STANDARD PLANS BOOK DATED 2015.

REVISED STANDARD PLAN RSP P32A

2015 REVISED STANDARD PLAN RSP P32A

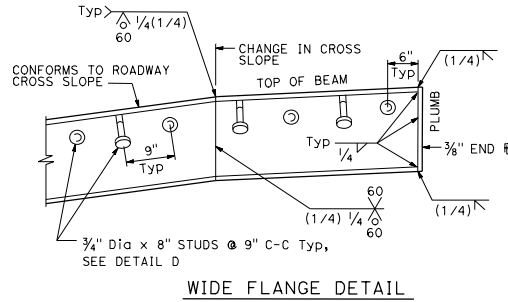

WIDE FLANGE DETAIL

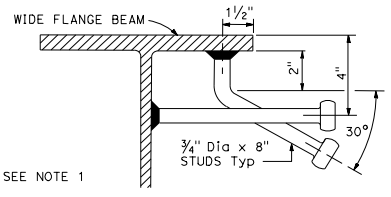

DETAIL D

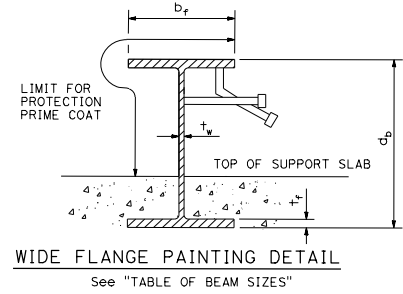

WIDE FLANGE PAINTING DETAIL

See "TABLE OF BEAM SIZES"

DIST	COUNTY	ROUTE	POST MILES TOTAL PROJECT	SHEET TOTAL SHEETS

Florante E. Bautista
 REGISTERED CIVIL ENGINEER
 No. CS4859
 Exp. 6-30-18
 CIVIL
 STATE OF CALIFORNIA

July 21, 2017
 PLANS APPROVAL DATE
 THE STATE OF CALIFORNIA OR ITS OFFICERS OR AGENTS SHALL NOT BE RESPONSIBLE FOR THE ACCURACY OR COMPLETENESS OF SCANNED COPIES OF THIS PLAN SHEET.

TO ACCOMPANY PLANS DATED _____

LEGEND:

- b_f - FLANGE WIDTH
- t_f - FLANGE THICKNESS
- t_w - WEB THICKNESS
- d_b - BEAM DEPTH
- D1 - PAVEMENT THICKNESSES
- D2 - PAVEMENT THICKNESSES

NOTES:

1. Weld 3/8" plate to each end of wide flange beam at pavement edges only. End plate covers the entire wide flange beam.
2. Extend polyethylene foam to the sides and edges of the front part of the plate.

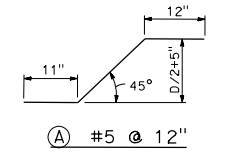

(A) #5 @ 12"

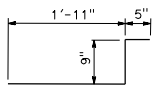

(B) #5 @ 12"

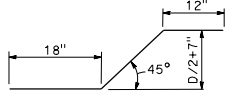

(C) #4 @ 12"

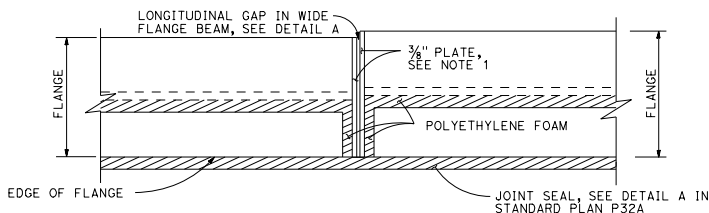

PLAN

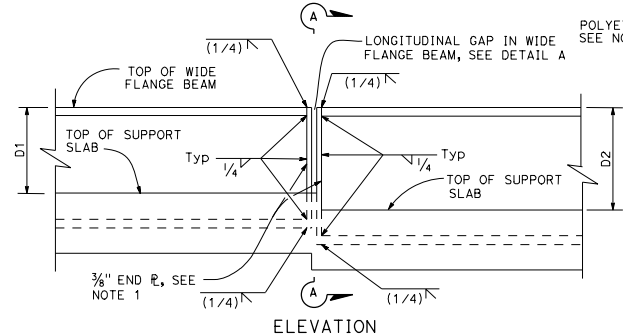

ELEVATION

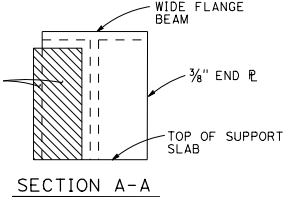

SECTION A-A

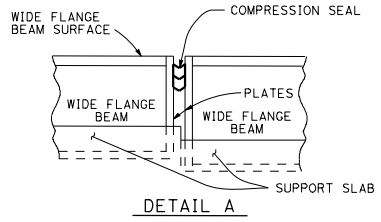

DETAIL A

TABLE OF BEAM SIZES					
PAVEMENT THICKNESS	WIDE FLANGE BEAM DESIGNATION	d _b	b _f	t _f	t _w
.75'	W14 x 43	13.70"	8.00"	0.53"	0.31"
.80'	W14 x 68	14.04"	10.04"	0.72"	0.42"
.85'	W16 x 89	16.75"	10.37"	0.88"	0.53"
.90'	W16 x 89	16.75"	10.37"	0.88"	0.53"
.95'	W18 x 97	18.59"	11.15"	0.87"	0.54"
1.00'	W18 x 97	18.59"	11.15"	0.87"	0.54"
1.05'	W18 x 97	18.59"	11.15"	0.87"	0.54"
1.10'	W18 x 97	18.59"	11.15"	0.87"	0.54"

CONCRETE AND STEEL QUANTITIES								
ITEM	PAVEMENT THICKNESS							
	.75'	.80'	.85'	.90'	.95'	1.00'	1.05'	1.10'
WIDE FLANGE BEAM								
CONCRETE	4.8 CY	4.8 CY	4.8 CY	4.8 CY	4.8 CY	4.8 CY	4.8 CY	4.8 CY
TERMINAL SLAB								
REINFORCING STEEL	552.0 LBS	552.2 LBS	552.4 LBS	552.6 LBS	552.8 LBS	553.0 LBS	553.1 LBS	553.3 LBS
Exp JOINT TYPE								
CONCRETE	1.1 CY	1.1 CY	1.1 CY	1.1 CY	1.1 CY	1.1 CY	1.1 CY	1.1 CY
WIDE FLANGE								
REINFORCING STEEL	99.9 LBS	99.9 LBS	100.2 LBS	100.5 LBS	100.8 LBS	101.1 LBS	101.1 LBS	101.6 LBS
SUPPORT SLAB								
STEEL BEAM (WEIGHT OF WIDE FLANGE BEAM AND STUDS)	43.0 LBS/LF +2 PLATES @ 14.9 LBS EA	69.51 LBS/LF +2 PLATES @ 14.9 LBS EA	90.51 LBS/LF +2 PLATES @ 18.5 LBS EA	90.51 LBS/LF +2 PLATES @ 18.5 LBS EA	98.51 LBS/LF +2 PLATES @ 22.0 LBS EA	98.51 LBS/LF +2 PLATES @ 22.0 LBS EA	98.51 LBS/LF +2 PLATES @ 22.0 LBS EA	98.51 LBS/LF +2 PLATES @ 22.0 LBS EA

STATE OF CALIFORNIA
 DEPARTMENT OF TRANSPORTATION
**CONTINUOUSLY REINFORCED
 CONCRETE PAVEMENT
 WIDE FLANGE BEAM TERMINALS**
 NO SCALE

RSP P32B DATED JULY 21, 2017 SUPERSEDES STANDARD PLAN P32B
 DATED OCTOBER 30, 2015 - PAGE 154 OF THE STANDARD PLANS BOOK DATED 2015.
REVISED STANDARD PLAN RSP P32B

2015 REVISED STANDARD PLAN RSP P32B

DIST	COUNTY	ROUTE	POST MILES TOTAL PROJECT	SHEET TOTAL SHEETS
REGISTERED CIVIL ENGINEER July 21, 2017 PLANS APPROVAL DATE THE STATE OF CALIFORNIA OR ITS OFFICERS OR AGENTS SHALL NOT BE RESPONSIBLE FOR THE ACCURACY OR COMPLETENESS OF SCANNED COPIES OF THIS PLAN SHEET.				

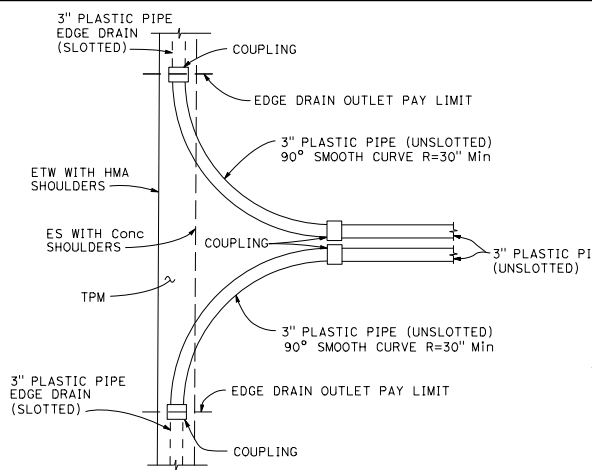

PLAN
DUAL OUTLET AND/OR VENT
See Note 2

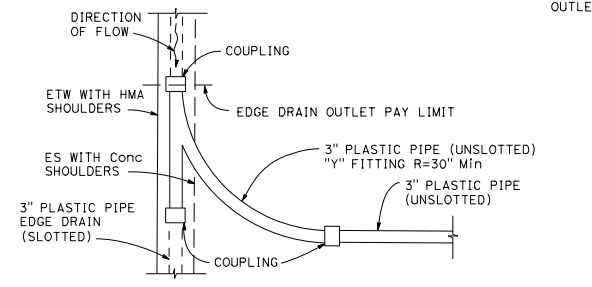

PLAN
INTERMEDIATE OUTLET
See Note 2

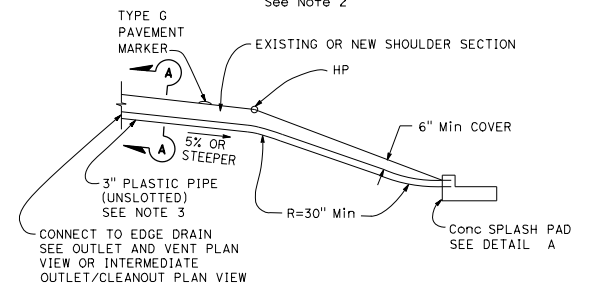

ELEVATION
TYPE A OUTLET

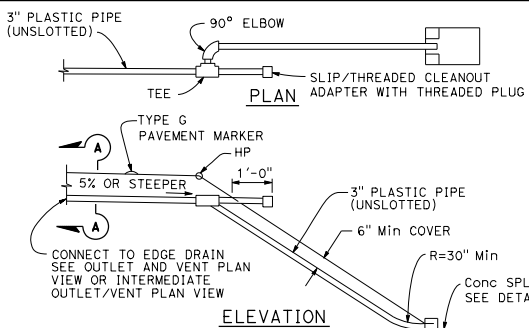

ELEVATION
TYPE B OUTLET

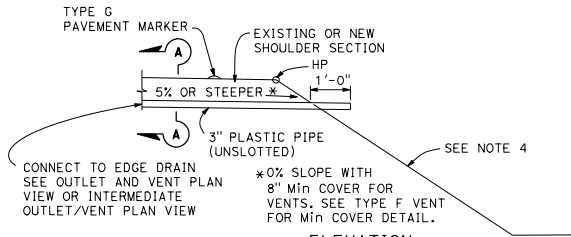

ELEVATION
TYPE C OUTLET AND/OR VENT

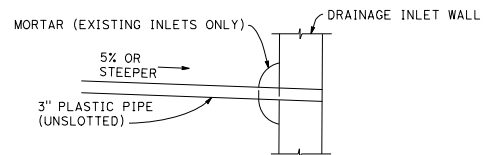

ELEVATION
TYPE D OUTLET CONNECTION TO DRAINAGE INLET

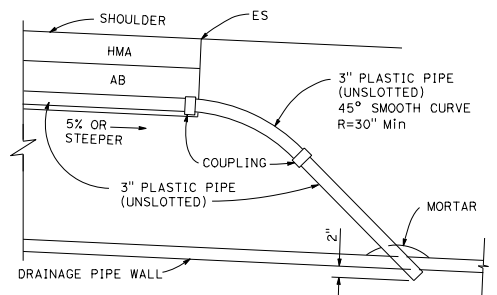

ELEVATION
TYPE E OUTLET CONNECTION TO DRAINAGE PIPE

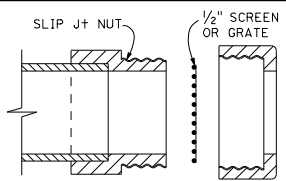

EDGE DRAIN OUTLET AND VENT COVER

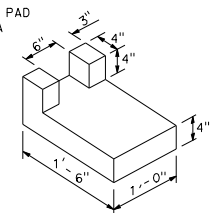

DETAIL A
CONCRETE SPLASH PAD

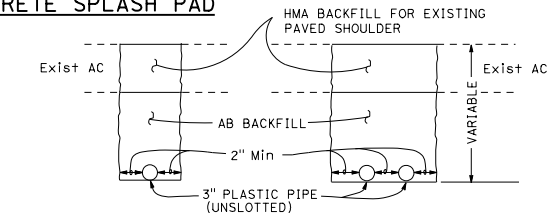

SECTION A-A
OUTLET EXCAVATION AND BACKFILL IN PAVED SHOULDERS
See Note 5

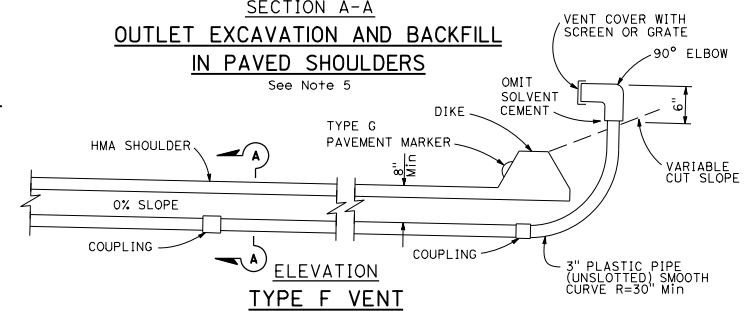

ELEVATION
TYPE F VENT

STATE OF CALIFORNIA
DEPARTMENT OF TRANSPORTATION
EDGE DRAIN OUTLET AND VENT DETAILS
NO SCALE

RSP P51 DATED JULY 21, 2017 SUPERSEDES STANDARD PLAN P51
DATED OCTOBER 30, 2015 - PAGE 161 OF THE STANDARD PLANS BOOK DATED 2015.

REVISED STANDARD PLAN RSP P51

2015 REVISED STANDARD PLAN RSP P51

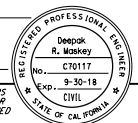
DIST	COUNTY	ROUTE	POST MILES TOTAL PROJECT	SHEET TOTAL SHEETS
				
REGISTERED CIVIL ENGINEER July 21, 2017 PLANS APPROVAL DATE THE STATE OF CALIFORNIA OR ITS OFFICERS OR AGENTS SHALL NOT BE RESPONSIBLE FOR THE ACCURACY OR COMPLETENESS OF SCANNED COPIES OF THIS PLAN SHEET.				

TO ACCOMPANY PLANS DATED _____
PIPE PLUG OR VENT COVER
SEE NOTE 4

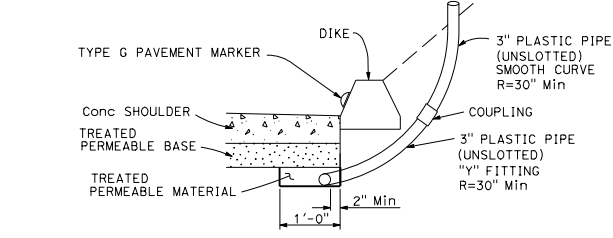
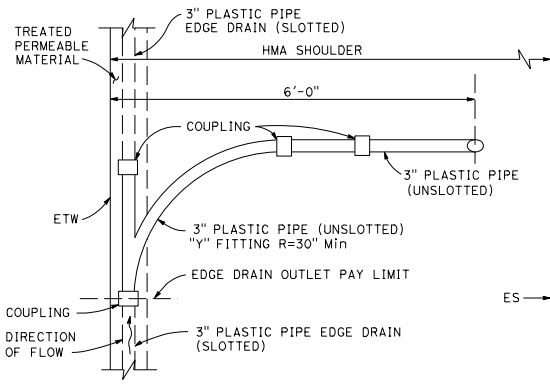
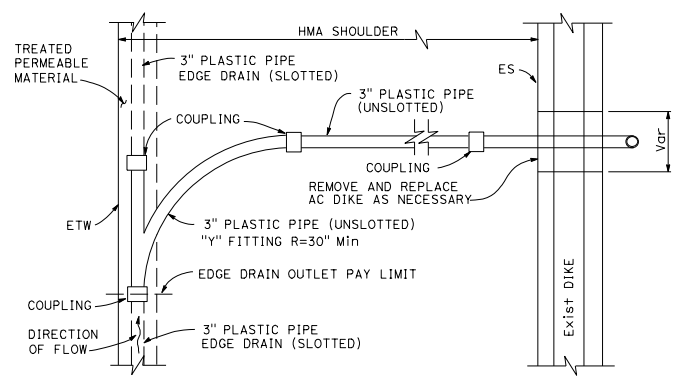
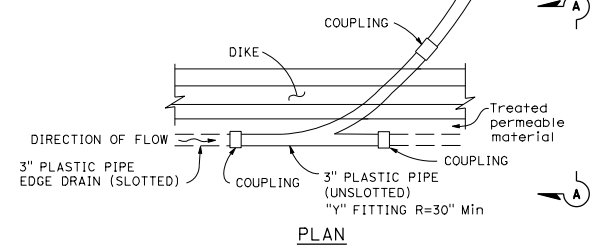
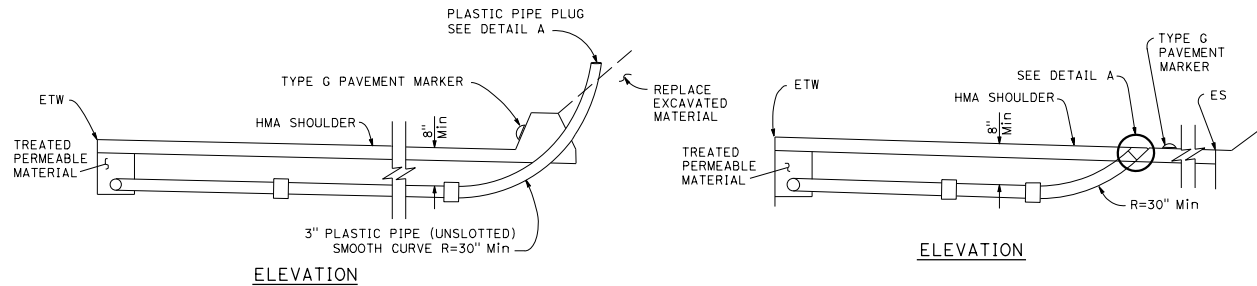

PLAN
TYPE 1 CLEANOUT
See Note 2

PLAN
TYPE 2 CLEANOUT
See Note 2

SECTION A-A
TYPE 3 CLEANOUT/TYPE G VENT
See Note 4

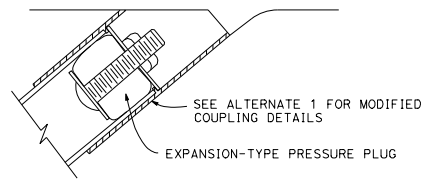
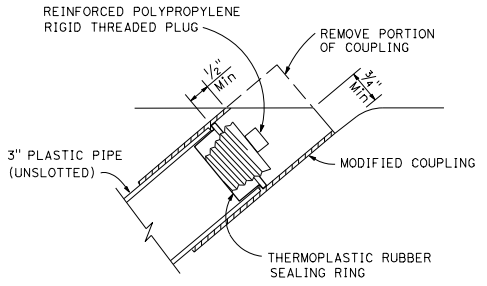

DETAIL A
PLASTIC PIPE PLUG
See Note 3

ALTERNATIVE 1

ALTERNATIVE 2

NOTES:

1. See project plans for location and type of cleanout or vent installations.
2. The position of slotted plastic pipe and limits of treated permeable material shown are for the Type 1 structural section drainage system shown on Standard Plan P50.
3. Other types of plugs may be substituted with the Engineer's approval.
4. The Type 3 cleanout and Type G vent is for use with concrete shoulders. The Type 6 structural section drainage system from Standard Plan P50 is shown. Use plastic pipe plug shown in Detail A with Type 3 cleanouts. Use vent cover shown on Revised Standard Plan RSP P51 with Type G vents.

STATE OF CALIFORNIA
DEPARTMENT OF TRANSPORTATION
**EDGE DRAIN CLEANOUT
AND VENT DETAILS**
NO SCALE

RSP P52 DATED JULY 21, 2017 SUPERSEDES STANDARD PLAN P52
DATED OCTOBER 30, 2015 - PAGE 162 OF THE STANDARD PLANS BOOK DATED 2015.
REVISED STANDARD PLAN RSP P52

2015 REVISED STANDARD PLAN RSP P52

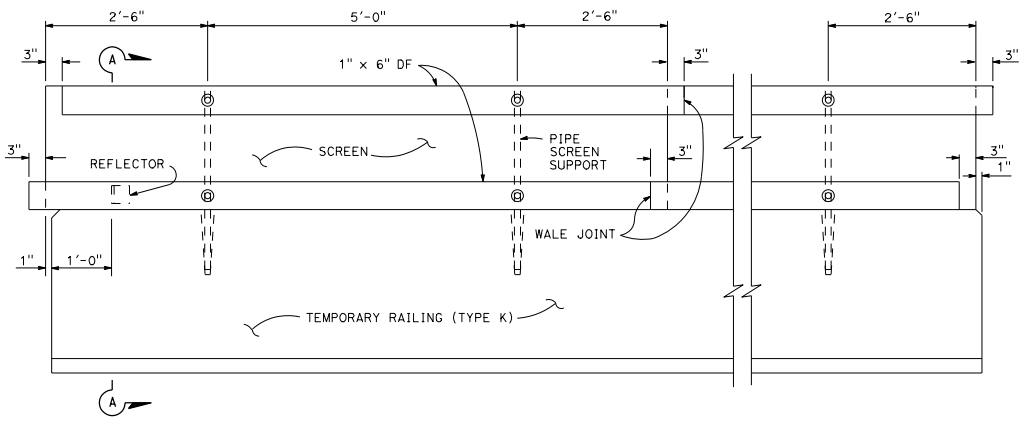

ELEVATION

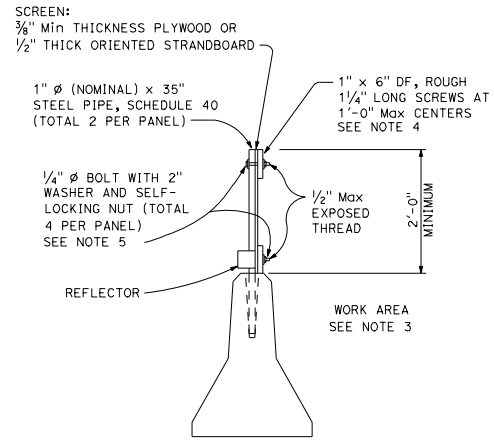

SECTION A-A

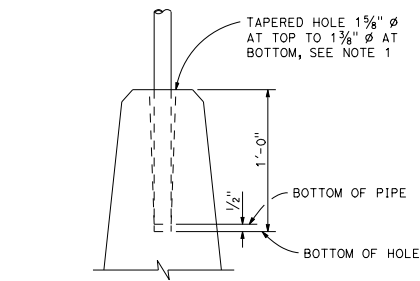

SCREEN ANCHORAGE DETAIL

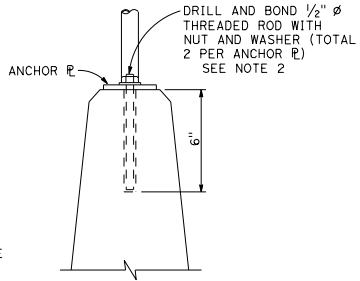

**SCREEN ANCHORAGE DETAIL
ALTERNATIVE "A"**

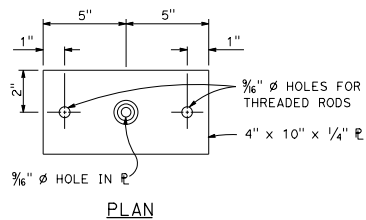

**ANCHOR PLATE DETAIL
ALTERNATIVE "A"**

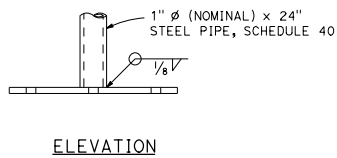

ELEVATION

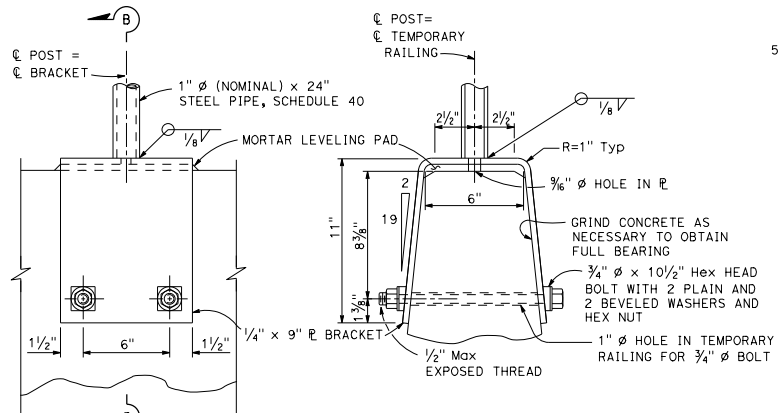

**SCREEN ANCHORAGE DETAIL
ALTERNATIVE "B"**

SECTION B-B

DIST	COUNTY	ROUTE	POST MILES TOTAL PROJECT	SHEET TOTAL NO. SHEETS

Randell D. Hiatt
 REGISTERED CIVIL ENGINEER
 No. CS0200
 Exp. 6-30-17
 CIVIL
 STATE OF CALIFORNIA

January 20, 2017
 PLANS APPROVAL DATE
 THE STATE OF CALIFORNIA OR ITS OFFICERS
 OR AGENTS SHALL NOT BE RESPONSIBLE FOR
 THE ACCURACY OR COMPLETENESS OF SCANNED
 COPIES OF THIS PLAN SHEET.

TO ACCOMPANY PLANS DATED _____

NOTES:

1. Straight holes $1\frac{1}{2}$ " ϕ of the depth shown may be used in lieu of the tapered holes.
2. Resin capsule-type anchorage devices may be substituted for threaded rods.
3. Place screen on work area side of the temporary railing where traffic will only be on one side of the temporary railing.
4. Clinched 8d box nails may be substituted for screws. The nails shall be clinched on the work area side of the screen where traffic will only be on one side of the temporary railing.
5. U-bolts may be substituted for $\frac{1}{4}$ " ϕ bolts.

STATE OF CALIFORNIA
DEPARTMENT OF TRANSPORTATION

TEMPORARY TRAFFIC SCREEN
NO SCALE

RSP T4 DATED JANUARY 20, 2017 SUPERSEDES STANDARD PLAN T4 DATED OCTOBER 30, 2015 - PAGE 247 OF THE STANDARD PLANS BOOK DATED 2015.

REVISED STANDARD PLAN RSP T4

DIST	COUNTY	ROUTE	POST MILES TOTAL PROJECT	SHEET NO.	TOTAL SHEETS

Devinder Singh
REGISTERED CIVIL ENGINEER

January 20, 2017
PLANS APPROVAL DATE

THE STATE OF CALIFORNIA OR ITS OFFICERS
OR AGENTS SHALL NOT BE RESPONSIBLE FOR
THE ACCURACY OR COMPLETENESS OF SCANNED
COPIES OF THIS PLAN SHEET.

REGISTERED PROFESSIONAL ENGINEER
Devinder Singh
No. CS0470
Exp. 6-30-17
CIVIL
STATE OF CALIFORNIA

TO ACCOMPANY PLANS DATED _____

TABLE 1

SPEED (S)	MINIMUM TAPER LENGTH * FOR WIDTH OF OFFSET 12 FEET (W)				MAXIMUM CHANNELIZING DEVICE SPACING		
	TANGENT 2L	MERGING L	SHIFTING L/2	SHOULDER L/3	X	Y	Z **
					TAPER	TANGENT	CONFLICT
mph	ft	ft	ft	ft	ft	ft	ft
20	160	80	40	27	20	40	10
25	250	125	63	42	25	50	12
30	360	180	90	60	30	60	15
35	490	245	123	82	35	70	17
40	640	320	160	107	40	80	20
45	1080	540	270	180	45	90	22
50	1200	600	300	200	50	100	25
55	1320	660	330	220	50	100	25
60	1440	720	360	240	50	100	25
65	1560	780	390	260	50	100	25
70	1680	840	420	280	50	100	25
75	1800	900	450	300	50	100	25

* - For other offsets, use the following merging taper length formula for L:
For speed of 40 mph or less, $L = WS^2/60$
For speed of 45 mph or more, $L = WS$

Where: L = Taper length in feet

W = Width of offset in feet

S = Posted speed limit, off-peak 85th-percentile
speed prior to work starting, or the anticipated
operating speed in mph

** - Use for taper and tangent sections where there are no pavement markings or where
there is a conflict between existing pavement markings and channelizers (CA).

TABLE 2

SPEED *	Min D **	DOWNGRADE Min D ***		
		-3%	-6%	-9%
		ft	ft	ft
mph	ft	ft	ft	ft
20	115	116	120	126
25	155	158	165	173
30	200	205	215	227
35	250	257	271	287
40	305	315	333	354
45	360	378	400	427
50	425	446	474	507
55	495	520	553	593
60	570	598	638	686
65	645	682	728	785
70	730	771	825	891
75	820	866	927	1003

* - Speed is posted speed limit, off-peak 85th-percentile
speed prior to work starting, or the anticipated
operating speed in mph

** - Longitudinal buffer space or flagger station spacing

*** - Use on sustained downgrade steeper than -3 percent
and longer than 1 mile.

TABLE 3

ROAD TYPE	DISTANCE BETWEEN SIGNS *		
	A	B	C
	ft	ft	ft
URBAN - 25 mph OR LESS	100	100	100
URBAN - MORE THAN 25 mph TO 40 mph	250	250	250
URBAN - MORE THAN 40 mph	350	350	350
RURAL	500	500	500
EXPRESSWAY / FREEWAY	1000	1500	2640

* - The distances are approximate, are intended for guidance
purposes only, and should be applied with engineering judgment.
These distances should be adjusted by the Engineer for field
conditions, if necessary, by increasing or decreasing the
recommended distances.

STATE OF CALIFORNIA
DEPARTMENT OF TRANSPORTATION

**TRAFFIC CONTROL SYSTEM TABLES
FOR LANE AND RAMP CLOSURES**

NO SCALE

RSP T9 DATED JANUARY 20, 2017 SUPERSEDES STANDARD PLAN T9
DATED OCTOBER 30, 2015 - PAGE 249 OF THE STANDARD PLANS BOOK DATED 2015.

REVISED STANDARD PLAN RSP T9

2015 REVISED STANDARD PLAN RSP T9

NOTES:

Use Revised Standard Plan RSP T9 for tables.
Use cone spacing X for taper segment, Y for tangent segment or Z for conflict situations, as appropriate, per Table 1, unless X, Y, or Z cone spacing is shown on this sheet.
Provide at least one person to continuously maintain traffic control devices for lane closures.

DIST	COUNTY	ROUTE	POST MILES TOTAL PROJECT	SHEET NO.	TOTAL SHEETS

 REGISTERED CIVIL ENGINEER
 No. C68559
 Exp. 9-30-19
 STATE OF CALIFORNIA

April 20, 2018
 PLANS APPROVAL DATE
 THE STATE OF CALIFORNIA OR ITS OFFICERS OR AGENTS SHALL NOT BE RESPONSIBLE FOR THE ACCURACY OR COMPLETENESS OF SCANNED COPIES OF THIS PLAN SHEET.

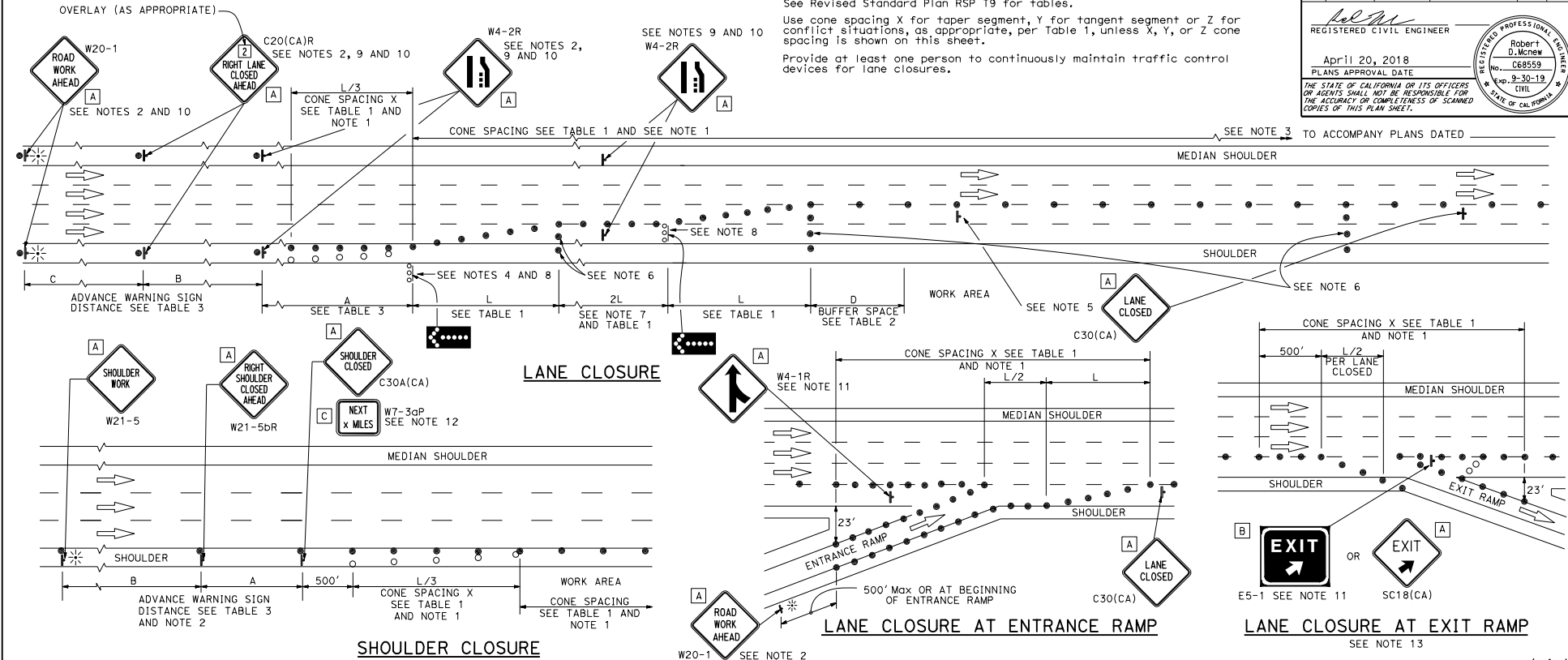



NOTES:

- Portable delineators placed at one-half the spacing indicated for traffic cones may be used instead of cones for daytime closures only.
- Each advance warning sign shall be equipped with at least two flags for daytime closure. Each flag shall be at least 16" x 16" in size and shall be orange or fluorescent red-orange in color. Flashing beacons shall be placed at the locations indicated for lane closure during hours of darkness.
- A G20-2 "END ROAD WORK" sign, with minimum size of 48" x 24" as appropriate, shall be placed at the end of the lane closure unless the end of work area is obvious or ends within the larger project's limits.
- A minimum 1500' sight distance shall be provided where possible for vehicles approaching the first flashing arrow sign. Lane closures shall not begin at the top of crest vertical curve or on a horizontal curve.
- Place a C30(CA) sign every 1000' throughout length of lane closure.
- A minimum of 3 cones shall be placed transversely across each closed lane and shoulder at each location where a taper across a traffic lane ends and every 1000' as shown on the "Lane Closure" detail. Two type II barricades may be used instead of the 3 cones. The transverse alignment of the cones or barricades on the closed shoulder may be shifted from the transverse alignment to provide access to the work.
- The 2L tangent shown along lane lines shall be used between the L tapers required for each closed traffic lane.
- Use one flashing arrow sign for each lane closed. The flashing arrow sign shall be type I.
- Median lane closures shall conform to the details as shown except that C20(CA)L and W4-2L signs shall be used.

- Duplicate sign installations are not required:
 - On opposite shoulder if at least one-half of the available lanes remain open to traffic.
 - In the median if the width of the median shoulder is less than 8' and the outside lanes are to be closed.
- The E5-1 or SC18(CA) and W4-1 signs shall be used as shown.
- A W7-3aP "NEXT _____ MILES" plaque must be used if the shoulder closure extends beyond the distance that can be perceived by road users.
- For the warning sign requirements at the Exit Ramp, when work is proposed on the local street, see CA MUTCD Figure 6H-22 to 6H-27.

LEGEND

- TRAFFIC CONE
- TRAFFIC CONE (OPTIONAL TAPER)
- ⊥ TEMPORARY TRAFFIC CONTROL SIGN
-  FLASHING ARROW SIGN (FAS)
-  FAS SUPPORT OR TRAILER
-  PORTABLE FLASHING BEACON

SIGN PANEL SIZE (Min)

- A** 48" x 48"
- B** 72" x 60"
- C** 36" x 30"

STATE OF CALIFORNIA
DEPARTMENT OF TRANSPORTATION
**TRAFFIC CONTROL SYSTEM
FOR LANE CLOSURE ON
FREEWAYS AND EXPRESSWAYS**
NO SCALE

RSP T10 DATED APRIL 20, 2018 SUPERSEDES RSP T10 DATED JANUARY 20, 2017 AND STANDARD PLAN T10 DATED OCTOBER 30, 2015 - PAGE 250 OF THE STANDARD PLANS BOOK DATED 2015.

REVISED STANDARD PLAN RSP T10

2015 REVISED STANDARD PLAN RSP T10

NOTES:

See Revised Standard Plan RSP T9 for tables.
Use cone spacing X for taper segment, Y for tangent segment or Z for conflict situations, as appropriate, per Table 1, unless X, Y, or Z cone spacing is shown on this sheet.
Provide at least one person to continuously maintain traffic control devices for lane closures.

DIST	COUNTY	ROUTE	POST MILES TOTAL PROJECT	SHEET NO.	TOTAL SHEETS

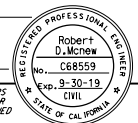
 REGISTERED CIVIL ENGINEER
 April 20, 2018
 PLANS APPROVAL DATE
 THE STATE OF CALIFORNIA OR ITS OFFICERS OR AGENTS SHALL NOT BE RESPONSIBLE FOR THE ACCURACY OR COMPLETENESS OF SCANNED COPIES OF THIS PLAN SHEET.

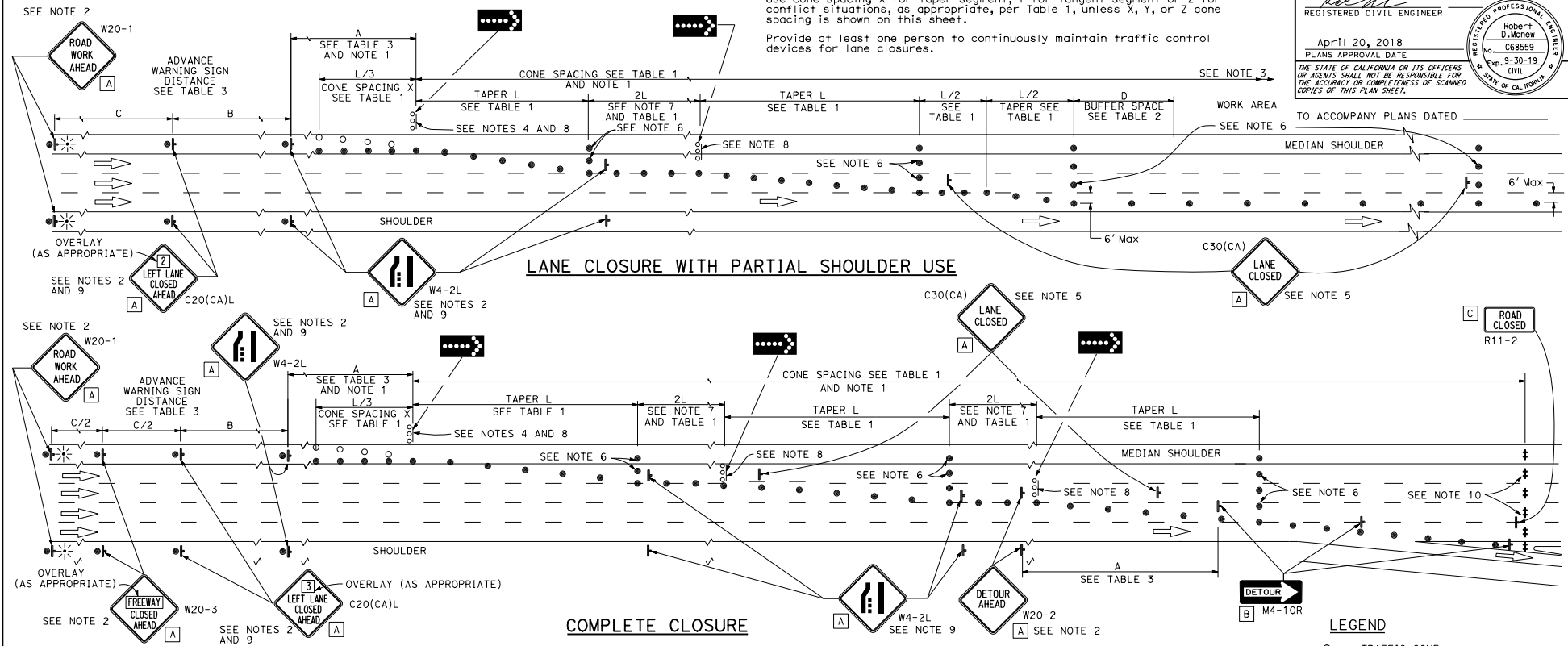

LANE CLOSURE WITH PARTIAL SHOULDER USE

COMPLETE CLOSURE



NOTES:

- Portable delineators placed at one-half the spacing indicated for traffic cones may be used instead of cones for daytime closures only.
- Each advance warning sign shall be equipped with at least two flags for daytime closure. Each flag shall be at least 16" x 16" in size and shall be orange or fluorescent red-orange in color. Flashing beacons shall be placed at the locations indicated for lane closure during hours of darkness.
- A G20-2 "END ROAD WORK" sign, with minimum size of 48" x 24" as appropriate, shall be placed at the end of the lane closure unless the end of work area is obvious or ends within a larger project's limits.
- A minimum 1500' of sight distance shall be provided where possible for vehicles approaching the first flashing arrow sign. Lane closures shall not begin at the top of crest vertical curve or on a horizontal curve.
- Place a C30(CA) sign every 1000' throughout length of lane closure.
- A minimum of 3 cones shall be placed transversely across each closed lane and shoulder at each location where a taper, across a traffic lane ends and every 1000' as shown on the "Lane Closure with Partial Shoulder Use" detail. Two type II barricades may be used instead of the 3 cones. The transverse alignment of the cones or barricades on the closed shoulder may be shifted from the transverse alignment to provide access to the work.
- The 2L tangent shown along lane lines shall be used between the L tapers required for each closed traffic lane.
- Use one flashing arrow sign for each lane closed. The flashing arrow sign shall be Type I.
- Lane closures on the right side using partial median shoulder as a traffic lane shall conform to the details shown except that C20(CA)R and W4-2R signs shall be used.
- A minimum of Two Type II or III barricades shall be placed across each closed lane and shoulder at the location shown and every 2000' within the complete closure area. Within the complete closure area, the transverse alignment of the barricades on the closed shoulder may be shifted from the transverse alignment to provide access to the work.

SIGN PANEL SIZE (Min)

- A 48" x 48"
- B 48" x 18"
- C 48" x 30"

LEGEND

- TRAFFIC CONE
- TRAFFIC CONE (OPTIONAL TAPER)
- ⊥ TEMPORARY TRAFFIC CONTROL SIGN
-  FLASHING ARROW SIGN (FAS)
-  FAS SUPPORT OR TRAILER
-  PORTABLE FLASHING BEACON

STATE OF CALIFORNIA
DEPARTMENT OF TRANSPORTATION
**TRAFFIC CONTROL SYSTEM
FOR LANE CLOSURE ON
FREEWAYS AND EXPRESSWAYS**
NO SCALE

RSP T10A DATED APRIL 20, 2018 SUPERSEDES STANDARD PLAN T10A
DATED OCTOBER 30, 2015 - PAGE 251 OF THE STANDARD PLANS BOOK DATED 2015.

REVISED STANDARD PLAN RSP T10A

2015 REVISED STANDARD PLAN RSP T10A

DIST	COUNTY	ROUTE	POST MILES TOTAL PROJECT	SHEET NO.	TOTAL SHEETS

 REGISTERED CIVIL ENGINEER
 April 20, 2018
 PLANS APPROVAL DATE
 No. C68559
 Exp. 9-30-19
 CIVIL
 STATE OF CALIFORNIA

THE STATE OF CALIFORNIA OR ITS OFFICERS OR AGENTS SHALL NOT BE RESPONSIBLE FOR THE ACCURACY OR COMPLETENESS OF SCANNED COPIES OF THIS PLAN SHEET.

TO ACCOMPANY PLANS DATED _____

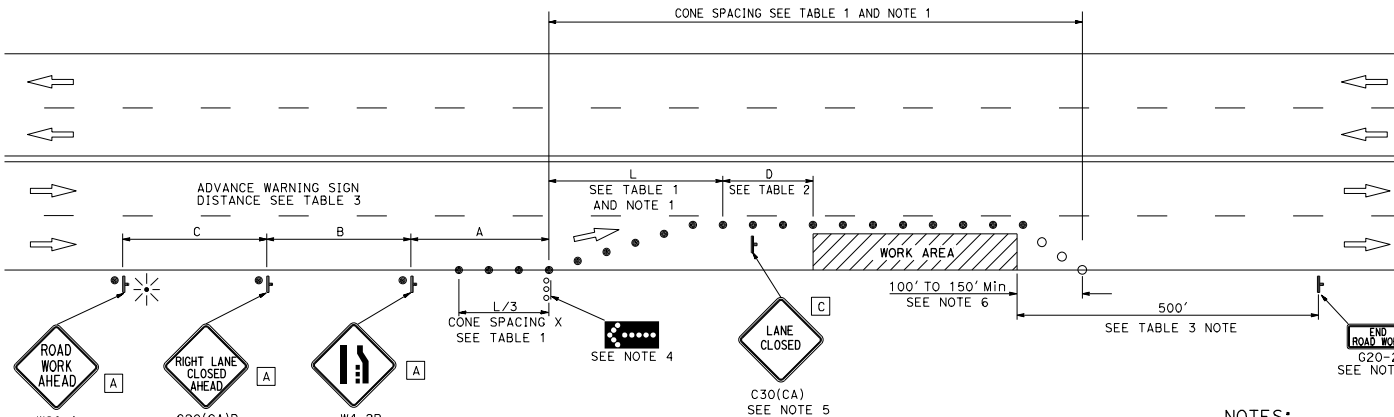

TYPICAL LANE CLOSURE

NOTES:

See Revised Standard Plan RSP T9 for tables.

Use cone spacing X for taper segment, Y for tangent segment or Z for conflict situations, as appropriate, per Table 1, unless X, Y, or Z cone spacing is shown on this sheet.



Provide at least one person to continuously maintain traffic control devices for lane closures.

NOTES:

1. Portable delineators placed at one-half the spacing indicated for traffic cones may be used instead of cones for daytime closures only.
2. Each advance warning sign shall be equipped with at least two flags for daytime closure. Each flag shall be at least 16" x 16" in size and shall be orange or fluorescent red-orange in color. Flashing beacons shall be placed at the locations indicated for lane closure during hours of darkness.
3. A G20-2 "END ROAD WORK" sign shall be placed at the end of the lane closure unless the end of work area is obvious or ends within the larger project's limits.
4. A minimum 1500' of sight distance shall be provided where possible for vehicles approaching the first flashing arrow sign. Lane closures shall not begin at the top of crest vertical curve or on a horizontal curve.

5. Place C30(CA) "LANE CLOSED" sign at 500' to 1000' intervals throughout extended work area.
6. Length may be reduced by the Engineer to address site conditions.
7. Median lane closures shall conform to the details shown except that C20(CA)L and W4-2L signs shall be used.
8. For approach speeds over 50 MPH, use the "Traffic Control System for Lane Closure on Freeways and Expressways" plan for lane closure details and requirements.

LEGEND

- TRAFFIC CONE
- TRAFFIC CONE (OPTIONAL TAPER)
- † TEMPORARY TRAFFIC CONTROL SIGN
-  FLASHING ARROW SIGN (FAS)
-  FAS SUPPORT OR TRAILER
-  PORTABLE FLASHING BEACON

SIGN PANEL SIZE (Min)

- A 48" x 48"
- B 36" x 18"
- C 30" x 30"

STATE OF CALIFORNIA
 DEPARTMENT OF TRANSPORTATION
**TRAFFIC CONTROL SYSTEM
 FOR LANE CLOSURE ON
 MULTILANE CONVENTIONAL
 HIGHWAYS**

NO SCALE

RSP T11 DATED APRIL 20, 2018 SUPERSEDES STANDARD PLAN T11
DATED OCTOBER 30, 2015 - PAGE 252 OF THE STANDARD PLANS BOOK DATED 2015.

REVISED STANDARD PLAN RSP T11

LEGEND

- TRAFFIC CONE
- ⊥ TEMPORARY TRAFFIC CONTROL SIGN
- ⬢ FLASHING ARROW SIGN (FAS)
- ☀ FAS SUPPORT OR TRAILER
- ☀ PORTABLE FLASHING BEACON

SIGN PANEL SIZE (Min)

- A 48" x 48"
- B 24" x 24"
- C 36" x 18"

NOTES:

- See Revised Standard Plan RSP T9 for tables.
- Use cone spacing X for taper segment, Y for tangent segment or Z for conflict situations, as appropriate, per Table 1, unless X, Y, or Z cone spacing is shown on this sheet.
- Provide at least one person to continuously maintain traffic control devices for lane closures.

Dist	COUNTY	ROUTE	POST MILES TOTAL PROJECT	SHEET NO.	TOTAL SHEETS

Robert D. McNew
REGISTERED CIVIL ENGINEER

April 20, 2018
PLANS APPROVAL DATE

THE STATE OF CALIFORNIA OR ITS OFFICERS OR AGENTS SHALL NOT BE RESPONSIBLE FOR THE ACCURACY OR COMPLETENESS OF SCANNED COPIES OF THIS PLAN SHEET.

REGISTERED PROFESSIONAL ENGINEER

Robert D. McNew

No. C68559

Exp. 9-30-19

CIVIL

STATE OF CALIFORNIA

TO ACCOMPANY PLANS DATED _____

TYPICAL CHANGEABLE LANE CLOSURE

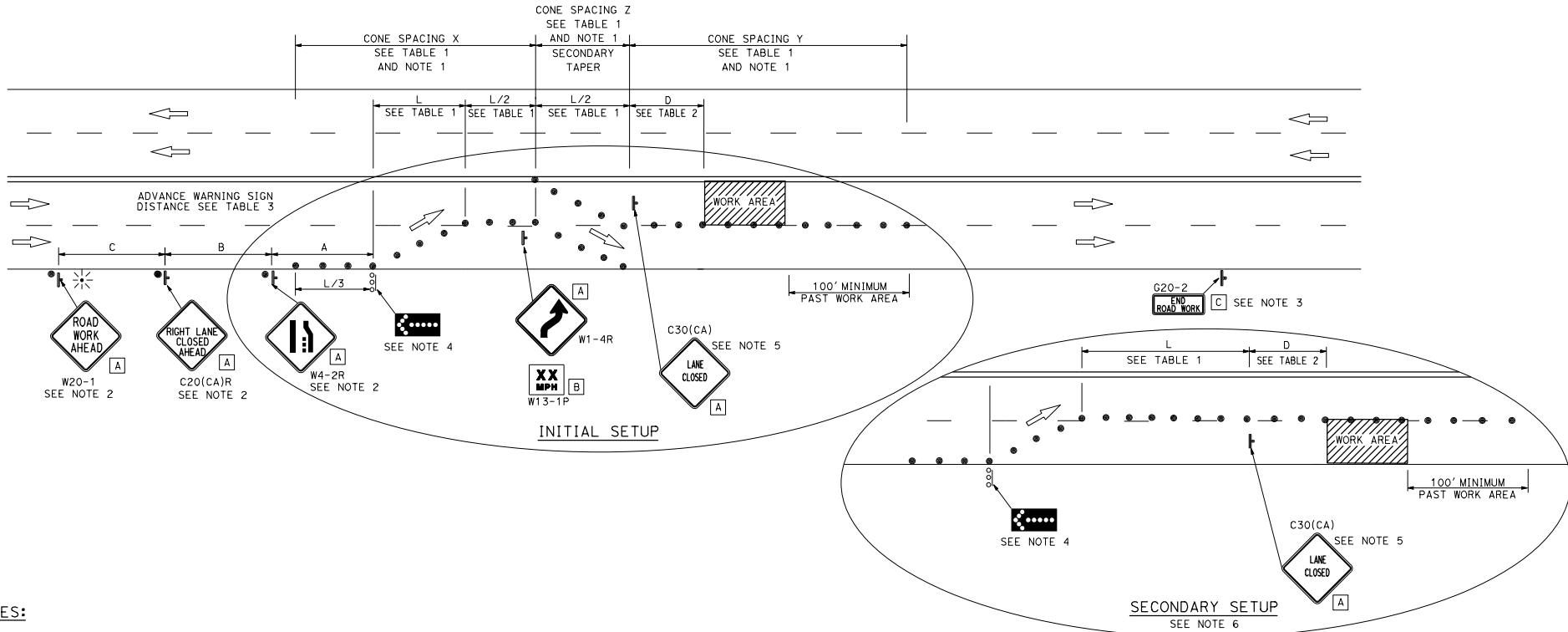

NOTES:

1. Portable delineators placed at one-half the spacing indicated for traffic cones may be used instead of cones for daytime closures only.
2. Each advance warning sign shall be equipped with at least two flags for daytime closure. Each flag shall be at least 16" x 16" in size and shall be orange or fluorescent red-orange in color. Flashing beacon shall be placed at the locations indicated for lane closure during hours of darkness.
3. A G20-2 "END ROAD WORK" sign shall be placed at the end of the lane closure unless the end of work area is obvious or ends within the larger project's limits.
4. A minimum 1500' of sight distance shall be provided where possible for vehicles approaching the first flashing arrow sign. Lane closures shall not begin at the top of crest vertical curve or on a horizontal curve.
5. Place C30(CA) "LANE CLOSED" sign at 500' to 1000' intervals throughout extended work area.
6. Relocate secondary taper to tangent location and relocate C30(CA) sign. Remove W1-4R/W13-1P sign package.

STATE OF CALIFORNIA
DEPARTMENT OF TRANSPORTATION

**TRAFFIC CONTROL SYSTEM
FOR CHANGEABLE LANE CLOSURE ON
MULTILANE CONVENTIONAL
HIGHWAYS AND EXPRESSWAYS**

NO SCALE

RSP T11A DATED APRIL 20, 2018 SUPPLEMENTS THE STANDARD PLANS BOOK DATED 2015.

REVISED STANDARD PLAN RSP T11A

LEGEND

- TRAFFIC CONE
- ⊢ TEMPORARY TRAFFIC CONTROL SIGN
- ⬛⬛⬛⬛ FLASHING ARROW SIGN (FAS)
- ☀ FAS SUPPORT OR TRAILER
- ☀ PORTABLE FLASHING BEACON

SIGN PANEL SIZE (Min)

- A 48" x 48"
- B 24" x 24"
- C 36" x 18"

NOTES:

See Revised Standard Plan RSP T9 for tables.
Use cone spacing X for taper segment, Y for tangent segment or Z for conflict situations, as appropriate, per Table 1, unless X, Y, or Z cone spacing is shown on this sheet.
Provide at least one person to continuously maintain traffic control devices for lane closures.

Dist	COUNTY	ROUTE	POST MILES TOTAL PROJECT	SHEET NO.	TOTAL SHEETS

Robert D. McNew
 REGISTERED CIVIL ENGINEER
 No. C68559
 Exp. 9-30-19
 CIVIL
 STATE OF CALIFORNIA

PLANS APPROVAL DATE: April 20, 2018
 THE STATE OF CALIFORNIA OR ITS OFFICERS OR AGENTS SHALL NOT BE RESPONSIBLE FOR THE ACCURACY OR COMPLETENESS OF SCANNED COPIES OF THIS PLAN SHEET.

TO ACCOMPANY PLANS DATED _____

TYPICAL HALF ROAD CLOSURE

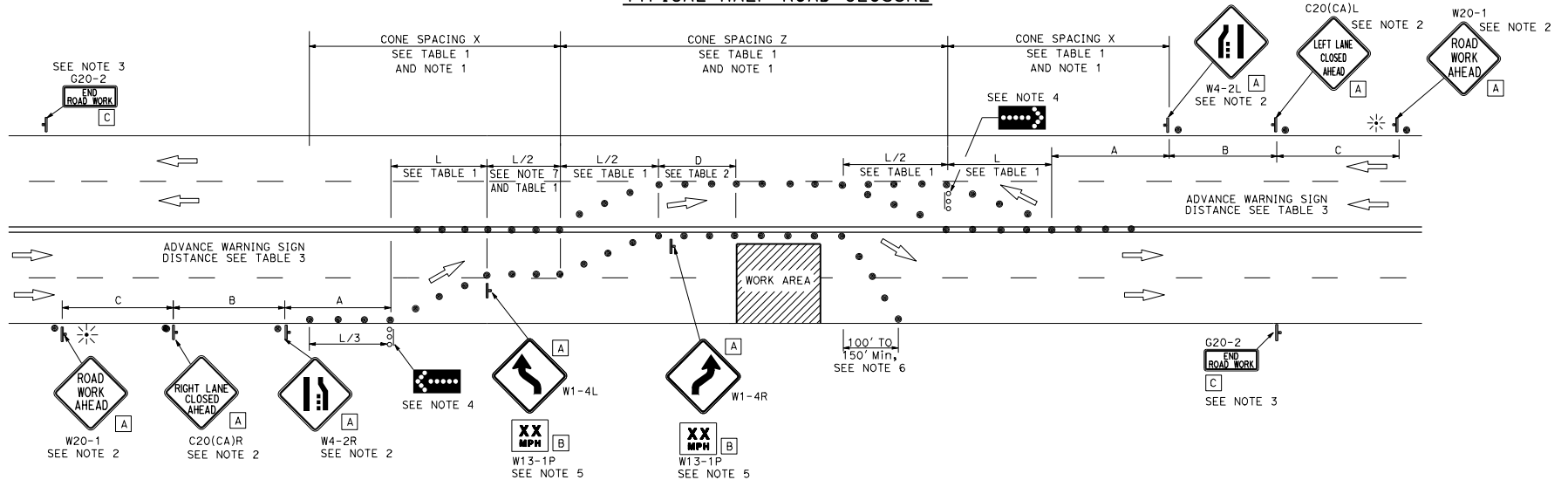

NOTES:

1. Portable delineators placed at one-half the spacing indicated for traffic cones may be used instead of cones for daytime closures only.
2. Each advance warning sign shall be equipped with at least two flags for daytime closure. Each flag shall be at least 16" x 16" in size and shall be orange or fluorescent red-orange in color. Flashing beacons shall be placed at the locations indicated for lane closure during hours of darkness.
3. A G20-2 "END ROAD WORK" sign, shall be placed at the end of the lane closure unless the end of work area is obvious or ends within the larger project's limits.
4. A minimum 1500' sight distance shall be provided where possible for vehicles approaching the first flashing arrow sign. Lane closures shall not begin at the top of crest verticle curve or on a horizontal curve.
5. Advisory speed will be determined by the Engineer, The W13-1P Plaque will not be required when advisory speed is more than the posted or maximum speed limit.
6. Length may be reduced by the Engineer to address site conditions.
7. The tangent (L/2) shall be used.

STATE OF CALIFORNIA
DEPARTMENT OF TRANSPORTATION

**TRAFFIC CONTROL SYSTEM
FOR HALF ROAD CLOSURE ON
MULTILANE CONVENTIONAL
HIGHWAYS AND EXPRESSWAYS**

NO SCALE

RSP T12 DATED APRIL 20, 2018 SUPERSEDES STANDARD PLAN T12
DATED OCTOBER 30, 2015 - PAGE 253 OF THE STANDARD PLANS BOOK DATED 2015.

REVISED STANDARD PLAN RSP T12

2015 REVISED STANDARD PLAN RSP T12

NOTES:

See Revised Standard Plan RSP T9 for tables.

Use cone spacing X for taper segment, Y for tangent segment or Z for conflict situations, as appropriate, per Table 1, unless X, Y, or Z cone spacing is shown on this sheet.

Provide at least one person to continuously maintain traffic control devices for lane closures.

DIST	COUNTY	ROUTE	POST MILES	SHEET TOTAL
			TOTAL PROJECT	NO. SHEETS
REGISTERED CIVIL ENGINEER Robert D. McNew No. C68559 Exp. 9-30-19 CIVIL STATE OF CALIFORNIA				
APRIL 20, 2018 PLANS APPROVAL DATE THE STATE OF CALIFORNIA OR ITS OFFICERS OR AGENTS SHALL NOT BE RESPONSIBLE FOR THE ACCURACY OR COMPLETENESS OF SCANNED COPIES OF THIS PLAN SHEET.				

TYPICAL LANE CLOSURE WITH REVERSIBLE CONTROL

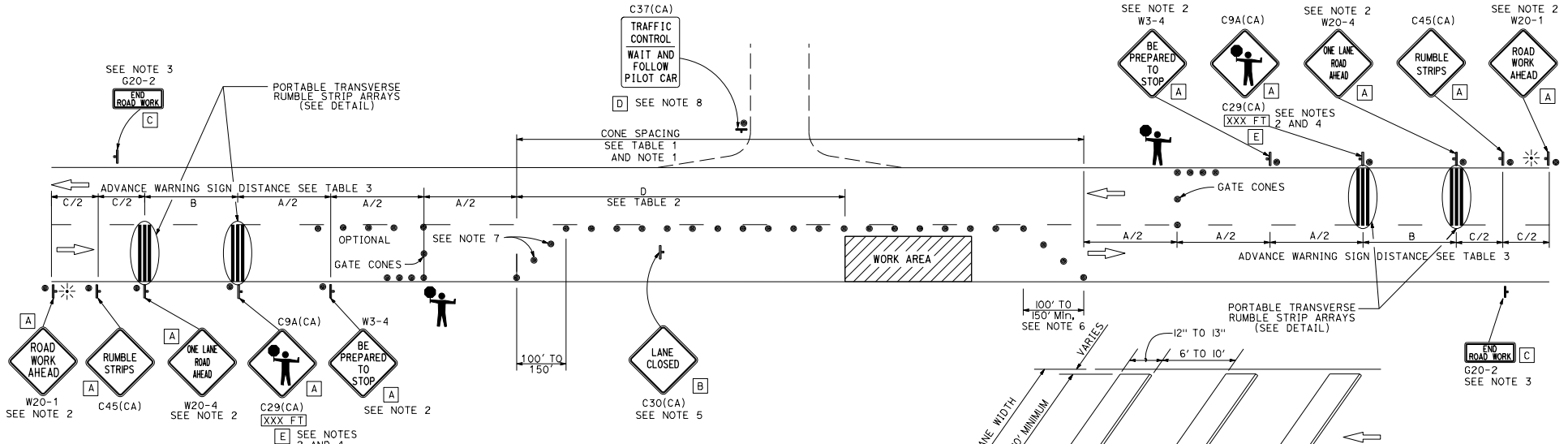

NOTES:

- Portable delineators placed at one-half the spacing indicated for traffic cones may be used instead of cones for daytime closures only.
- Each advance warning sign shall be equipped with at least two flags for daytime closure. Each flag shall be at least 16" x 16" in size and shall be orange or fluorescent red-orange in color. Flashing beacons shall be placed at the locations indicated for lane closure during hours of darkness.
- A G20-2 "END ROAD WORK" sign, shall be placed at the end of the lane closure unless the end of work area is obvious or ends within the larger project's limits.
- An optional C29(CA) sign may be placed below the C9A(CA) sign.
- Place C30(CA) "LANE CLOSED" sign at 500' to 1000' intervals throughout extended work area. They are optional if the work area is visible from the flagger station.
- Length may be reduced by the Engineer to address site conditions.
- Either traffic cones or barricades shall be placed on the taper. Barricades shall be Type I, II, or III.
- When a pilot car is used, place a C37(CA) "TRAFFIC CONTROL-WAIT AND FOLLOW PILOT CAR" sign with black legend on white background at all intersections, driveways and alleys without a flagger within the traffic control area.

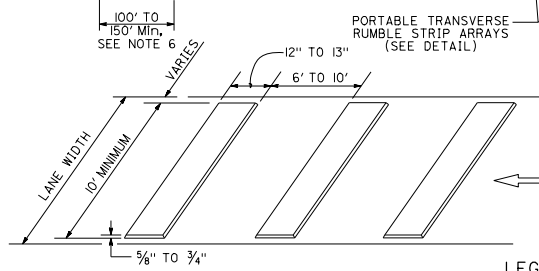

LEGEND

- TRAFFIC CONE
- ⊥ TEMPORARY TRAFFIC CONTROL SIGN
- ⚡ PORTABLE FLASHING BEACON
- 🚧 FLAGGER

**STATE OF CALIFORNIA
DEPARTMENT OF TRANSPORTATION**

**TRAFFIC CONTROL SYSTEM
FOR LANE CLOSURE ON
TWO LANE CONVENTIONAL
HIGHWAYS**

NO SCALE

RSP T13 DATED APRIL 20, 2018 SUPERSEDES STANDARD PLAN T13
DATED OCTOBER 30, 2015 - PAGE 254 OF THE STANDARD PLANS BOOK DATED 2015.

REVISD STANDARD PLAN RSP T13

2015 REVISED STANDARD PLAN RSP T13

TYPICAL RAMP CLOSURES

SIGN PANEL SIZE (Min)

- A 48" x 48"
- B 48" x 30"
- C 36" x 36"
- D 48" x 36"

LEGEND

- TRAFFIC CONE
- ⊥ TEMPORARY TRAFFIC CONTROL SIGN
- ⊥ BARRICADES
- ⊛ PORTABLE FLASHING BEACON

DIST	COUNTY	ROUTE	POST MILES TOTAL PROJECT	SHEET NO.	TOTAL SHEETS

REGISTERED CIVIL ENGINEER Robert D. McNew No. C68559 Exp. 9-30-19 CIVIL STATE OF CALIFORNIA	
PLANS APPROVAL DATE April 20, 2018	
THE STATE OF CALIFORNIA OR ITS OFFICERS OR AGENTS SHALL NOT BE RESPONSIBLE FOR THE ACCURACY OR COMPLETENESS OF SCANNED COPIES OF THIS PLAN SHEET.	

TO ACCOMPANY PLANS DATED _____

NOTES:

- Portable delineators placed at one-half the spacing indicated for traffic cones may be used instead of cones for daytime closures only.
- Each advance warning C19(CA) "RAMP CLOSED AHEAD" sign shall be equipped with at least two flags for daytime closure. Each flag shall be at least 16" x 16" in size and shall be orange or fluorescent red-orange in color. A flashing beacon shall be placed on top of the first C19(CA) sign during hours of darkness.
- Barricades shall be Type I, II or III for closures lasting one week or less and Type III for closures lasting longer than one week.
- In addition to placing the C19(CA) "RAMP CLOSED AHEAD" and C30(CA) "RAMP CLOSED" signs, black on orange overlay plates with the word "closed" may be mounted. As directed by the Engineer on all guide signs that refer to the closed ramp. The letter size on the overlay shall be the same as the guide sign.
- The existing "EXIT" signs shall be covered during ramp closures.
- A minimum of 3 cones shall be placed transversely across each closed lane and shoulder.
- C2(CA) sign shall be black and white.

2015 REVISED STANDARD PLAN RSP T14

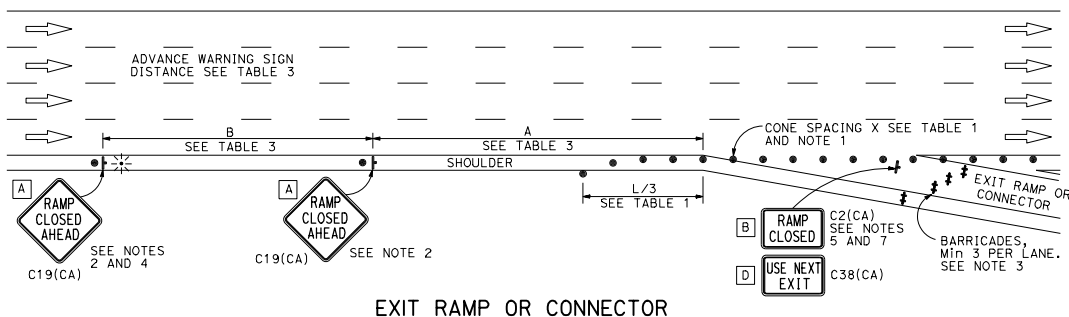

EXIT RAMP OR CONNECTOR

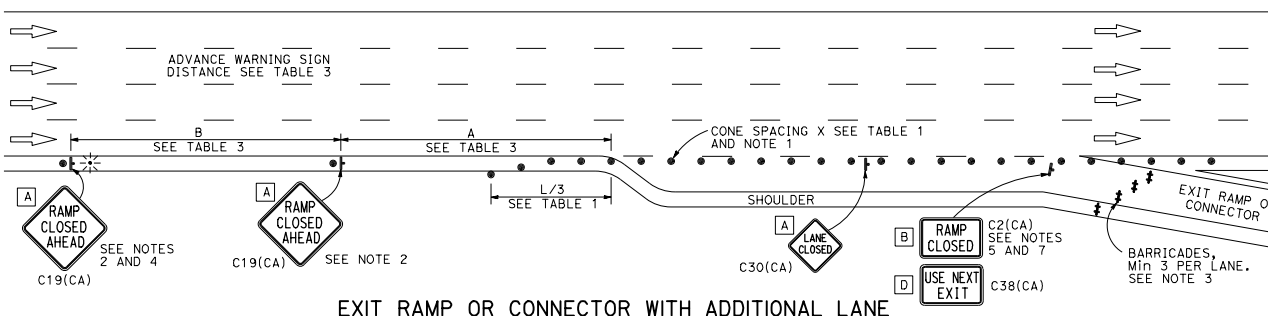

EXIT RAMP OR CONNECTOR WITH ADDITIONAL LANE

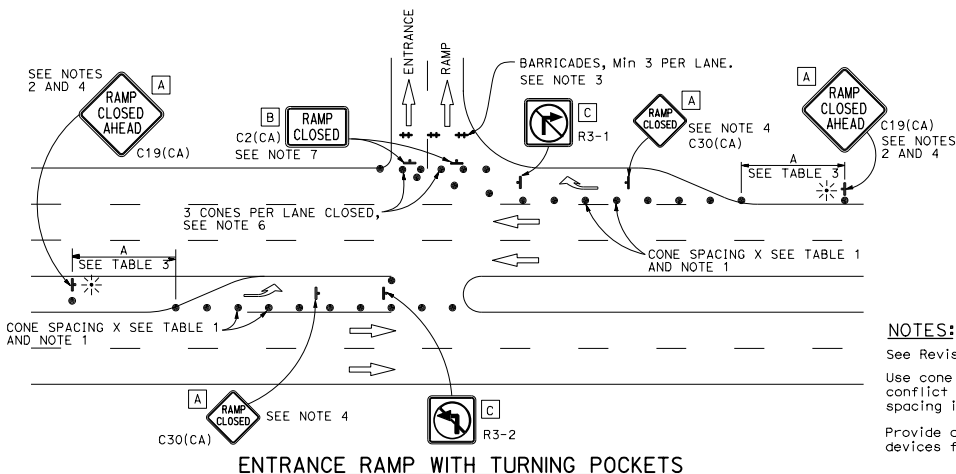

ENTRANCE RAMP WITH TURNING POCKETS

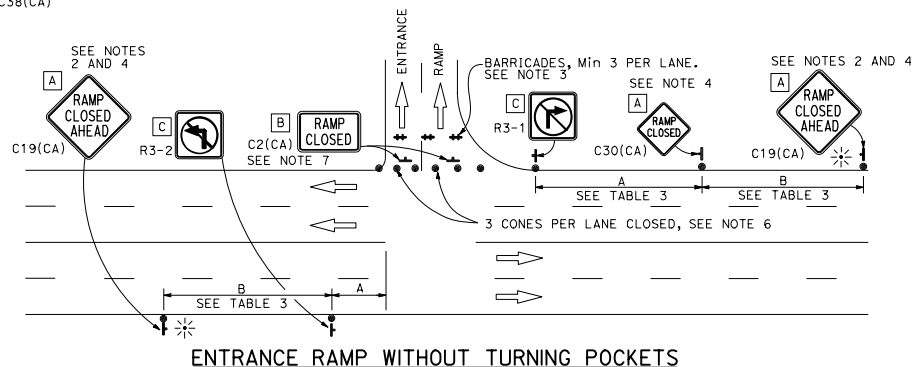

ENTRANCE RAMP WITHOUT TURNING POCKETS

NOTES:

- See Revised Standard Plan RSP T9 for tables.
- Use cone spacing X for taper segment, Y for tangent segment or Z for conflict situations, as appropriate, per Table 1, unless X, Y, or Z cone spacing is shown on this sheet.
- Provide at least one person to continuously maintain traffic control devices for lane closures.

STATE OF CALIFORNIA
DEPARTMENT OF TRANSPORTATION
**TRAFFIC CONTROL SYSTEM
FOR RAMP CLOSURE**
NO SCALE

RSP T14 DATED APRIL 20, 2018 SUPERSEDES STANDARD PLAN T14
DATED OCTOBER 30, 2015 - PAGE 255 OF THE STANDARD PLANS BOOK DATED 2015.

REVISED STANDARD PLAN RSP T14

NOTES:

1. Only signs related to pedestrians are shown. For all other signs see appropriate T-sheets.
2. Barricades closing sidewalk shall cover the full width of the sidewalk. Use R9-11 sign when there are destination points between the detour and the work area. Locate the R9-11 sign to allow pedestrian access.
3. Advance warning sign is not required if the work area is within the limits of a larger work zone. Sign shall be equipped with at least two flags for daytime closure. Each flag shall be orange or fluorescent red-orange in color.

NOTES:

See Revised Standard Plan RSP T9 for tables.
Use cone spacing X for taper segment, Y for tangent segment or Z for conflict situations, as appropriate, per Table 1 unless X, Y, or Z cone spacing is shown on this sheet.

Dist	COUNTY	ROUTE	POST MILES TOTAL PROJECT	SHEET TOTAL NO. SHEETS

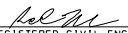
 REGISTERED CIVIL ENGINEER
 No. C68559
 Exp. 9-30-17
 CIVIL
 STATE OF CALIFORNIA

July 21, 2017
 PLANS APPROVAL DATE
THE STATE OF CALIFORNIA OR ITS OFFICERS OR AGENTS SHALL NOT BE RESPONSIBLE FOR THE ACCURACY OR COMPLETENESS OF SCANNED COPIES OF THIS PLAN SHEET.

TO ACCOMPANY PLANS DATED _____

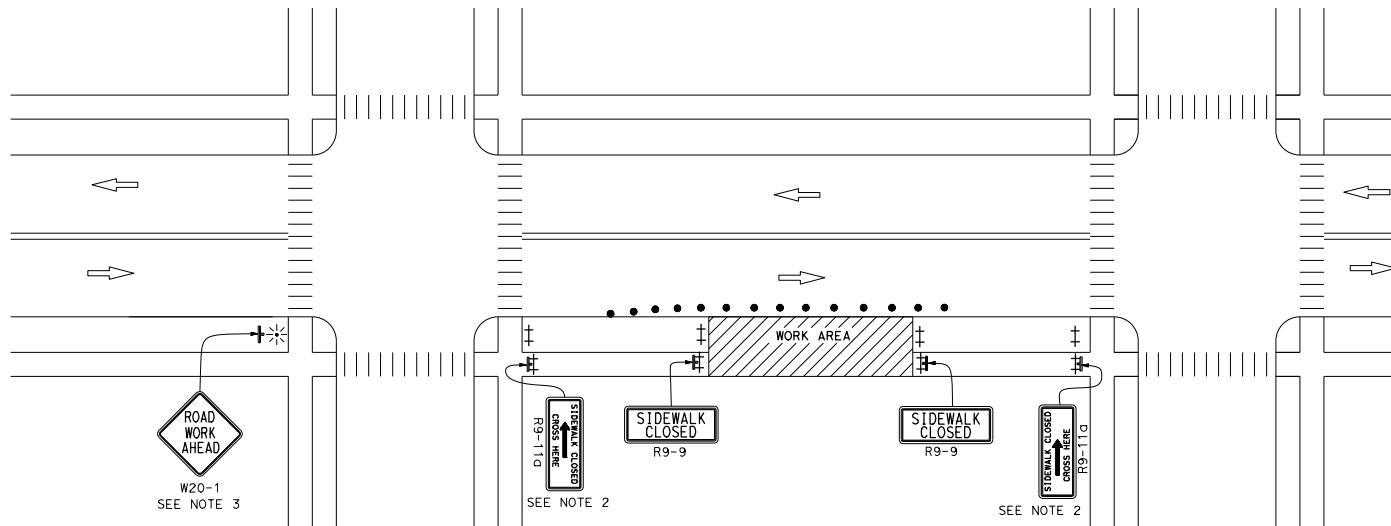

LEGEND:

- ⊥ BARRICADE
- TRAFFIC CONE
- ⚡ PORTABLE FLASHING BEACON
- ⊥ SIGN
- ⊥ TEMPORARY TRAFFIC CONTROL SIGN ON BARRICADE

SIGN PANEL SIZE (Min)

SIGN DESIGNATION	SIGN OR PLAQUE	SIGN SIZE
R9-9	SIDEWALK CLOSED	24" x 12"
R9-11	SIDEWALK CLOSED AHEAD CROSS HERE	24" x 18"
R9-11a	SIDEWALK CLOSED CROSS HERE	24" x 12"
W20-1	ROAD WORK AHEAD	36" x 36"

STATE OF CALIFORNIA
DEPARTMENT OF TRANSPORTATION

**TEMPORARY PEDESTRIAN ACCESS ROUTES
TYPICAL SIDEWALK CLOSURE
AND PEDESTRIAN DETOUR**

NO SCALE

RSP T30 DATED JULY 21, 2017 SUPPLEMENTS THE STANDARD PLANS BOOK DATED 2015.

REVISED STANDARD PLAN RSP T30

NOTES:

1. Only signs related to pedestrians are shown. For all other signs see appropriate T-sheets.
2. Separate pedestrian walkway from traffic and work zone activities, when temporary walkway is adjacent to traffic.
3. The temporary pedestrian access route must not lead into conflict with vehicles or work.
4. Advance warning sign is not required if the work area is within the limits of a larger work zone. Sign shall be equipped with at least two flags for daytime closure. Each flag shall be orange or fluorescent red-orange in color.
5. All devices used to channelize pedestrian flow must connect such that gaps do not allow pedestrians to stray from the channelized path.
6. Barricades closing sidewalk shall cover the full width of the sidewalk.
7. Separate the temporary pedestrian access route from traffic using a temporary barrier and a crash cushion if necessary.
8. When it is not possible to maintain a minimum of 60 inches throughout the length of the pedestrian route, maintain a minimum width of 48 inches and provide a 60 X 60-inch passing space at least every 200 feet.
9. See Revised Standard Plan RSP A88A for detectable warning surface for curb ramps to apply to temporary curb ramps.
10. See Revised Standard Plan RSP T34 for temporary curb ramp options.

NOTES:

See Revised Standard Plan RSP T9 for tables.
Use cone spacing X for taper segment, Y for tangent segment or Z for conflict situations, as appropriate, per Table 1 unless X, Y, or Z cone spacing is shown on this sheet.

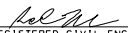
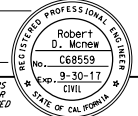
Dist	COUNTY	ROUTE	POST MILES TOTAL PROJECT	SHEET TOTAL SHEETS
 REGISTERED CIVIL ENGINEER				
July 21, 2017 PLANS APPROVAL DATE				
				
THE STATE OF CALIFORNIA OR ITS OFFICERS OR AGENTS SHALL NOT BE RESPONSIBLE FOR THE ACCURACY OR COMPLETENESS OF SCANNED COPIES OF THIS PLAN SHEET.				

TO ACCOMPANY PLANS DATED _____

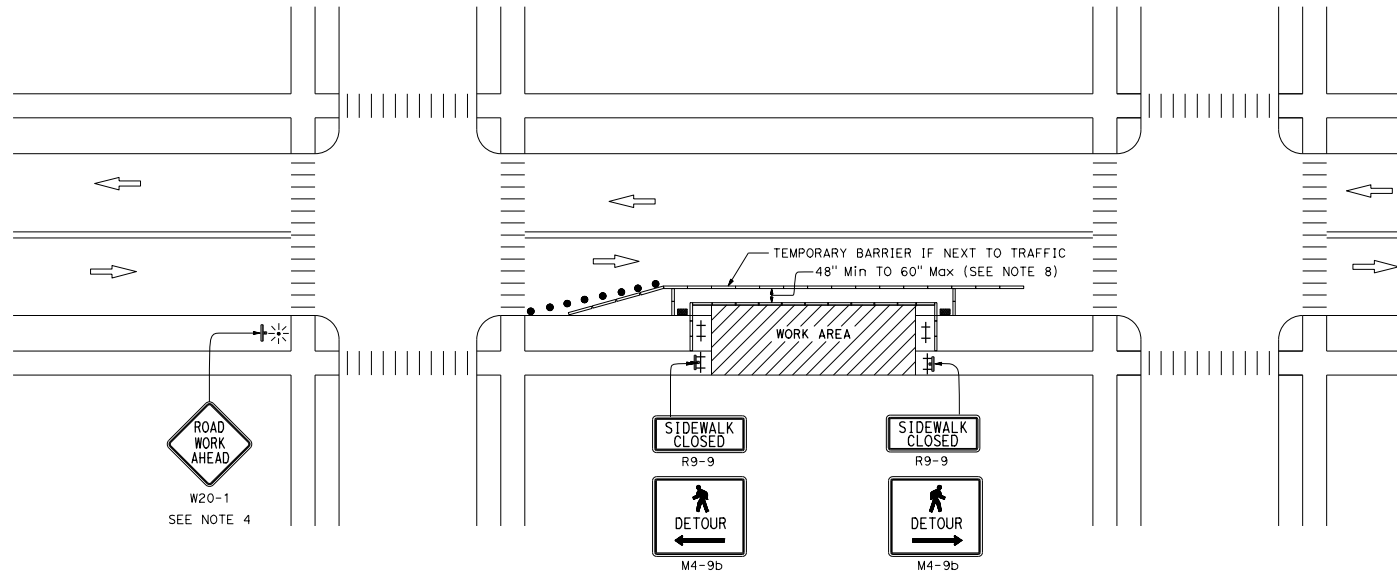

LEGEND:

- ⊥ BARRICADE
- ▬ TEMPORARY CURB RAMP
- ▬ CHANNELIZING DEVICE
- TRAFFIC CONE
- ⊛ PORTABLE FLASHING BEACON
- ⊥ TEMPORARY TRAFFIC CONTROL SIGN
- ⊥ TEMPORARY TRAFFIC CONTROL SIGN ON BARRICADE

SIGN PANEL SIZE (Min)

SIGN DESIGNATION	SIGN OR PLAQUE	SIGN SIZE
M4-9b	PEDESTRIAN DETOUR	30" x 24"
R9-9	SIDEWALK CLOSED	24" x 12"
W20-1	ROAD WORK AHEAD	36" x 36"

STATE OF CALIFORNIA
DEPARTMENT OF TRANSPORTATION

**TEMPORARY PEDESTRIAN ACCESS ROUTES
TYPICAL SIDEWALK DIVERSION WITHIN ROADBED**

NO SCALE

RSP T31 DATED JULY 21, 2017 SUPPLEMENTS THE STANDARD PLANS BOOK DATED 2015.

REVISED STANDARD PLAN RSP T31

2015 REVISED STANDARD PLAN RSP T31

NOTES:

1. Only signs related to pedestrians are shown. For all other signs see appropriate T-sheets.
2. Barricades closing sidewalk shall cover the full width of the sidewalk. Use R9-11 sign when there are destination points between the detour and the work area. Locate the R9-11 sign to allow pedestrian access.
3. Advance warning sign is not required if the work area is within the limits of a larger work zone. Sign shall be equipped with at least two flags for daytime closure. Each flag shall be orange or fluorescent red-orange in color.

NOTES:

See Revised Standard Plan RSP T9 for tables.
Use cone spacing X for taper segment, Y for tangent segment or Z for conflict situations, as appropriate, per Table 1 unless X,Y, or Z cone spacing is shown on this sheet.

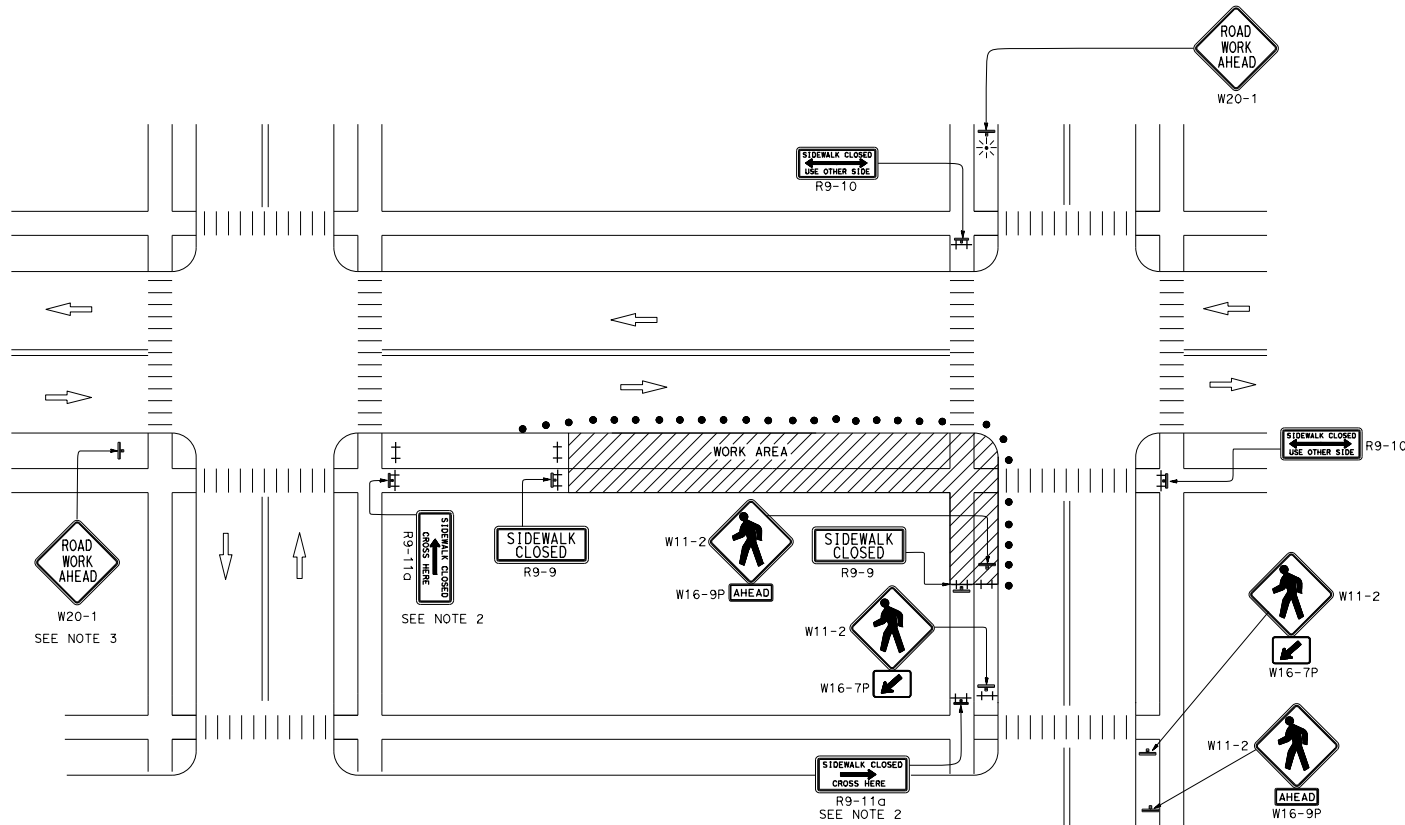

DIST	COUNTY	ROUTE	POST MILES TOTAL PROJECT	SHEET TOTAL SHEETS

Robert D. McNew
 REGISTERED CIVIL ENGINEER
 No. C68559
 Exp. 9-30-17
 CIVIL
 STATE OF CALIFORNIA

July 21, 2017
 PLANS APPROVAL DATE
 THE STATE OF CALIFORNIA OR ITS OFFICERS OR AGENTS SHALL NOT BE RESPONSIBLE FOR THE ACCURACY OR COMPLETENESS OF SCANNED COPIES OF THIS PLAN SHEET.

TO ACCOMPANY PLANS DATED _____

LEGEND:

- ⊥ BARRICADE
- TRAFFIC CONE
- ⊛ PORTABLE FLASHING BEACON
- ⊥ TEMPORARY TRAFFIC CONTROL SIGN
- ⊥ TEMPORARY TRAFFIC CONTROL SIGN ON BARRICADE

SIGN PANEL SIZE (Min)

SIGN DESIGNATION	SIGN OR PLAQUE	SIGN SIZE
R9-9	SIDEWALK CLOSED	24" x 12"
R9-10	SIDEWALK CLOSED USE OTHER SIDE	24" x 12"
R9-11	SIDEWALK CLOSED AHEAD CROSS HERE	24" x 18"
R9-11a	SIDEWALK CLOSED CROSS HERE	24" x 12"
W11-2	PEDESTRIAN	36" x 36"
W16-7P	DIAGONAL DOWNWARD POINTING ARROW (PLAQUE)	24" x 12"
W16-9P	AHEAD (PLAQUE)	24" x 12"
W20-1	ROAD WORK AHEAD	36" x 36"

STATE OF CALIFORNIA
DEPARTMENT OF TRANSPORTATION

**TEMPORARY PEDESTRIAN ACCESS ROUTES
TYPICAL SIDEWALK/CROSSWALK CLOSURE
AND PEDESTRIAN DETOUR**

NO SCALE

RSP T32 DATED JULY 21, 2017 SUPPLEMENTS THE STANDARD PLANS BOOK DATED 2015.

REVISED STANDARD PLAN RSP T32

2015 REVISED STANDARD PLAN RSP T32

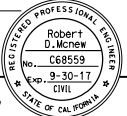
Dist	COUNTY	ROUTE	POST MILES TOTAL PROJECT	SHEET NO.	TOTAL SHEETS
 REGISTERED CIVIL ENGINEER July 21, 2017 PLANS APPROVAL DATE THE STATE OF CALIFORNIA OR ITS OFFICERS OR AGENTS SHALL NOT BE RESPONSIBLE FOR THE ACCURACY OR COMPLETENESS OF SCANNED COPIES OF THIS PLAN SHEET.					
					

RAMP				HAND RAIL		EDGE PROTECTION	
SLOPE	CROSS SLOPE	WIDTH	LENGTH	HEIGHT RIGHT SIDE	HEIGHT LEFT SIDE	RAIL RIGHT SIDE	RAIL LEFT SIDE
A	B	C	D	E	F	G	H
8.3% OR LESS	2.0% OR LESS	48 INCHES OR GREATER	30 FEET OR LESS	34 TO 38 INCHES	34 TO 38 INCHES	WITHIN 2 INCHES FROM GROUND	WITHIN 2 INCHES FROM GROUND
TOP LANDING				BOTTOM LANDING			
CROSS SLOPE	SLOPE	WIDTH	DEPTH	CROSS SLOPE	SLOPE	WIDTH	DEPTH
I	J	K	L	M	N	O	P
2.0% OR LESS	2.0% OR LESS	48 INCHES OR GREATER	60 INCHES OR GREATER	2.0% OR LESS	2.0% OR LESS	48 INCHES OR GREATER	60 INCHES OR GREATER

TO ACCOMPANY PLANS DATED _____

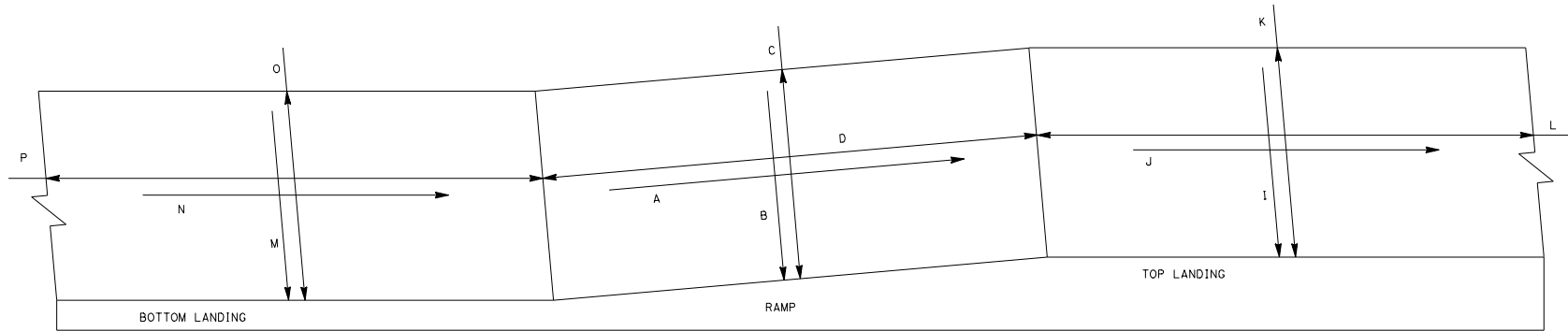

STATE OF CALIFORNIA
DEPARTMENT OF TRANSPORTATION
**TEMPORARY PEDESTRIAN
ACCESS ROUTES
RAMP**
NO SCALE

RSP T33 DATED JULY 21, 2017 SUPPLEMENTS THE STANDARD PLANS BOOK DATED 2015.

REVISED STANDARD PLAN RSP T33

2015 REVISED STANDARD PLAN RSP T33

CURB RAMP			TOP LANDING				DETECTABLE WARNING SURFACE
SLOPE	CROSS SLOPE	WIDTH	CROSS SLOPE	SLOPE	WIDTH	DEPTH	DEPTH
A	B	C	D	E	F	G	K
8.3% OR LESS	2.0% OR LESS	48 INCHES OR GREATER	2.0% OR LESS	2.0% OR LESS	48 INCHES OR GREATER	60 INCHES OR GREATER	MINIMUM 36 INCHES

NOTES: If the above requirements cannot be met, on existing sites with space limitations, the following slopes are allowed:
For a maximum rise of 6 inches a slope between 1:12 to 1:10 is allowed.
For a maximum rise of 3 inches a slope between 1:10 to 1:8 is allowed.

Dist	COUNTY	ROUTE	POST MILES TOTAL PROJECT	SHEET TOTAL SHEETS



 REGISTERED CIVIL ENGINEER
 July 21, 2017
 PLANS APPROVAL DATE
THE STATE OF CALIFORNIA OR ITS OFFICERS OR AGENTS SHALL NOT BE RESPONSIBLE FOR THE ACCURACY OR COMPLETENESS OF SCANNED COPIES OF THIS PLAN SHEET.

REGISTERED PROFESSIONAL ENGINEER
 Robert D. McNew
 No. C68559
 Exp. 9-30-17
 CIVIL
 STATE OF CALIFORNIA

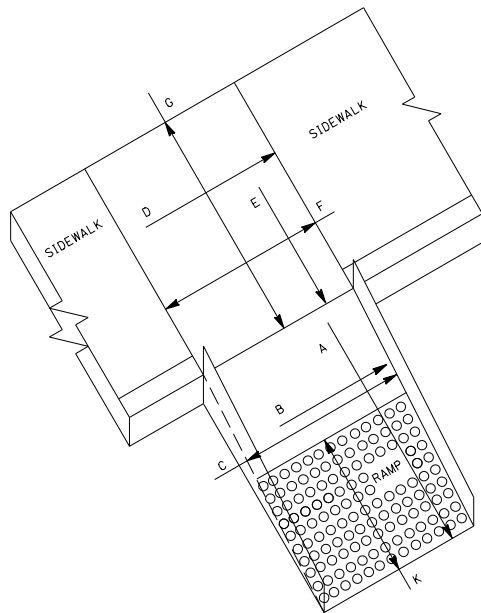
TO ACCOMPANY PLANS DATED _____

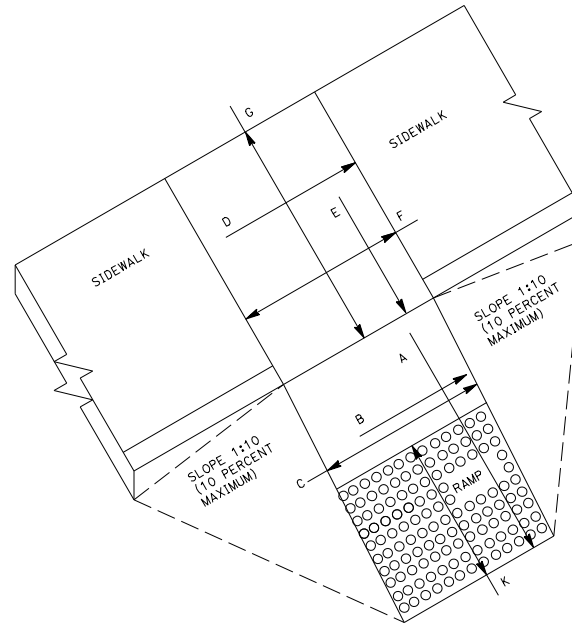

OPTION A
SHOWN WITH SIDE EDGE



OPTION B
SHOWN WITH SIDE APRON

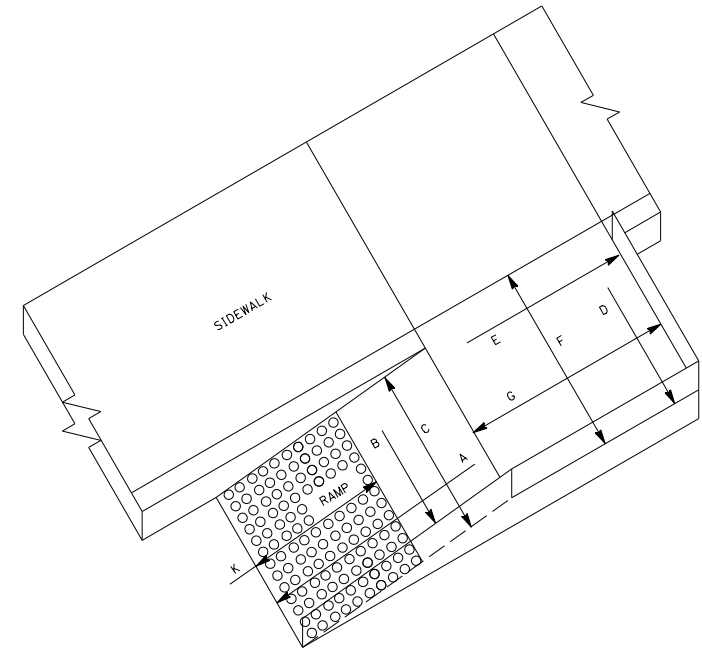

OPTION C
PARALLEL RAMP
SHOWN WITH SIDE EDGE

STATE OF CALIFORNIA
DEPARTMENT OF TRANSPORTATION
**TEMPORARY PEDESTRIAN
ACCESS ROUTES
CURB RAMP OPTIONS**

NO SCALE

RSP T34 DATED JULY 21, 2017 SUPPLEMENTS THE STANDARD PLANS BOOK DATED 2015.

REVISED STANDARD PLAN RSP T34

2015 REVISED STANDARD PLAN RSP T34

DIST	COUNTY	ROUTE	POST MILES TOTAL PROJECT	SHEET TOTAL NO. SHEETS

Robert B. Abbott
 LICENSED LANDSCAPE ARCHITECT
 January 20, 2017
 PLANS APPROVAL DATE
THE STATE OF CALIFORNIA OR ITS OFFICERS OR AGENTS SHALL NOT BE RESPONSIBLE FOR THE ACCURACY OR COMPLETENESS OF SCANNED COPIES OF THIS PLAN SHEET.

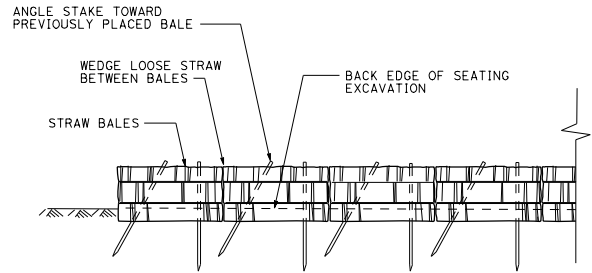

FRONT ELEVATION

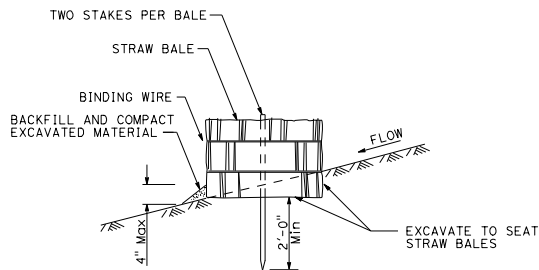

SECTION

TEMPORARY STRAW BALE BARRIER

NOTE:

- 1. Temporary silt fence and temporary high-visibility fence shown for reference purposes only.

TO ACCOMPANY PLANS DATED _____

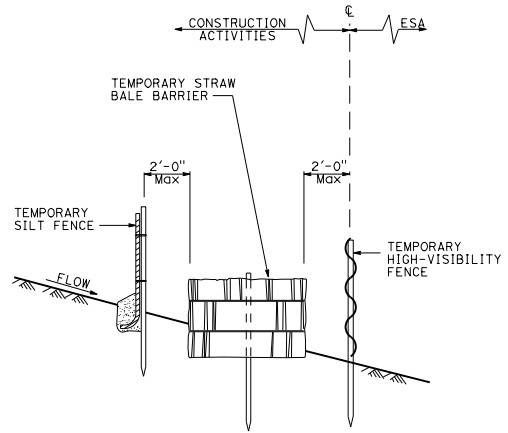

SECTION
**PLACEMENT DETAIL
FOR TEMPORARY SILT FENCE
AND TEMPORARY HIGH-VISIBILITY FENCE
USED WITH TEMPORARY STRAW BALE BARRIER**
(See Note 1)

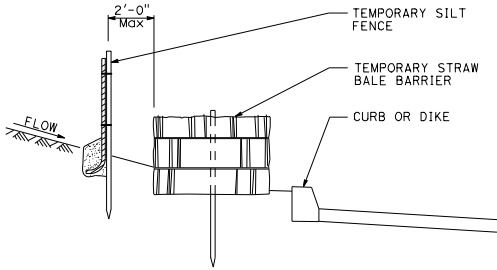

SECTION
**PLACEMENT DETAIL
FOR TEMPORARY SILT FENCE
USED WITH TEMPORARY
STRAW BALE BARRIER**
(See Note 1)

STATE OF CALIFORNIA
DEPARTMENT OF TRANSPORTATION
**TEMPORARY WATER POLLUTION
CONTROL DETAILS
(TEMPORARY STRAW BALE BARRIER)**
NO SCALE

RSP T52 DATED JANUARY 20, 2017 SUPERSEDES STANDARD PLAN T52
DATED OCTOBER 30, 2015 - PAGE 260 OF THE STANDARD PLANS BOOK DATED 2015.

REVISED STANDARD PLAN RSP T52

2015 REVISED STANDARD PLAN RSP T52

DIST	COUNTY	ROUTE	POST MILES TOTAL PROJECT	SHEET NO.	TOTAL SHEETS

Robert B. Abbott
 LICENSED LANDSCAPE ARCHITECT
 January 20, 2017
 PLANS APPROVAL DATE
THE STATE OF CALIFORNIA OR ITS OFFICERS OR AGENTS SHALL NOT BE RESPONSIBLE FOR THE ACCURACY OR COMPLETENESS OF SCANNED COPIES OF THIS PLAN SHEET.

TO ACCOMPANY PLANS DATED _____

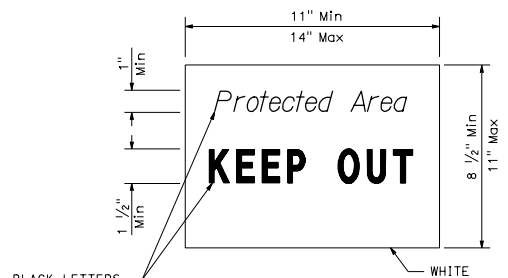

SIGN DETAIL

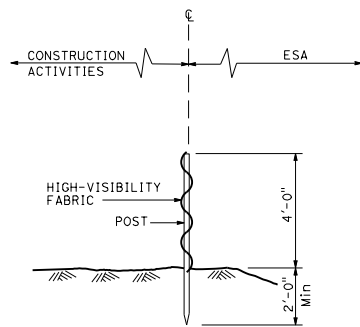

SECTION
TEMPORARY HIGH-VISIBILITY FENCE

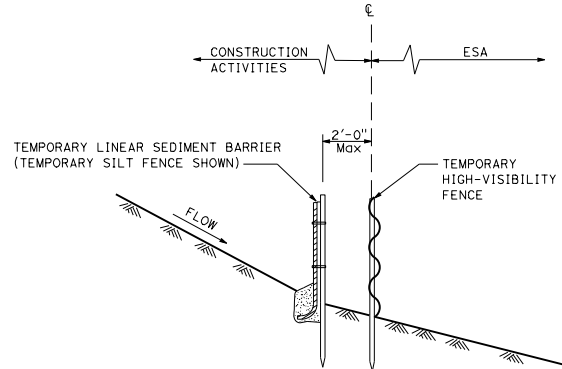

SECTION
PLACEMENT DETAIL
FOR TEMPORARY LINEAR SEDIMENT BARRIER
USED WITH TEMPORARY
HIGH-VISIBILITY FENCE

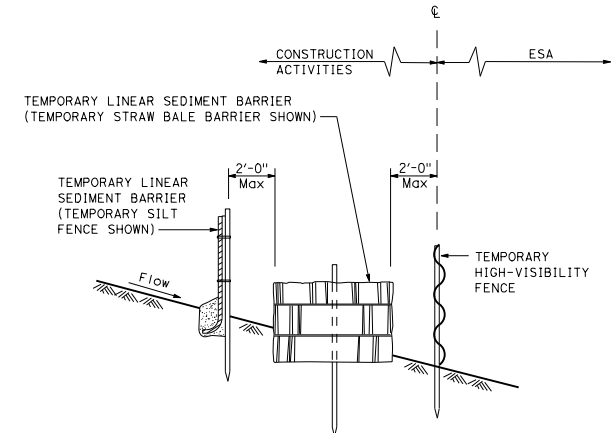

SECTION
PLACEMENT DETAIL
FOR TEMPORARY SILT FENCE
AND TEMPORARY STRAW BALE
USED WITH TEMPORARY HIGH-VISIBILITY FENCE

STATE OF CALIFORNIA
DEPARTMENT OF TRANSPORTATION
TEMPORARY WATER POLLUTION CONTROL DETAILS
(TEMPORARY HIGH-VISIBILITY FENCE)

NO SCALE
RSP T65 DATED JANUARY 20, 2017 SUPERSEDES STANDARD PLAN T65
DATED OCTOBER 30, 2015 - PAGE 273 OF THE STANDARD PLANS BOOK DATED 2015.

REVISED STANDARD PLAN RSP T65

2015 REVISED STANDARD PLAN RSP T65

DIST	COUNTY	ROUTE	POST MILES TOTAL PROJECT	SHEET NO.	TOTAL SHEETS

Robert B. Abbott
 LICENSED LANDSCAPE ARCHITECT
 January 20, 2017
 PLANS APPROVAL DATE
THE STATE OF CALIFORNIA OR ITS OFFICERS OR AGENTS SHALL NOT BE RESPONSIBLE FOR THE ACCURACY OR COMPLETENESS OF SCANNED COPIES OF THIS PLAN SHEET.



TO ACCOMPANY PLANS DATED _____

NOTES:

1. Temporary high-visibility fence shown for reference purposes only.
2. Setback dimension may vary according to field conditions or as designated on plans.

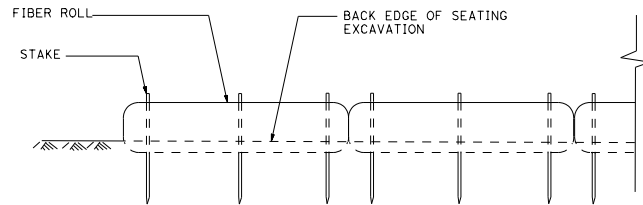

FRONT ELEVATION

TEMPORARY LARGE SEDIMENT BARRIER

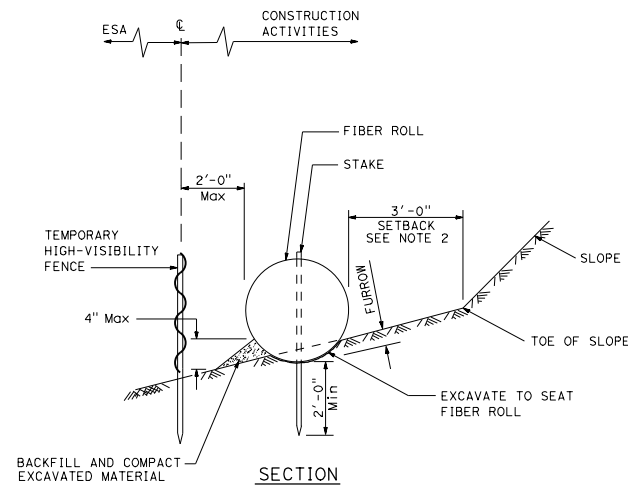

SECTION

PLACEMENT DETAIL
FOR TEMPORARY HIGH-VISIBILITY FENCE
USED WITH TEMPORARY LARGE SEDIMENT BARRIER

(See Note 1)

STATE OF CALIFORNIA
DEPARTMENT OF TRANSPORTATION

**TEMPORARY WATER POLLUTION
CONTROL DETAILS
(TEMPORARY LARGE SEDIMENT BARRIER)**

NO SCALE

RSP T66 DATED JANUARY 20, 2017 SUPERSEDES STANDARD PLAN T66
DATED OCTOBER 30, 2015 - PAGE 274 OF THE STANDARD PLANS BOOK DATED 2015.

REVISED STANDARD PLAN RSP T66

2015 REVISED STANDARD PLAN RSP T66