

DEPARTMENT OF PUBLIC WORKS AND PLANNING
SHOULDER IMPROVEMENTS X-SECTIONS
DRAWING NO. ###
SHEET NO. C2
TOTAL ###

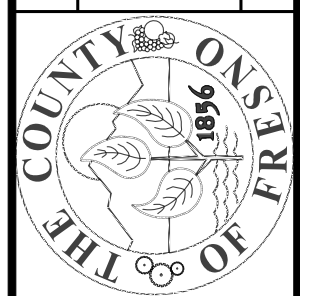

PROJECT
JENSEN AVENUE SHOULDER
IMPROVEMENTS & OVERLAY
MADARA AVE TO DICKENSON AVE
ROAD NO. ###
BRIDGE NO. ###

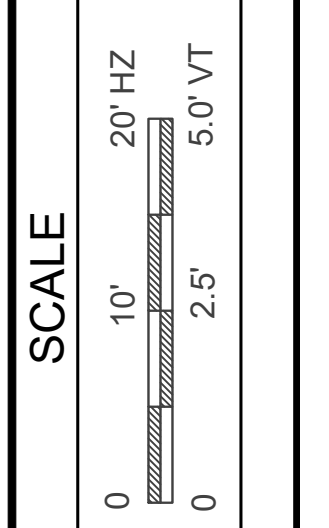

DATE
2/2020
2/2020
2/2020
DESIGNED: B.KHALIQ
DRAWN: B.KHALIQ
CHECKED: S.ARTAL

THESE CROSS SECTIONS ARE FOR THE CONTRACTOR'S INFORMATION ONLY. THEY ARE NOT TO BE CONSIDERED TO BE PART OF THE CONTRACT DOCUMENTS AND SHALL HAVE NO BEARING WHATSOEVER ON THE INTERPRETATION OF THE STANDARD SPECIFICATIONS, THE STANDARD PLANS, THE SPECIAL PROVISIONS, NOR SHALL THEY HAVE ANY BEARING WHATSOEVER ON THE INTERPRETATION OF THE OTHER PUBLICATIONS REFERENCED THEREIN.

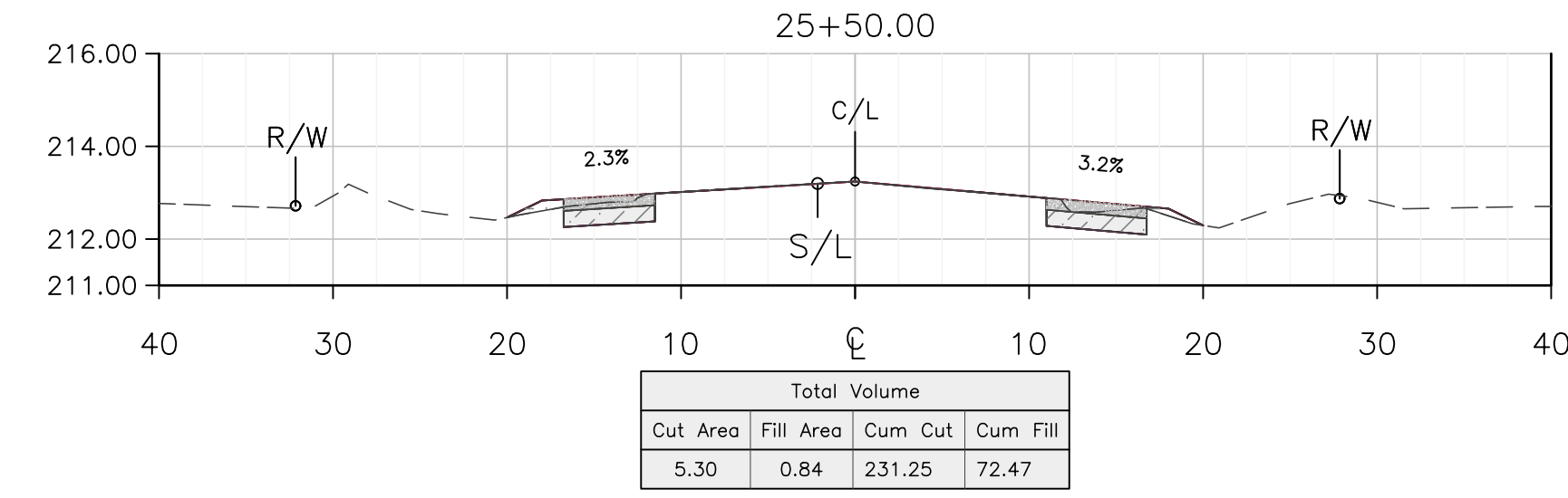
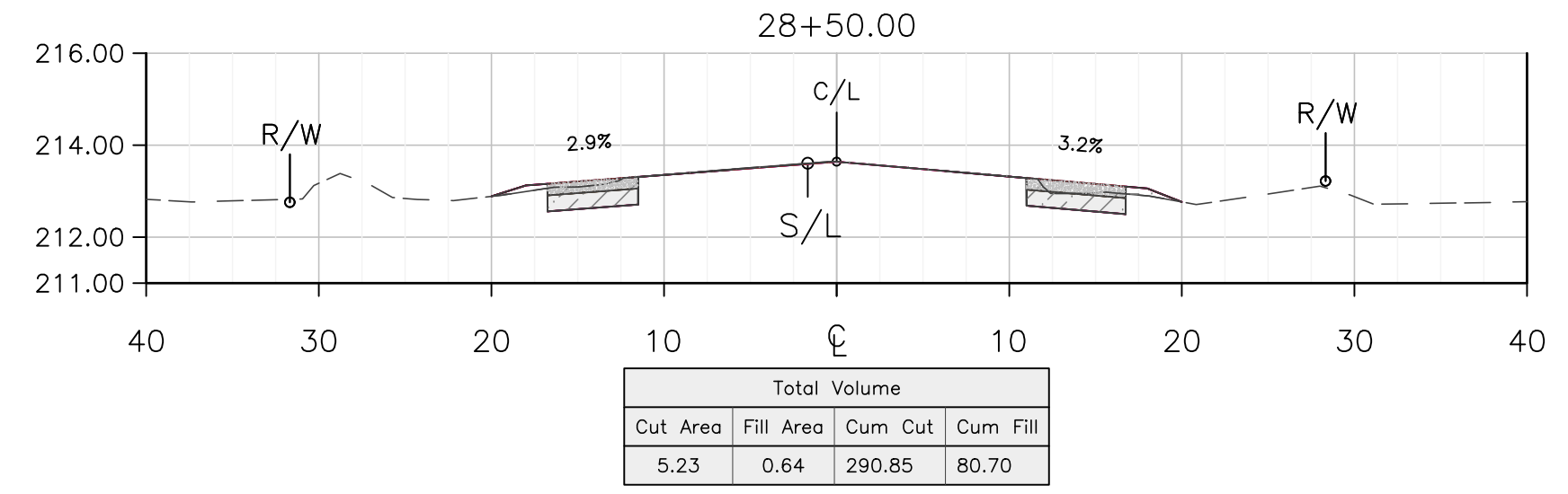
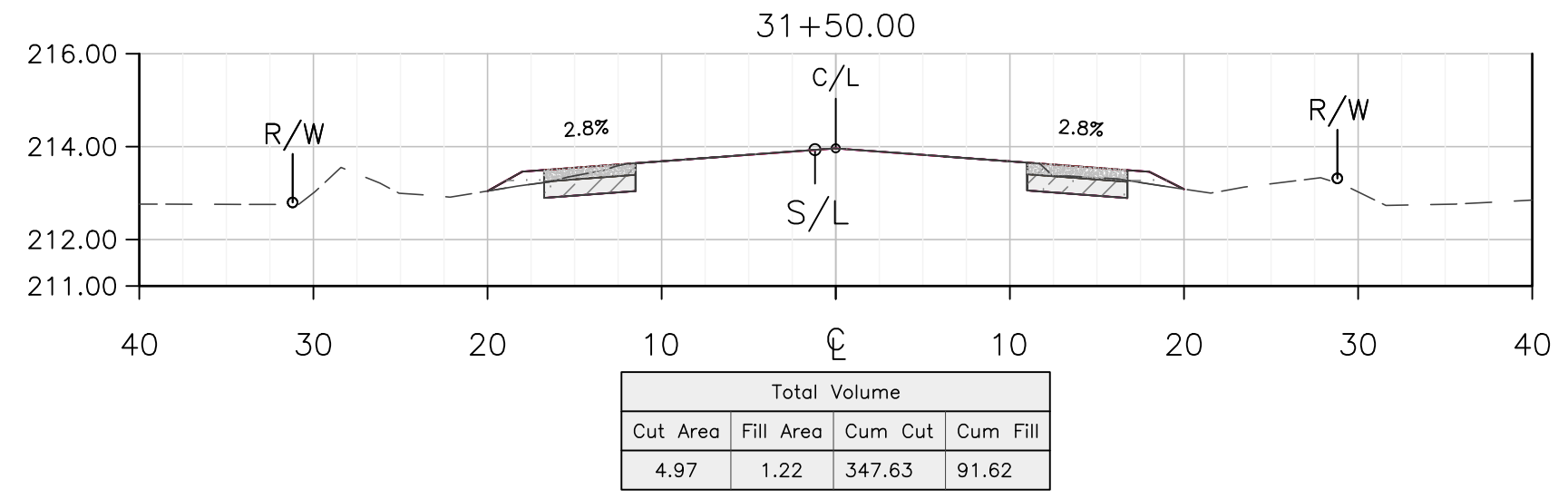
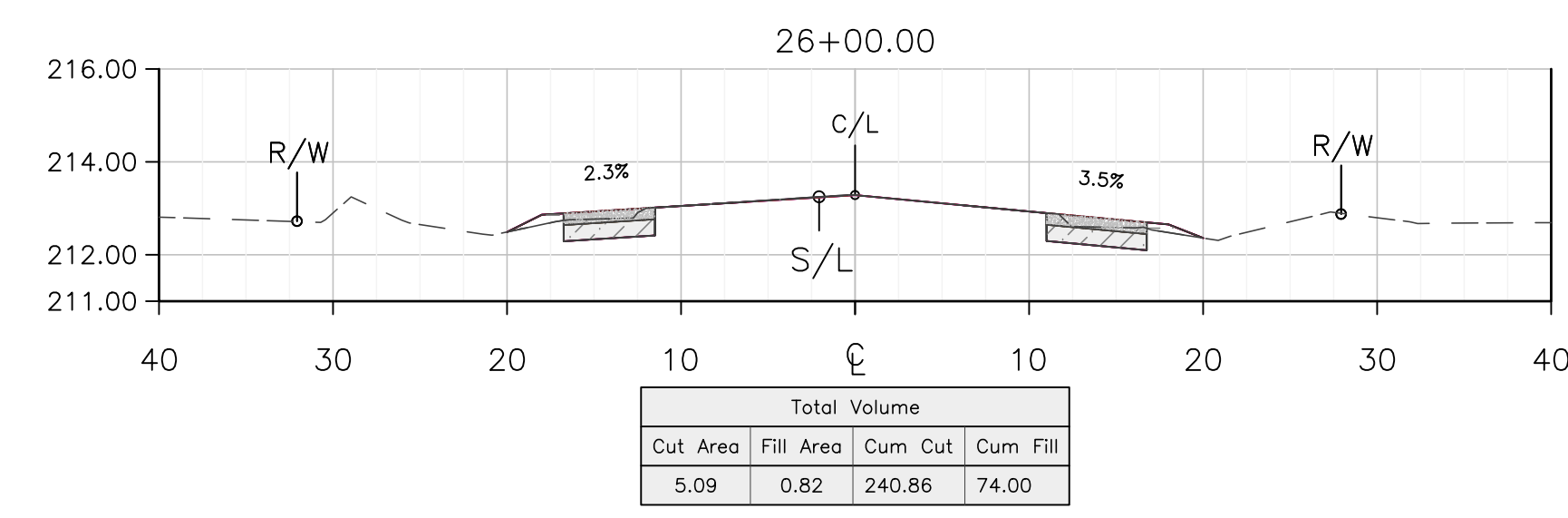
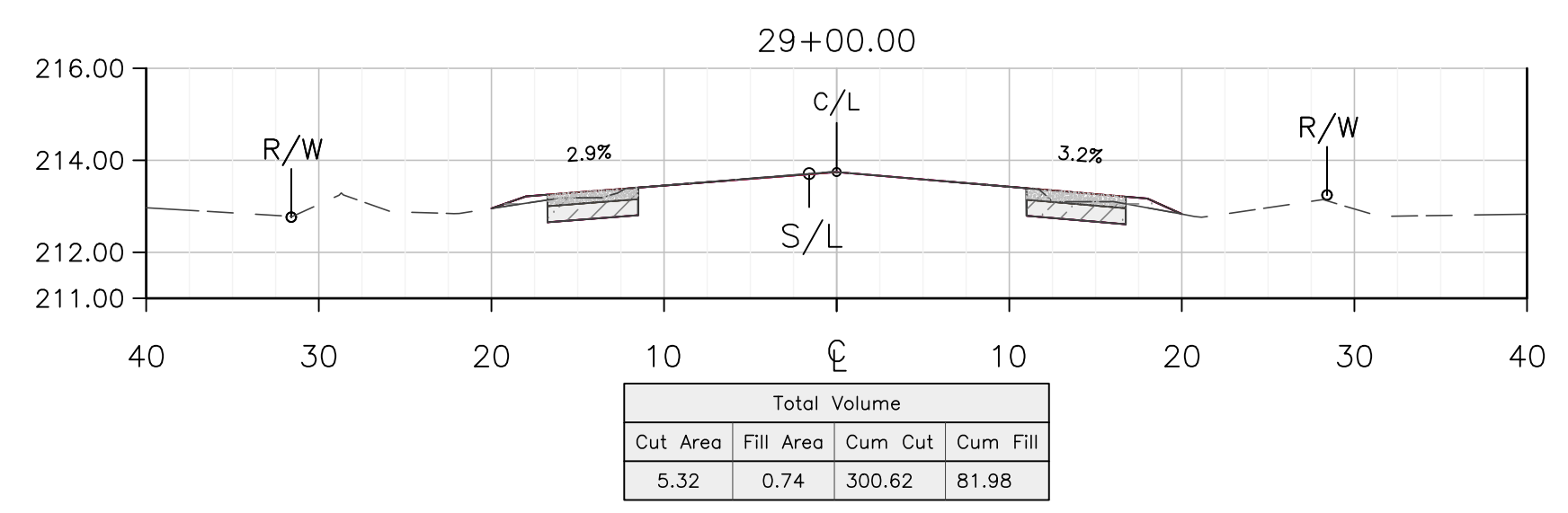
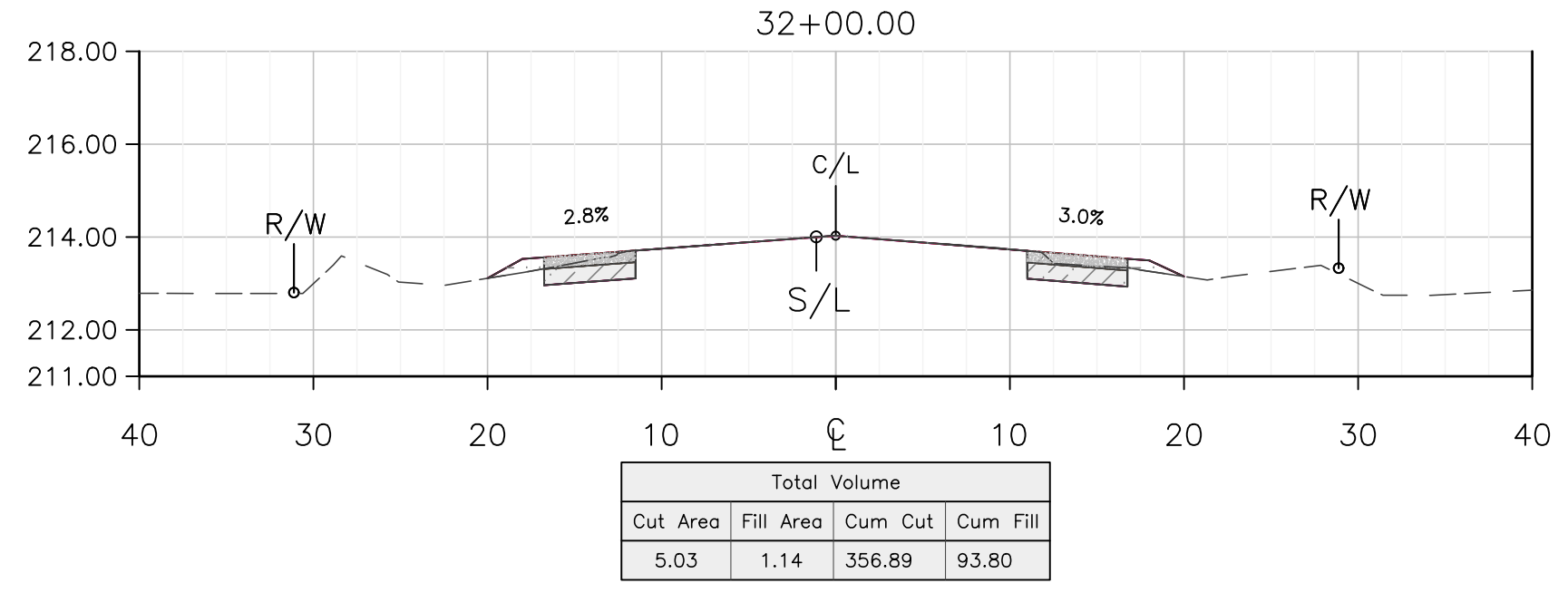
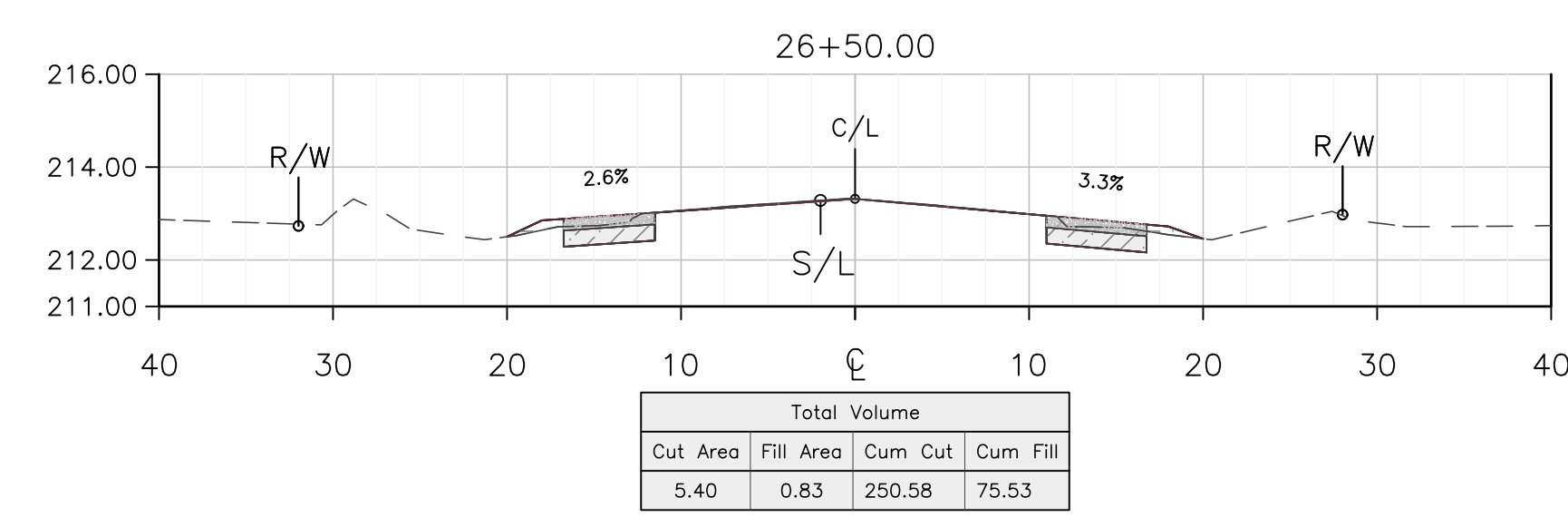
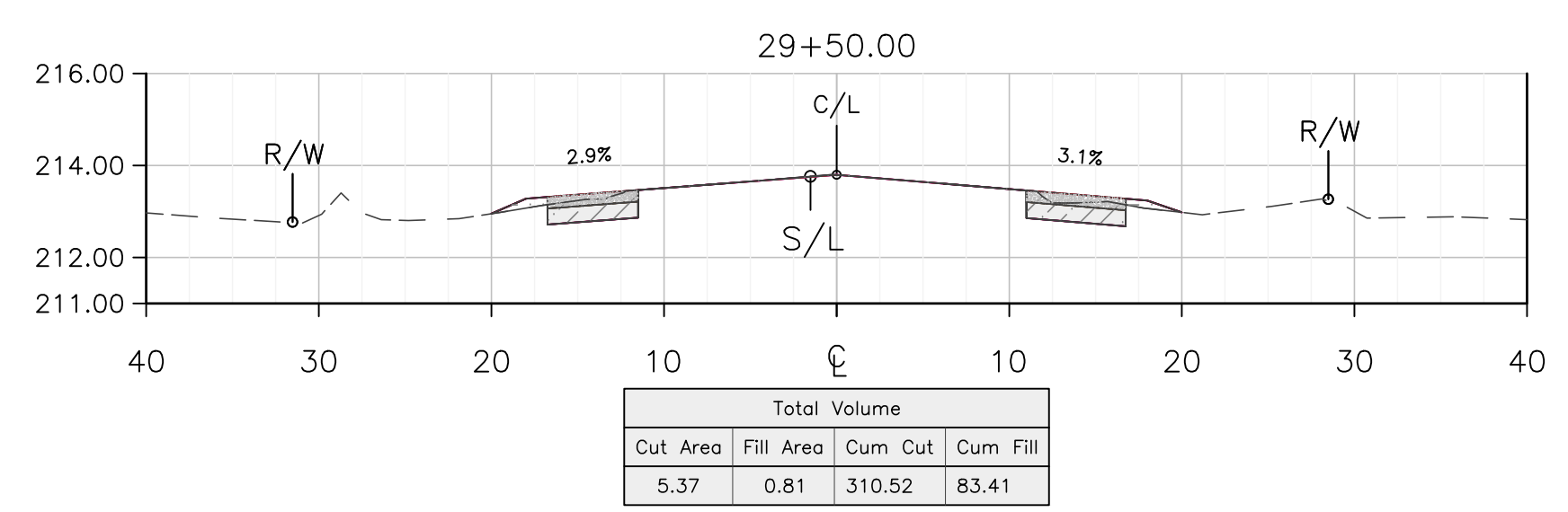
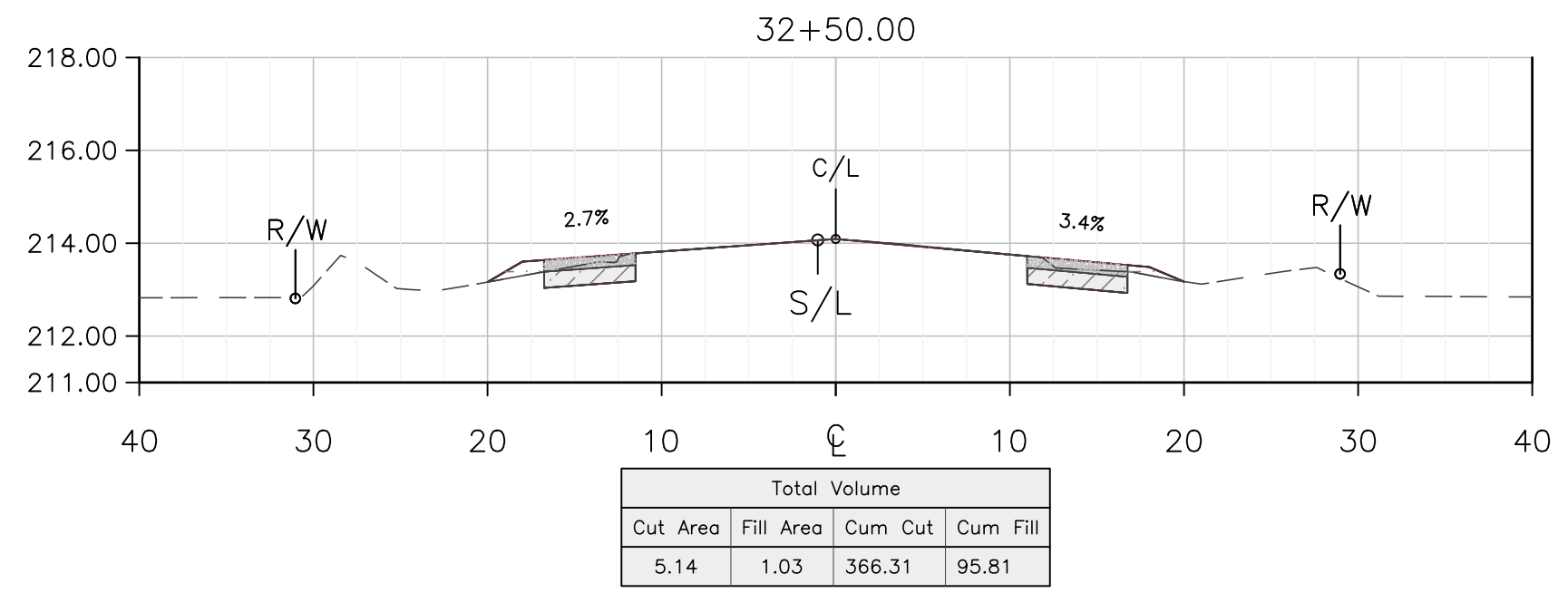
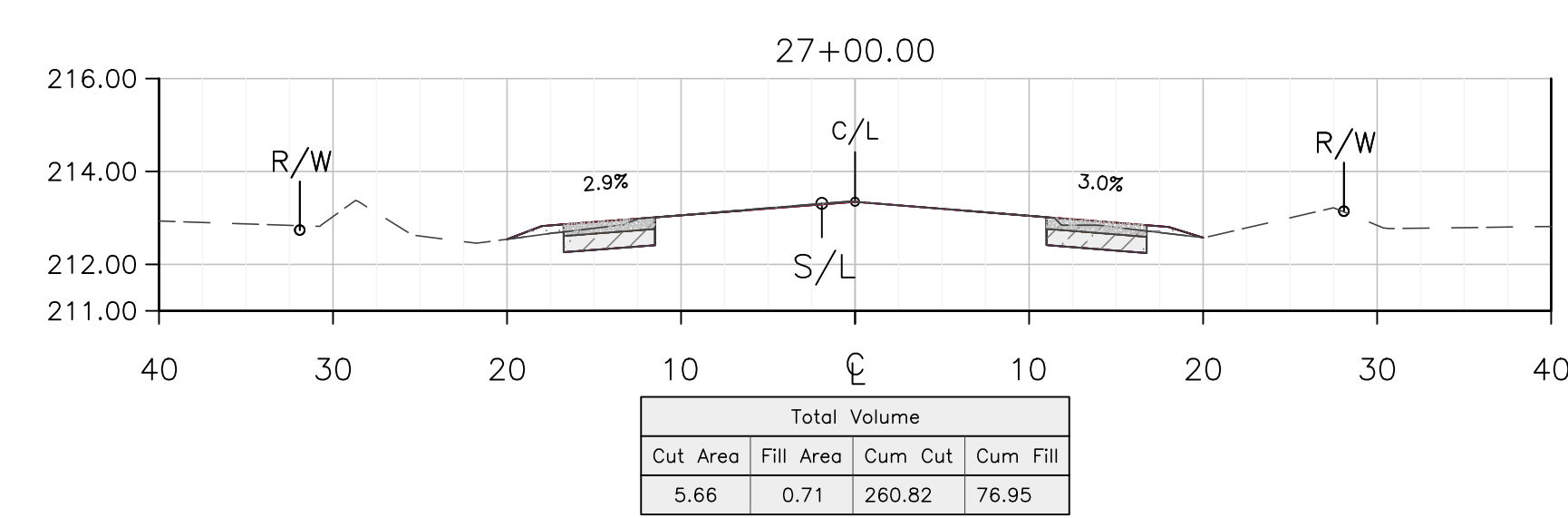
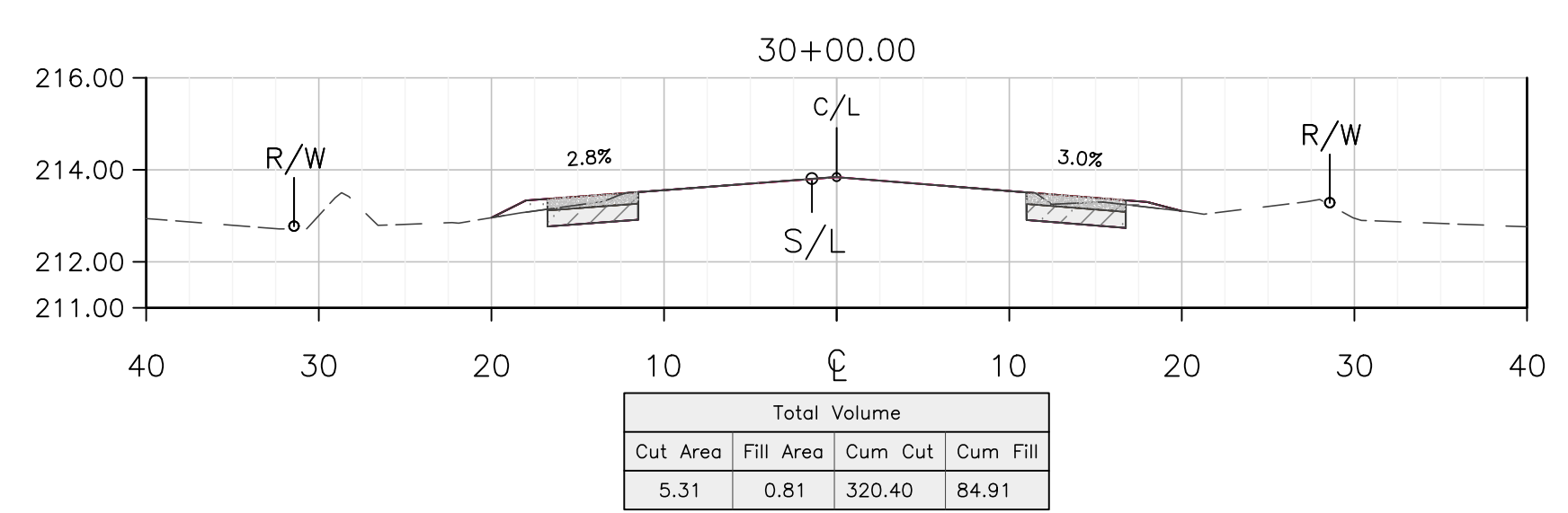
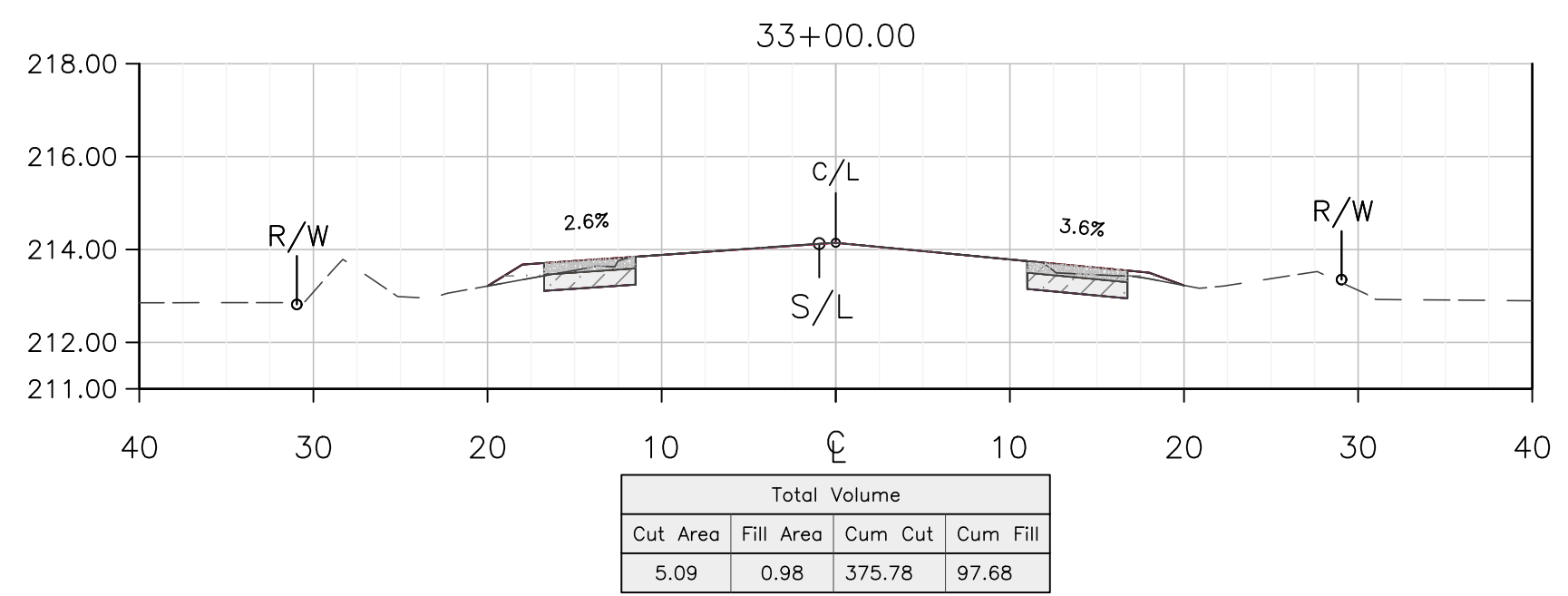
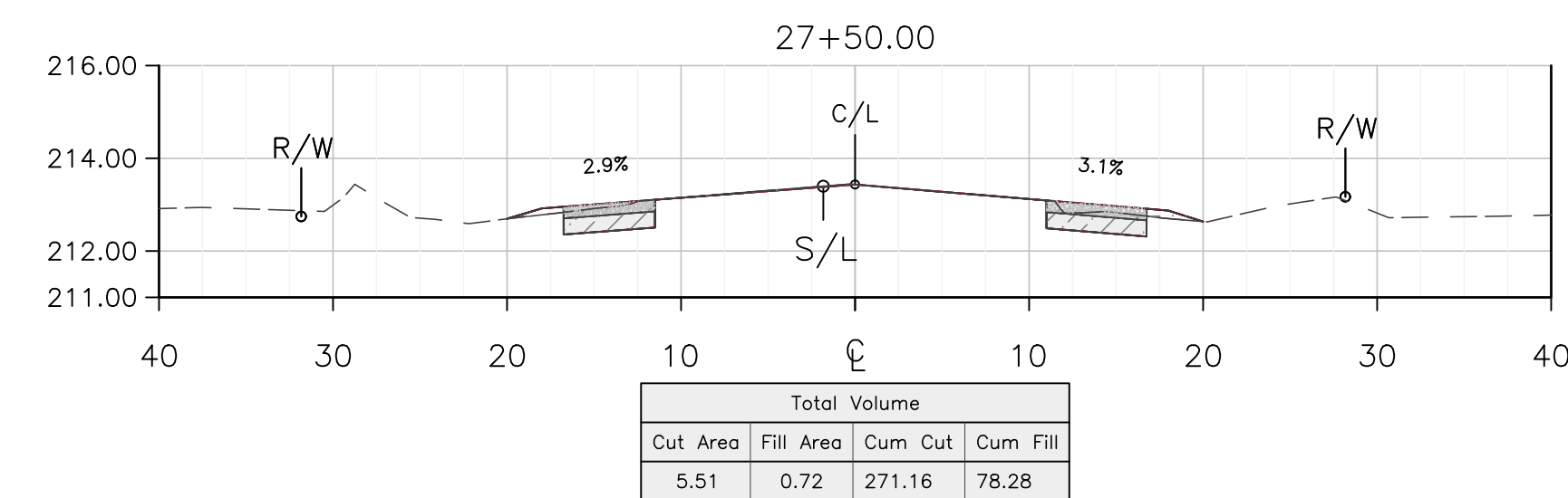
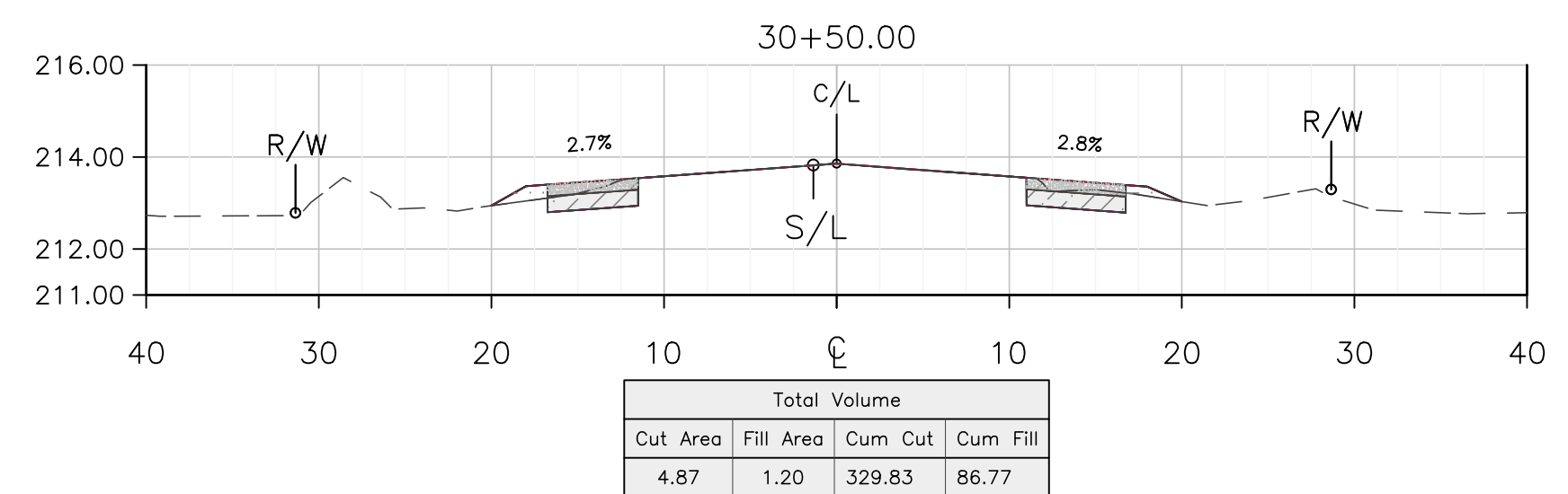
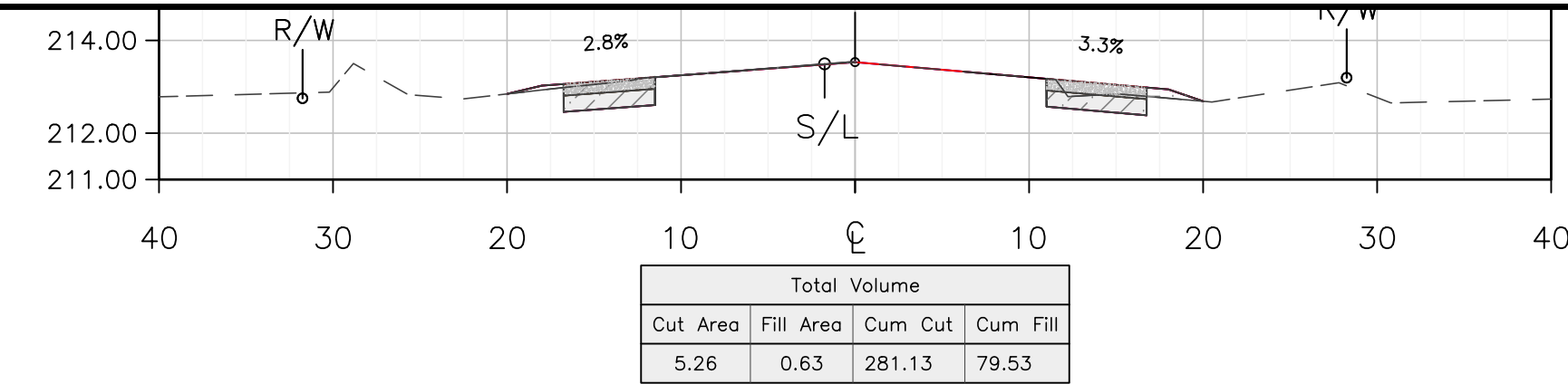
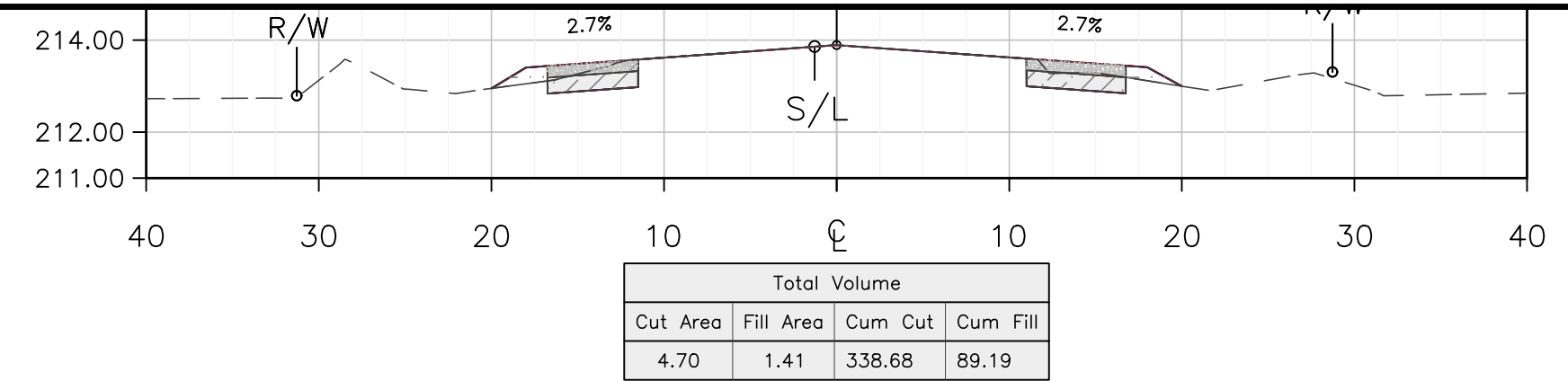

THESE CROSS SECTIONS ARE FOR THE CONTRACTOR'S INFORMATION ONLY. THEY ARE NOT TO BE CONSIDERED TO BE PART OF THE CONTRACT DOCUMENTS AND SHALL HAVE NO BEARING WHATSOEVER ON THE INTERPRETATION OF THE STANDARD SPECIFICATIONS, THE STANDARD PLANS, THE SPECIAL PROVISIONS, NOR SHALL THEY HAVE ANY BEARING WHATSOEVER ON THE INTERPRETATION OF THE OTHER PUBLICATIONS REFERENCED THEREIN.

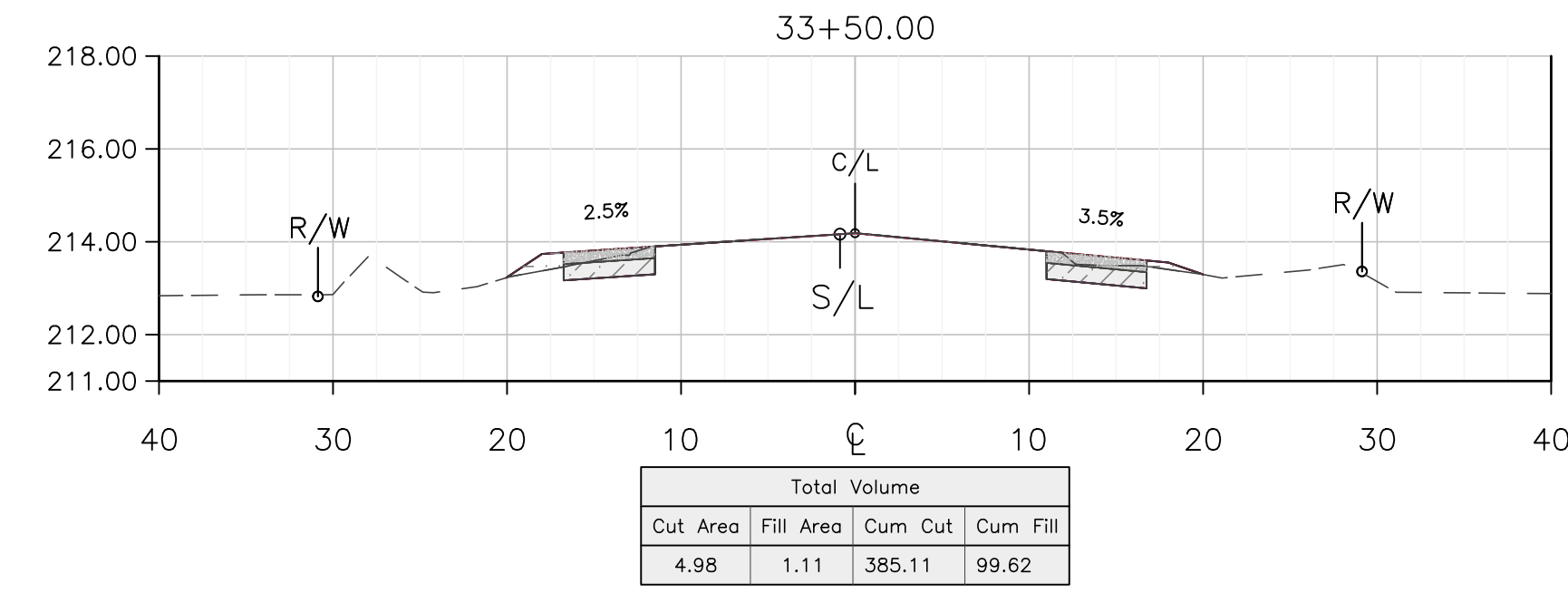
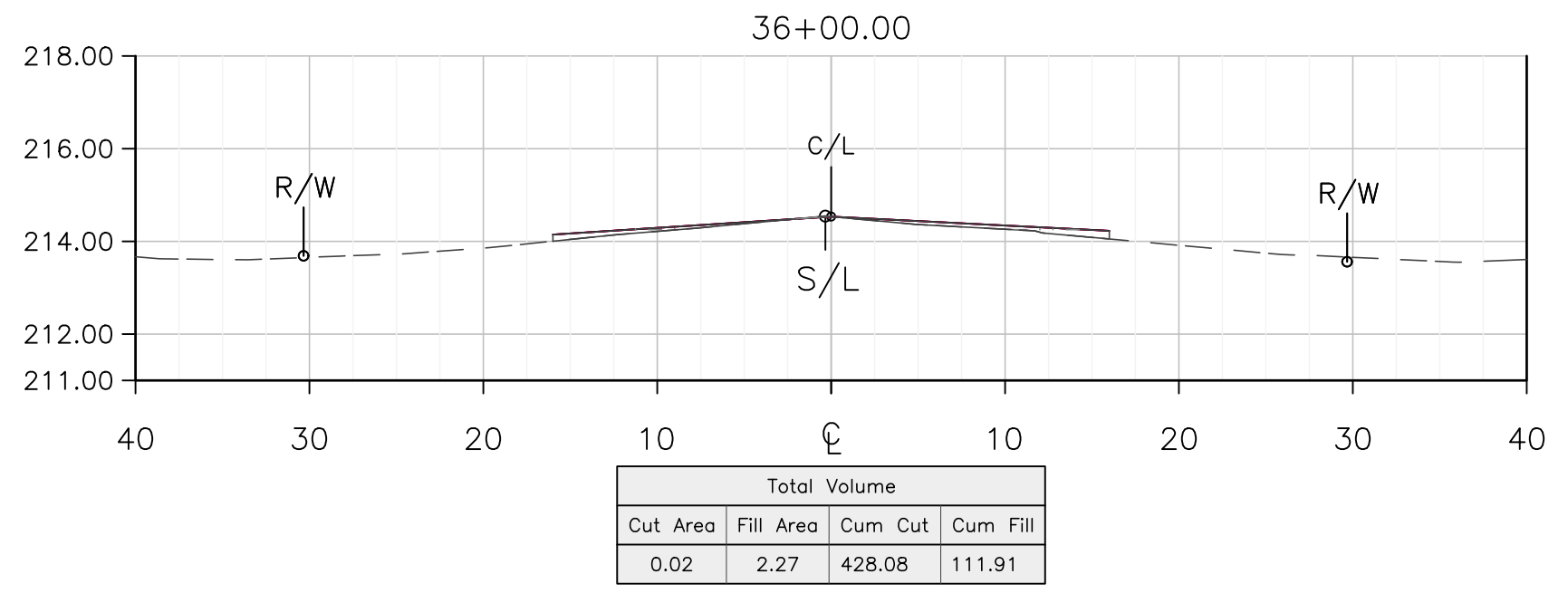
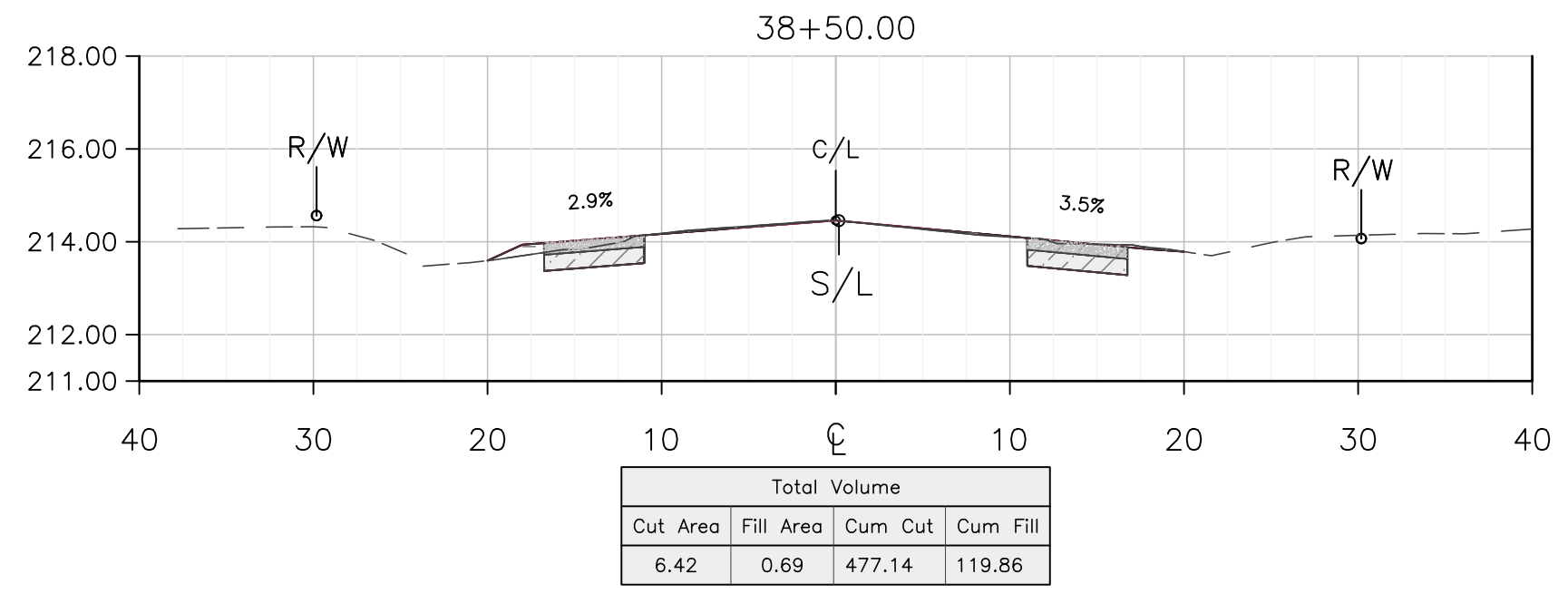
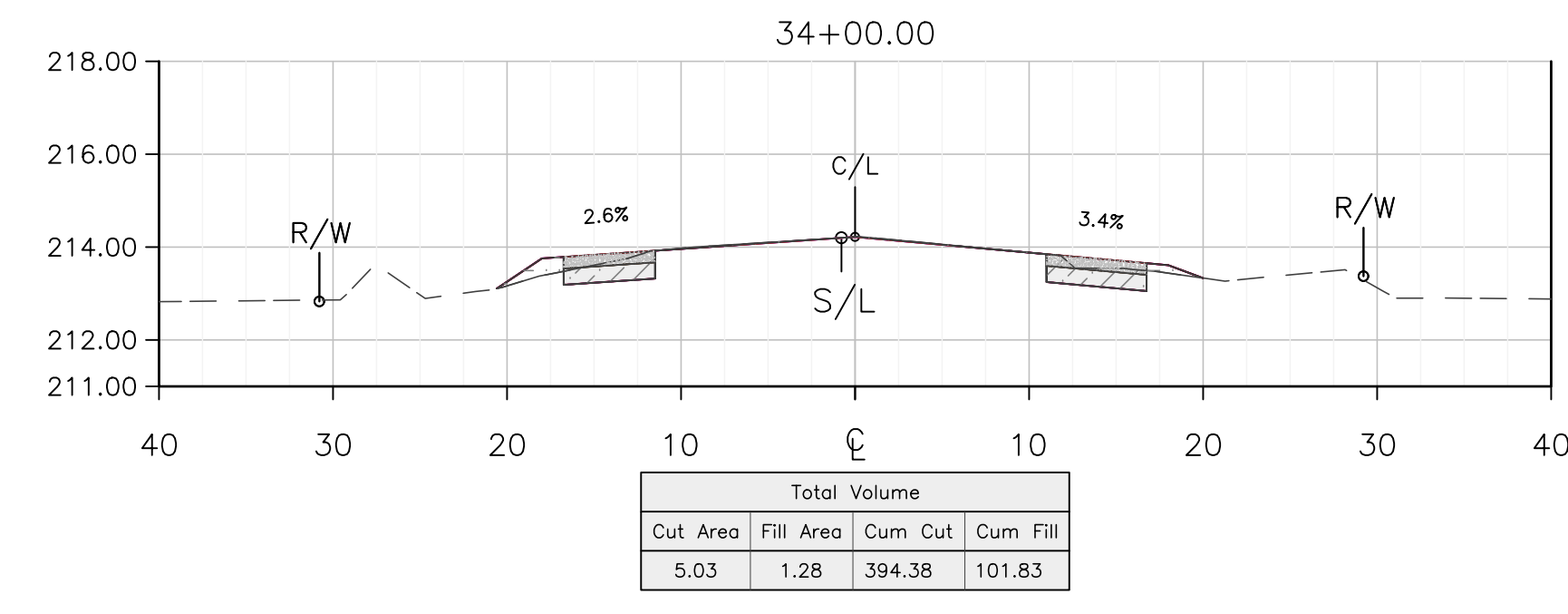
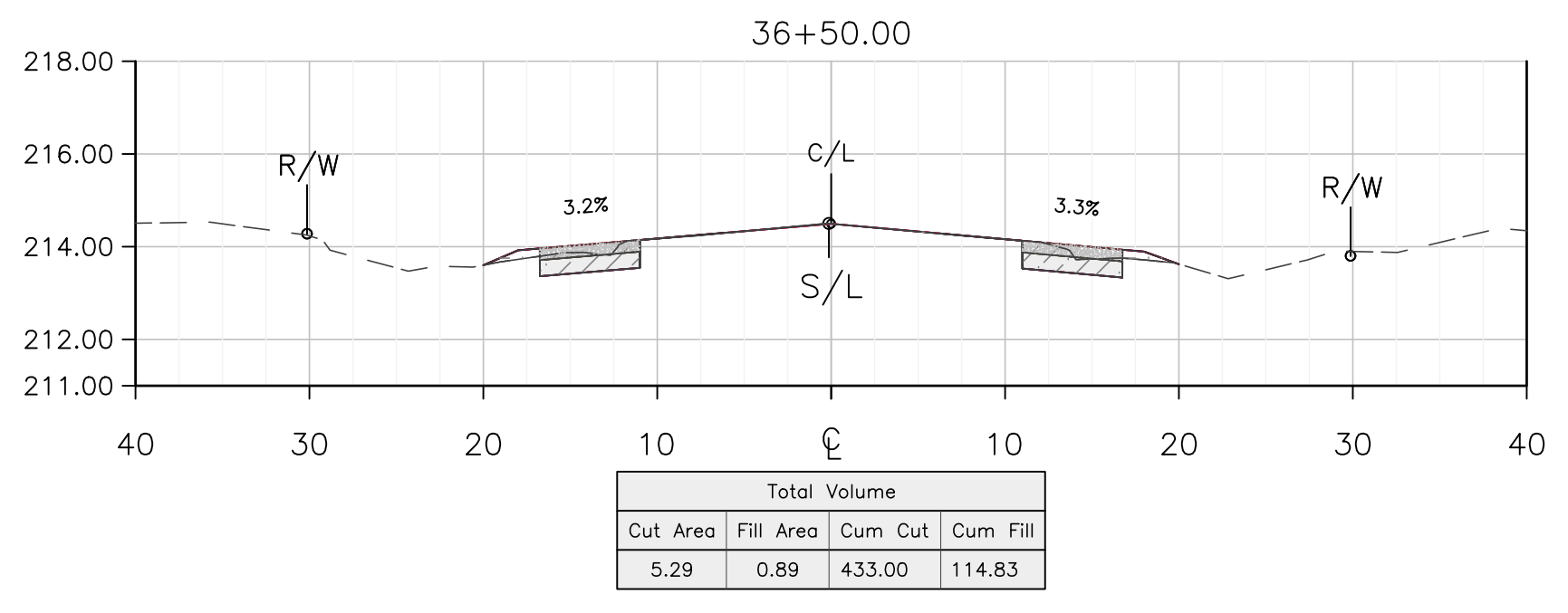
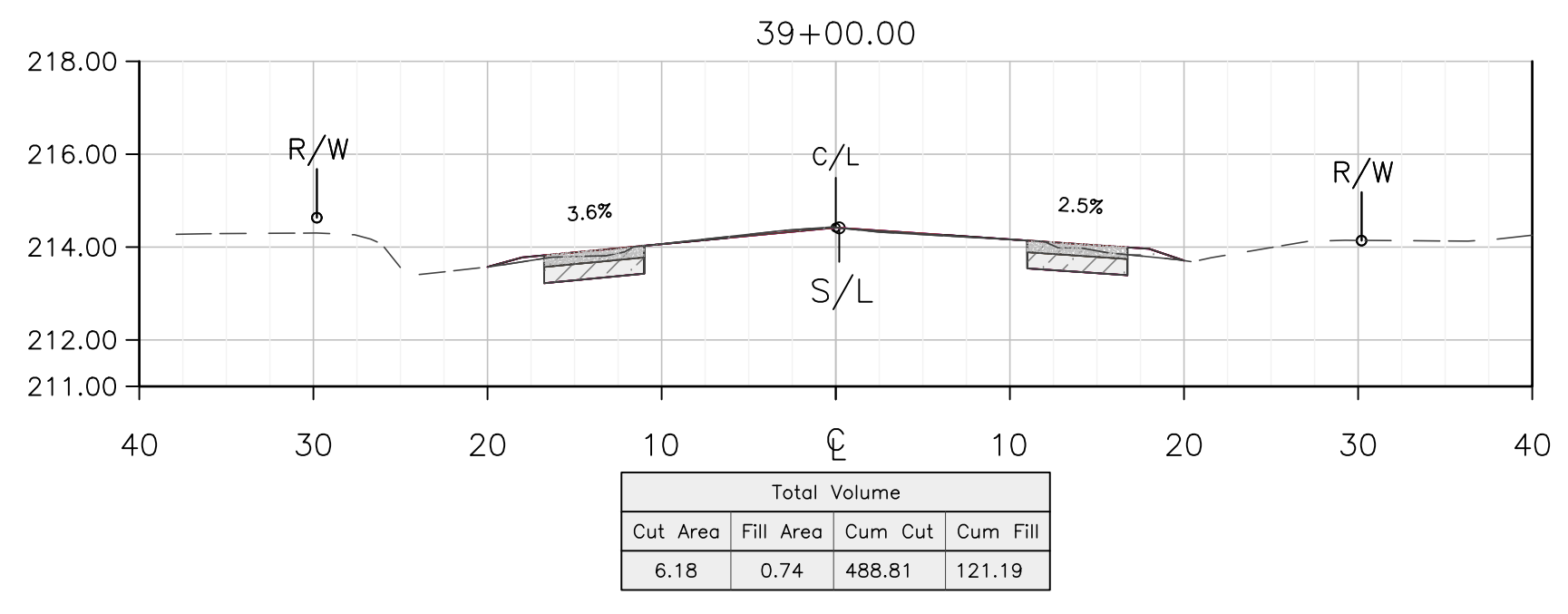
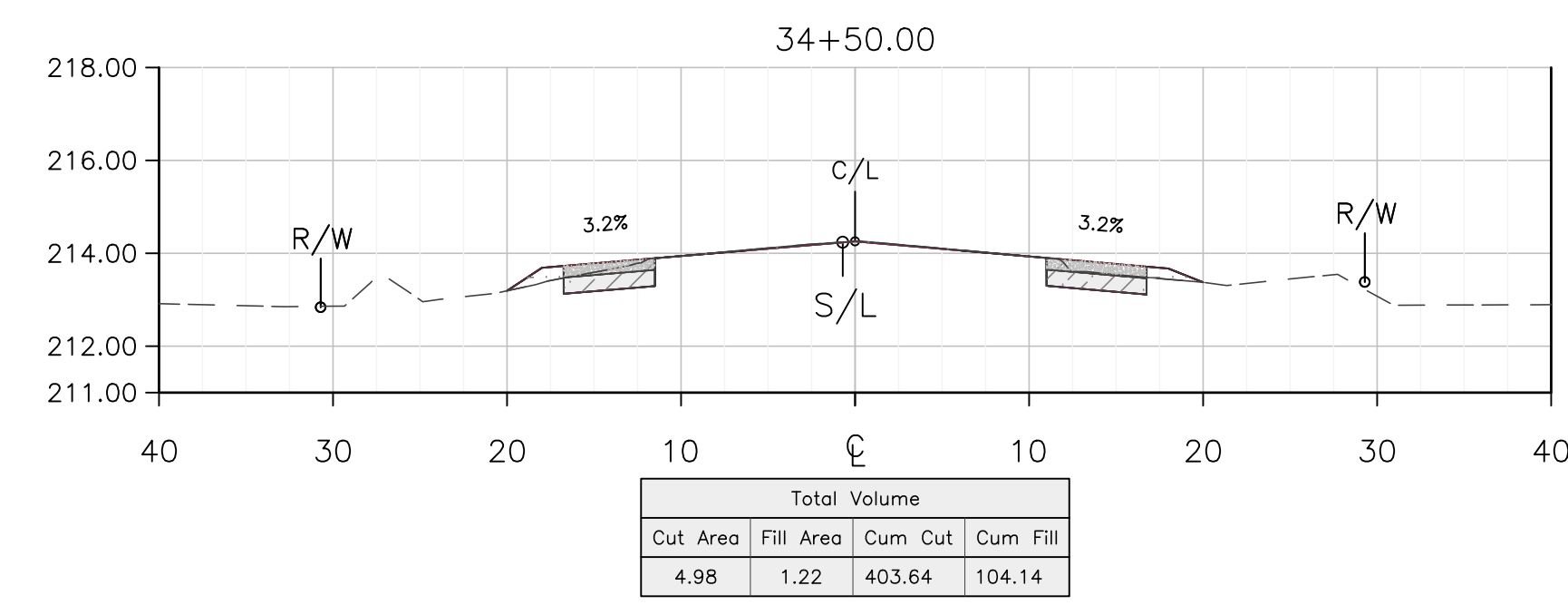
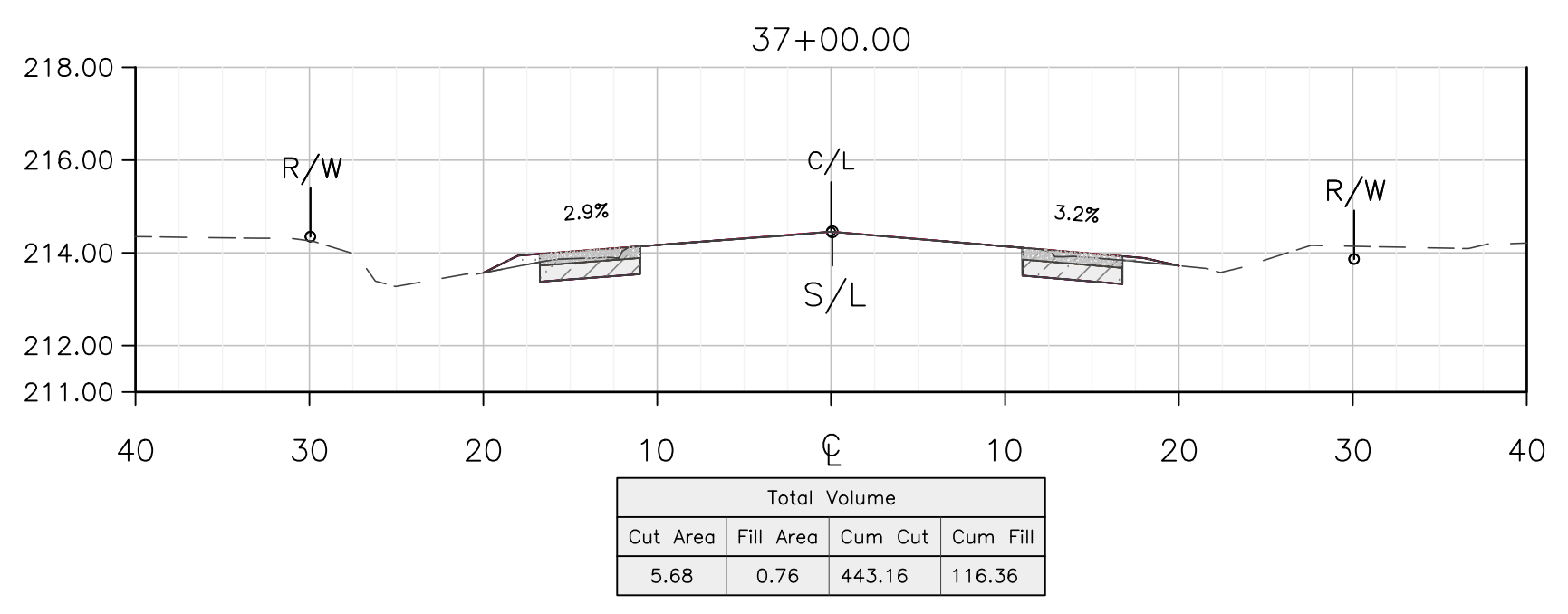
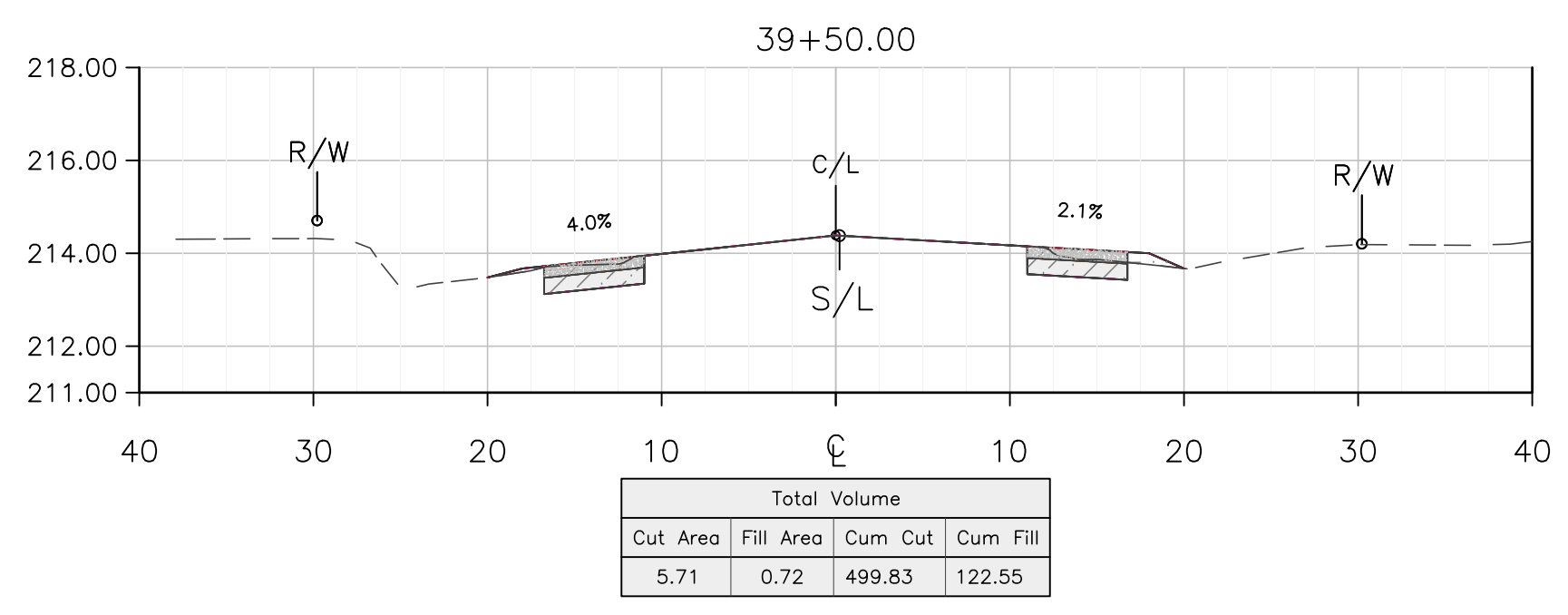
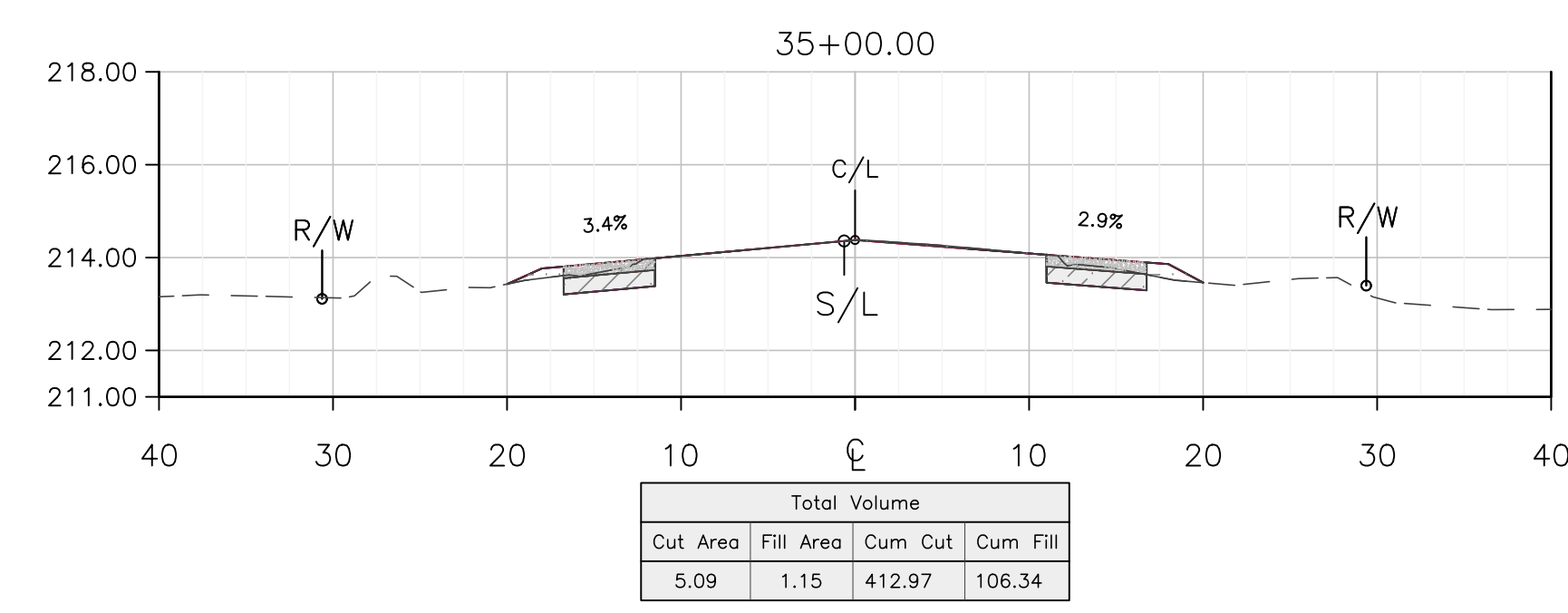
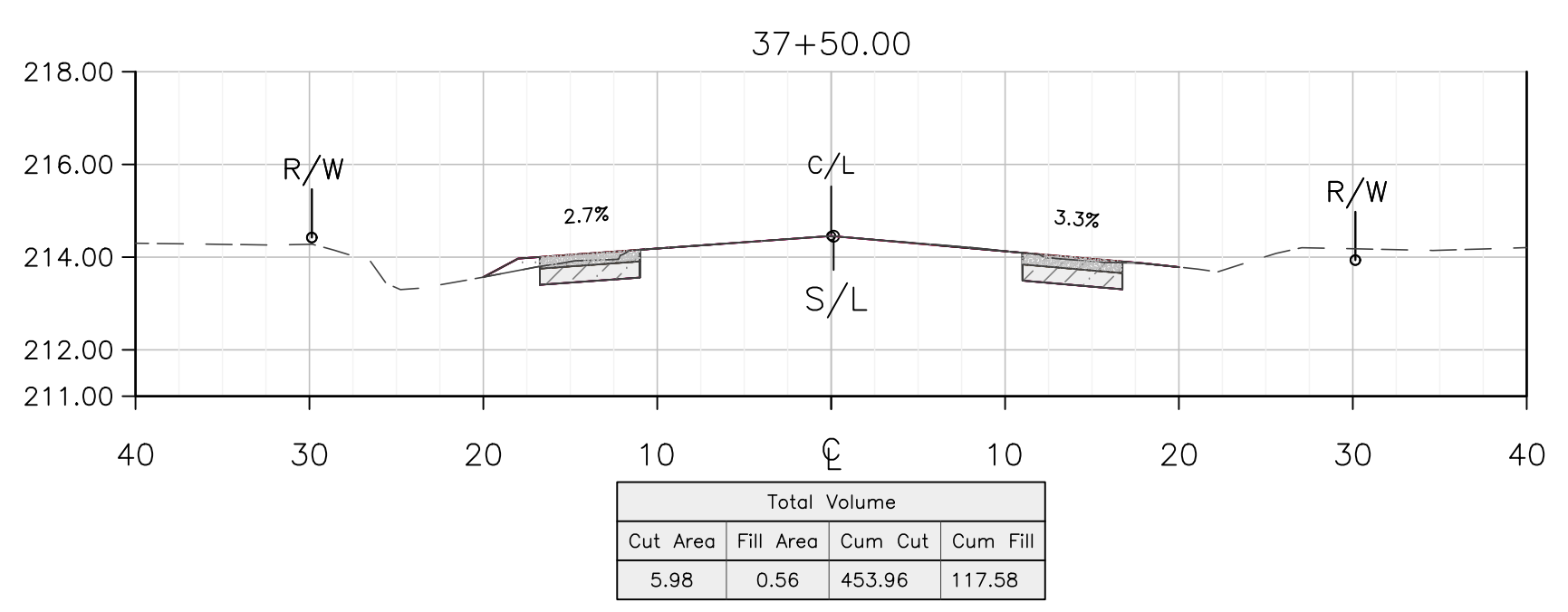
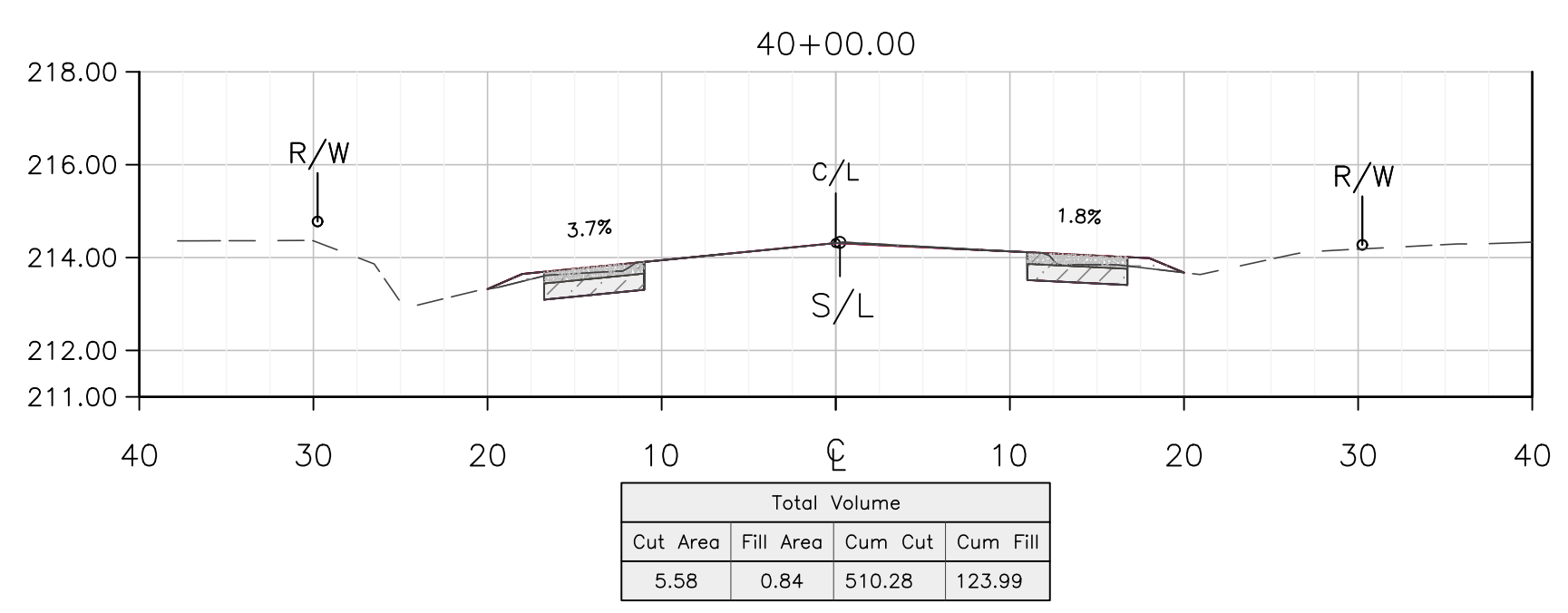
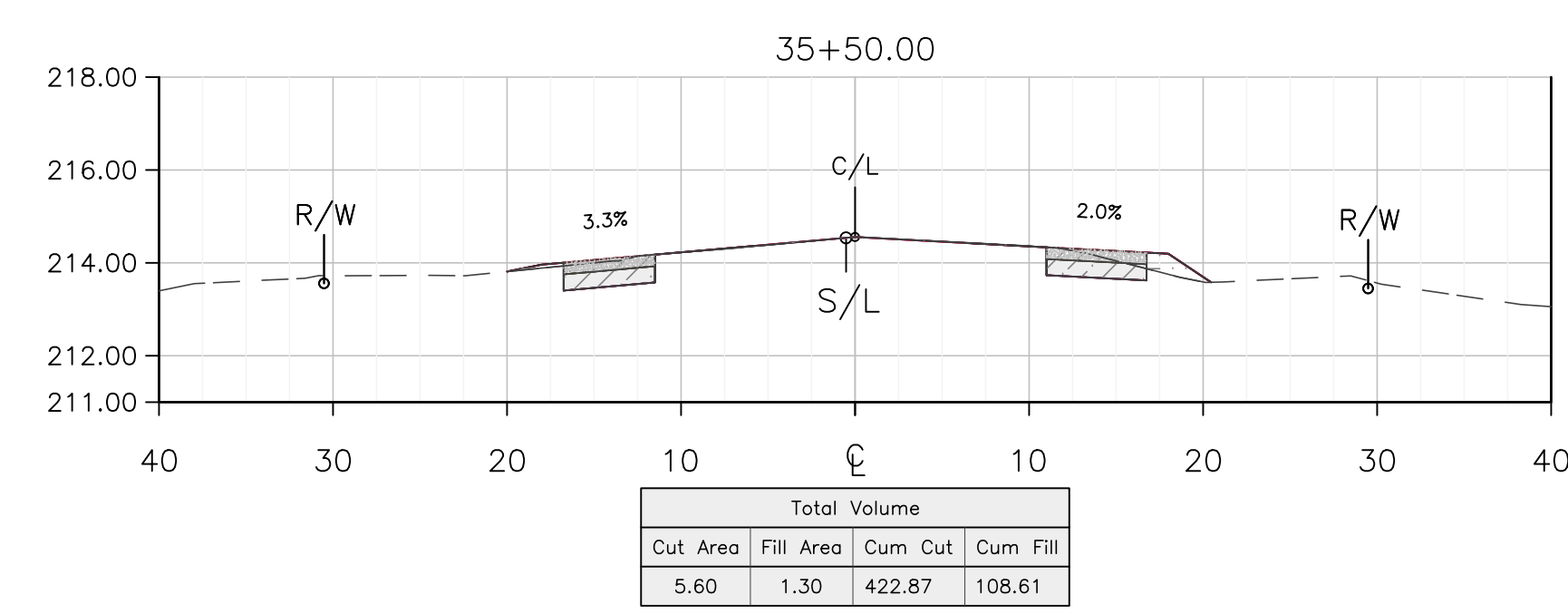
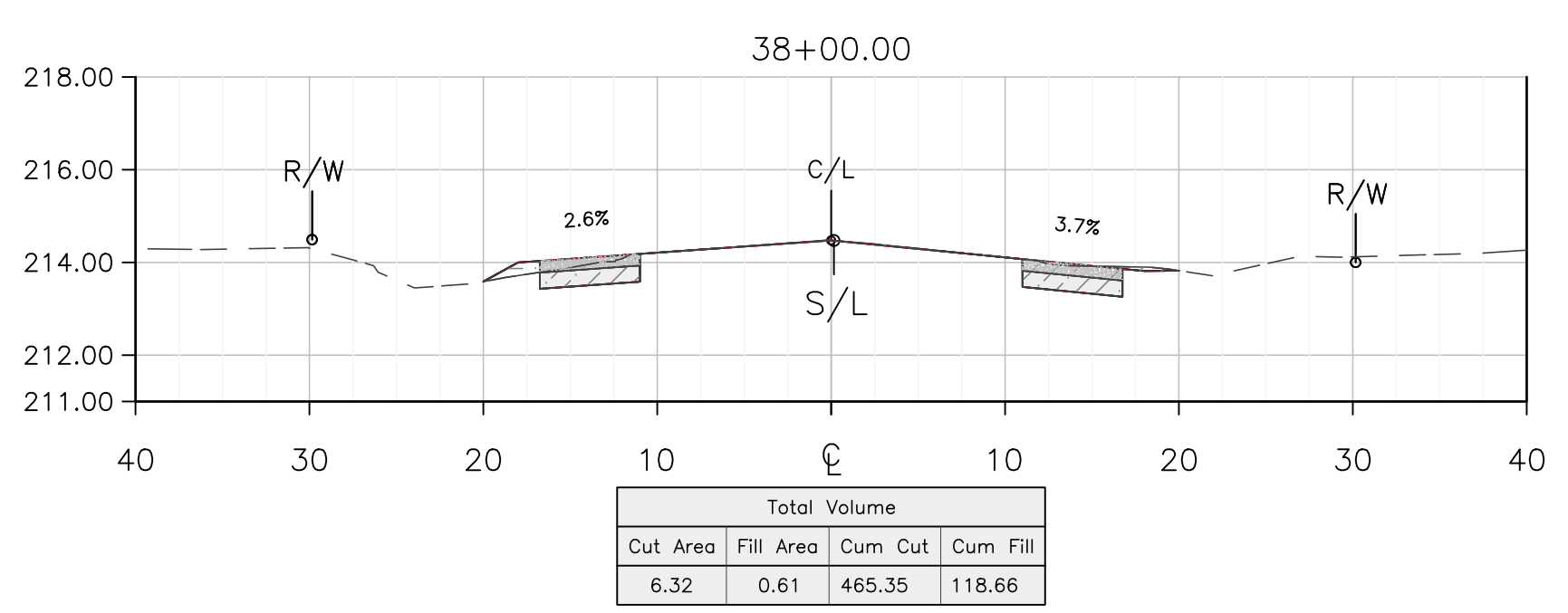
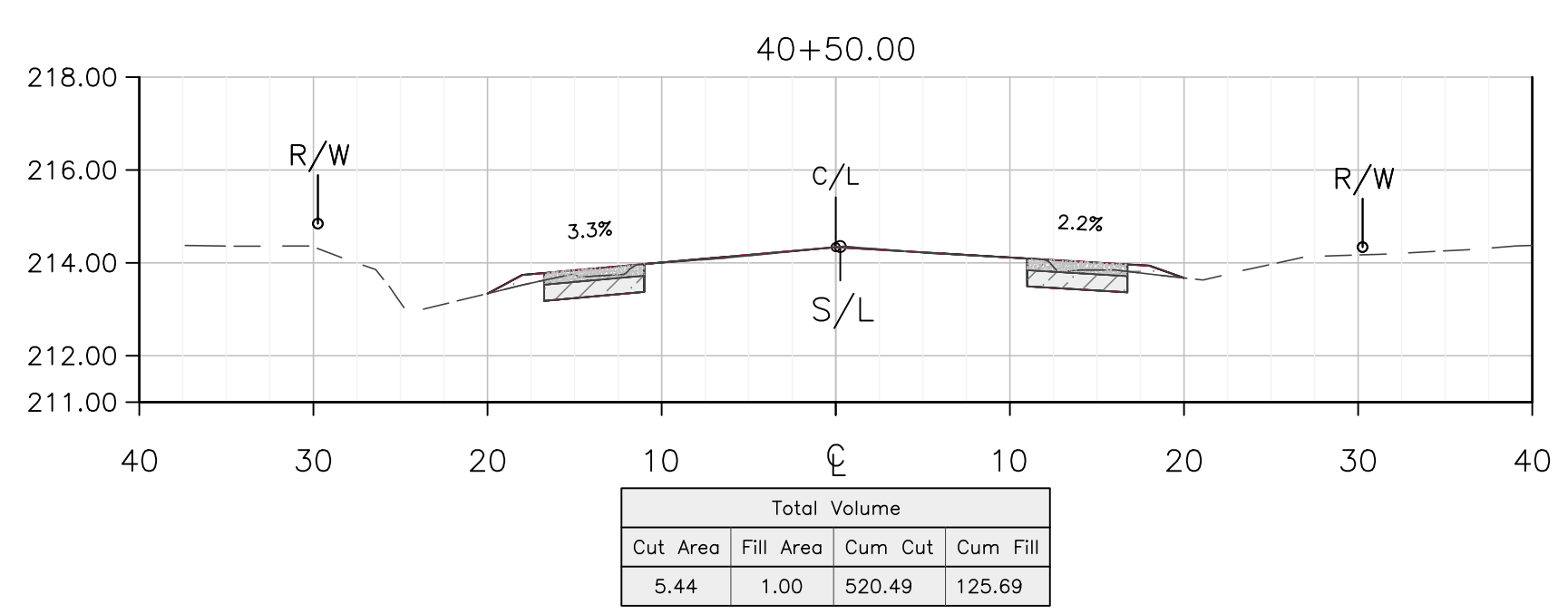

THESE CROSS SECTIONS ARE FOR THE CONTRACTOR'S INFORMATION ONLY. THEY ARE NOT TO BE CONSIDERED TO BE PART OF THE CONTRACT DOCUMENTS AND SHALL HAVE NO BEARING WHATSOEVER ON THE INTERPRETATION OF THE STANDARD SPECIFICATIONS, THE STANDARD PLANS, THE SPECIAL PROVISIONS, NOR SHALL THEY HAVE ANY BEARING WHATSOEVER ON THE INTERPRETATION OF THE OTHER PUBLICATIONS REFERENCED THEREIN.

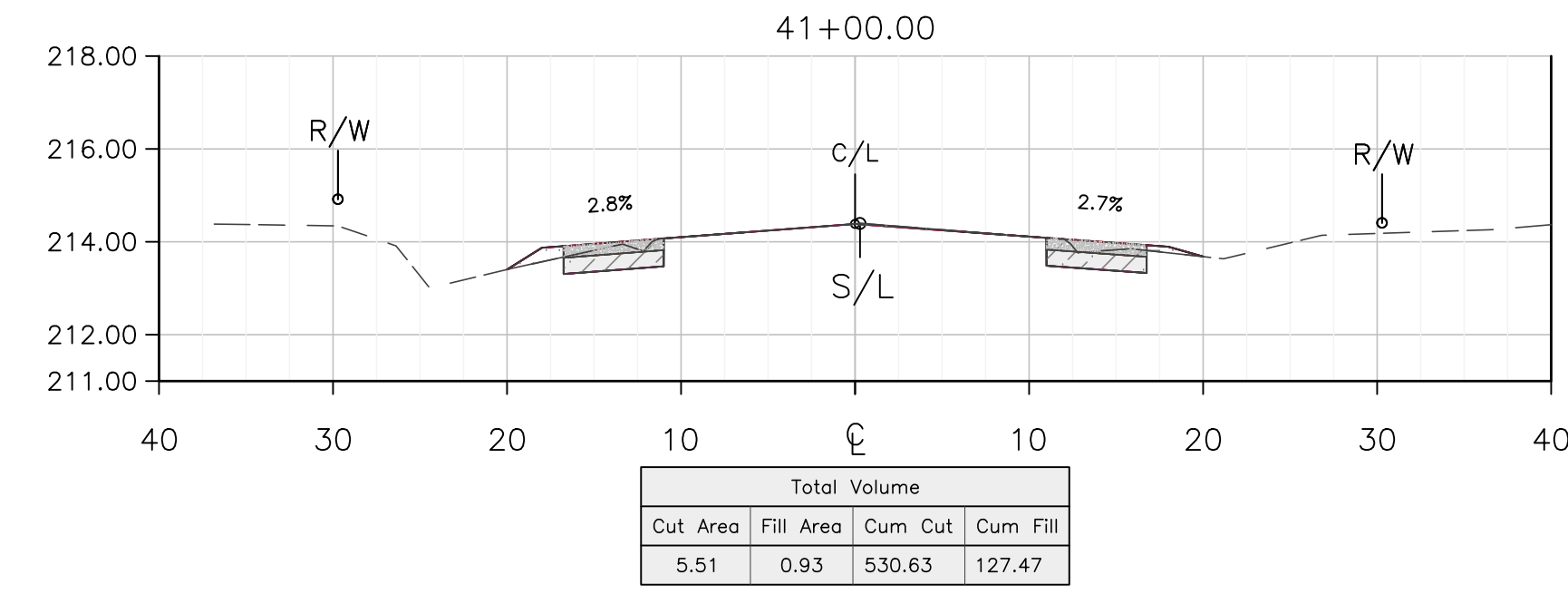
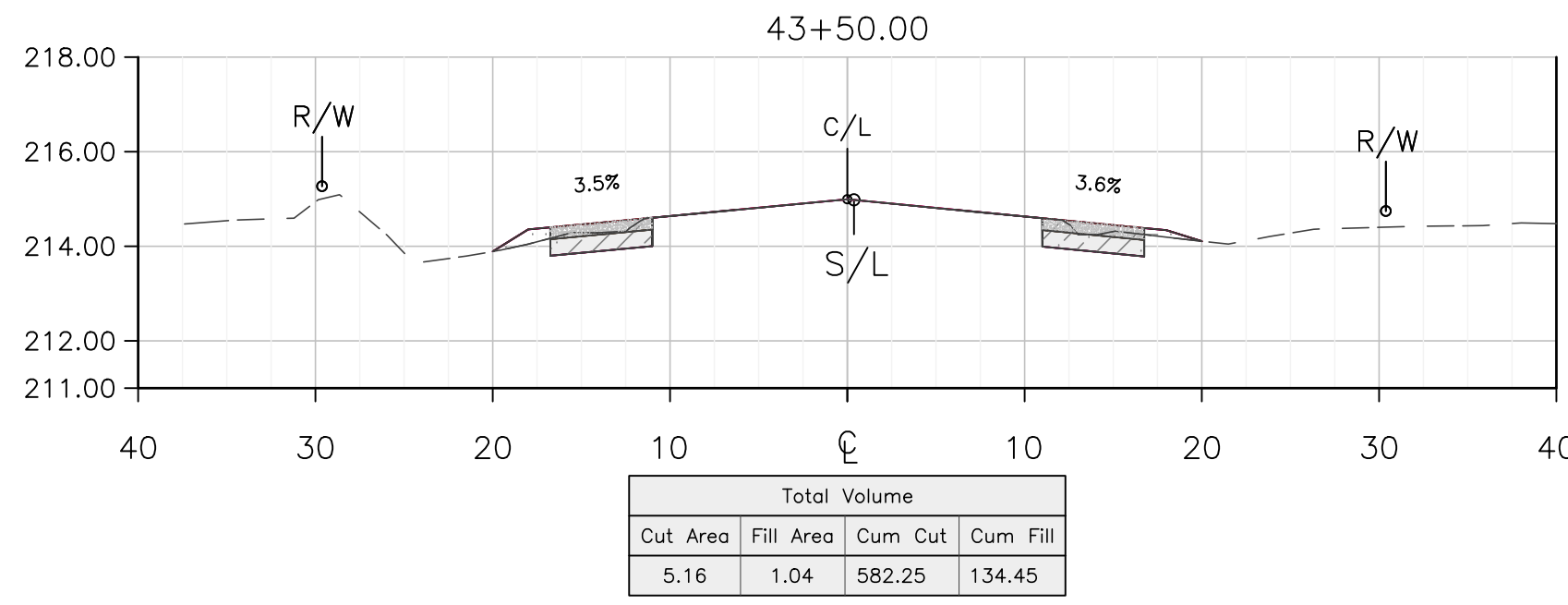
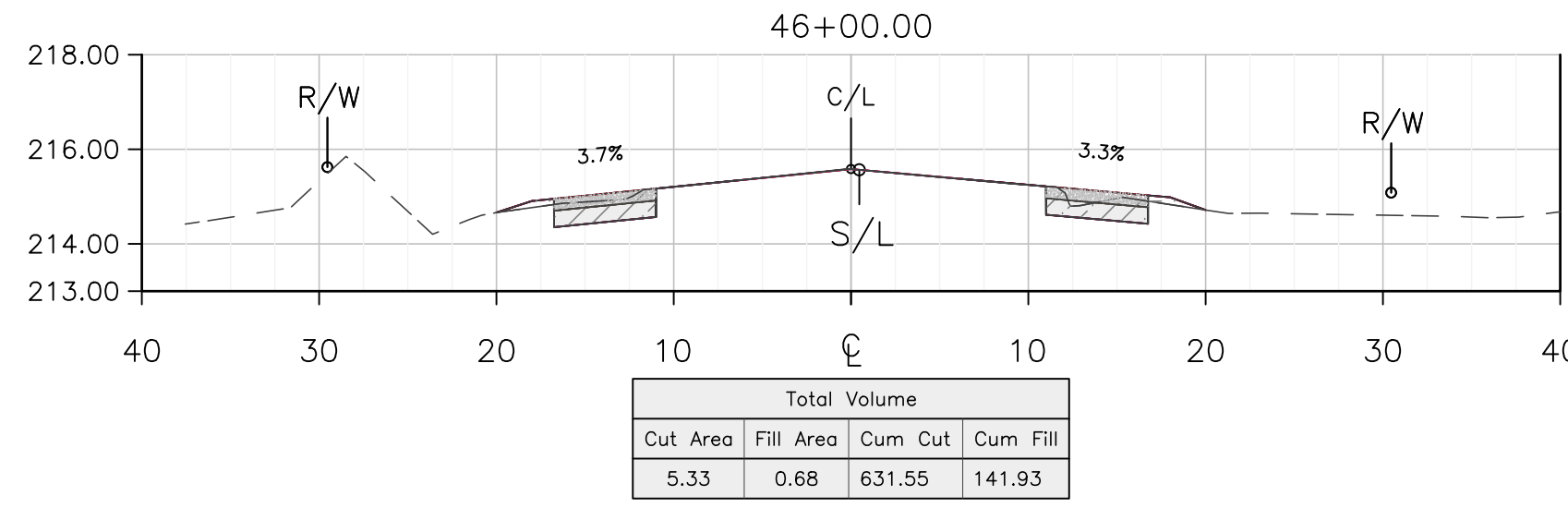
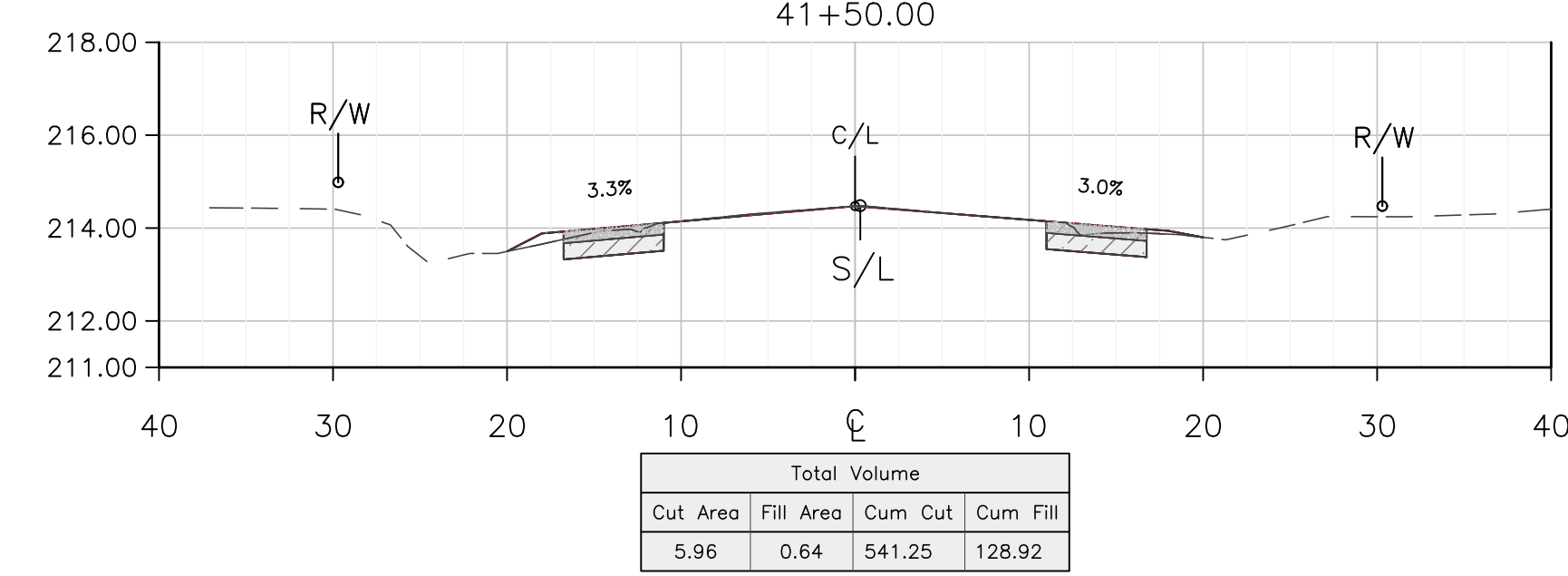
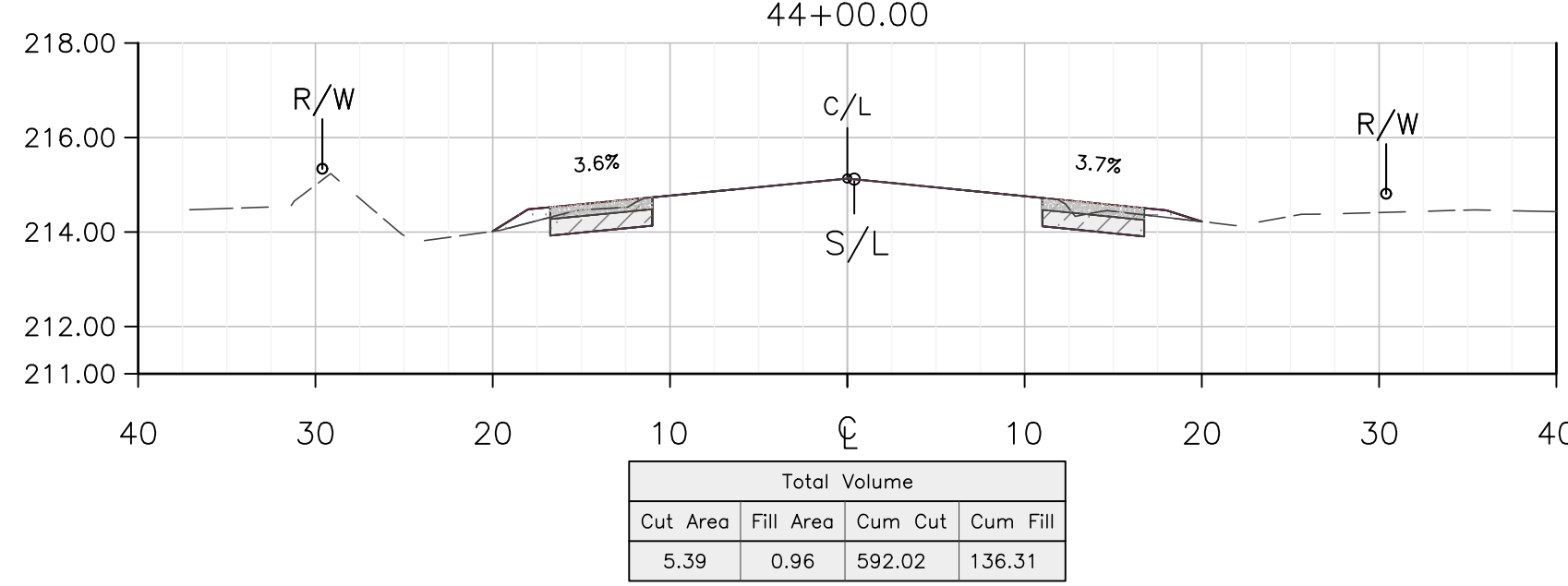
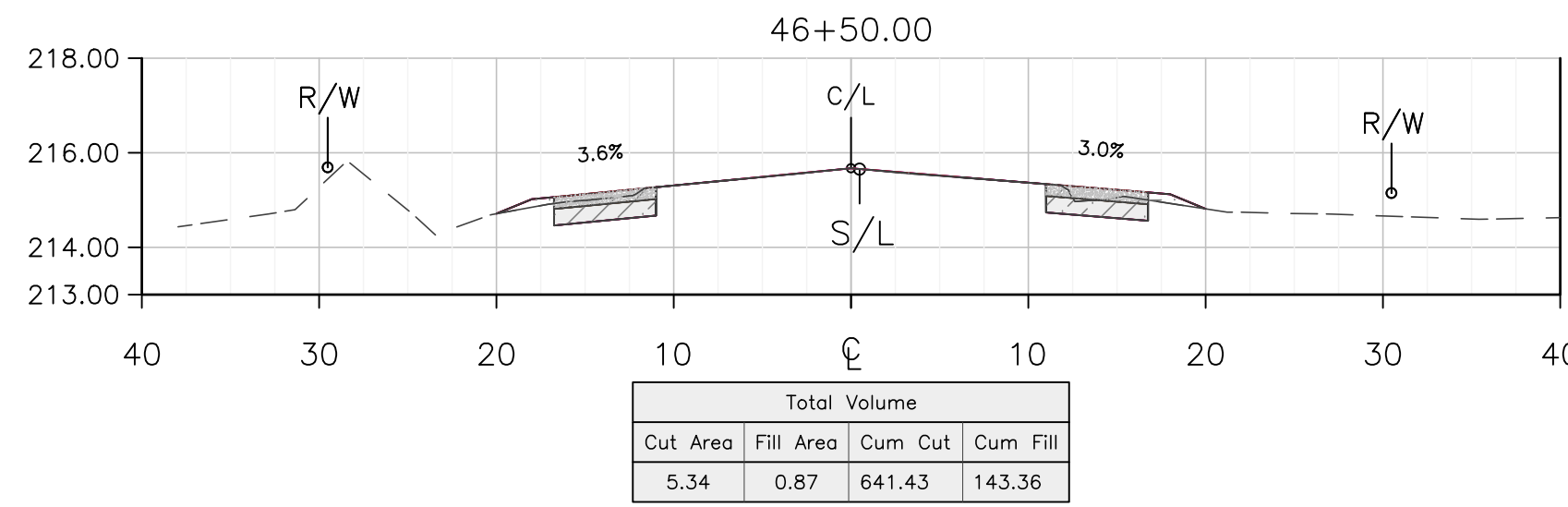
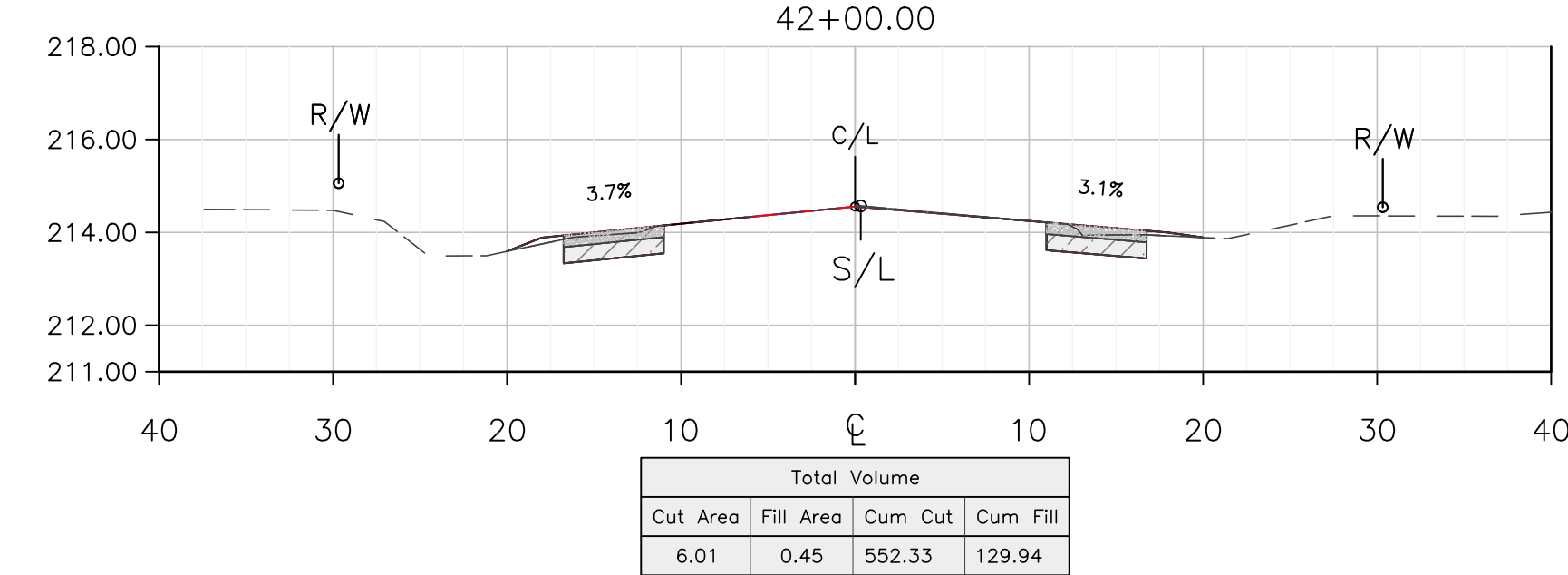
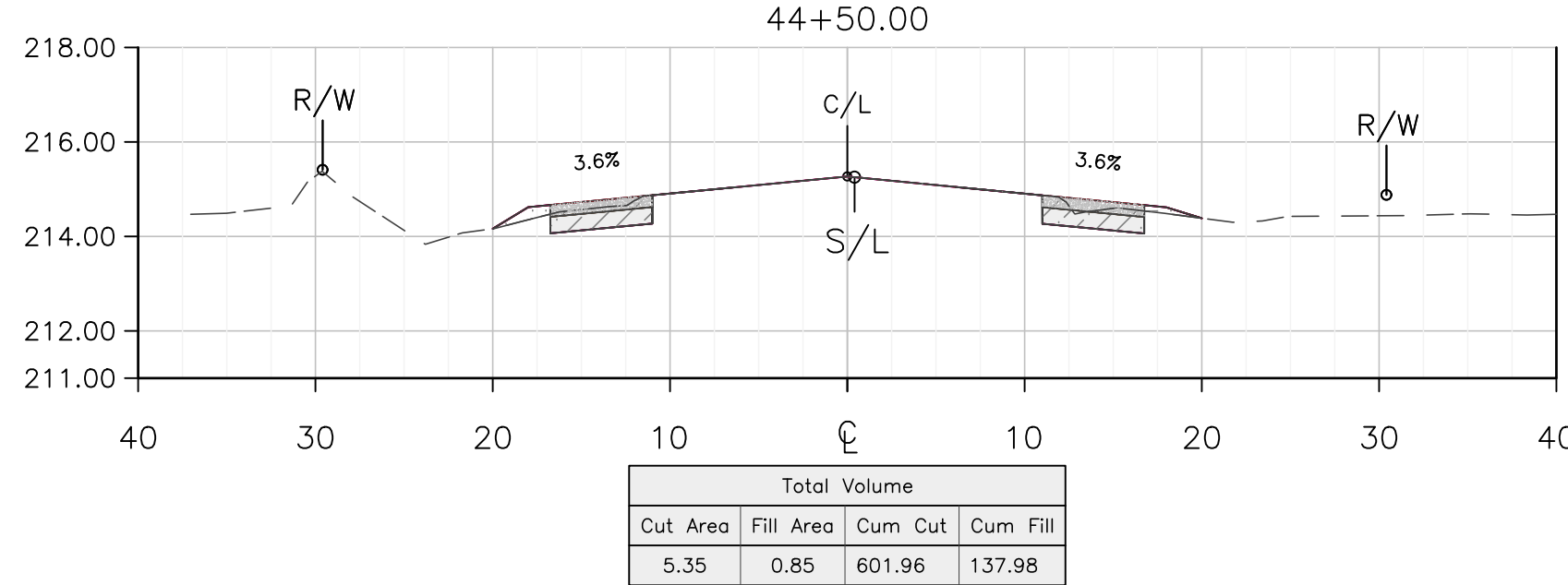
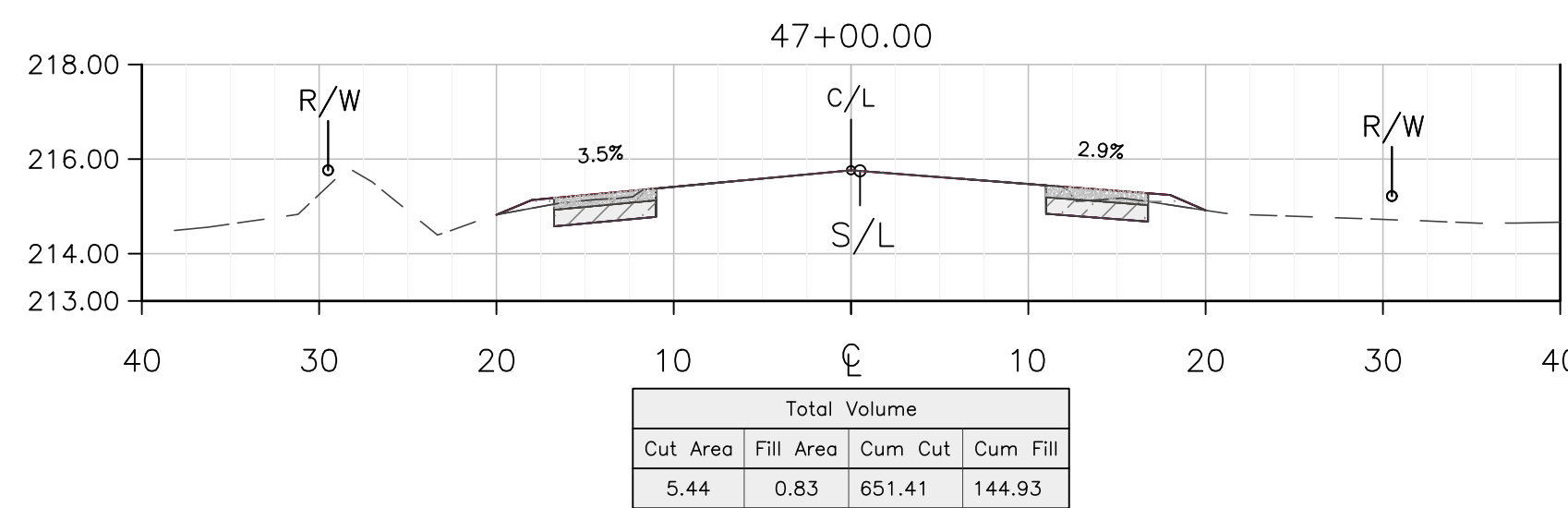
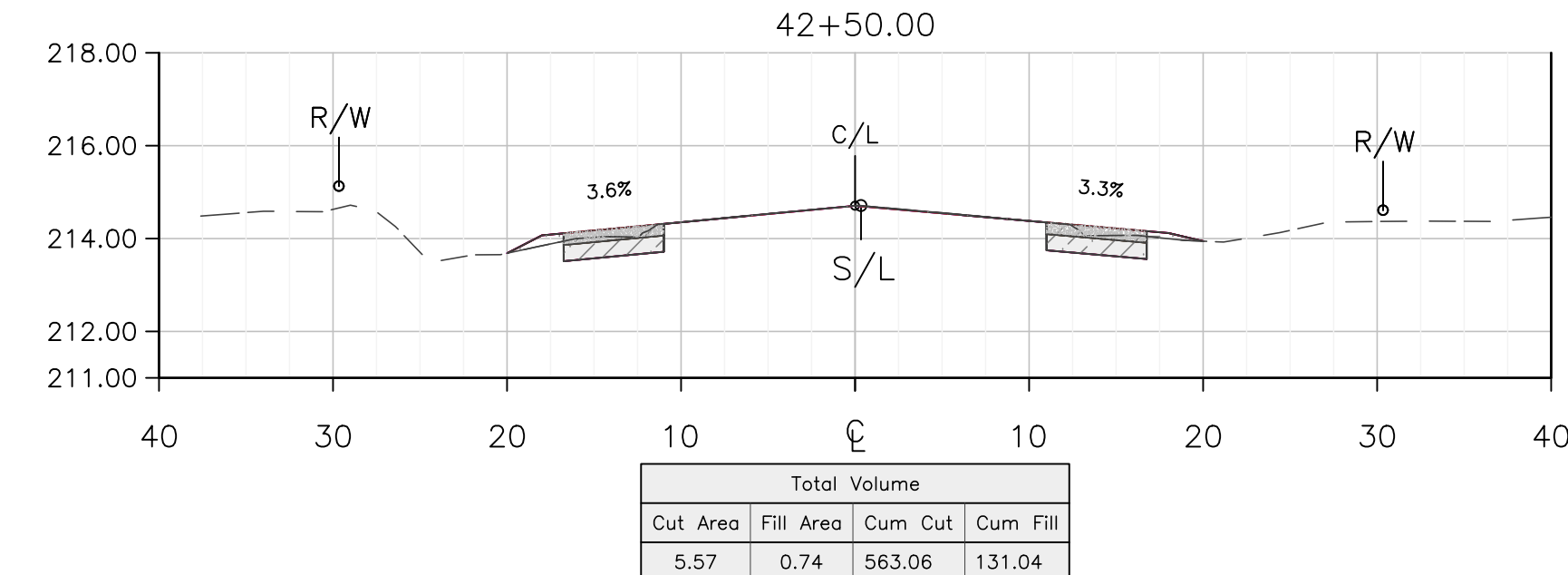
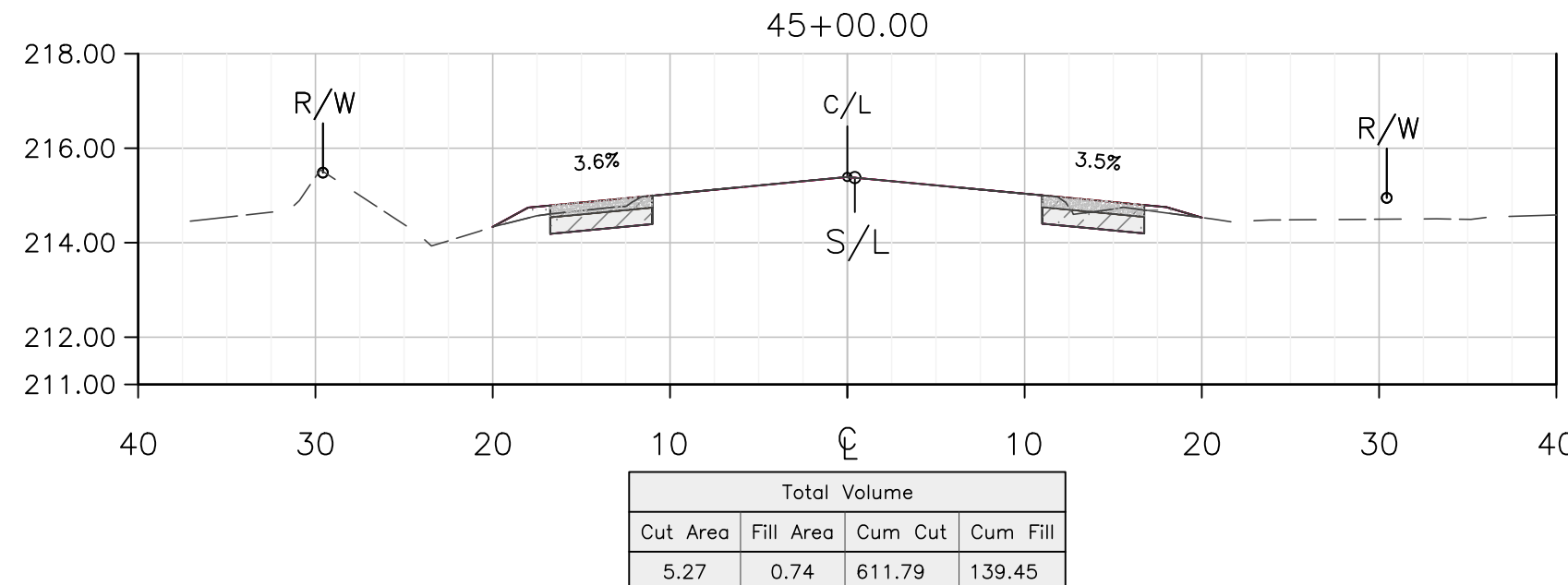
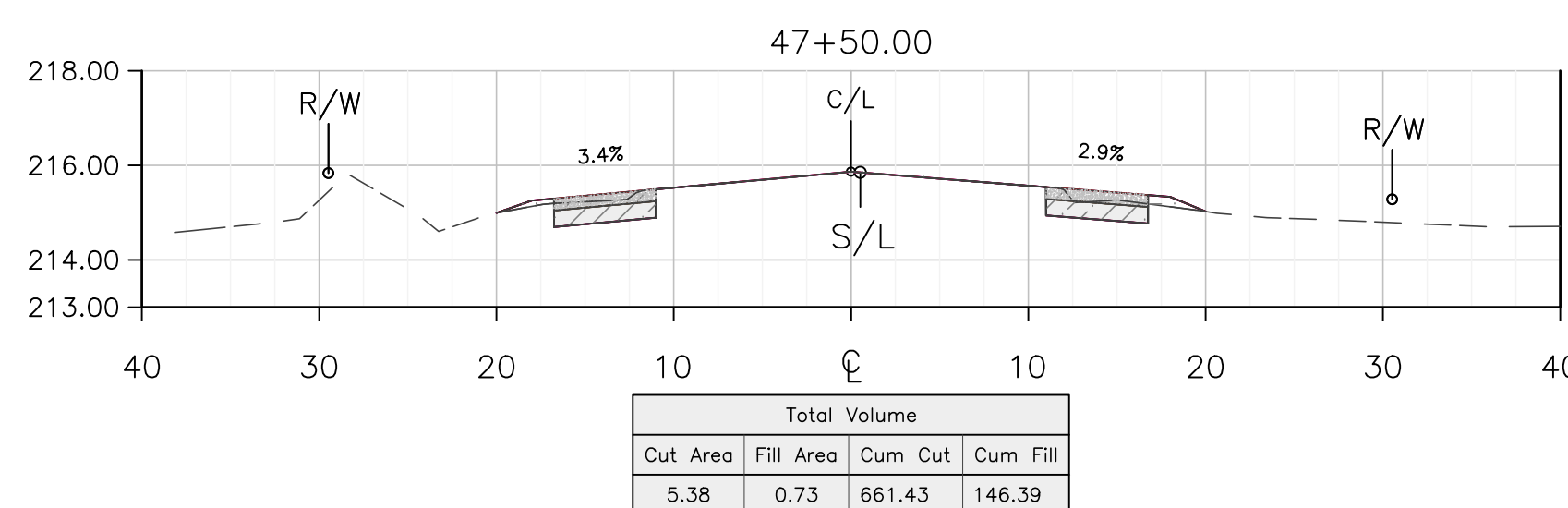
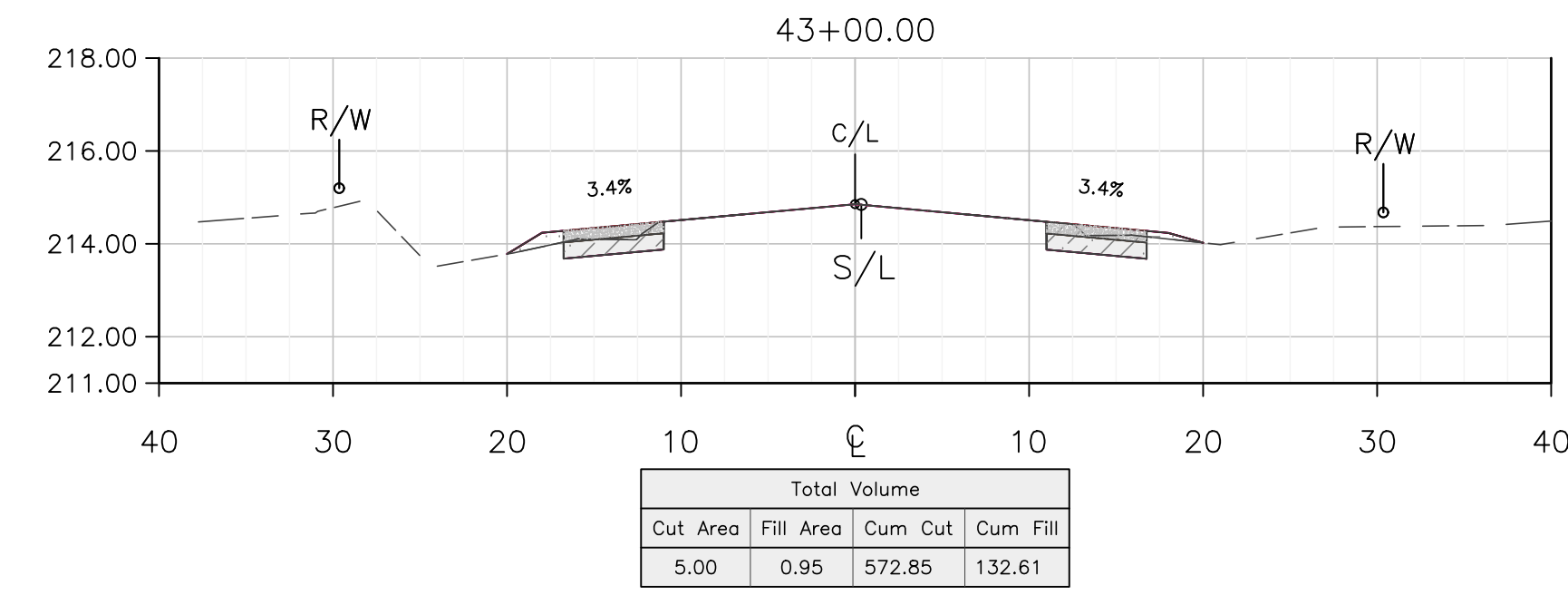
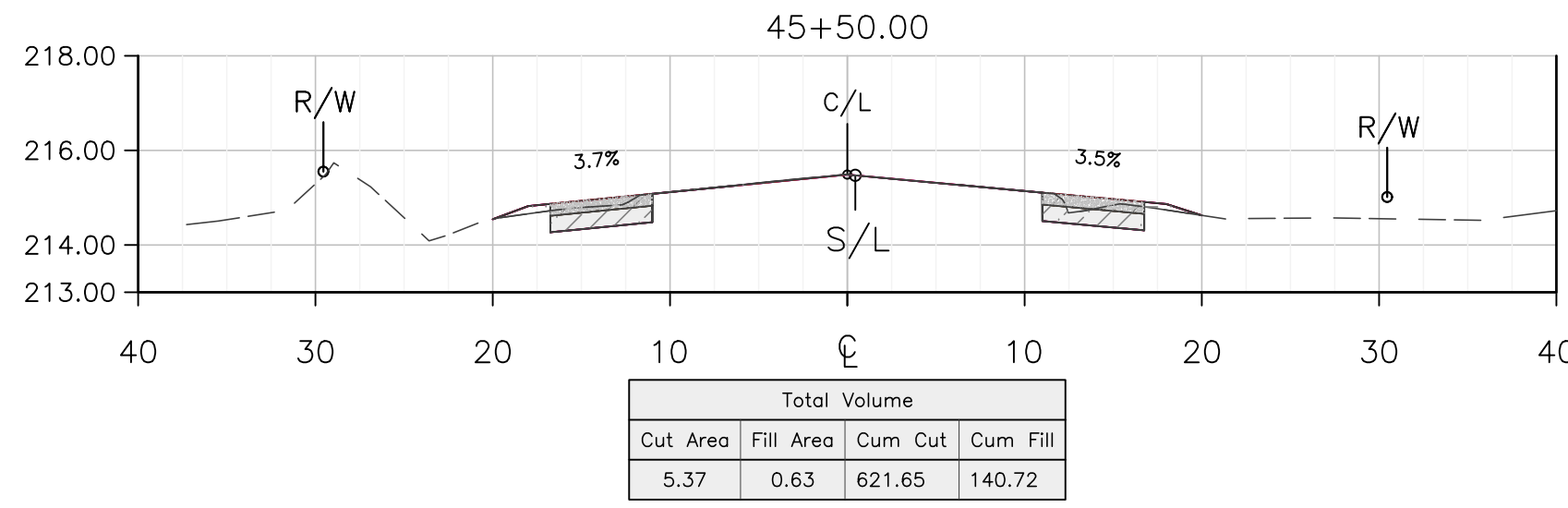
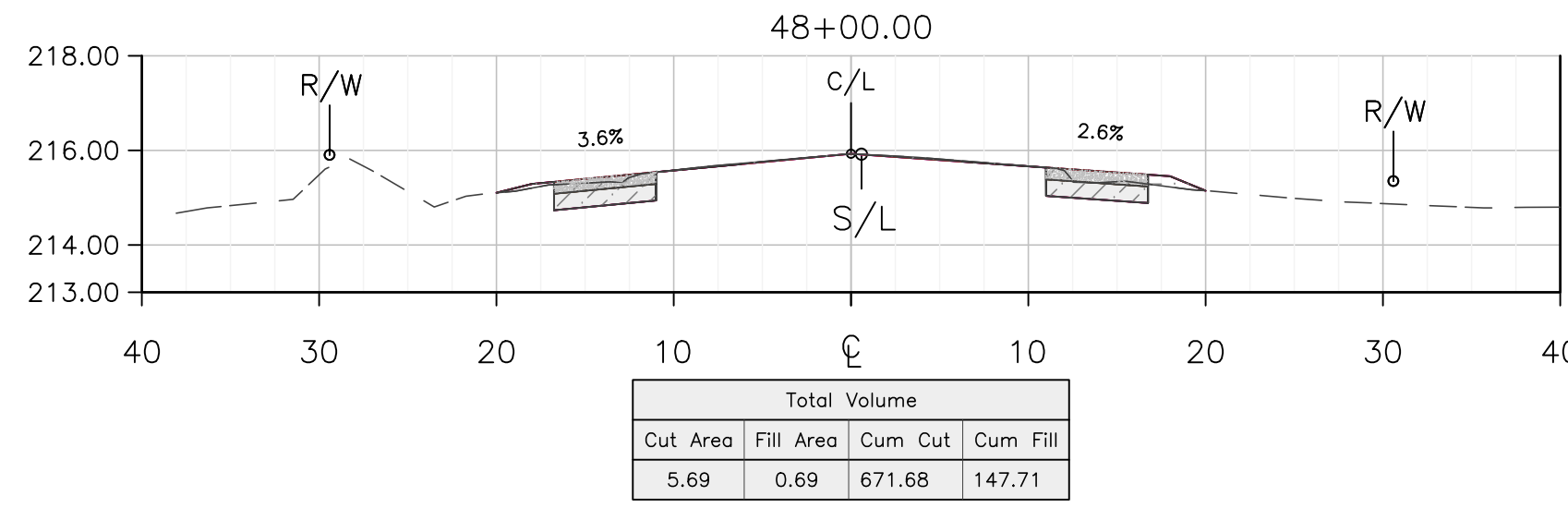
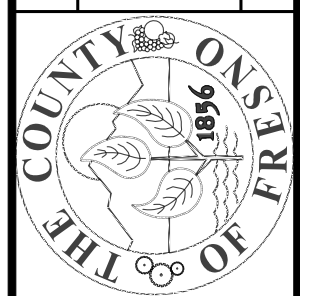

THESE CROSS SECTIONS ARE FOR THE CONTRACTOR'S INFORMATION ONLY. THEY ARE NOT TO BE CONSIDERED TO BE PART OF THE CONTRACT DOCUMENTS AND SHALL HAVE NO BEARING WHATSOEVER ON THE INTERPRETATION OF THE STANDARD SPECIFICATIONS, THE STANDARD PLANS, THE SPECIAL PROVISIONS, NOR SHALL THEY HAVE ANY BEARING WHATSOEVER ON THE INTERPRETATION OF THE OTHER PUBLICATIONS REFERENCED THEREIN.

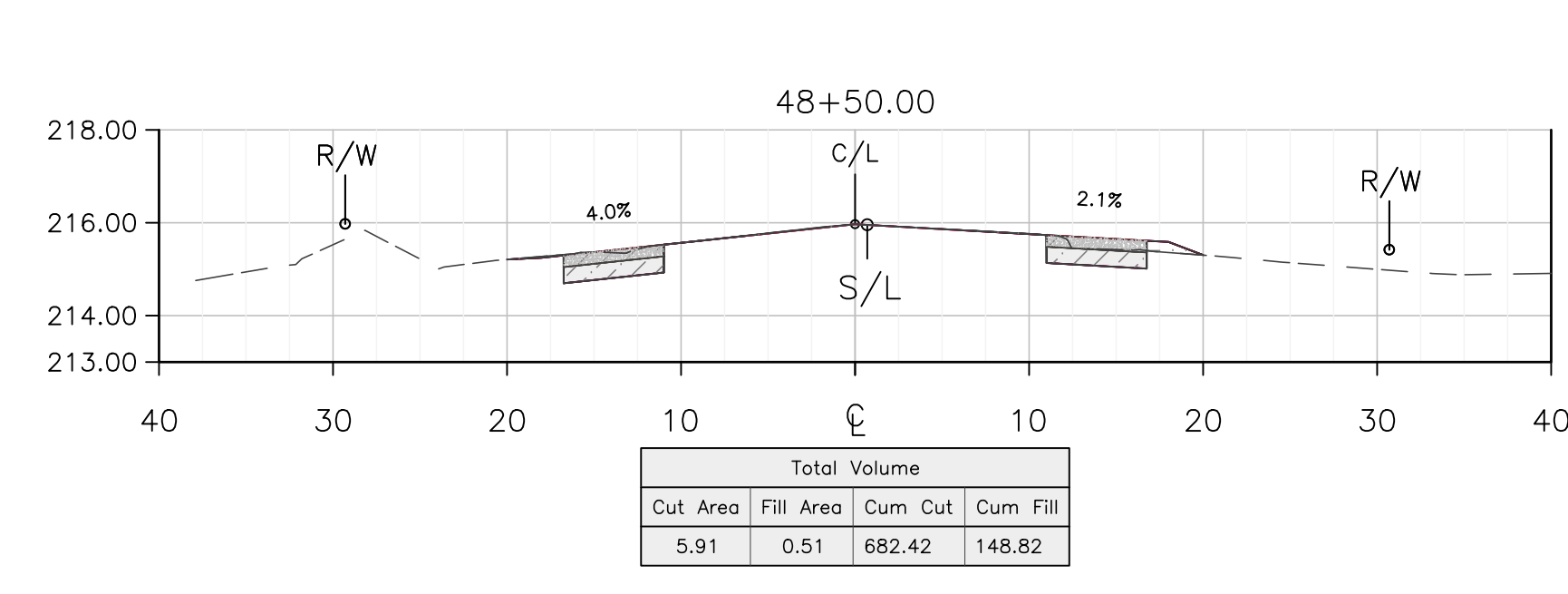
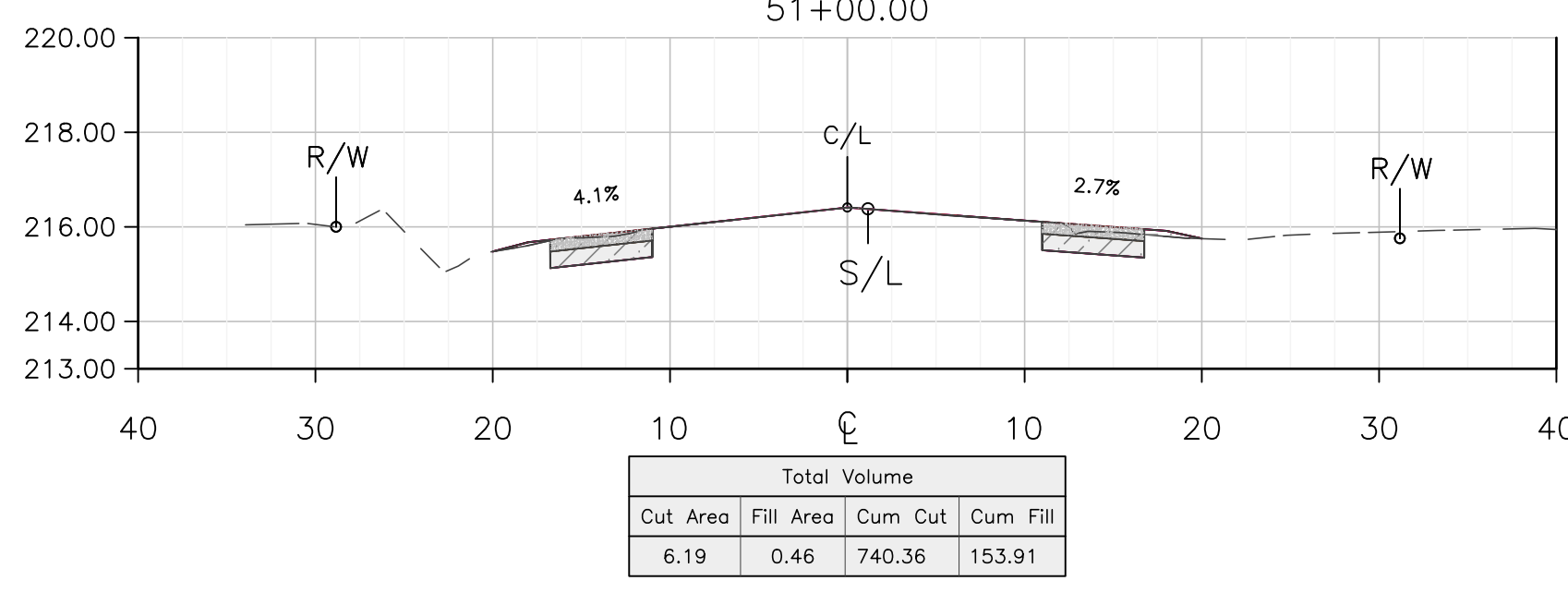
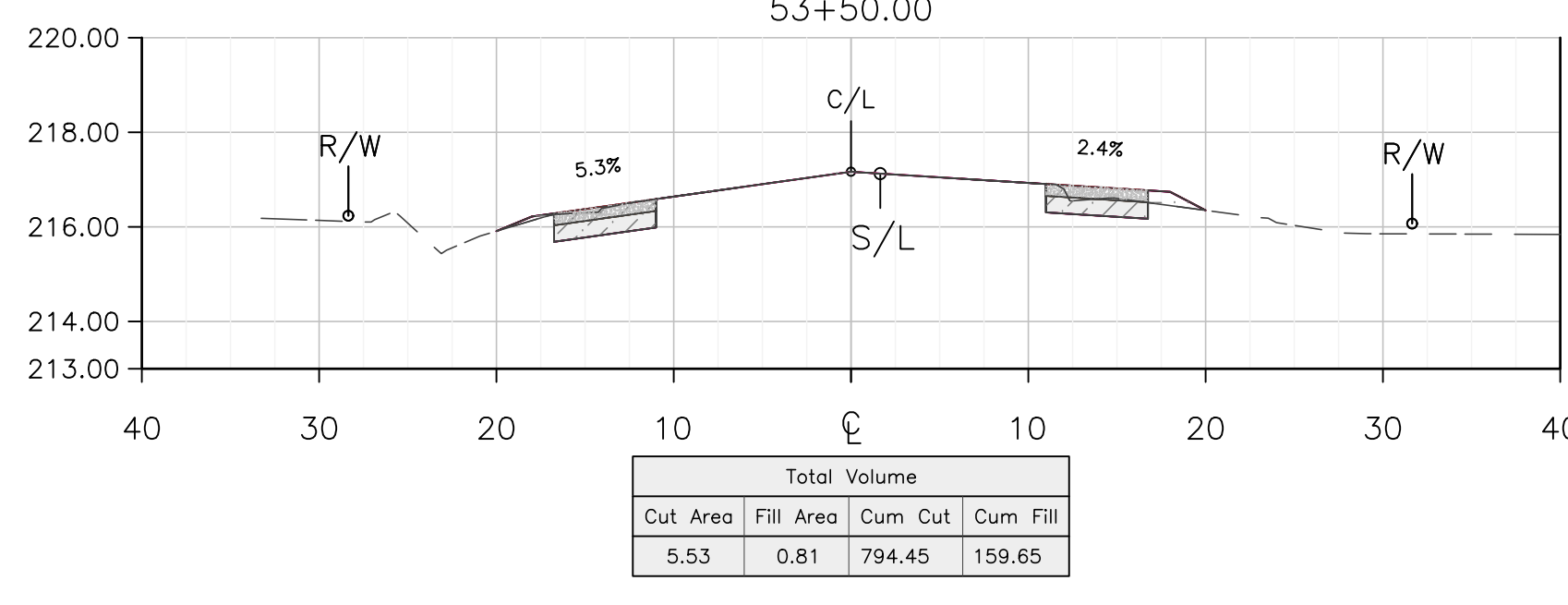
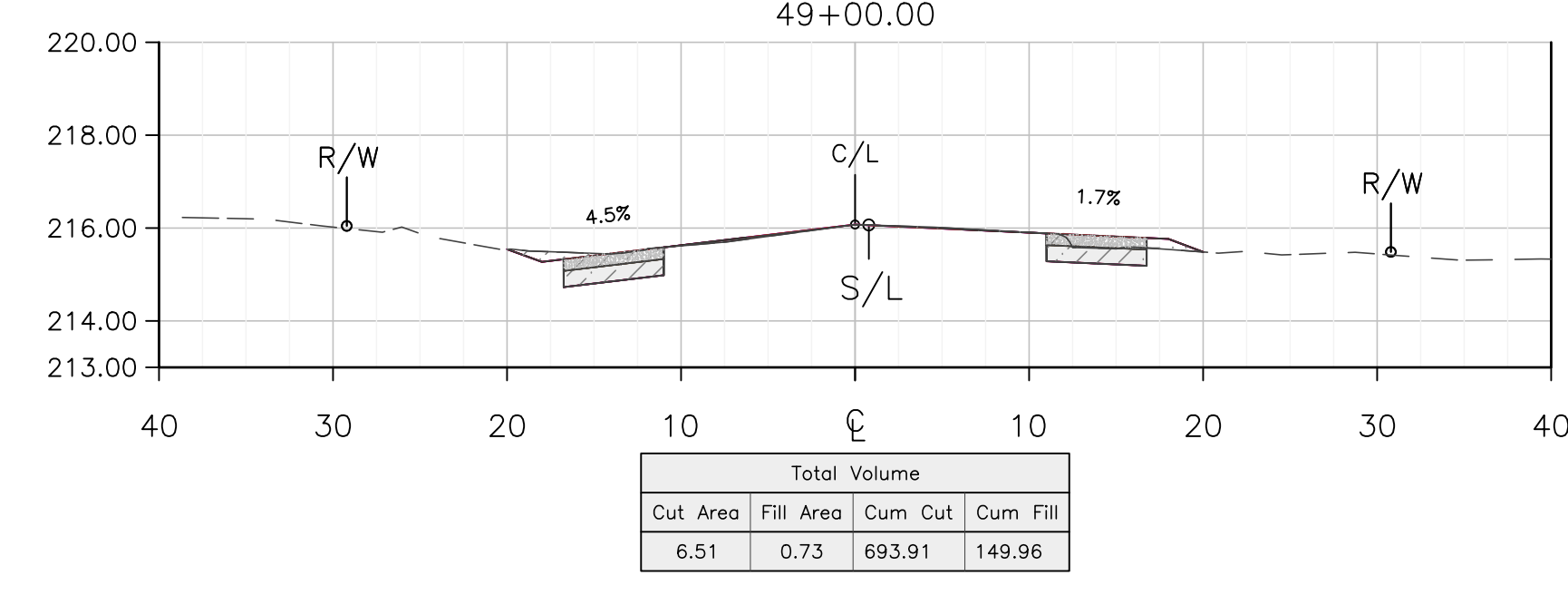
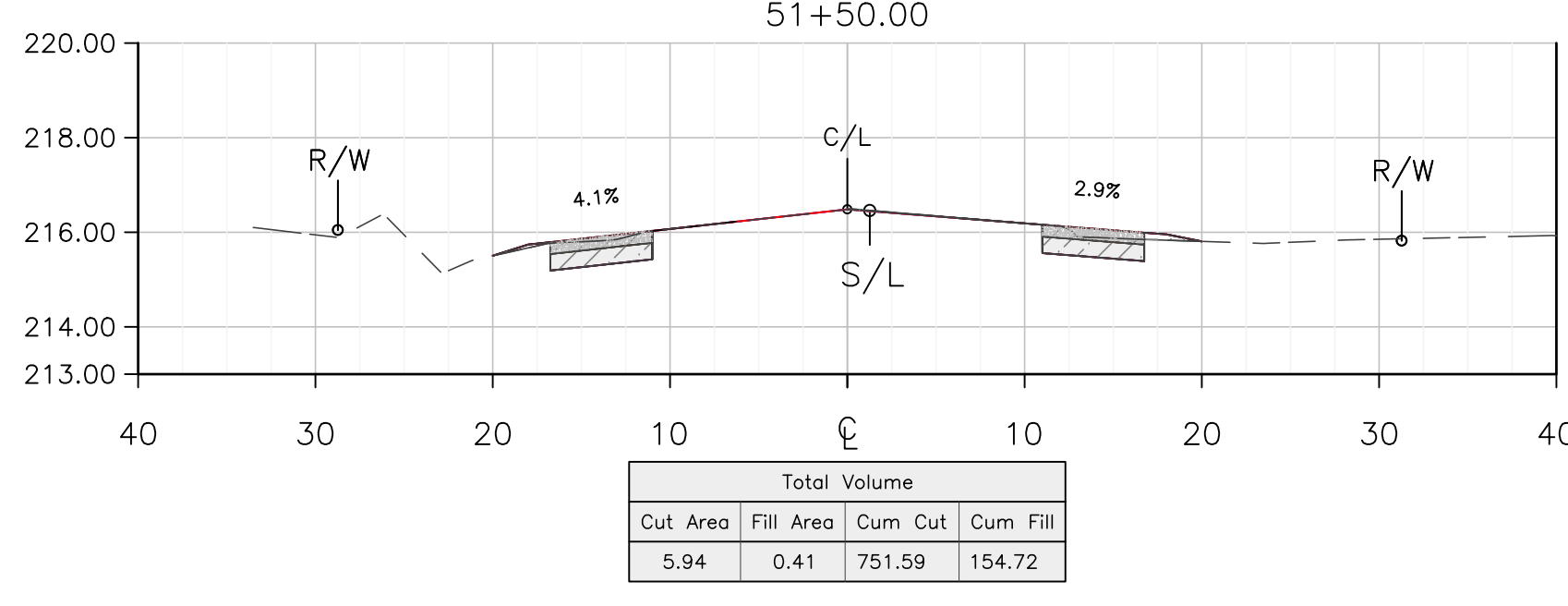
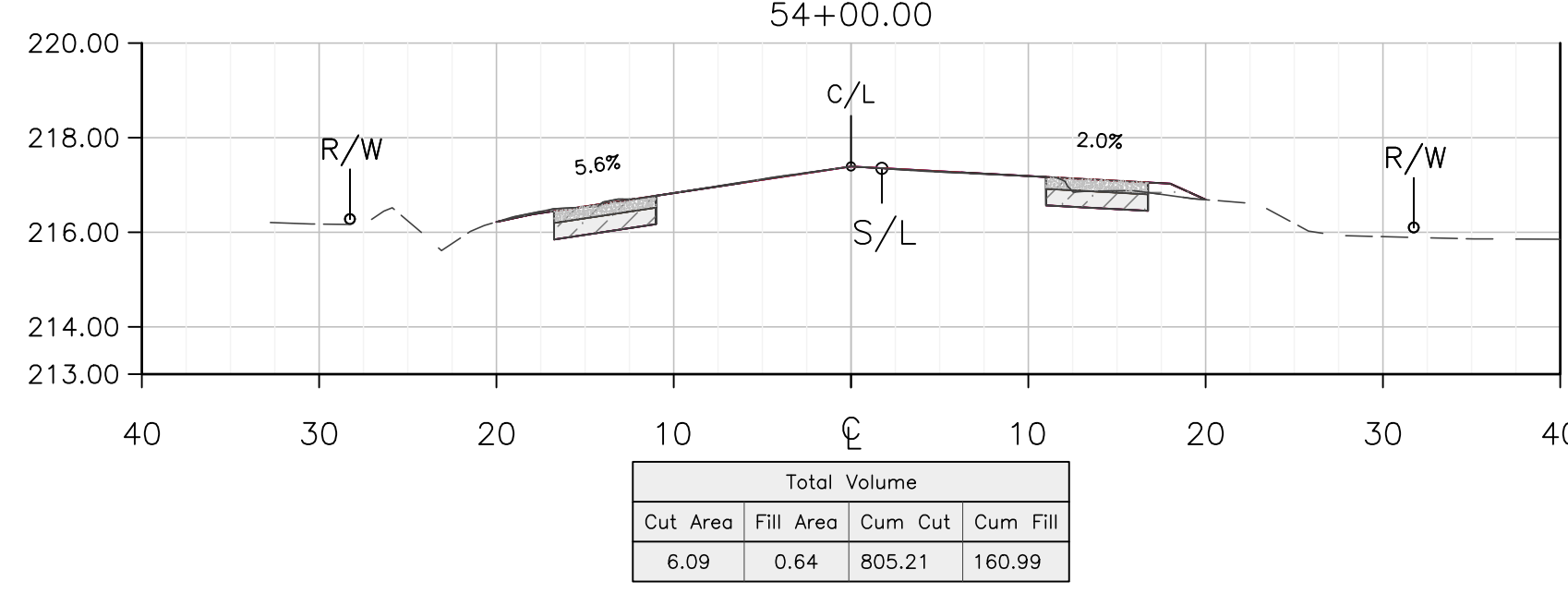
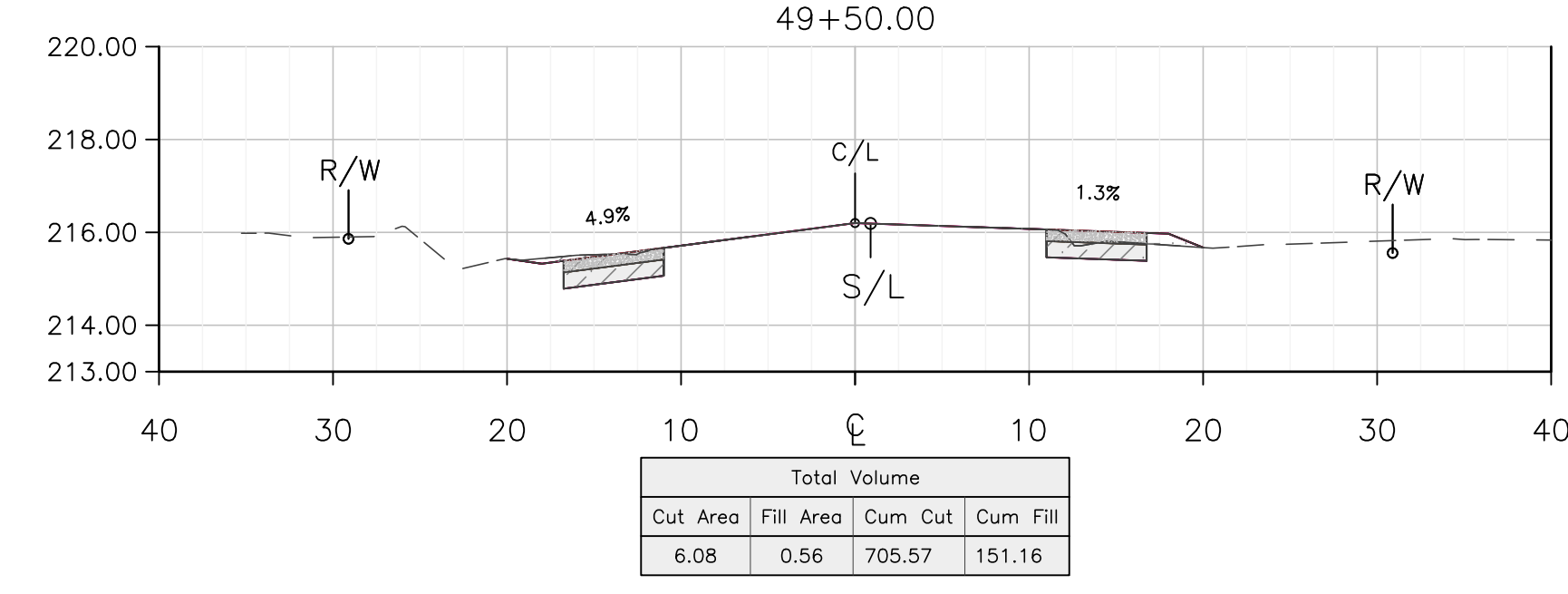
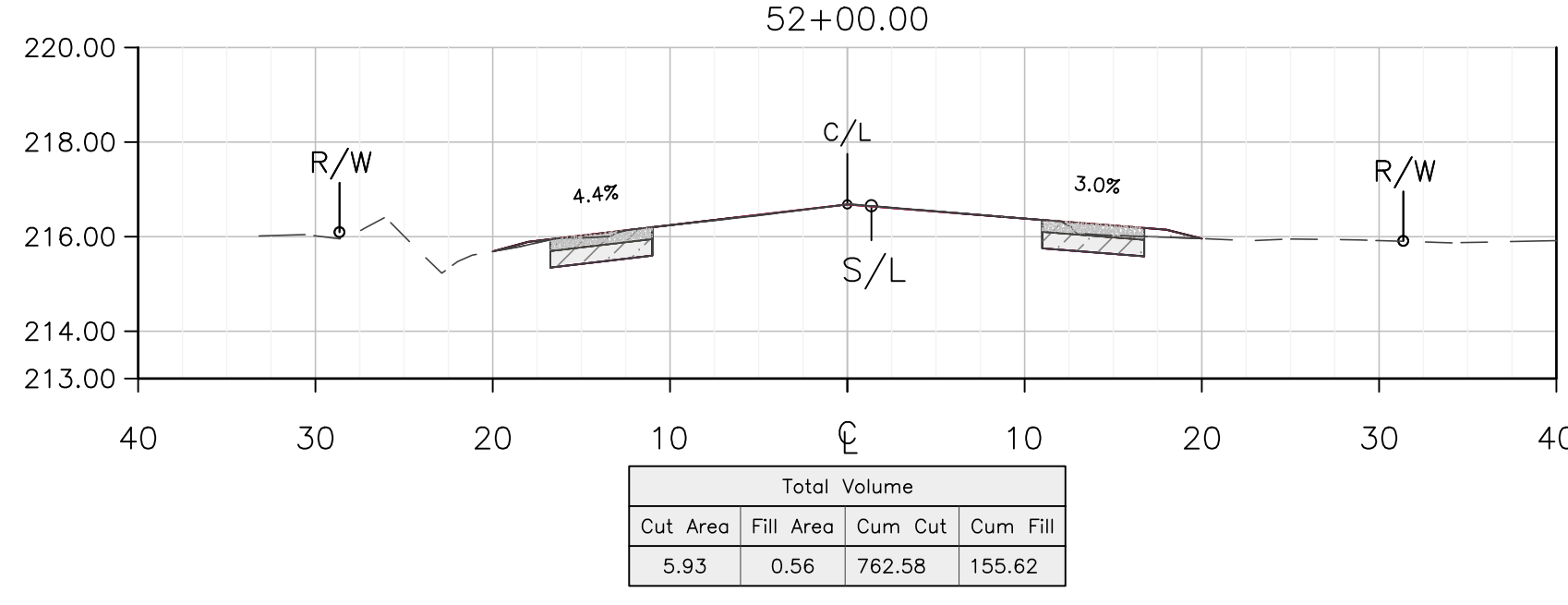
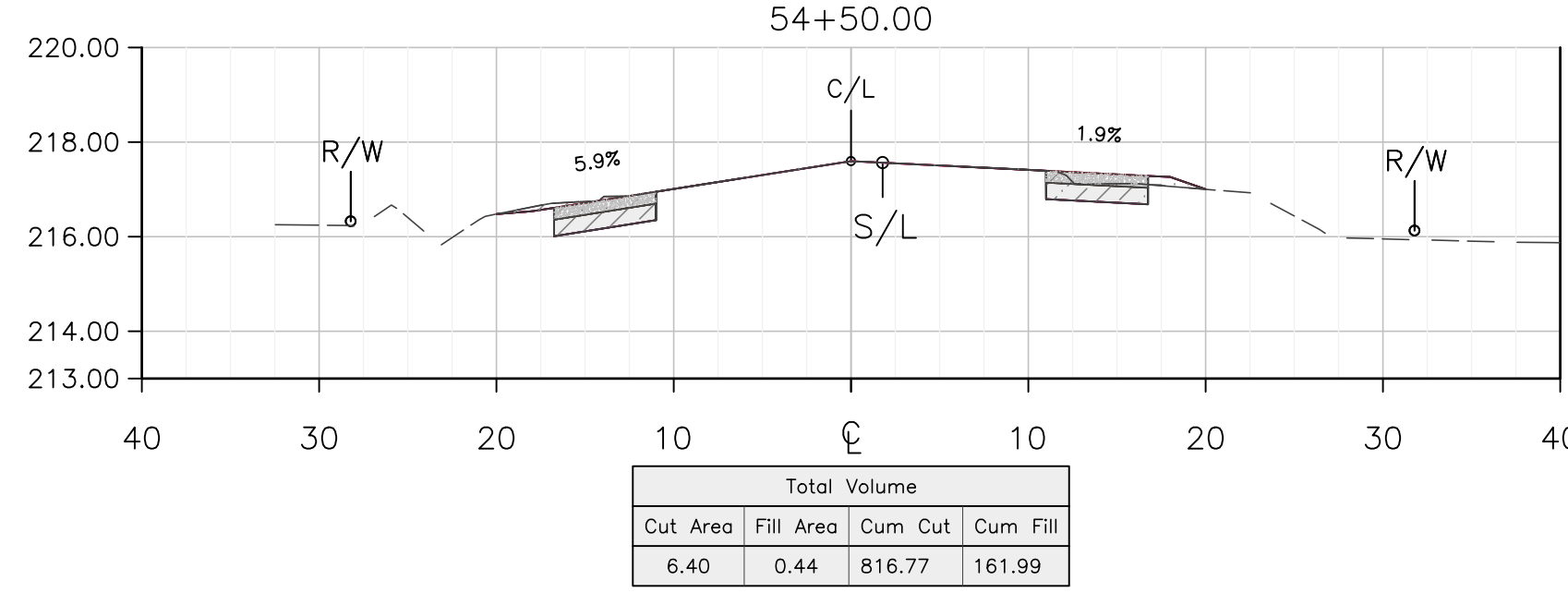
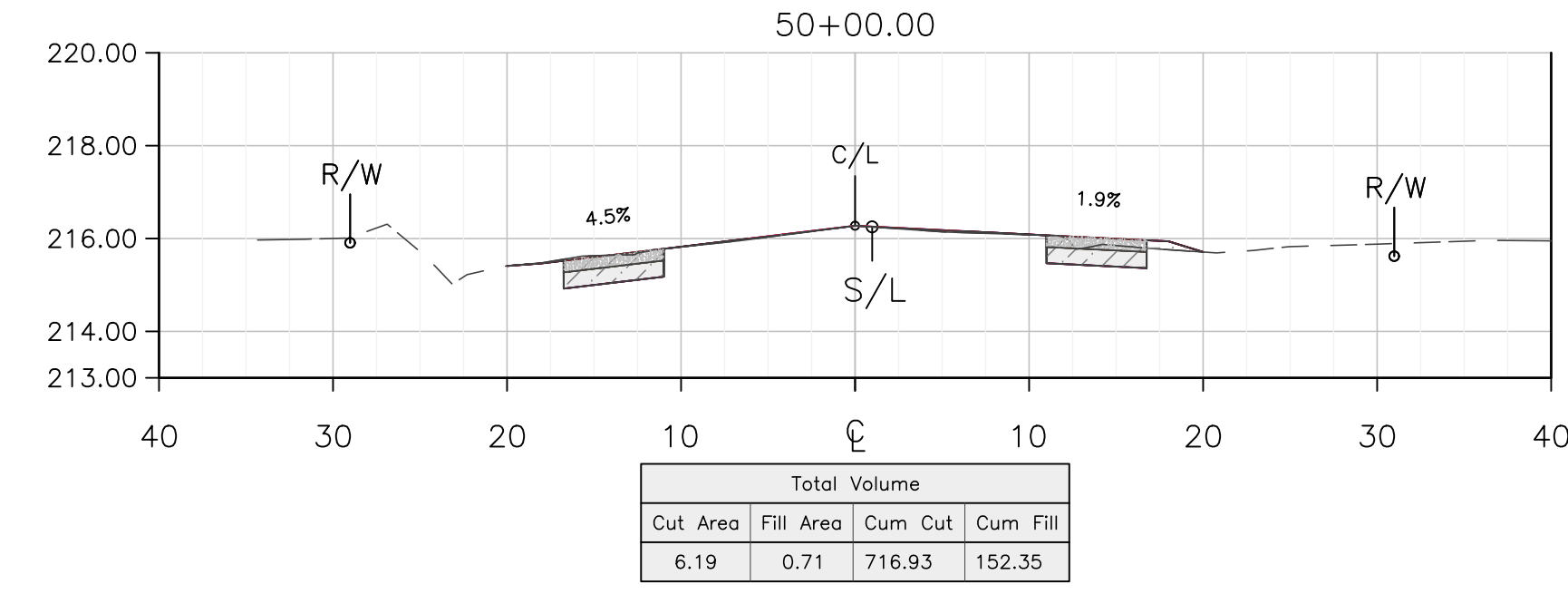
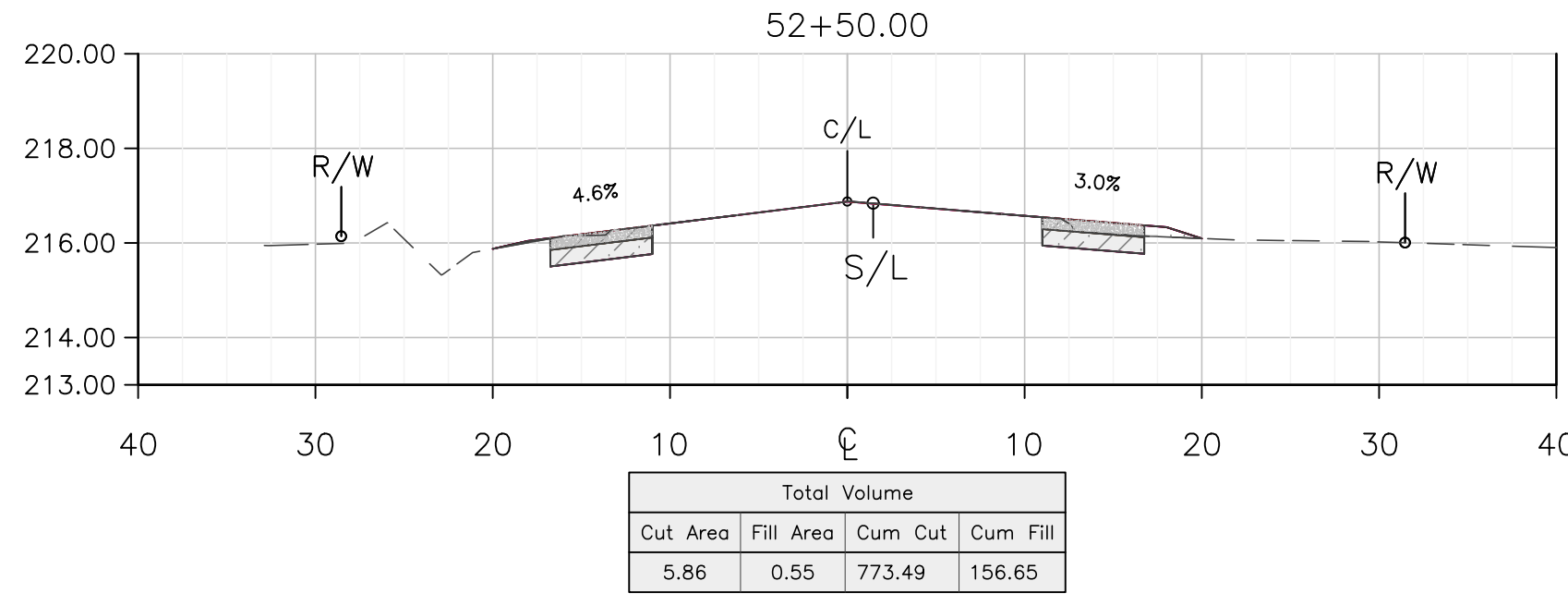
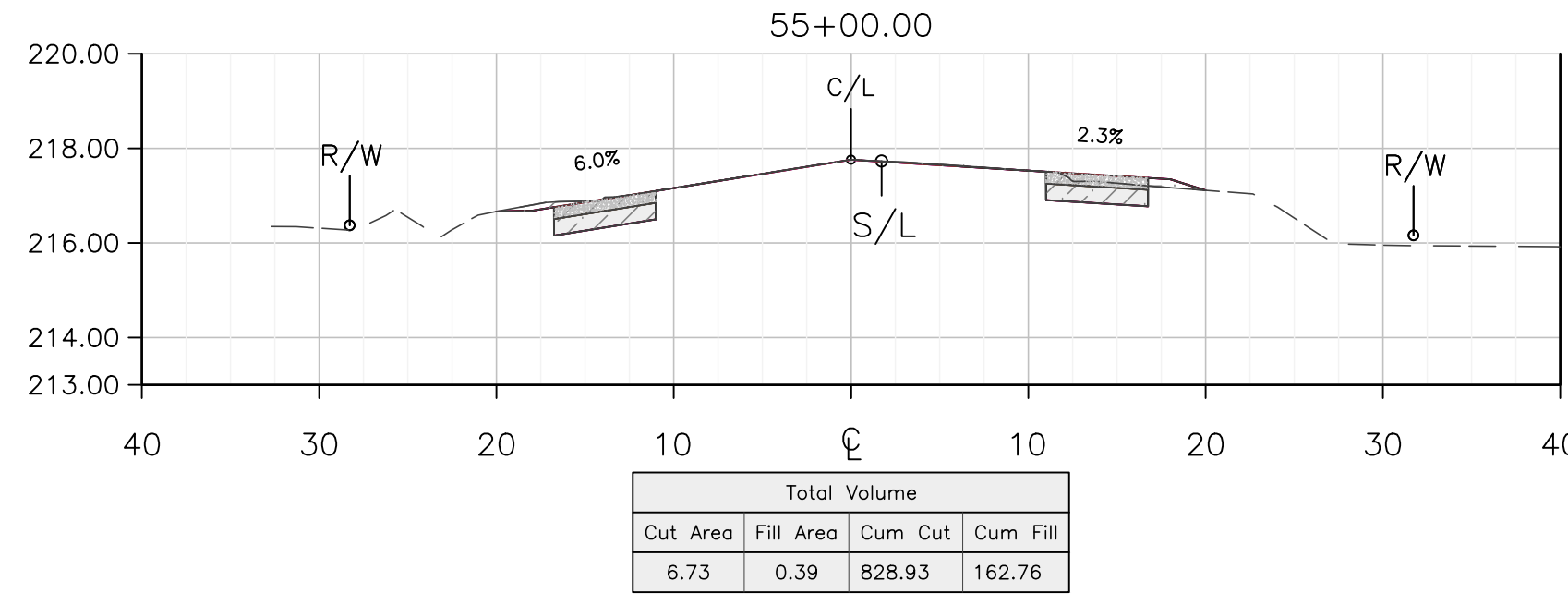
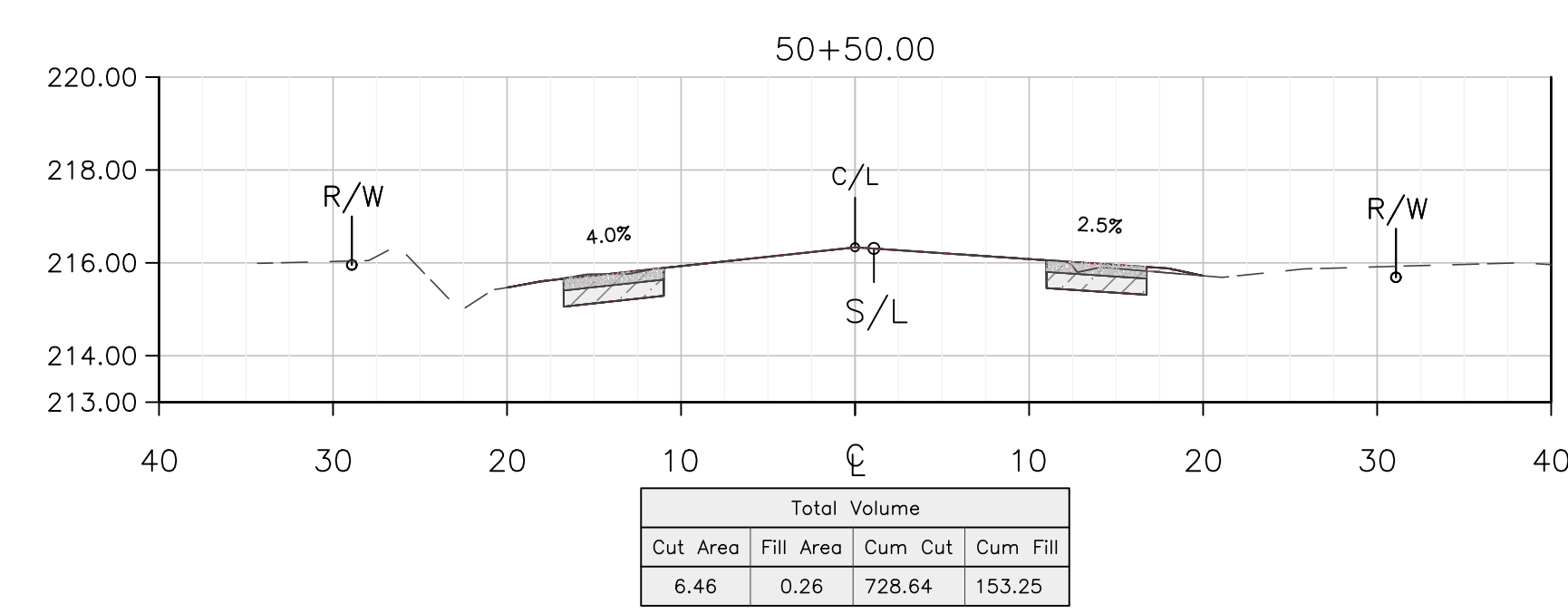
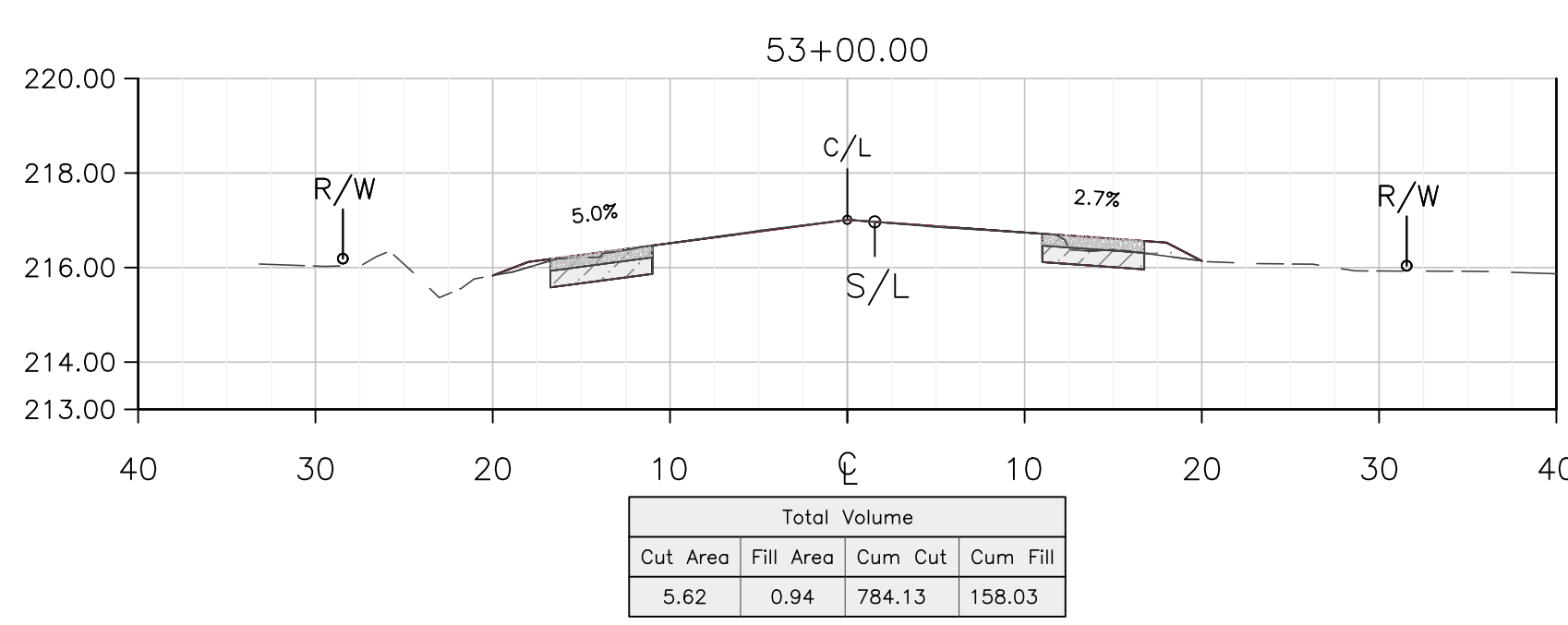
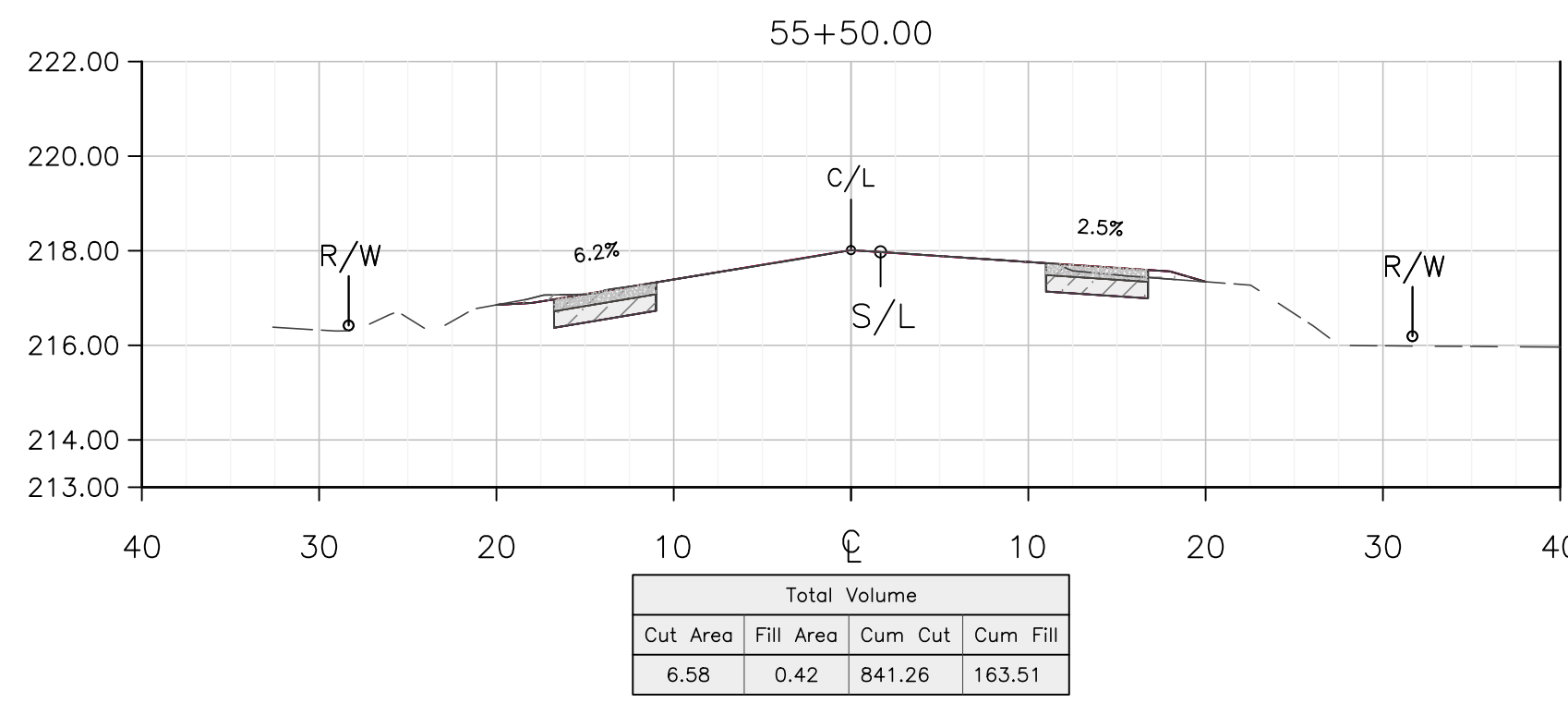
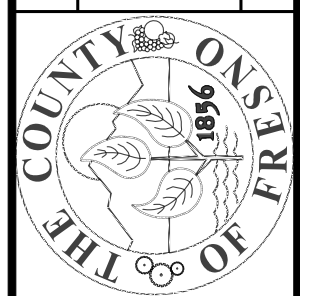

THESE CROSS SECTIONS ARE FOR THE CONTRACTOR'S INFORMATION ONLY. THEY ARE NOT TO BE CONSIDERED TO BE PART OF THE CONTRACT DOCUMENTS AND SHALL HAVE NO BEARING WHATSOEVER ON THE INTERPRETATION OF THE STANDARD SPECIFICATIONS, THE STANDARD PLANS, THE SPECIAL PROVISIONS, NOR SHALL THEY HAVE ANY BEARING WHATSOEVER ON THE INTERPRETATION OF THE OTHER PUBLICATIONS REFERENCED THEREIN.

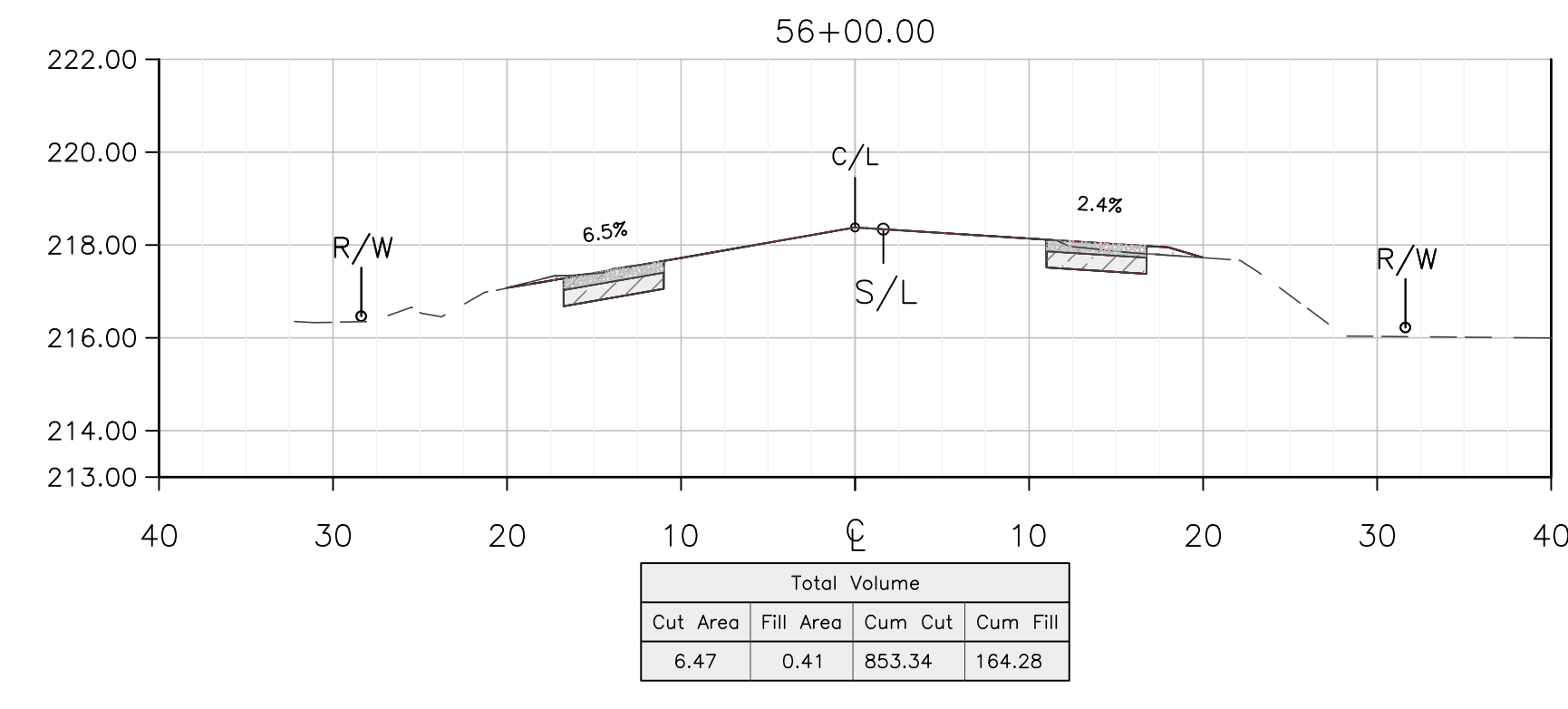
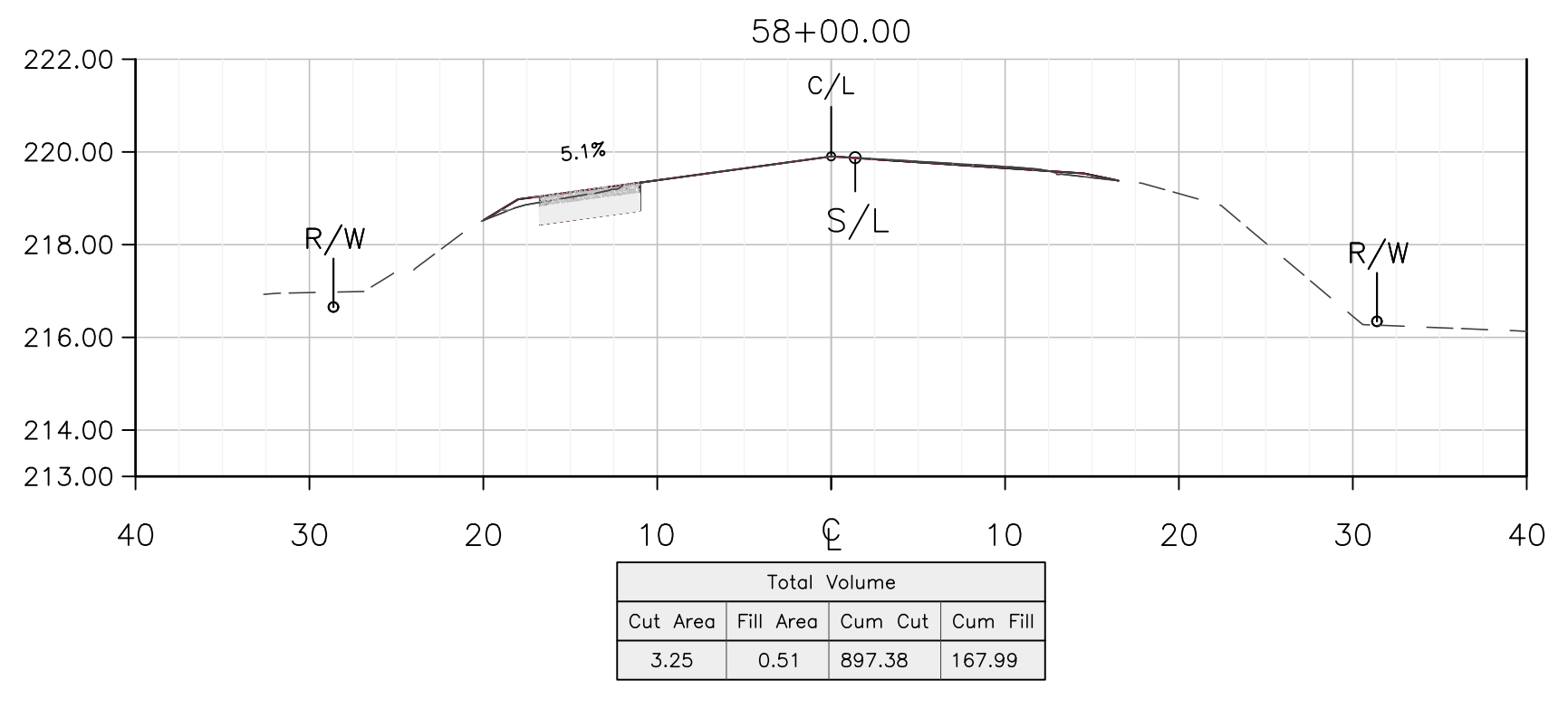
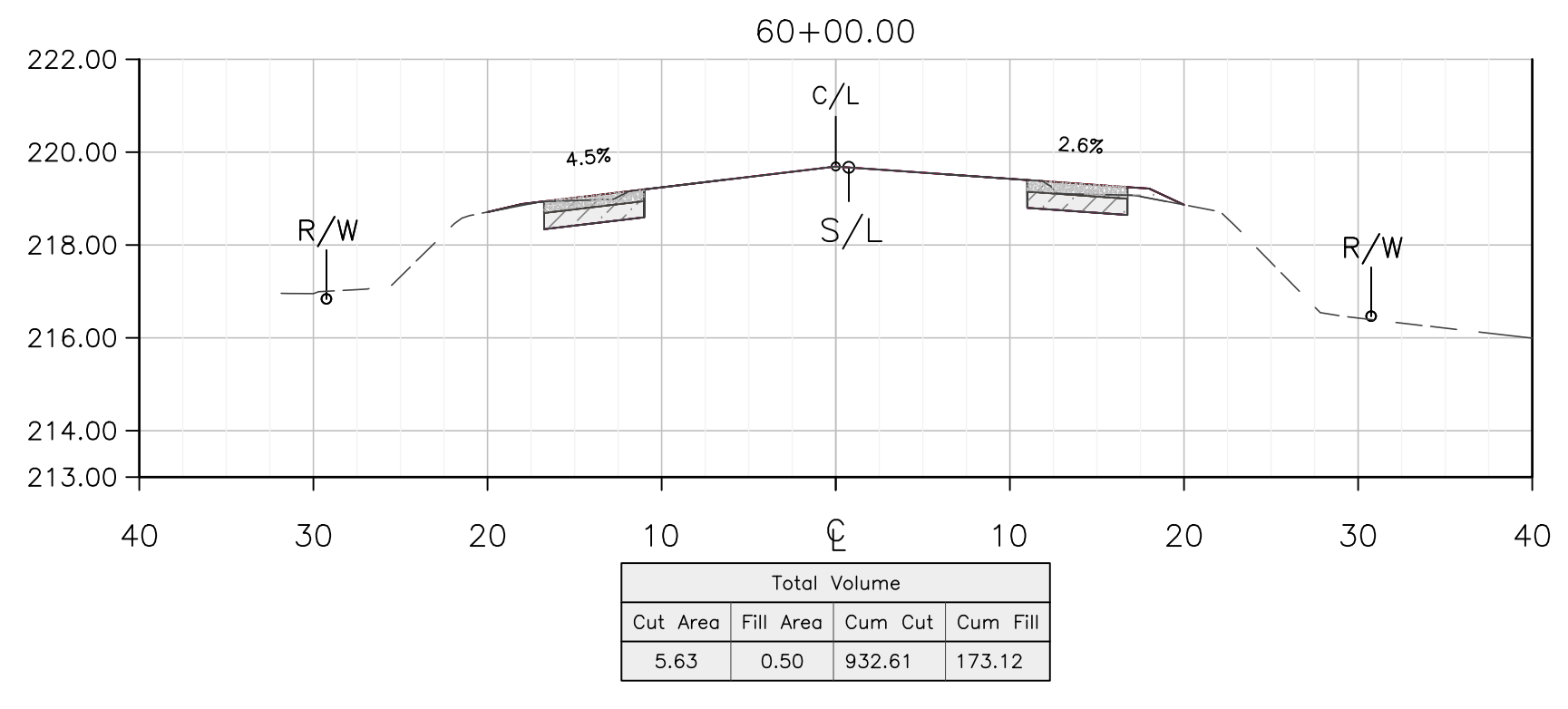
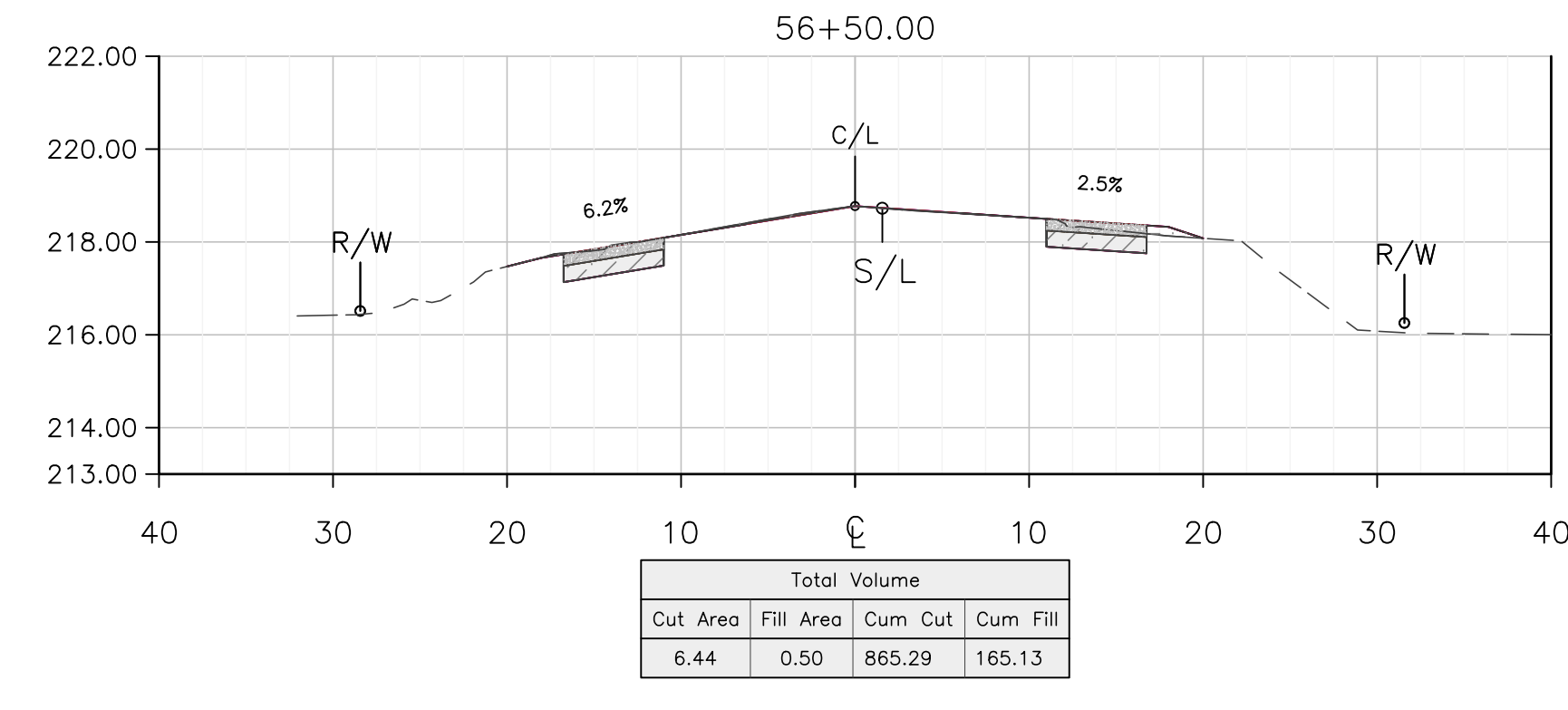
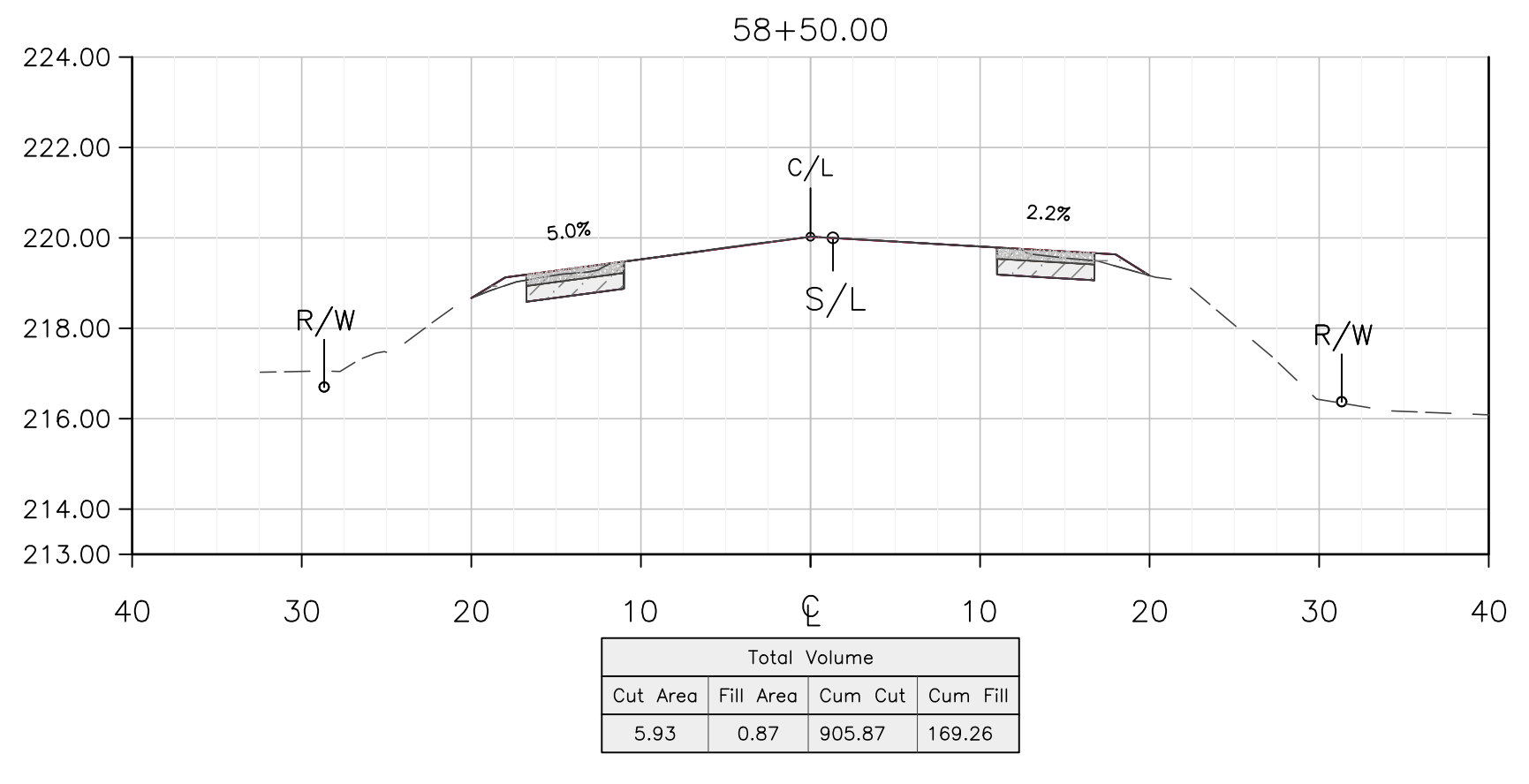
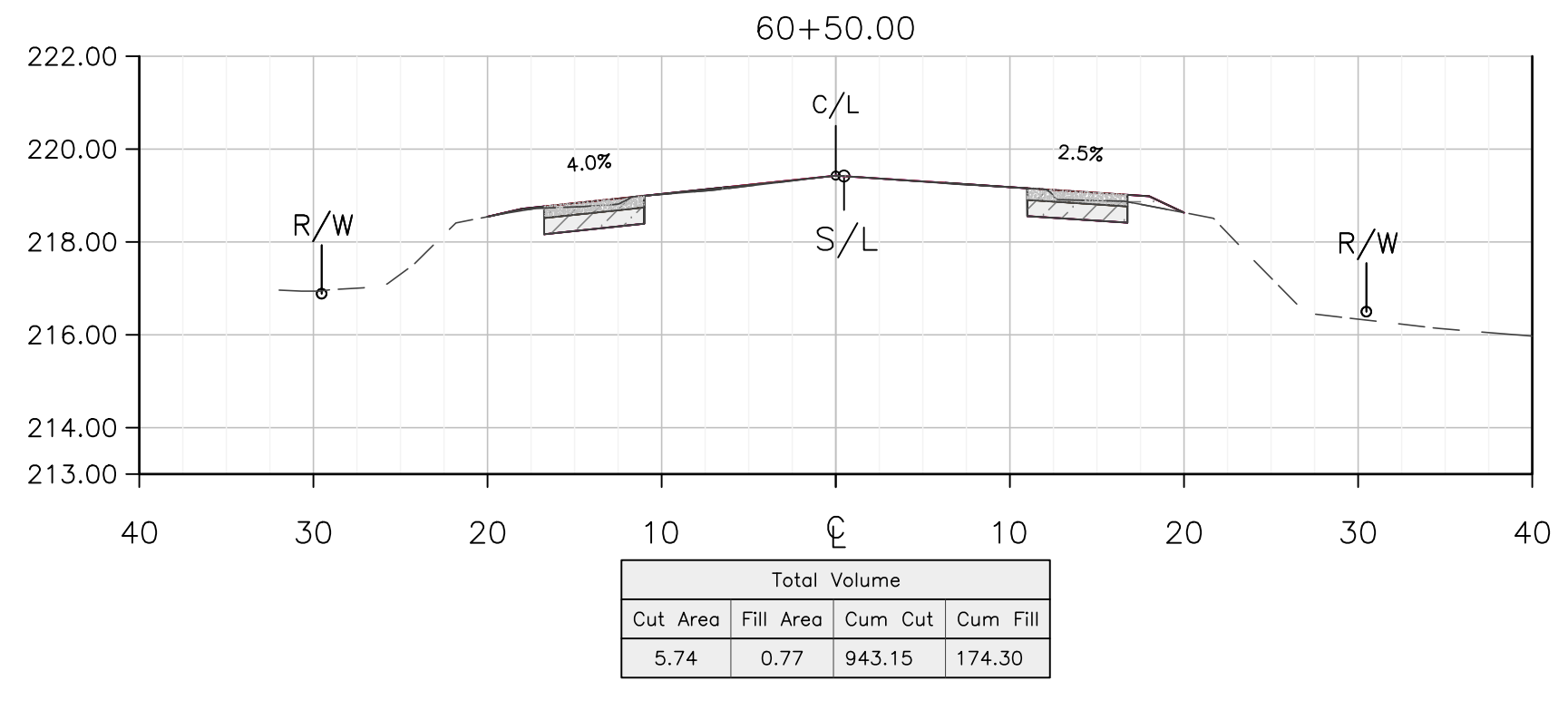
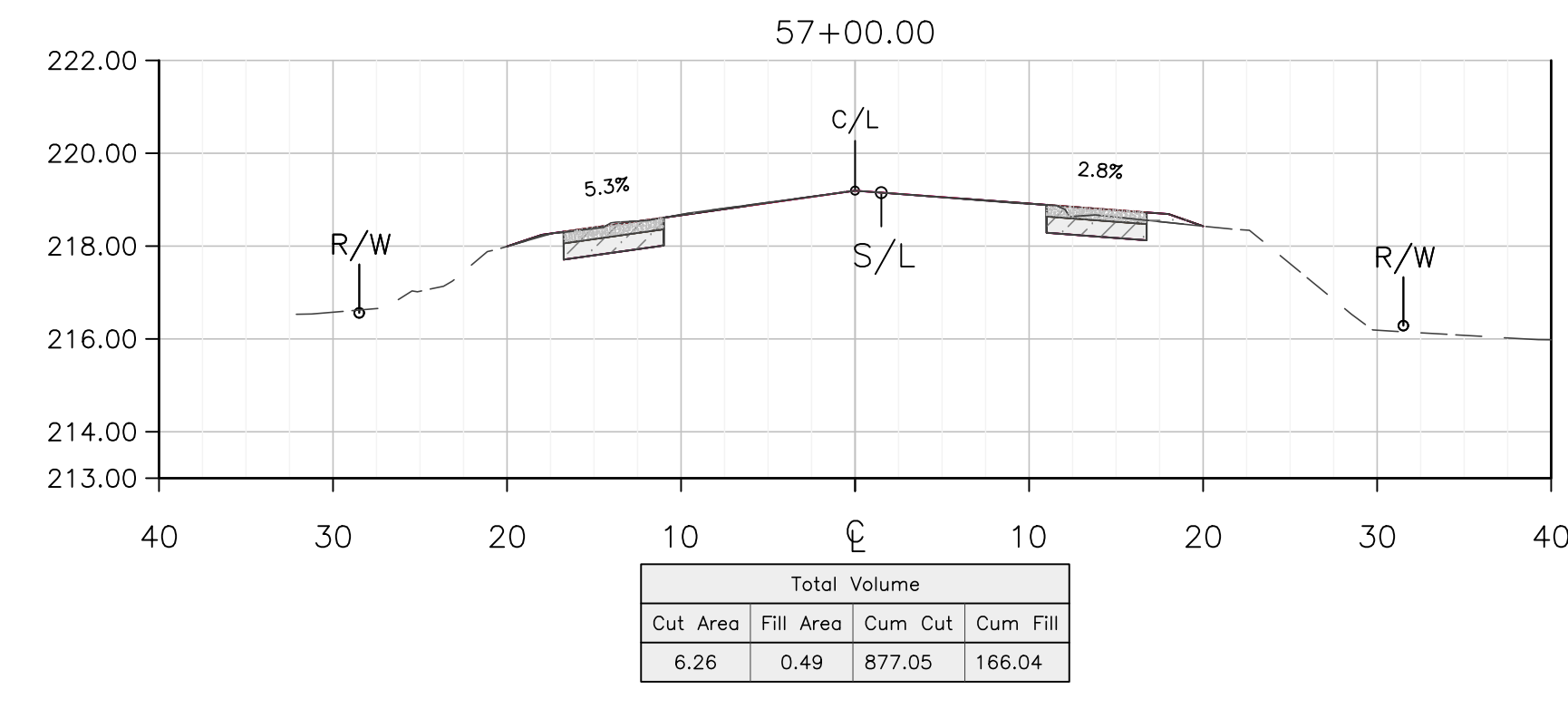
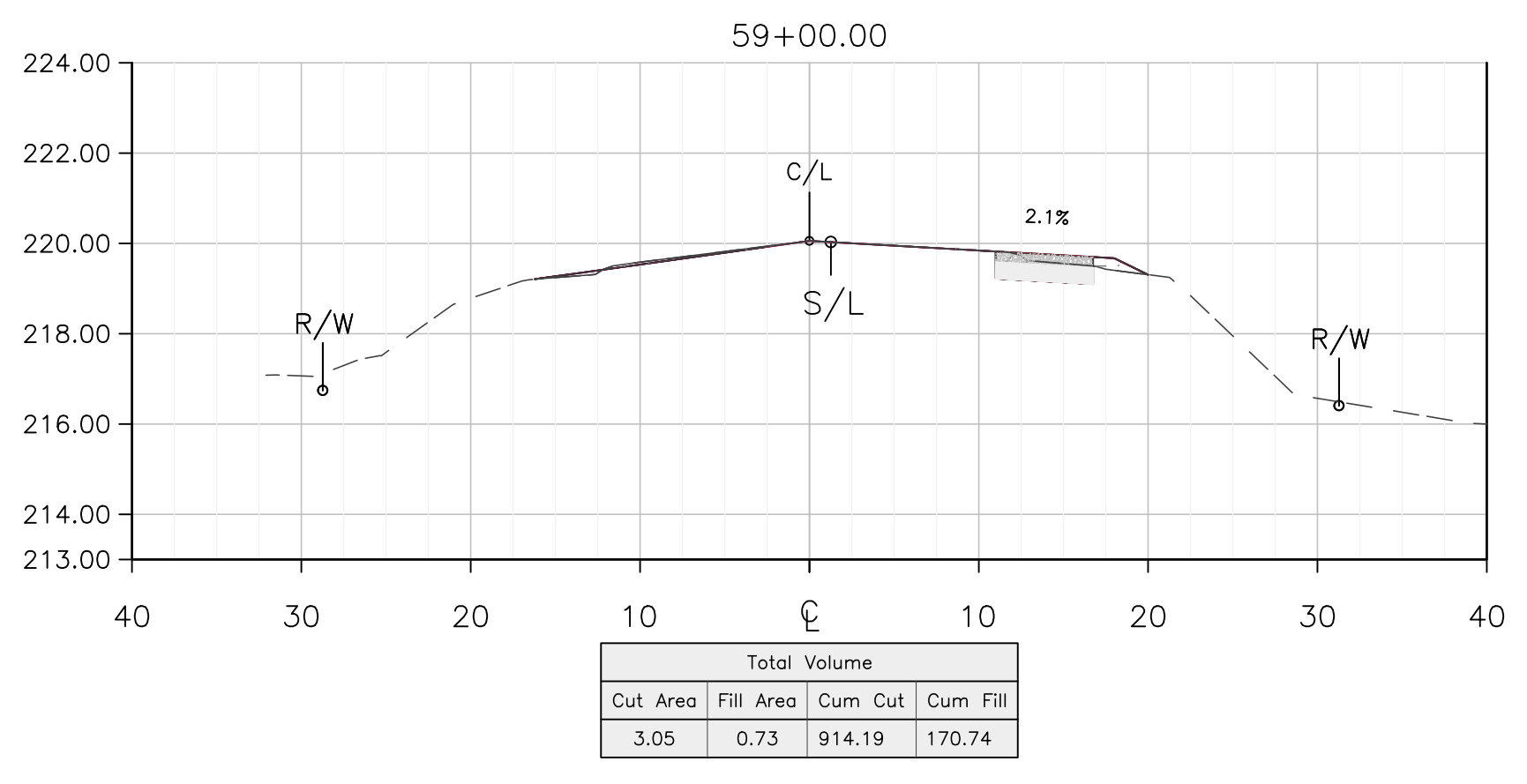
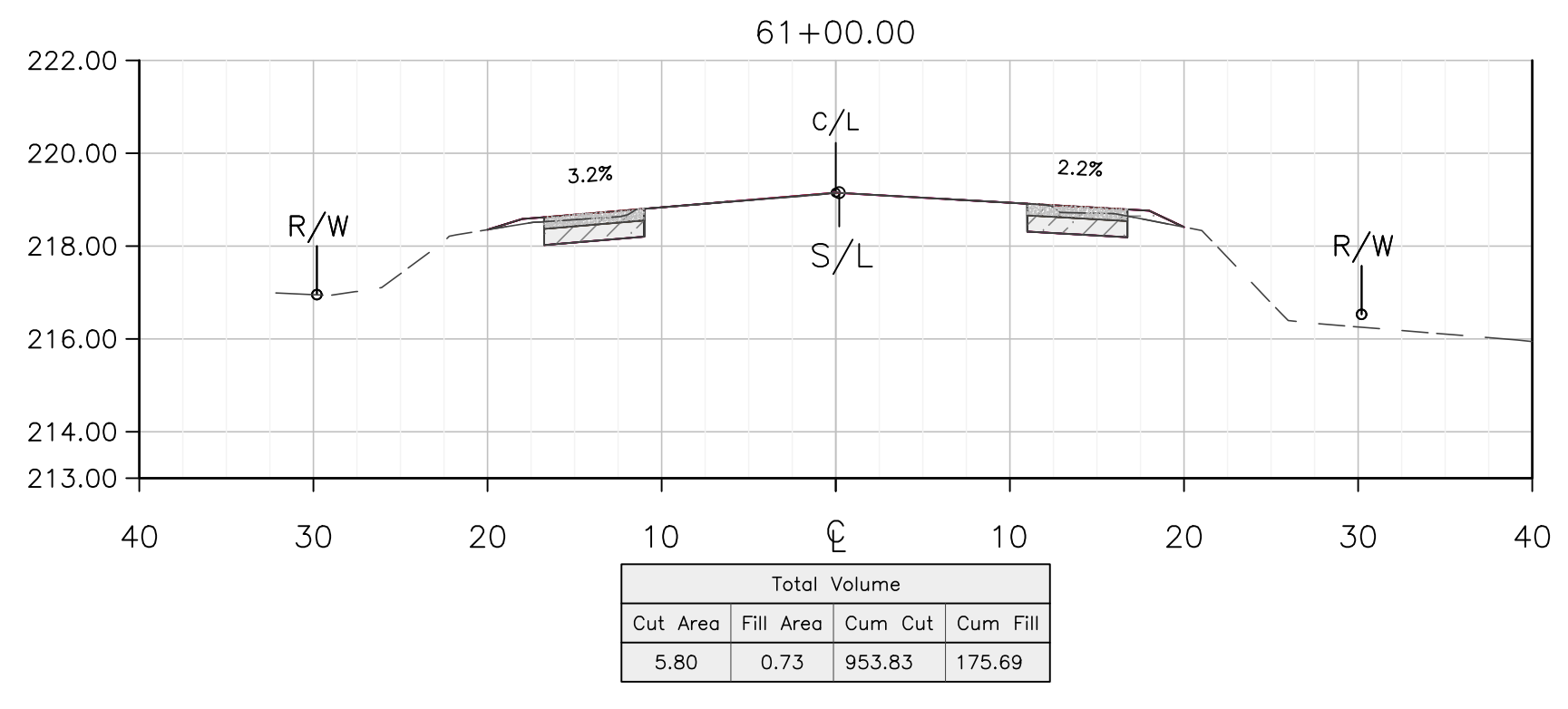
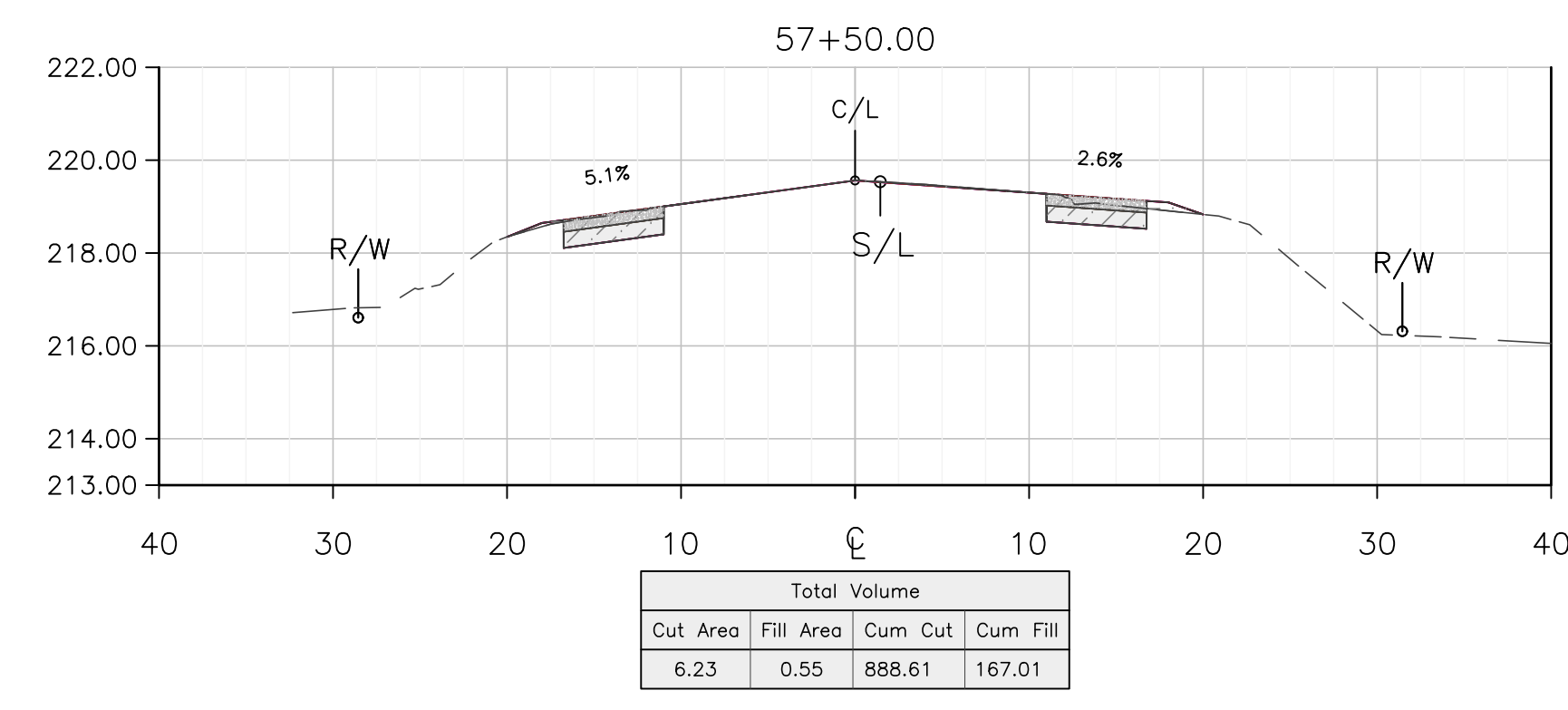
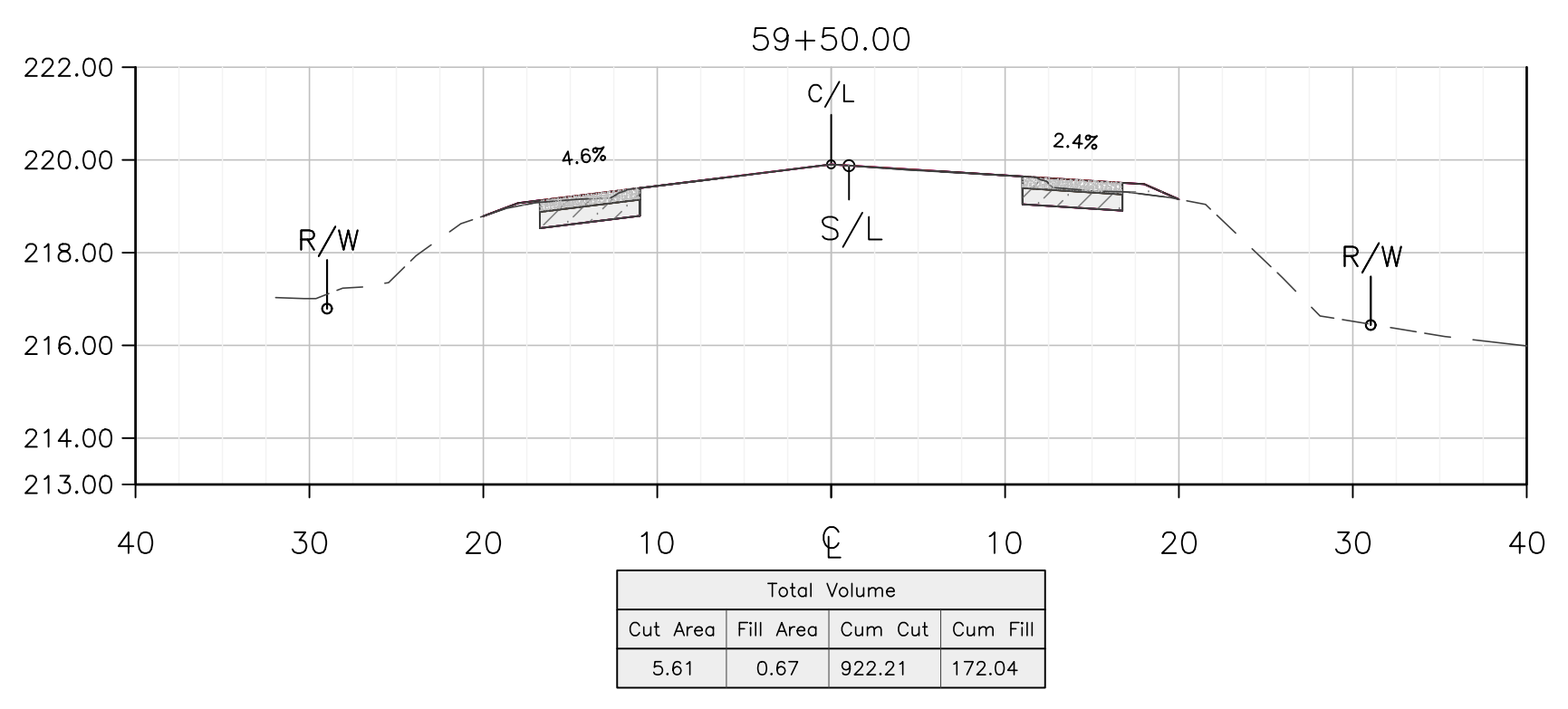
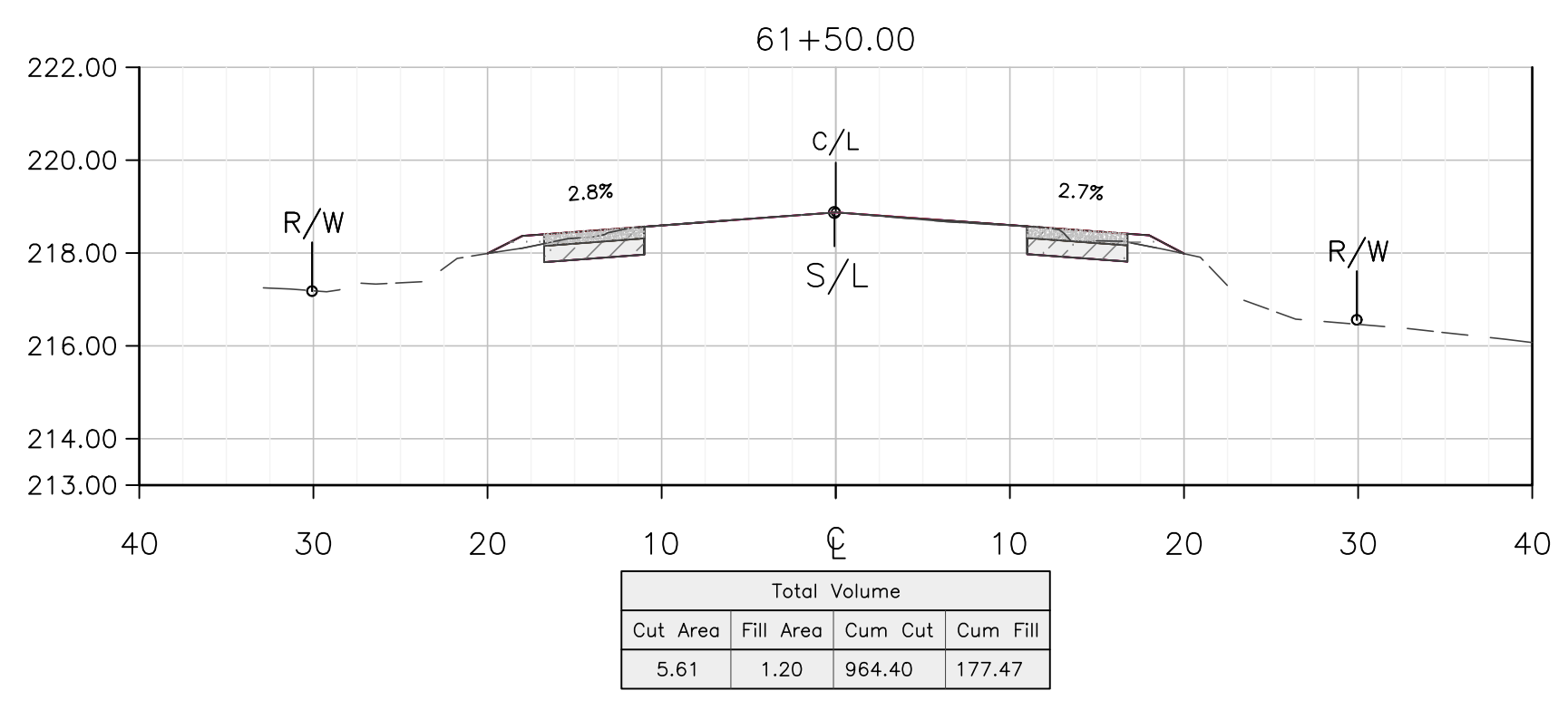

THESE CROSS SECTIONS ARE FOR THE CONTRACTOR'S INFORMATION ONLY. THEY ARE NOT TO BE CONSIDERED TO BE PART OF THE CONTRACT DOCUMENTS AND SHALL HAVE NO BEARING WHATSOEVER ON THE INTERPRETATION OF THE STANDARD SPECIFICATIONS, THE STANDARD PLANS, THE SPECIAL PROVISIONS, NOR SHALL THEY HAVE ANY BEARING WHATSOEVER ON THE INTERPRETATION OF THE OTHER PUBLICATIONS REFERENCED THEREIN.

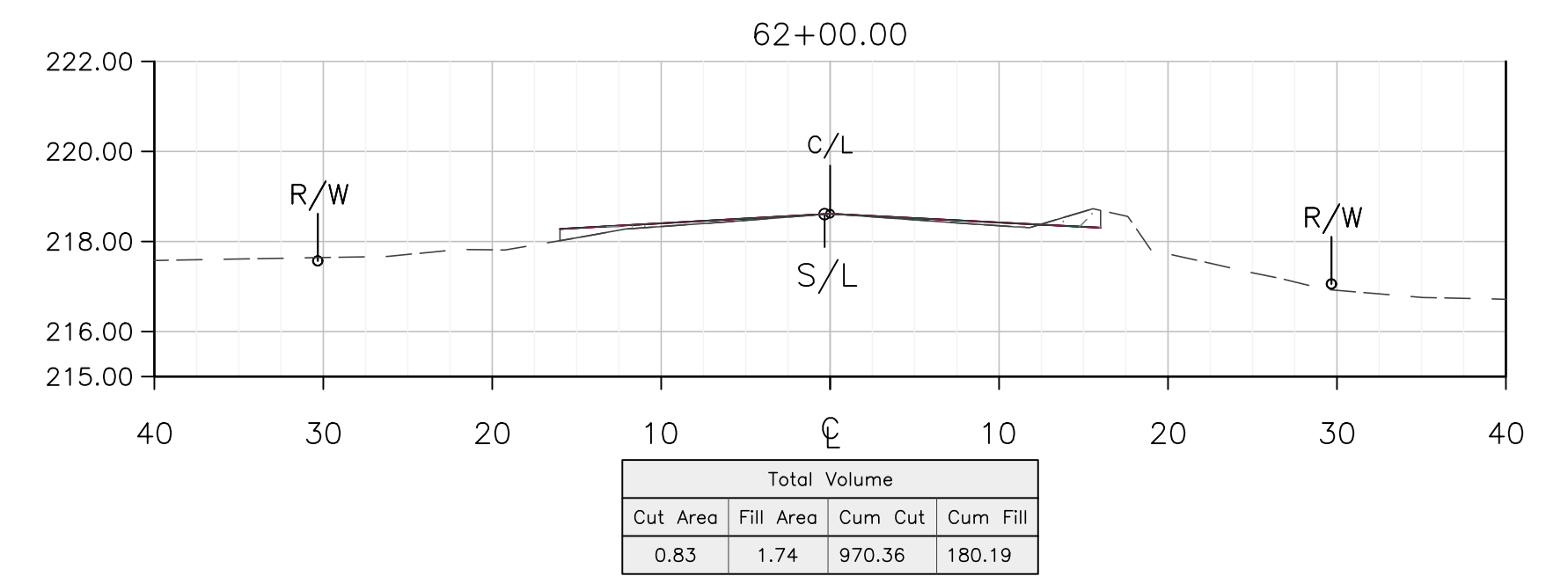
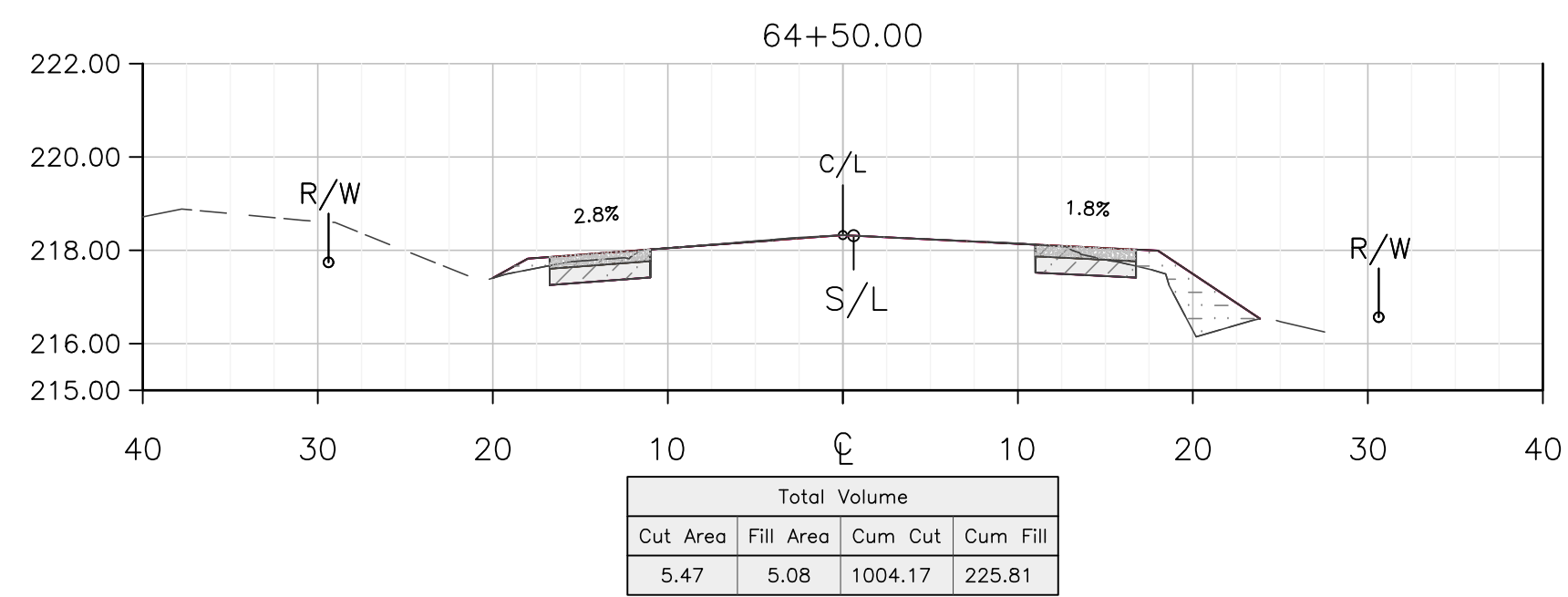
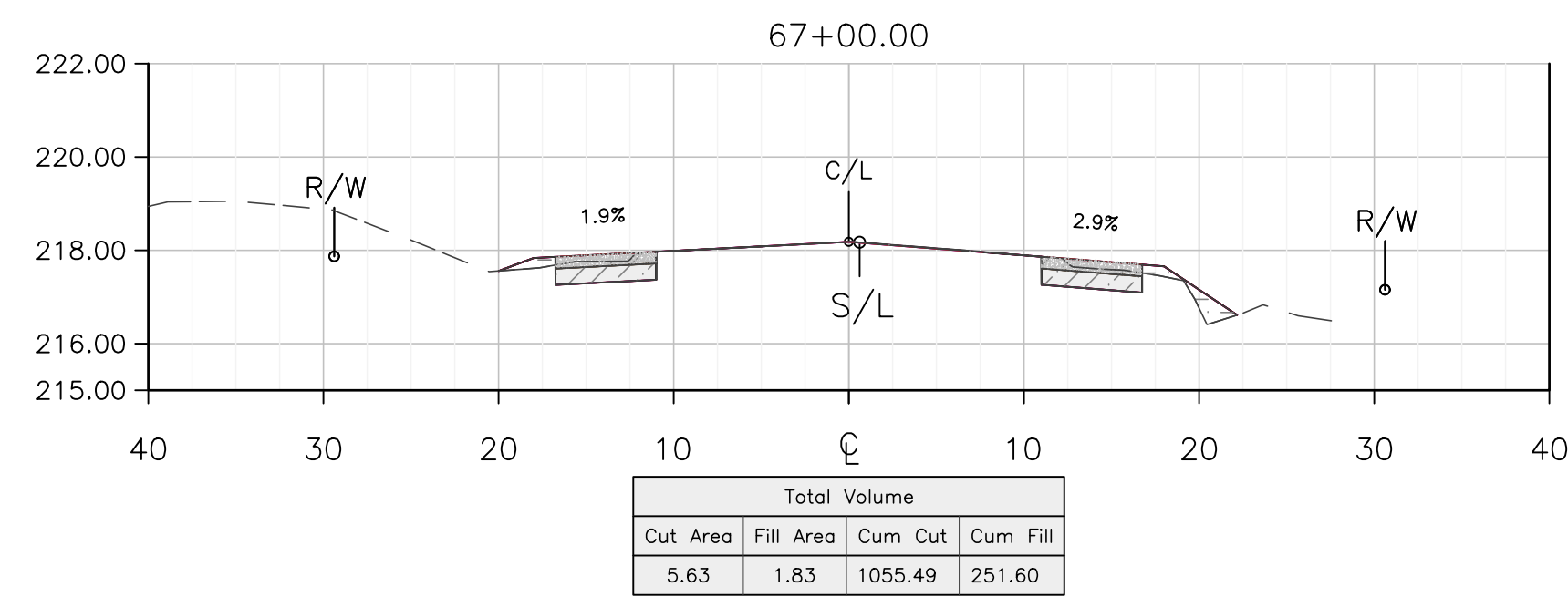
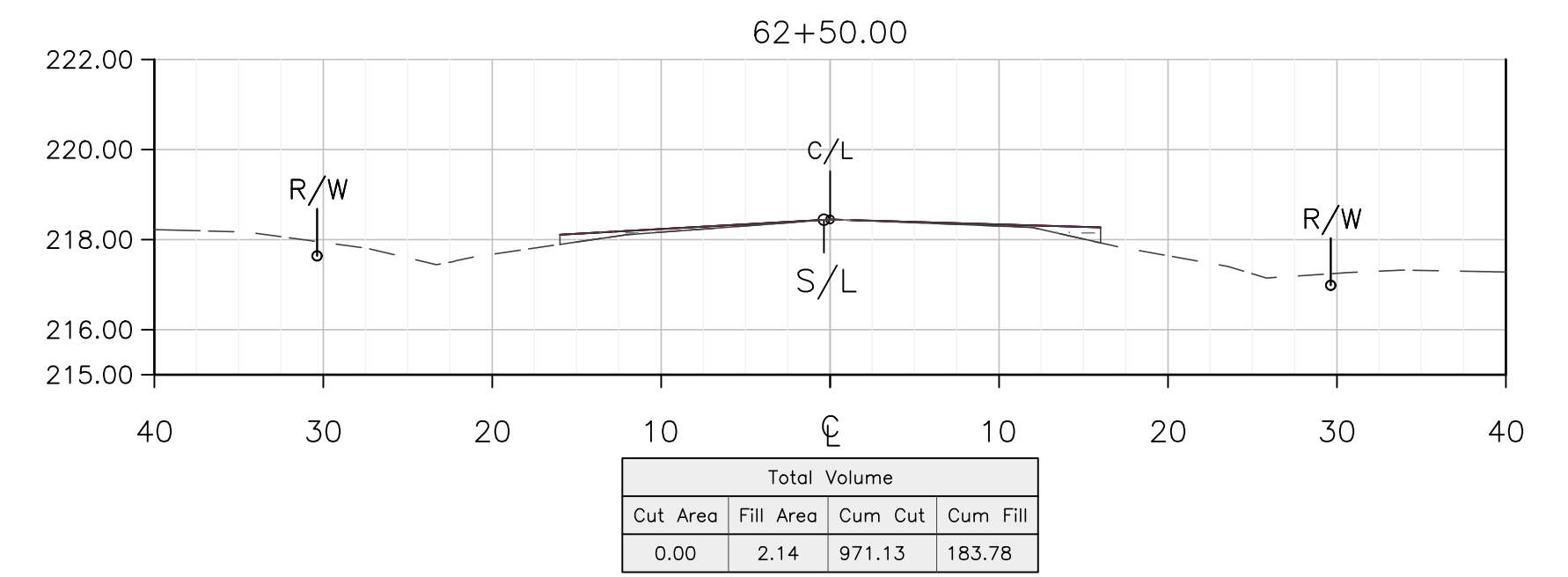
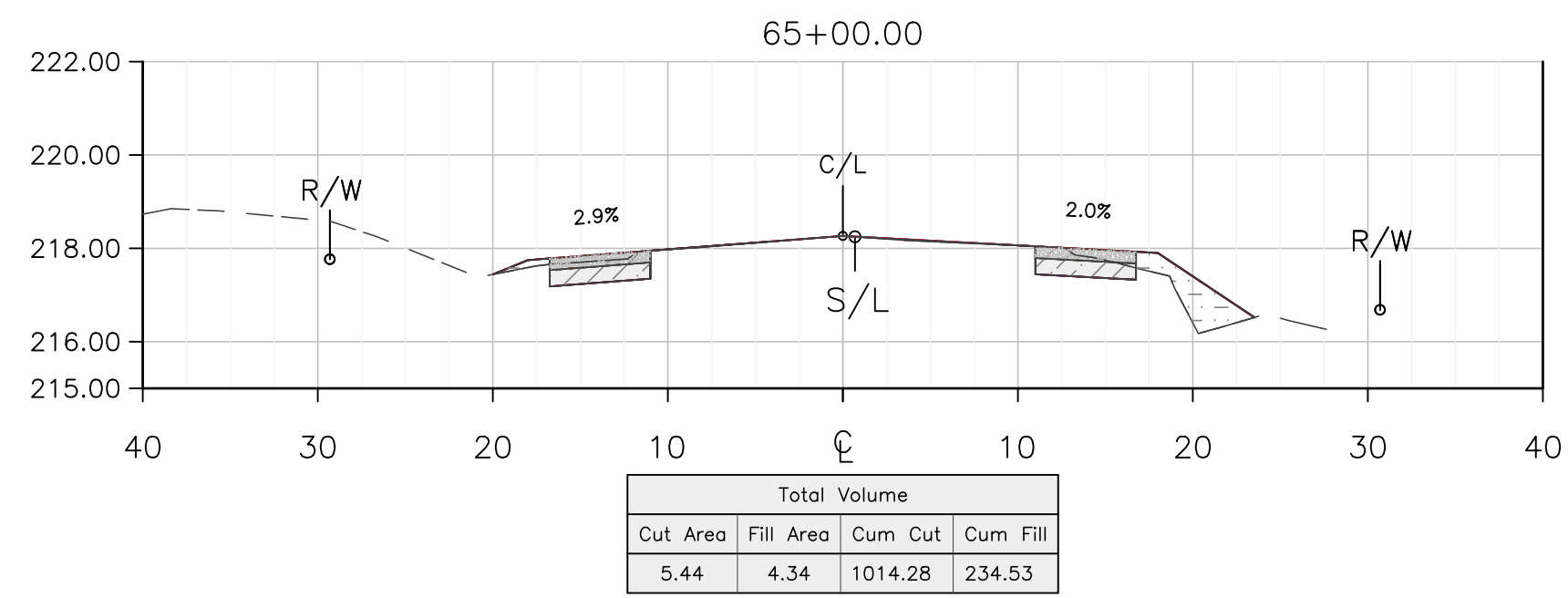
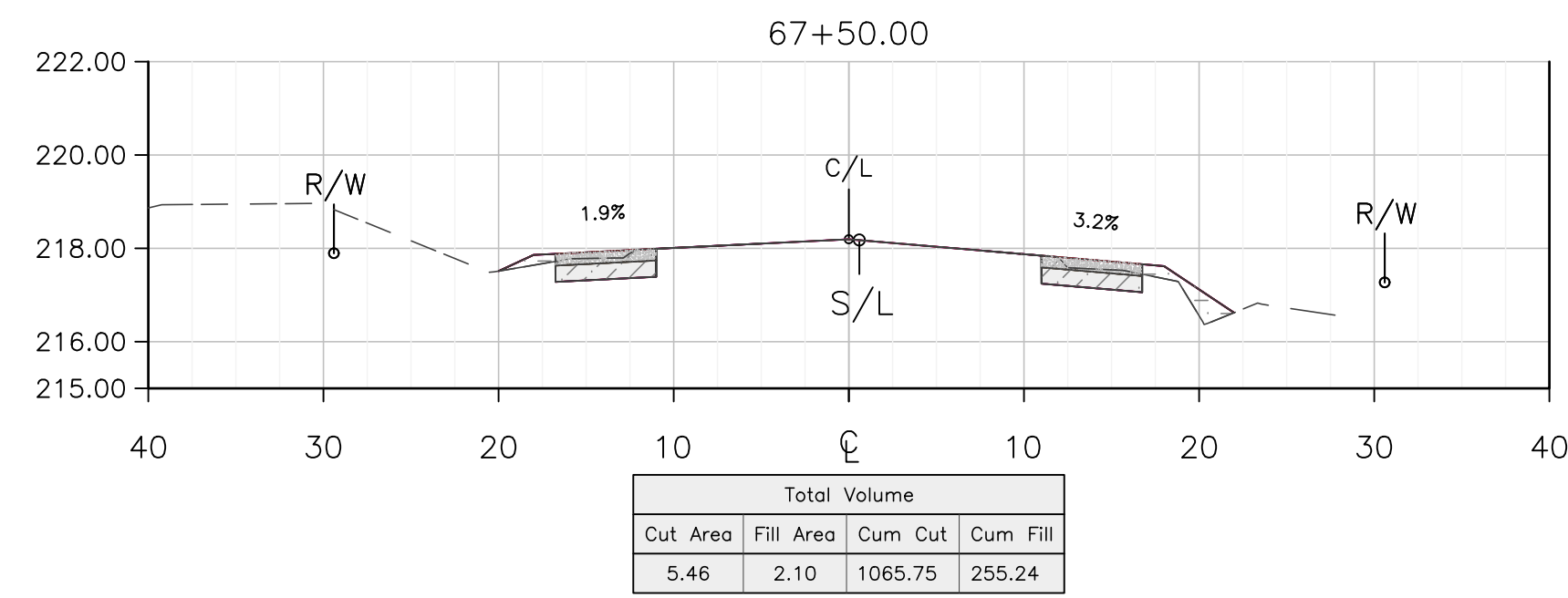
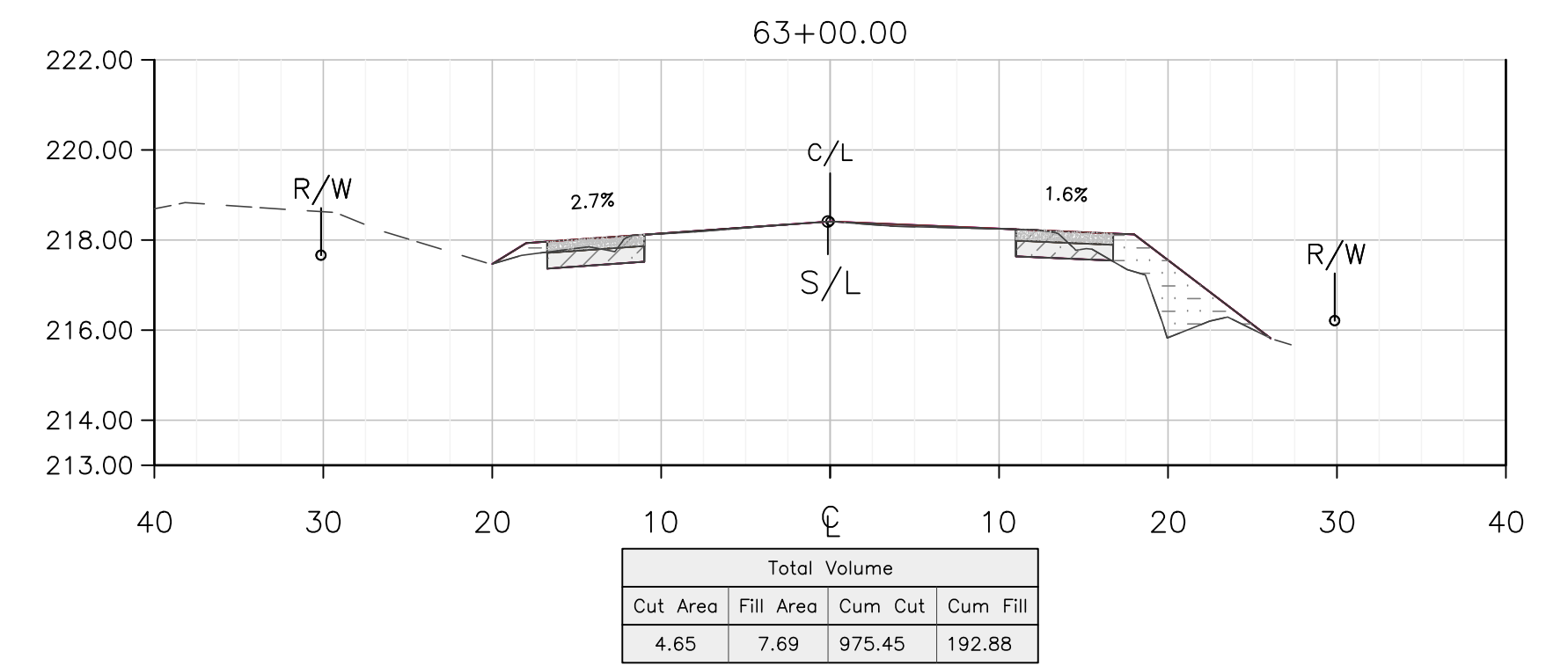
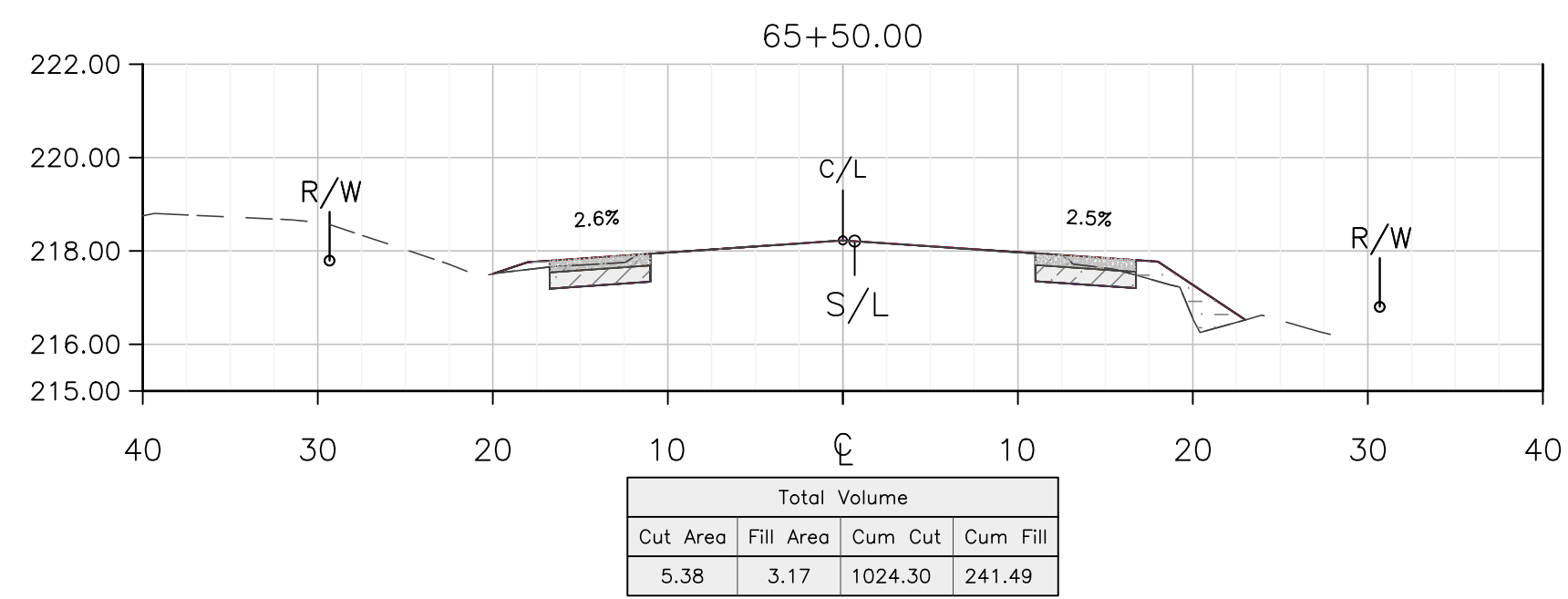
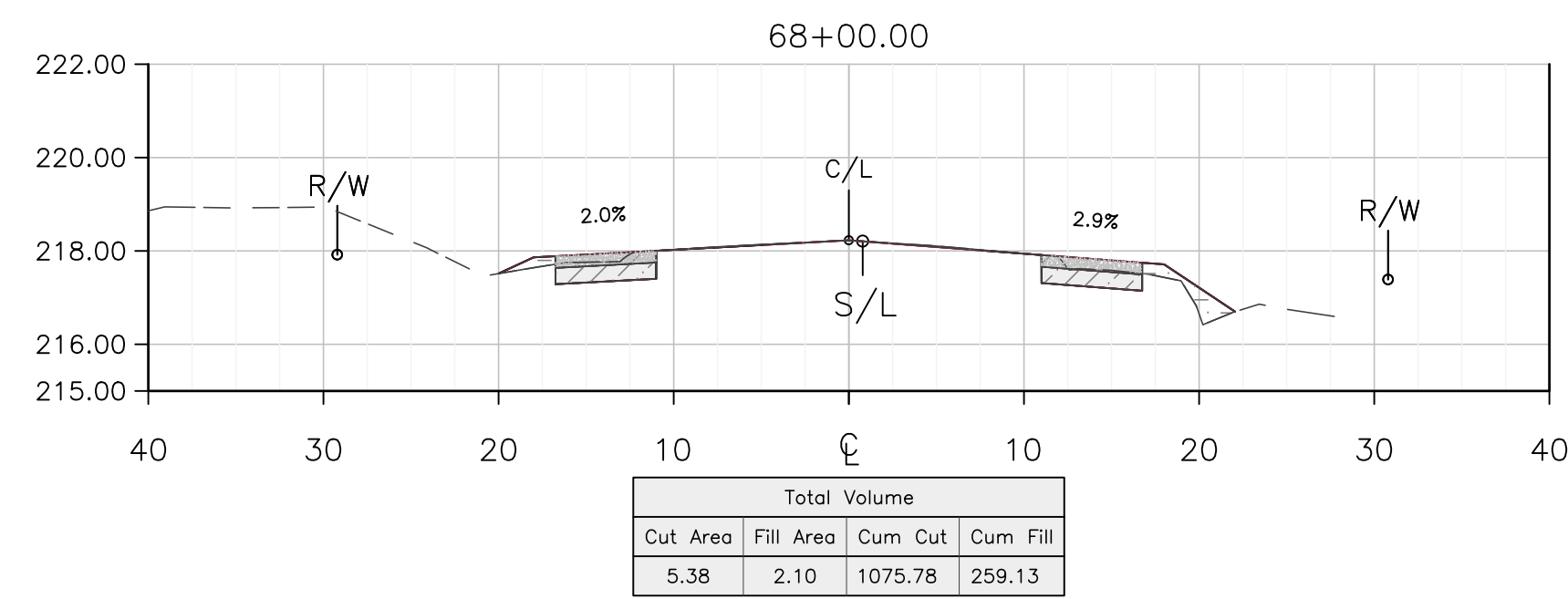
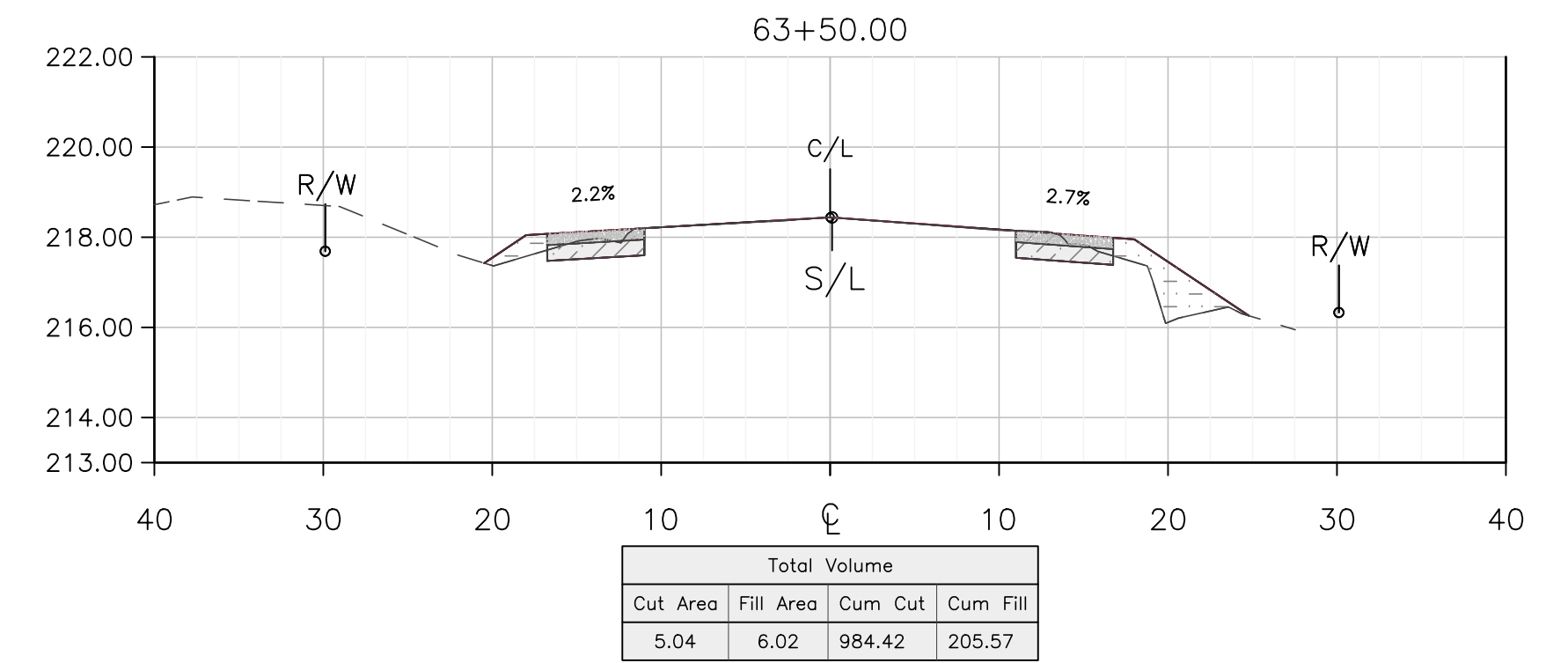
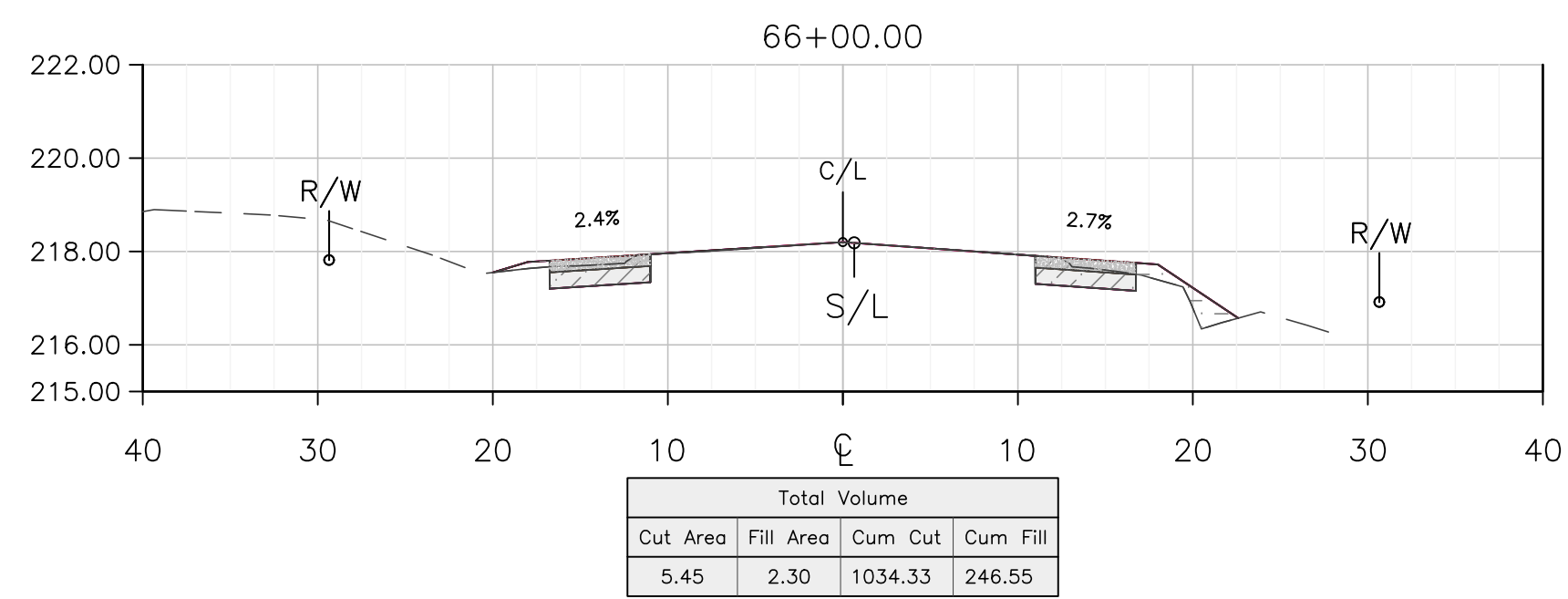
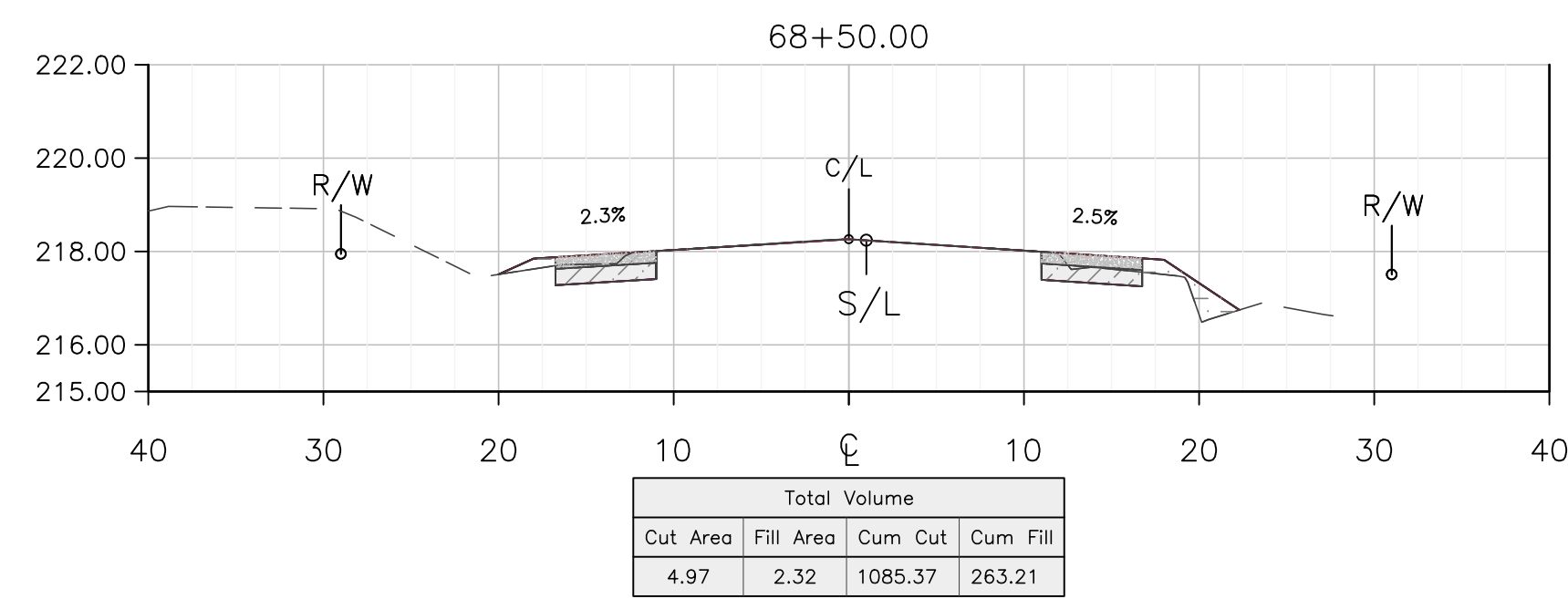
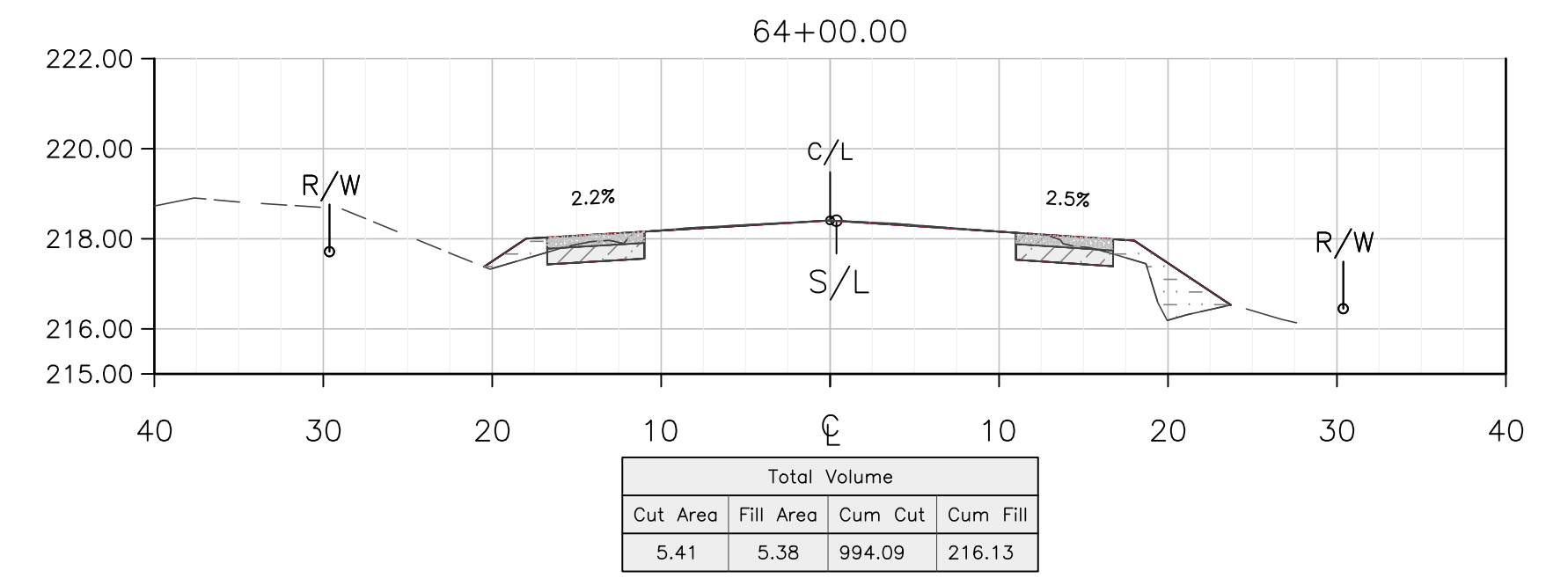
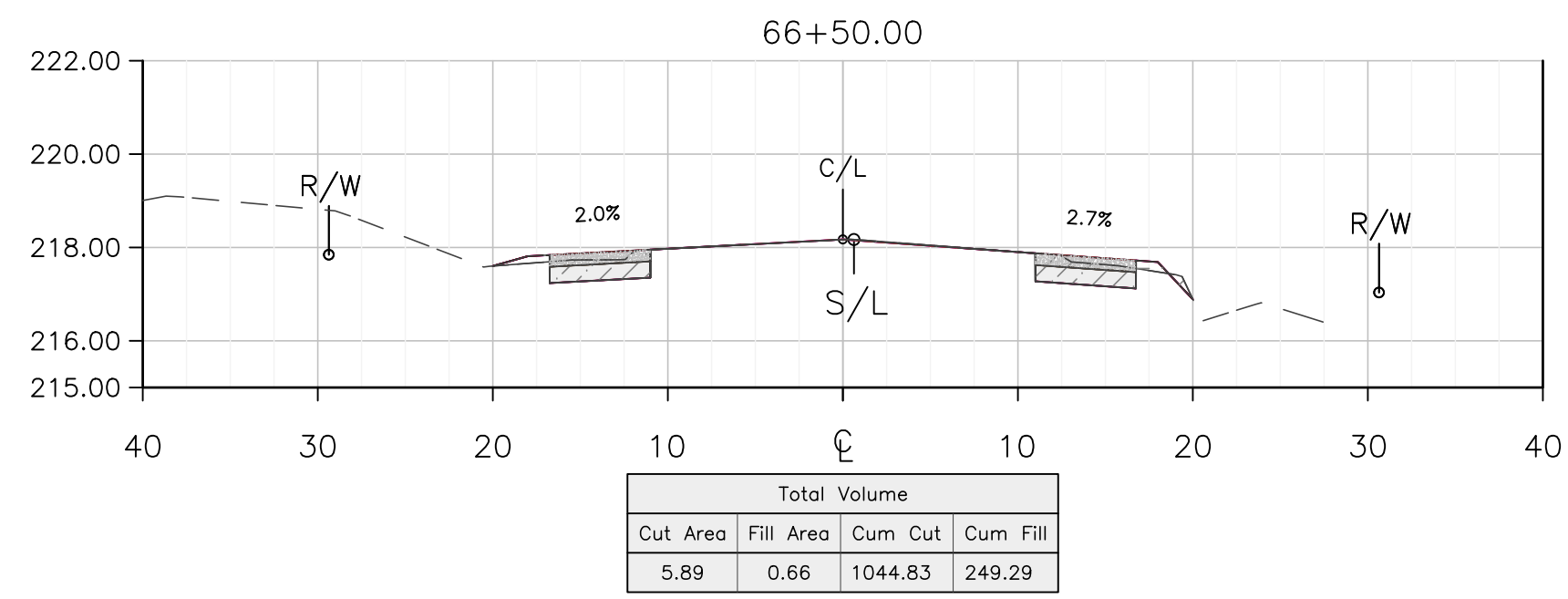
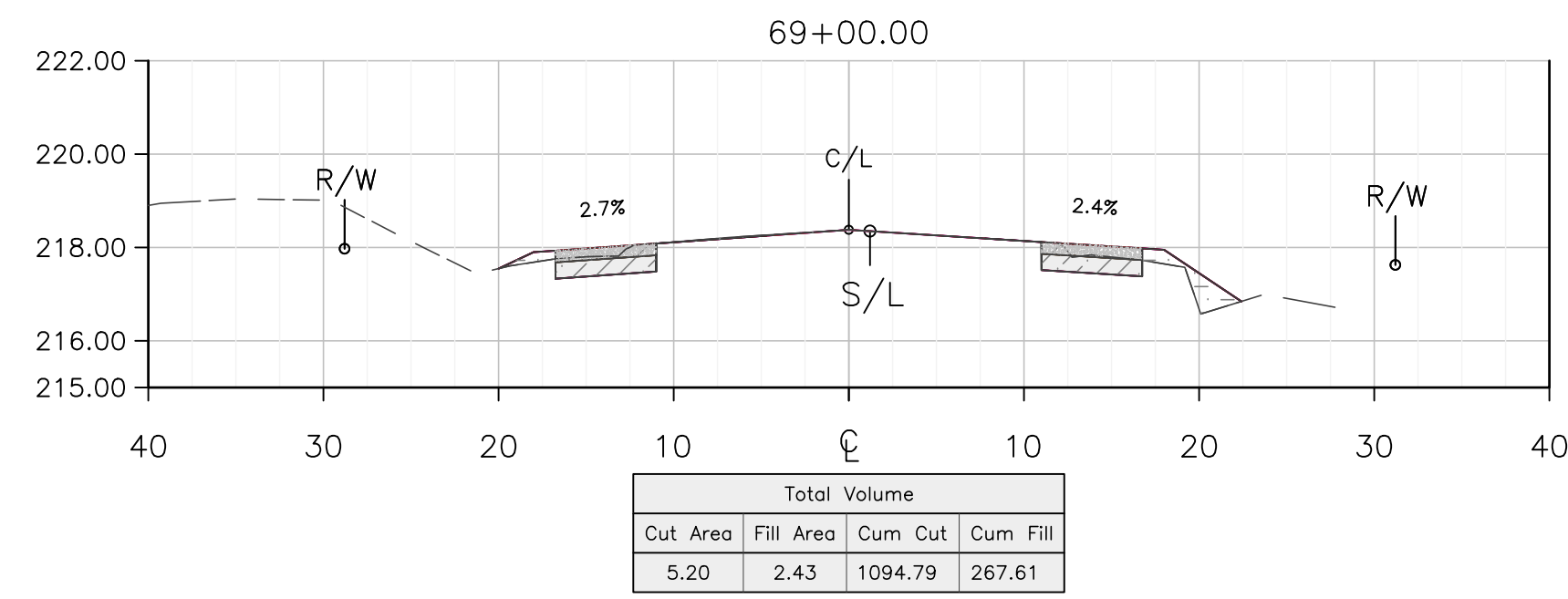

DEPARTMENT OF PUBLIC WORKS AND PLANNING

SHOULDER IMPROVEMENTS X-SECTIONS

PROJECT
JENSEN AVENUE SHOULDER IMPROVEMENTS & OVERLAY
MADERA AVE TO DICKINSON AVE

SCALE
10' = 1" (Horizontal)
20' HZ = 1" (Vertical)
2.5' = 1" (Shoulder)

DATE
2/2020
2/2020
2/2020

DESIGNED: B.KHALIQ
DRAWN: B.KHALIQ
CHECKED: S.ARTAL

ROAD NO. ## **BRIDGE NO. ##** **DRAWING NO. ##** **SHEET NO. CB** **TOTAL ###**

THESE CROSS SECTIONS ARE FOR THE CONTRACTOR'S INFORMATION ONLY. THEY ARE NOT TO BE CONSIDERED TO BE PART OF THE CONTRACT DOCUMENTS AND SHALL HAVE NO BEARING WHATSOEVER ON THE INTERPRETATION OF THE STANDARD SPECIFICATIONS, THE STANDARD PLANS, THE SPECIAL PROVISIONS, NOR SHALL THEY HAVE ANY BEARING WHATSOEVER ON THE INTERPRETATION OF THE OTHER PUBLICATIONS REFERENCED THEREIN.

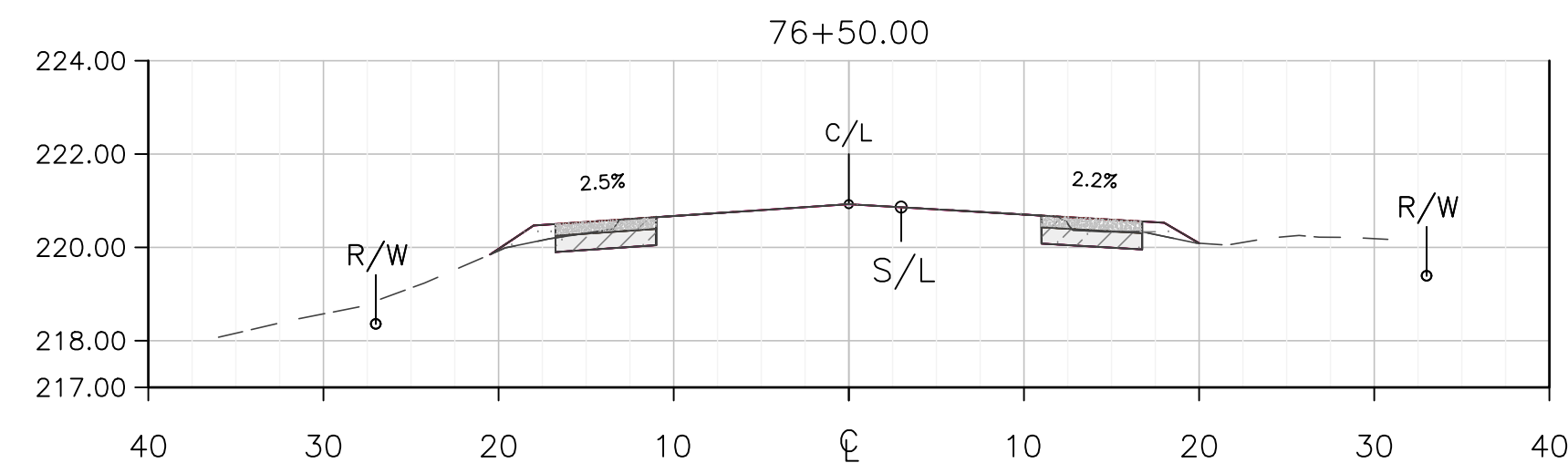

Total Volume			
Cut Area	Fill Area	Cum Cut	Cum Fill
4.97	1.42	1236.73	398.10

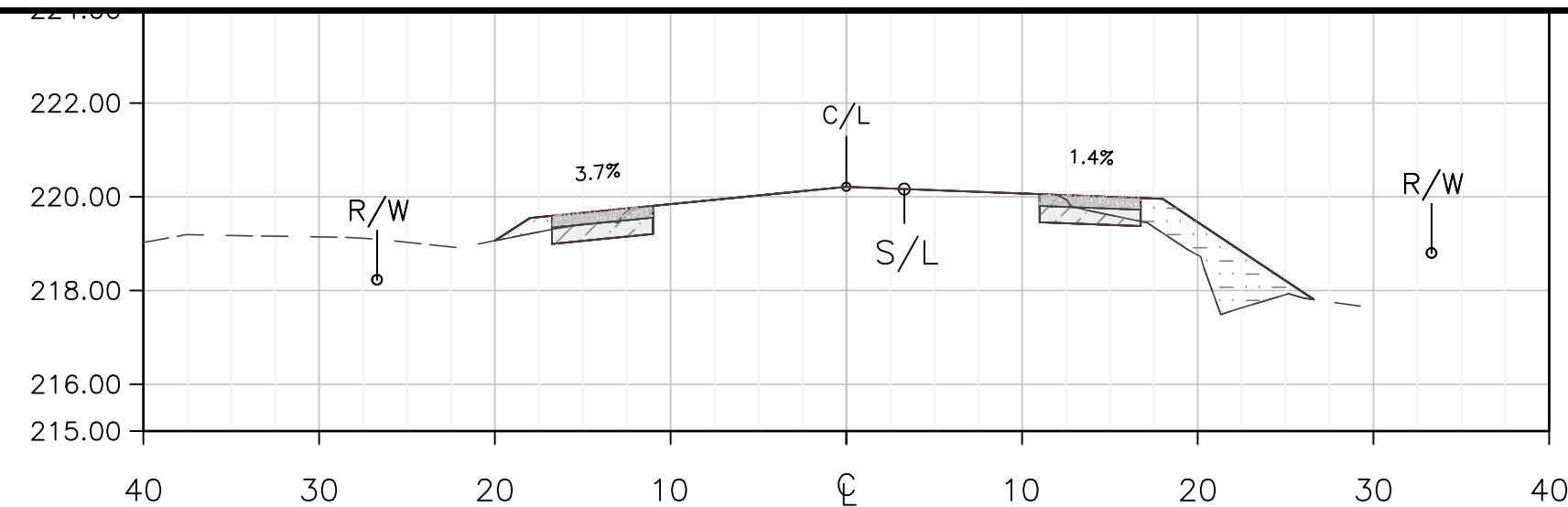

Total Volume			
Cut Area	Fill Area	Cum Cut	Cum Fill
4.35	8.20	1191.06	352.29

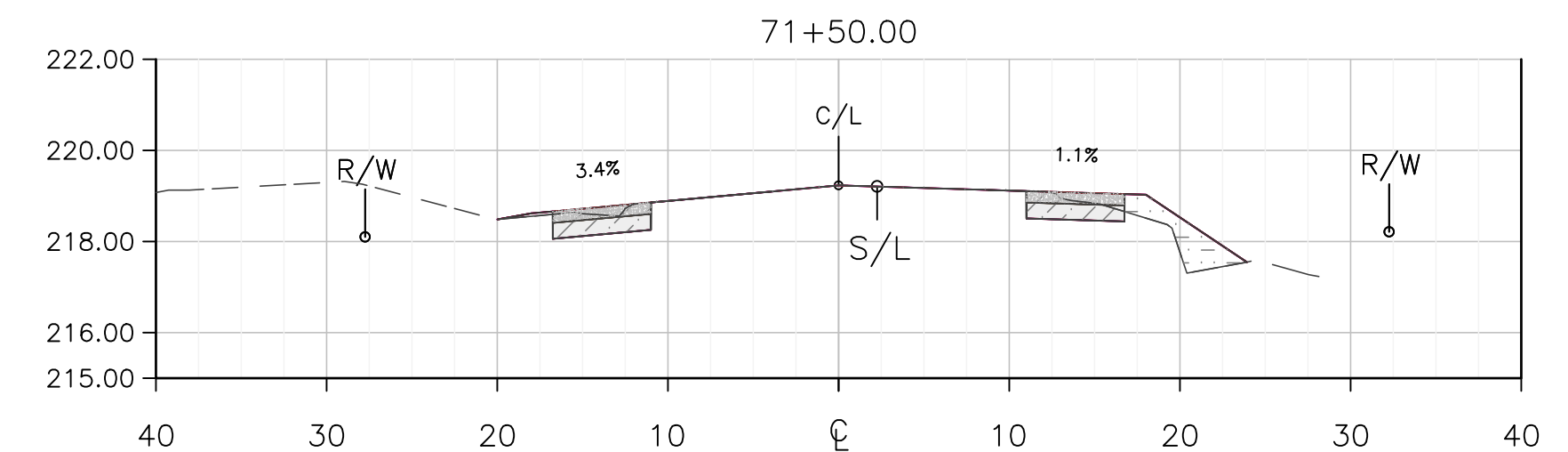

Total Volume			
Cut Area	Fill Area	Cum Cut	Cum Fill
5.43	3.96	1145.65	295.97

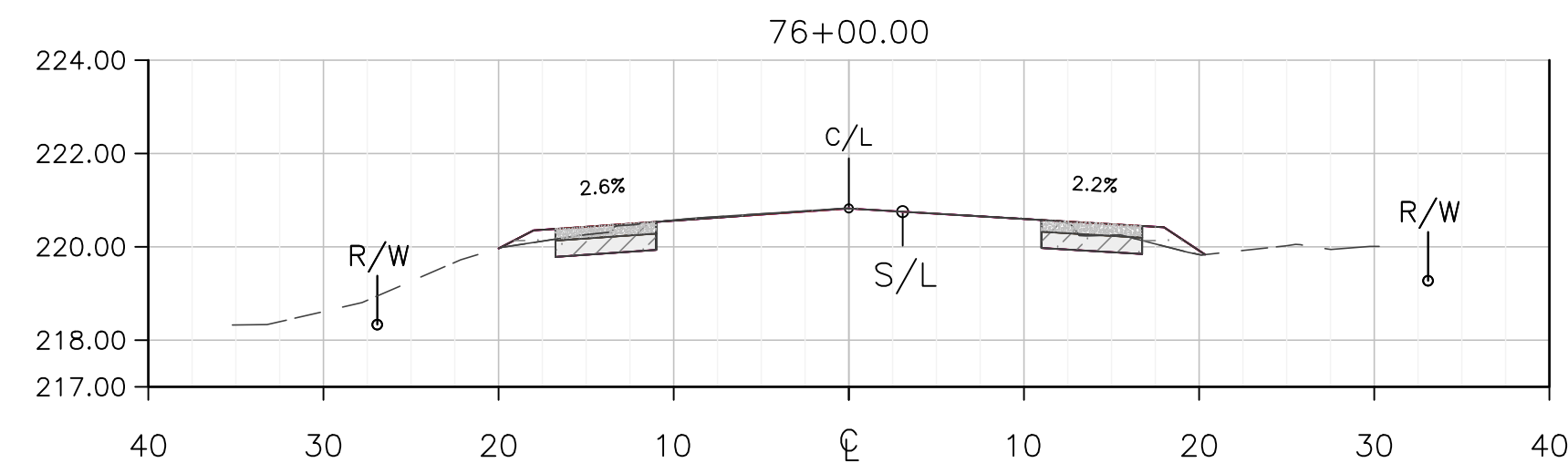

Total Volume			
Cut Area	Fill Area	Cum Cut	Cum Fill
5.37	1.51	1227.15	395.38

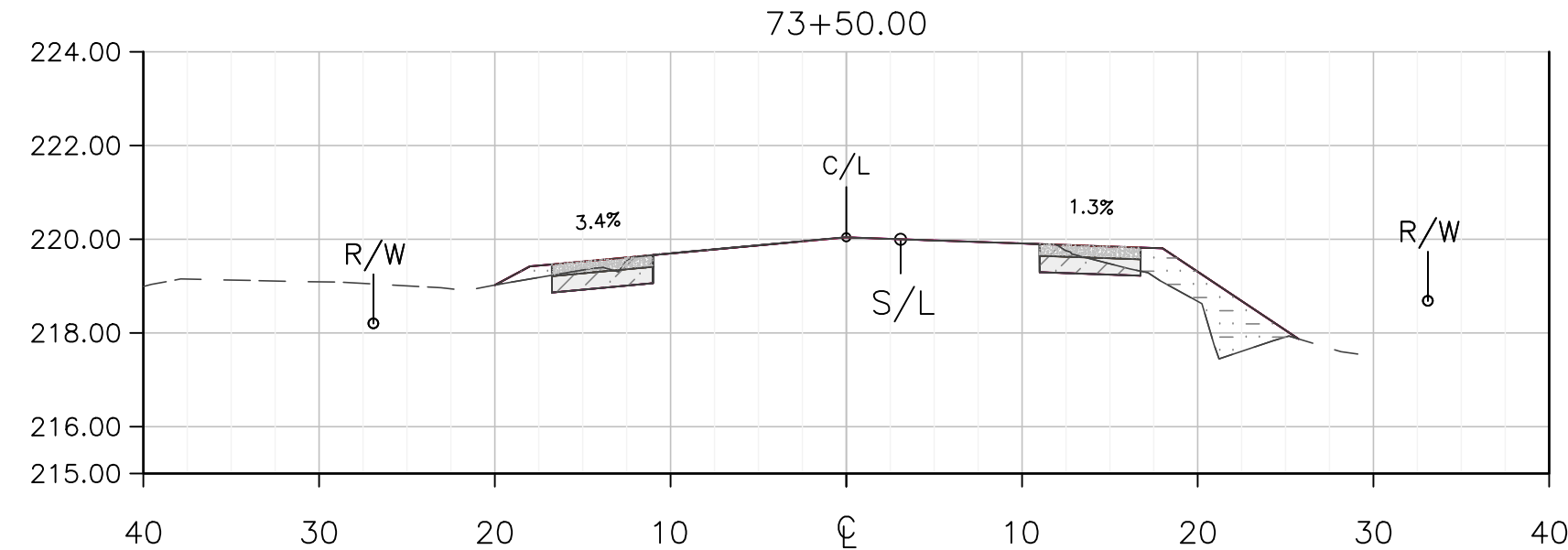

Total Volume			
Cut Area	Fill Area	Cum Cut	Cum Fill
4.64	7.17	1182.73	338.06

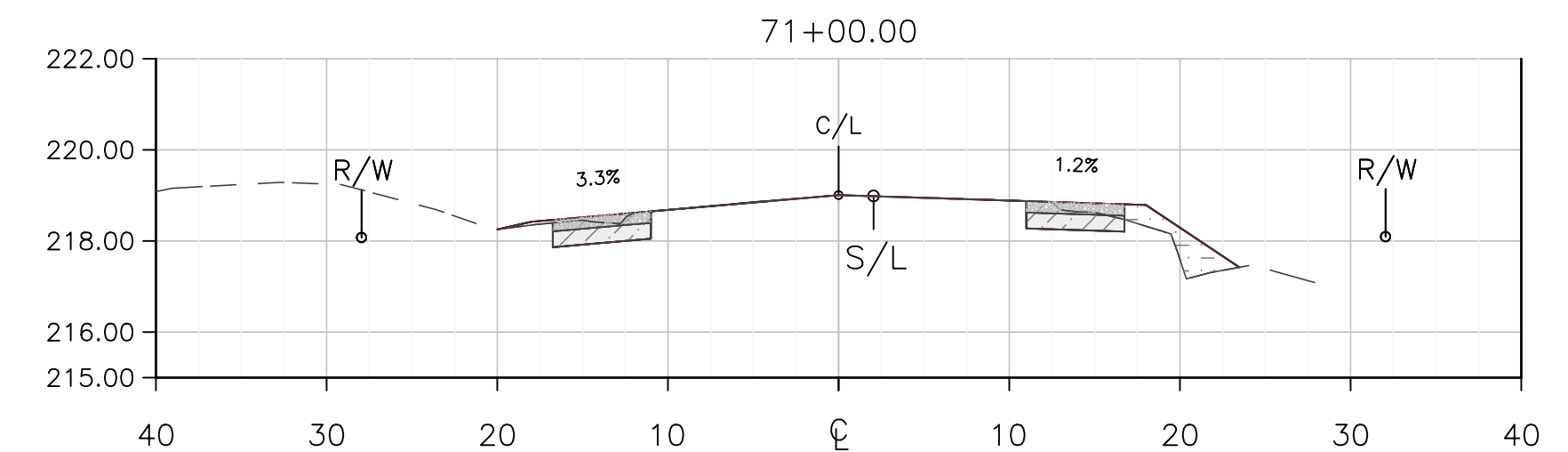

Total Volume			
Cut Area	Fill Area	Cum Cut	Cum Fill
5.63	3.35	1135.41	289.21

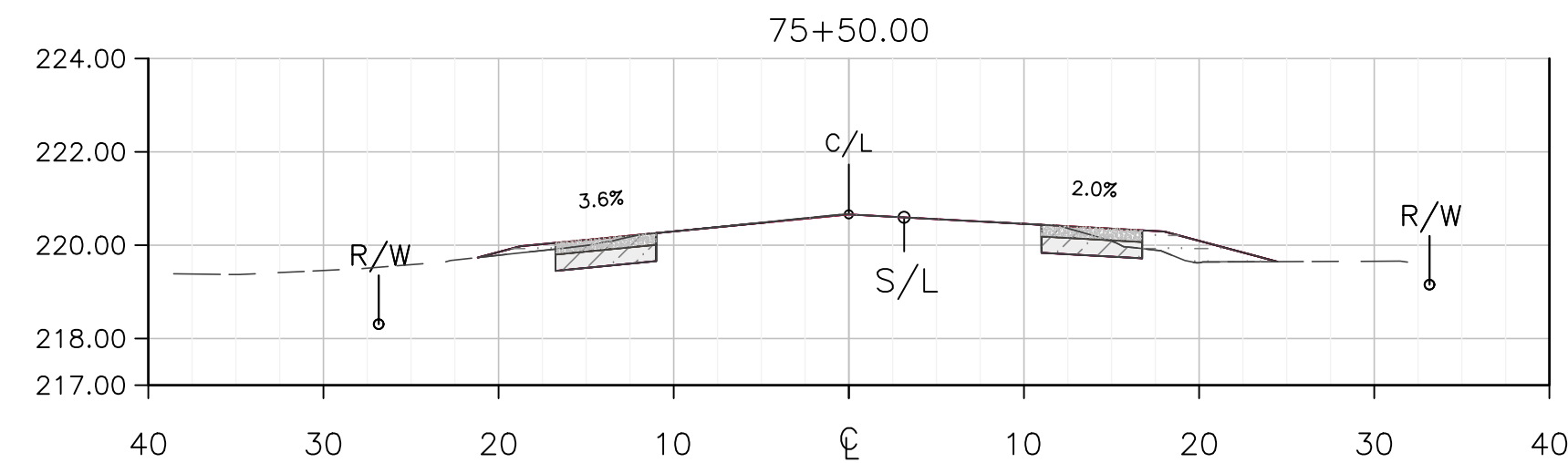

Total Volume			
Cut Area	Fill Area	Cum Cut	Cum Fill
5.53	2.94	1217.05	391.26

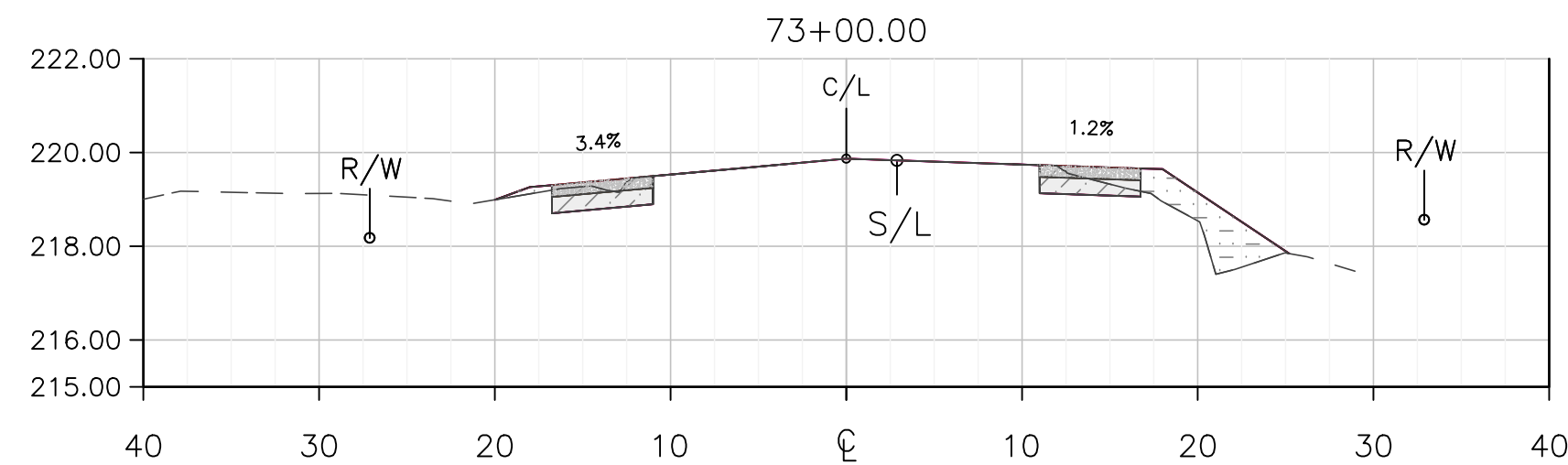

Total Volume			
Cut Area	Fill Area	Cum Cut	Cum Fill
4.89	6.39	1173.91	325.50

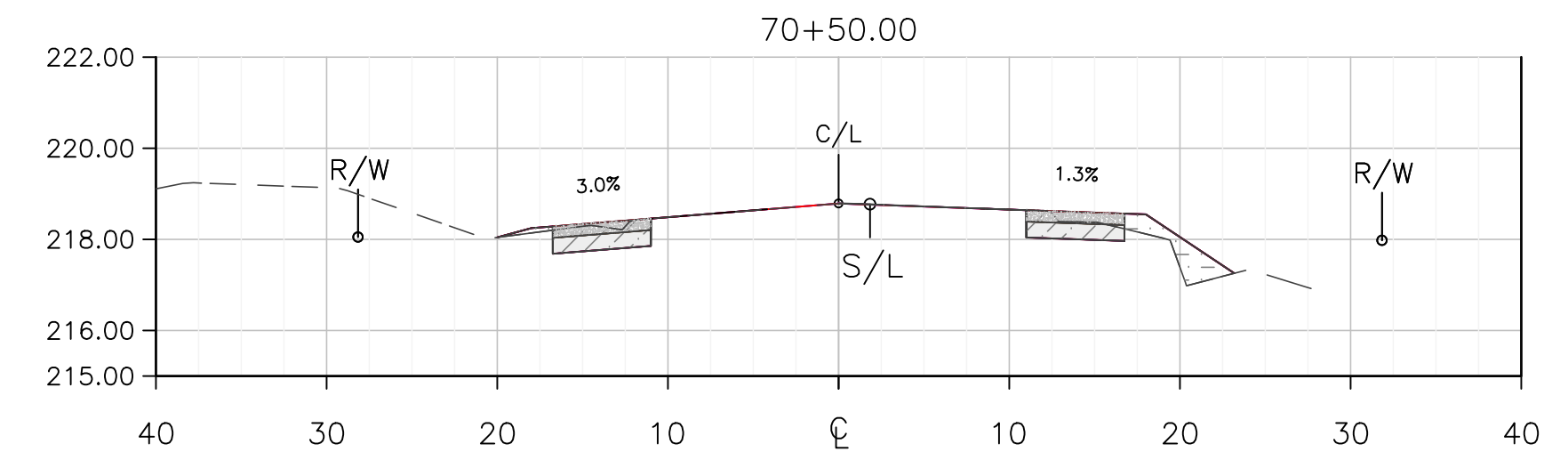

Total Volume			
Cut Area	Fill Area	Cum Cut	Cum Fill
5.55	3.08	1125.06	283.26

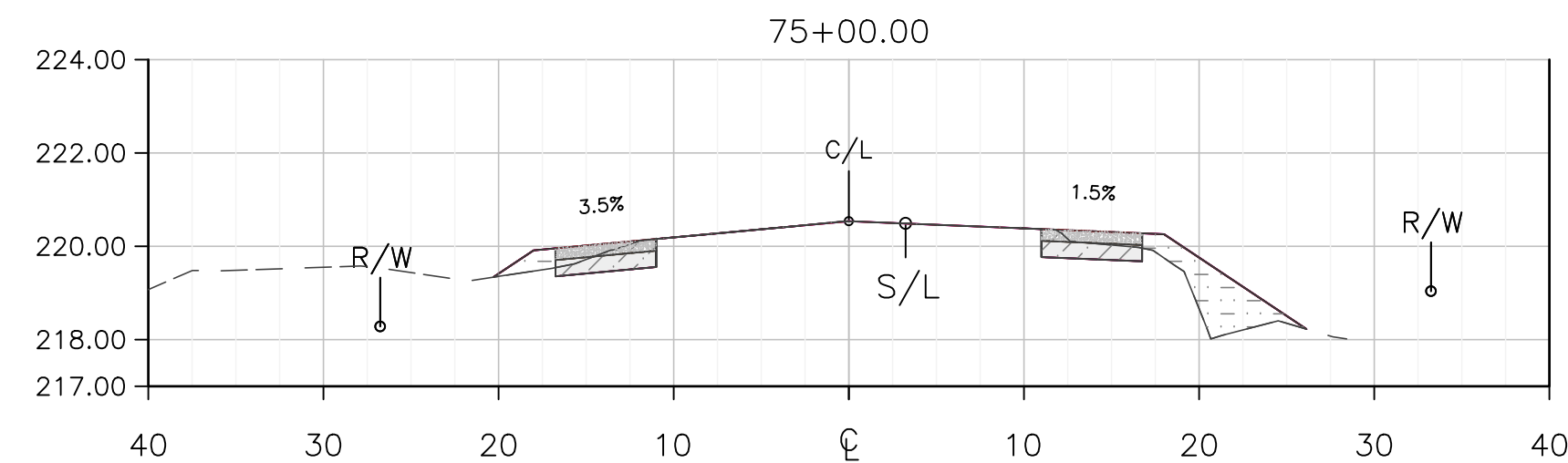

Total Volume			
Cut Area	Fill Area	Cum Cut	Cum Fill
4.63	7.33	1207.64	381.75

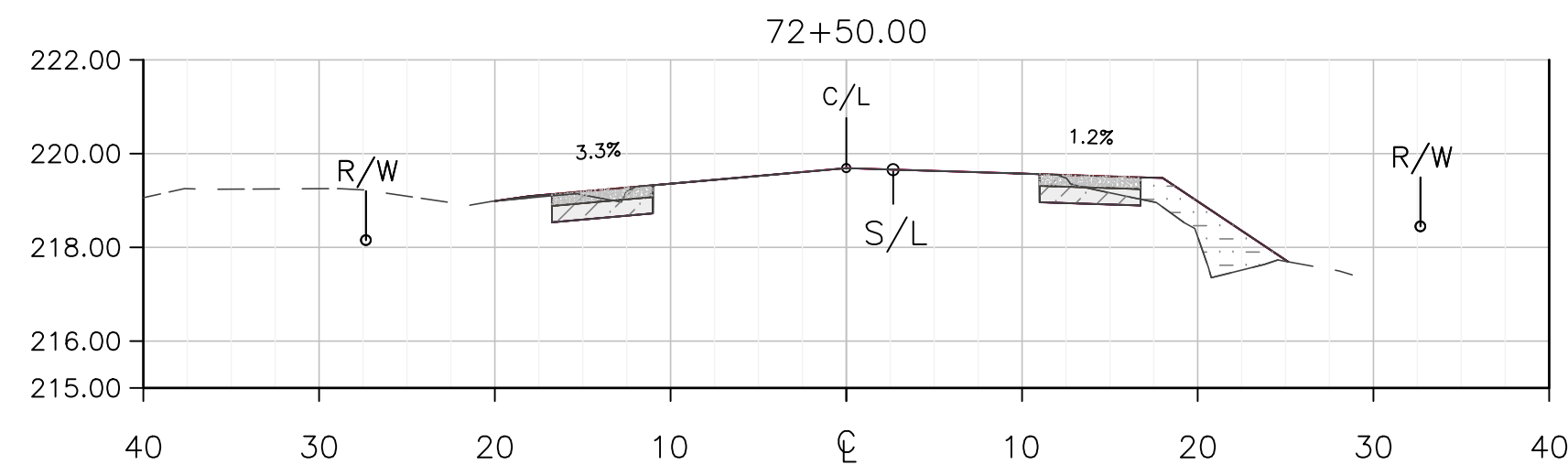

Total Volume			
Cut Area	Fill Area	Cum Cut	Cum Fill
4.97	5.85	1164.78	314.17

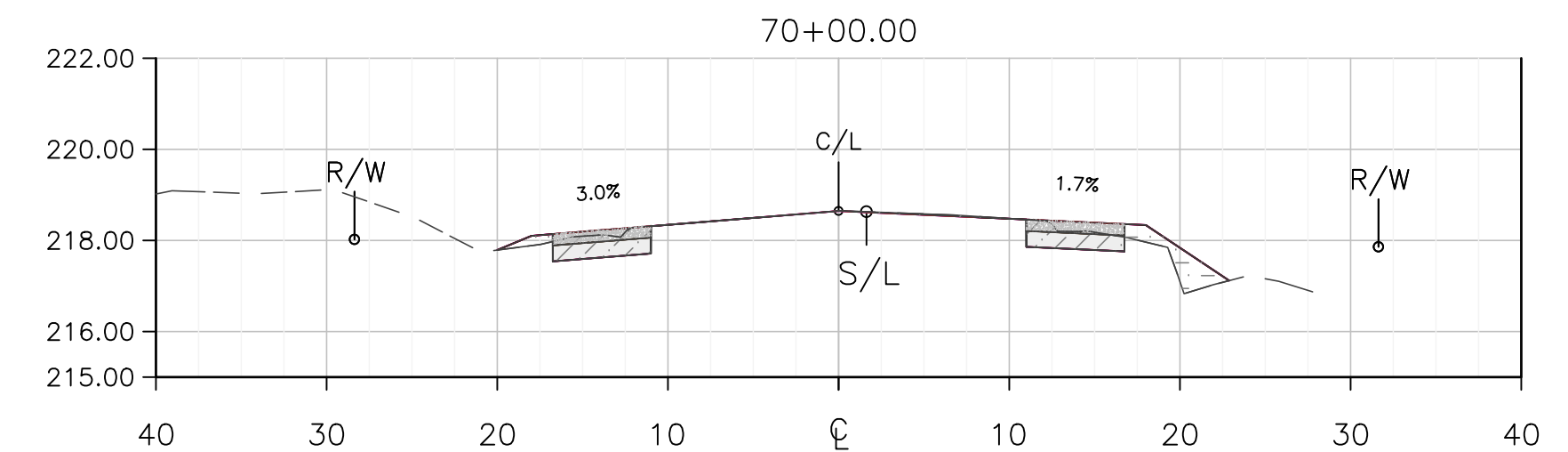

Total Volume			
Cut Area	Fill Area	Cum Cut	Cum Fill
5.58	3.00	1114.75	277.63

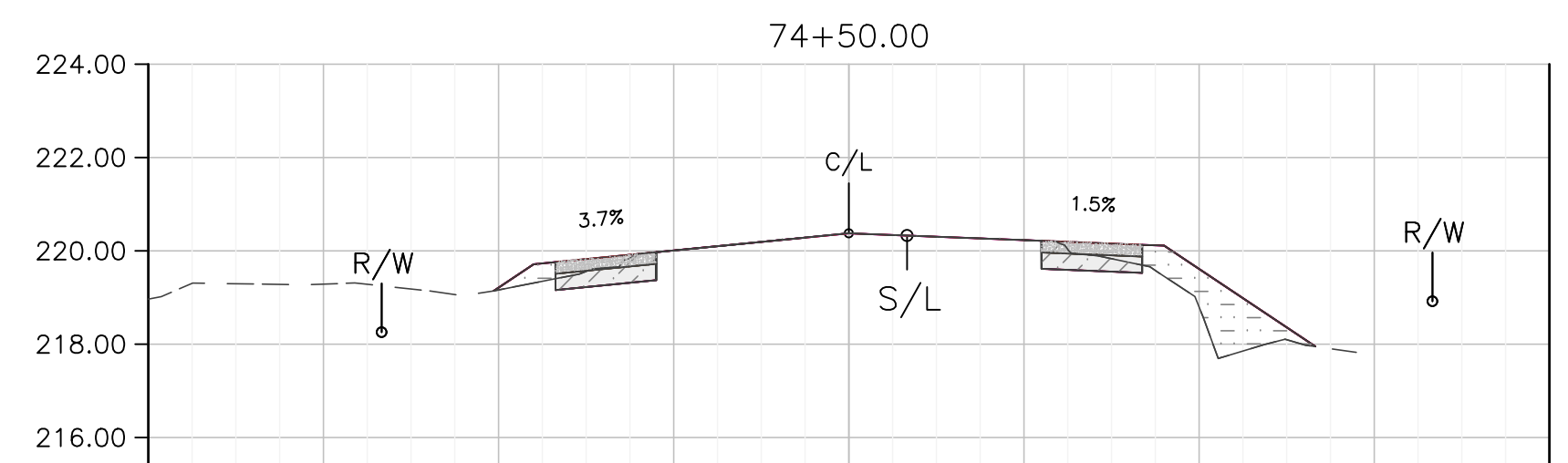

Total Volume			
Cut Area	Fill Area	Cum Cut	Cum Fill
4.46	8.15	1199.22	367.42

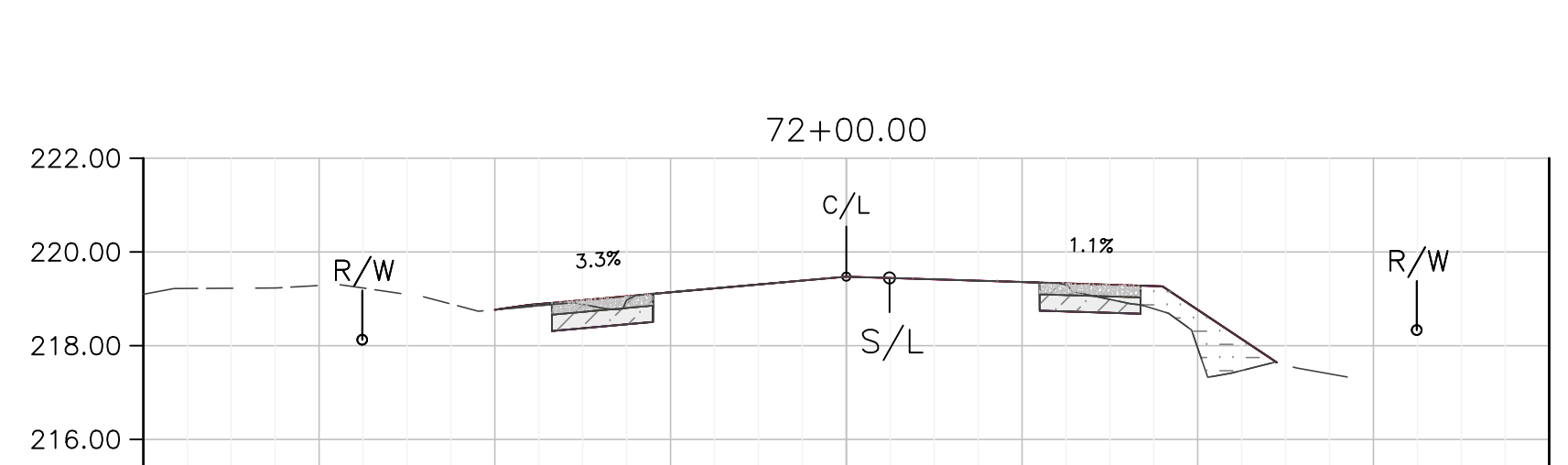

Total Volume			
Cut Area	Fill Area	Cum Cut	Cum Fill
5.13	4.92	1155.43	304.19

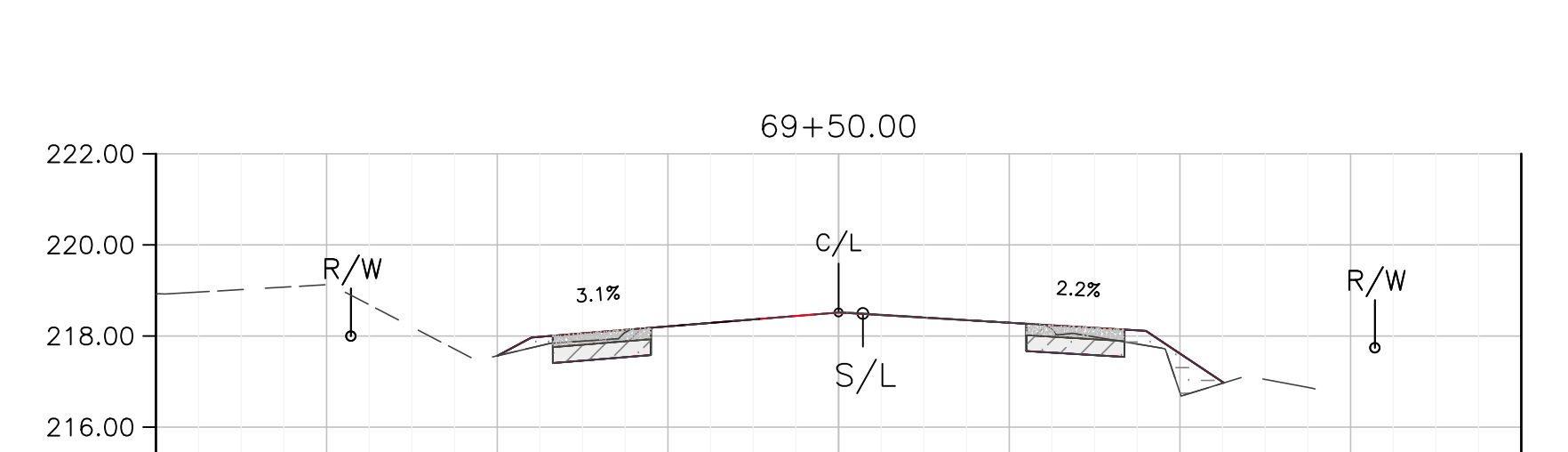

Total Volume			
Cut Area	Fill Area	Cum Cut	Cum Fill
5.39	2.69	1104.59	272.36

DEPARTMENT OF PUBLIC WORKS AND PLANNING

SHOULDER IMPROVEMENTS X-SECTIONS

PROJECT
JENSEN AVENUE SHOULDER IMPROVEMENTS & OVERLAY
MADERA AVE TO DICKINSON AVE

SCALE
10' = 20' HZ
2.5" = 5.0' VT

DATE	DESIGNED: B.KHALIQ	DRAWN: B.KHALIQ	CHECKED: S.ARTAL
2/2020			
2/2020			
2/2020			

ROAD NO. ###
BRIDGE NO. ###
SHEET NO. C8
TOTAL ###

THESE CROSS SECTIONS ARE FOR THE CONTRACTOR'S INFORMATION ONLY. THEY ARE NOT TO BE CONSIDERED TO BE PART OF THE CONTRACT DOCUMENTS AND SHALL HAVE NO BEARING WHATSOEVER ON THE INTERPRETATION OF THE STANDARD SPECIFICATIONS, THE STANDARD PLANS, THE SPECIAL PROVISIONS, NOR SHALL THEY HAVE ANY BEARING WHATSOEVER ON THE INTERPRETATION OF THE OTHER PUBLICATIONS REFERENCED THEREIN.

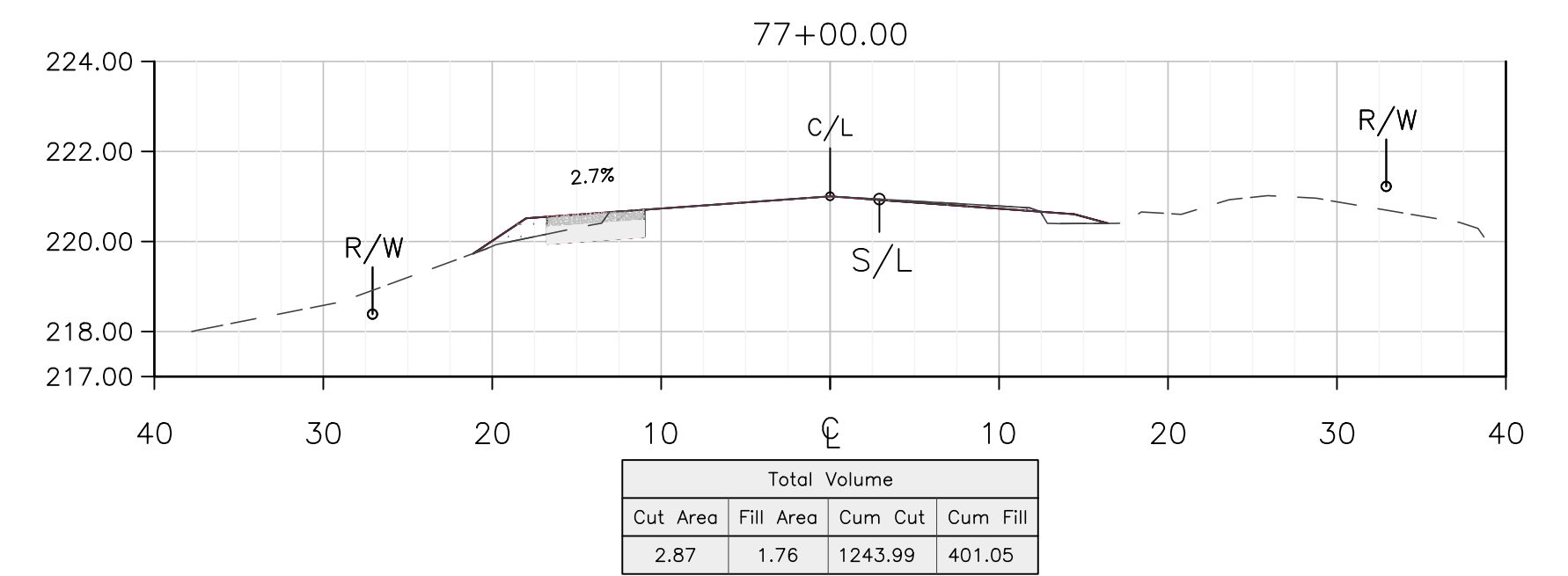
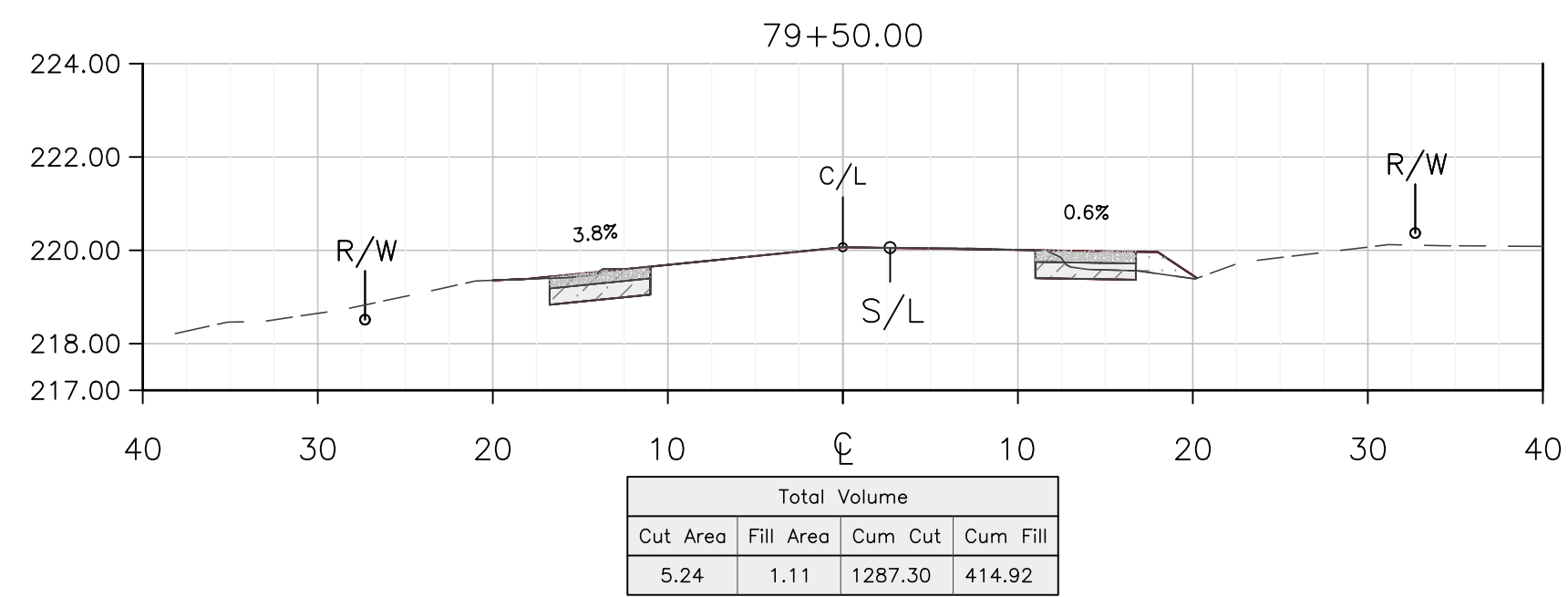
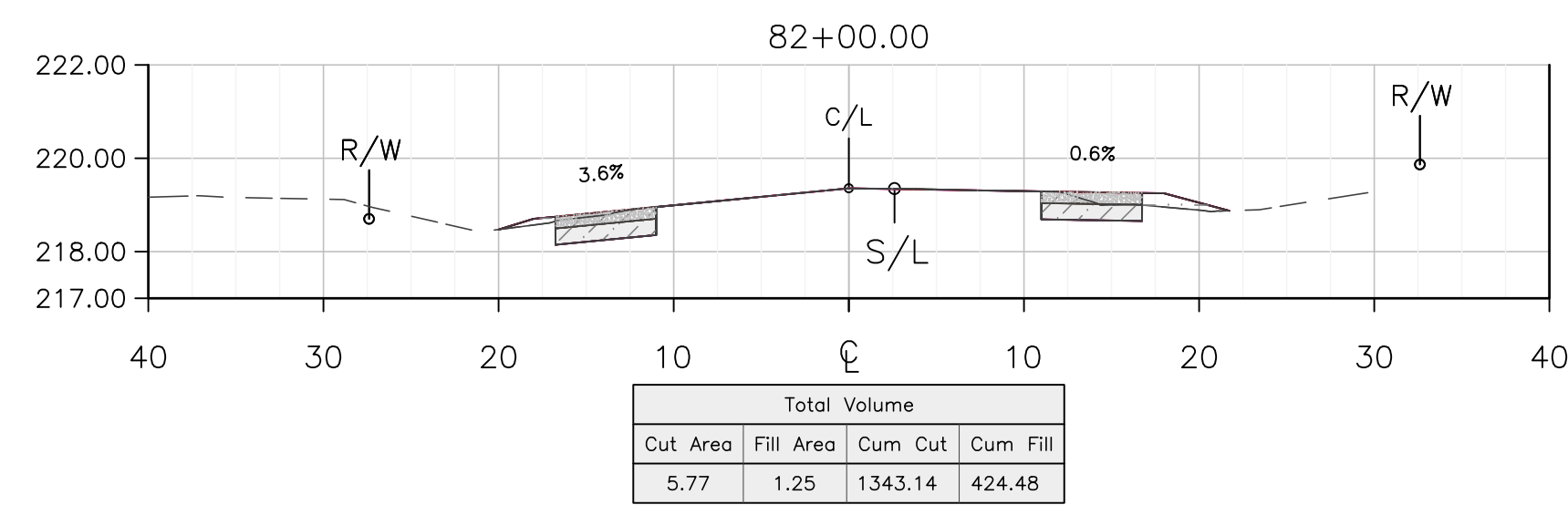
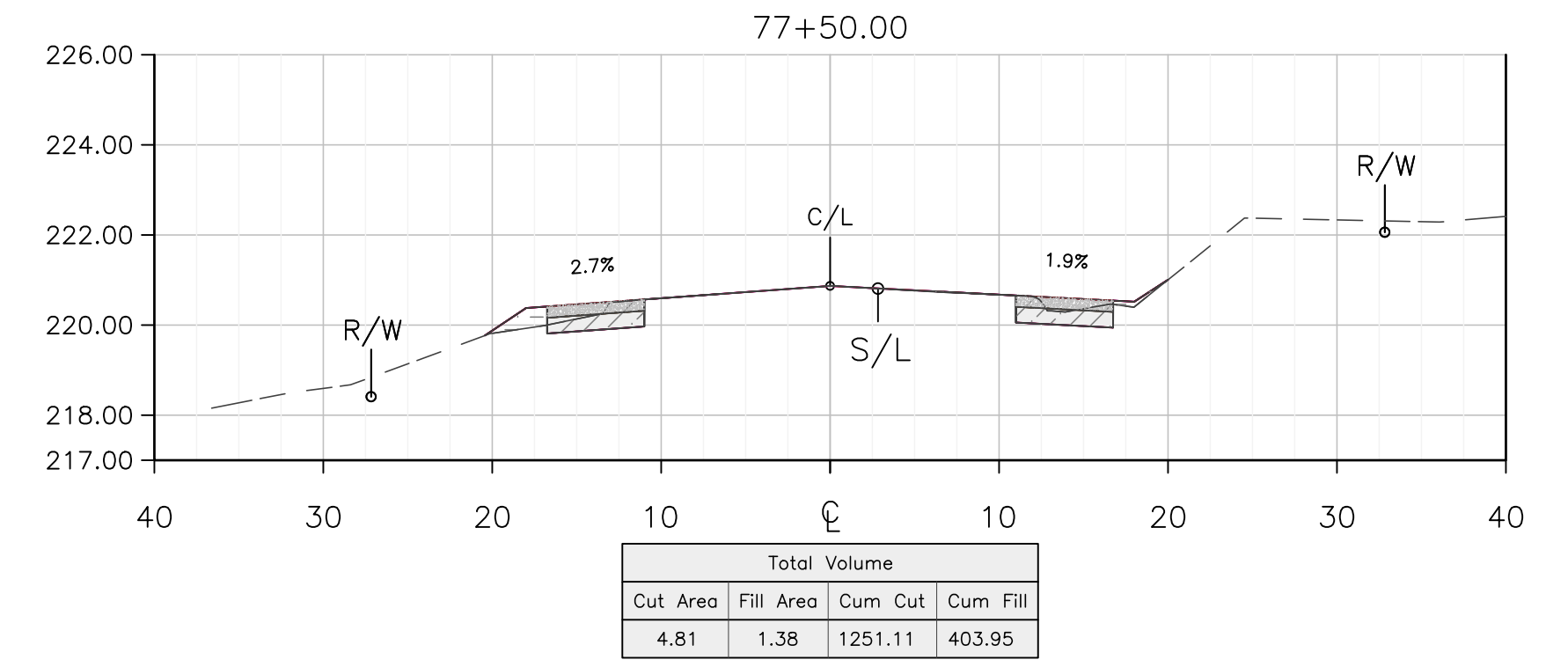
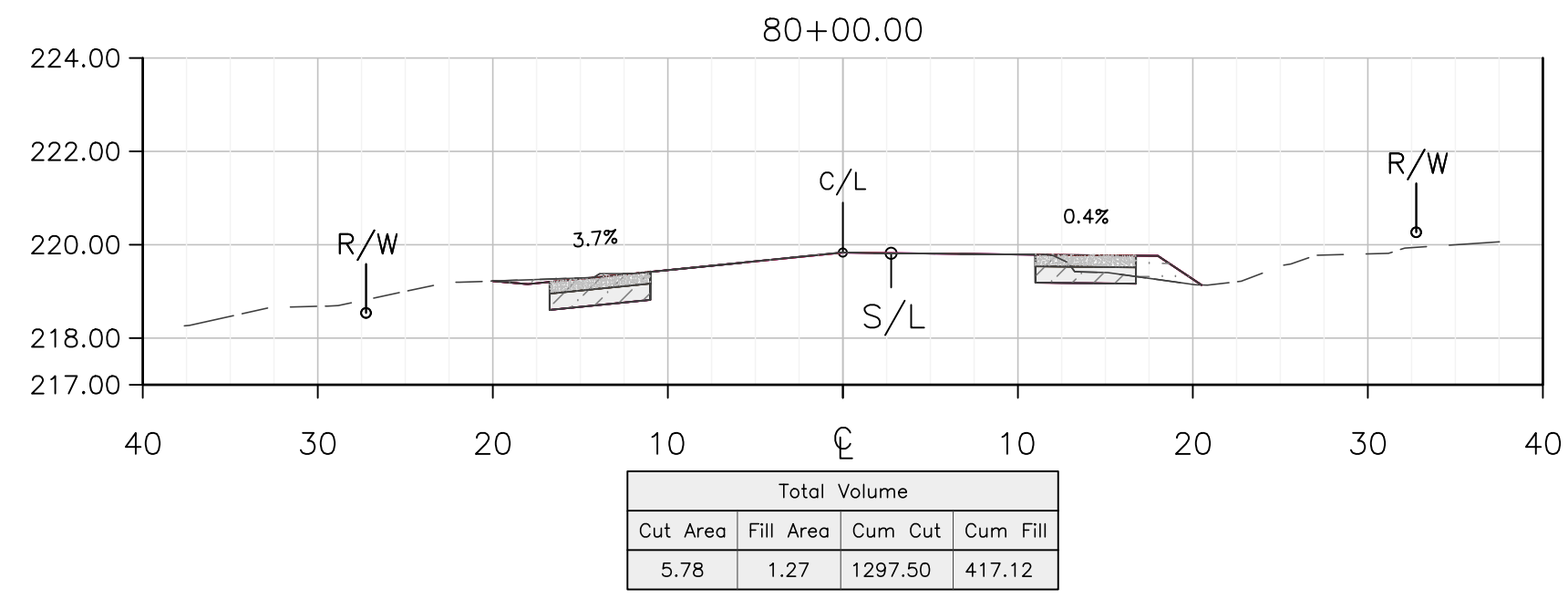
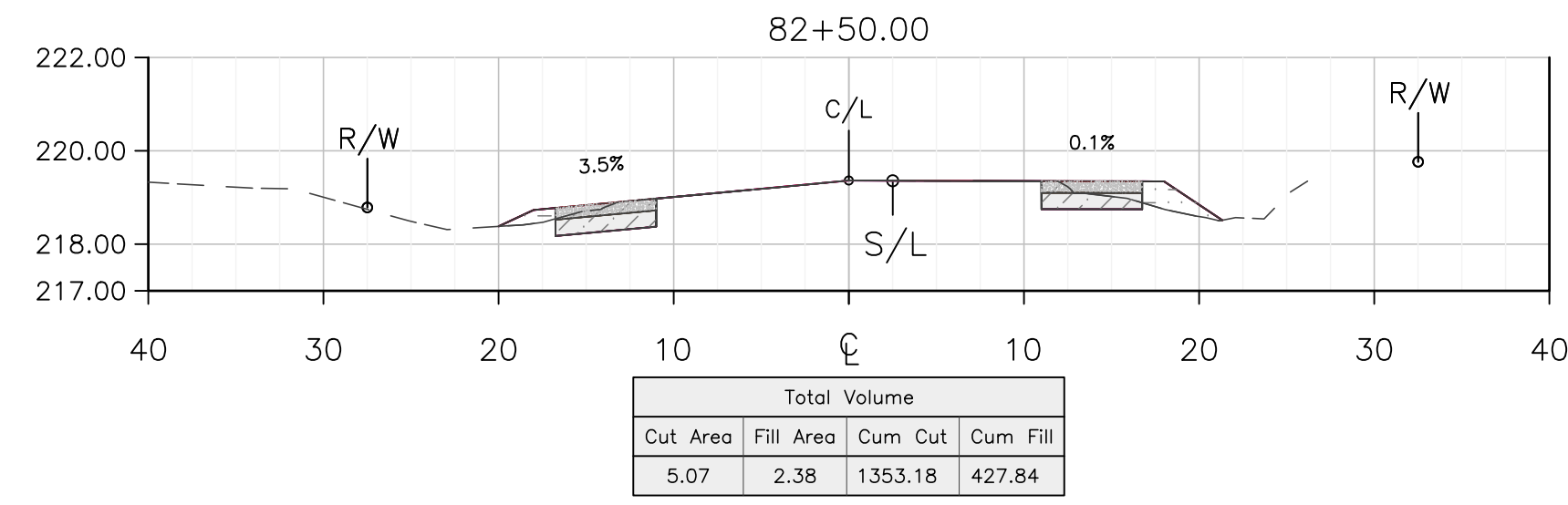
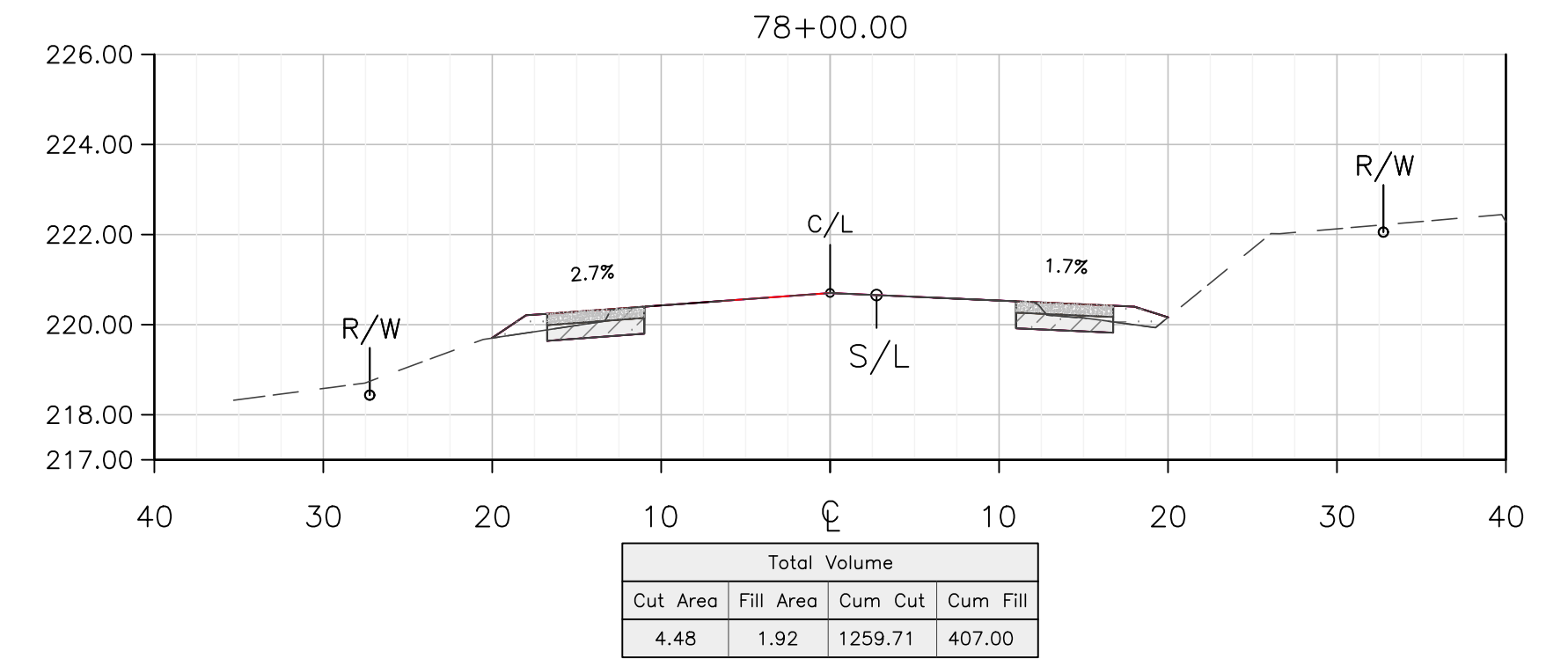
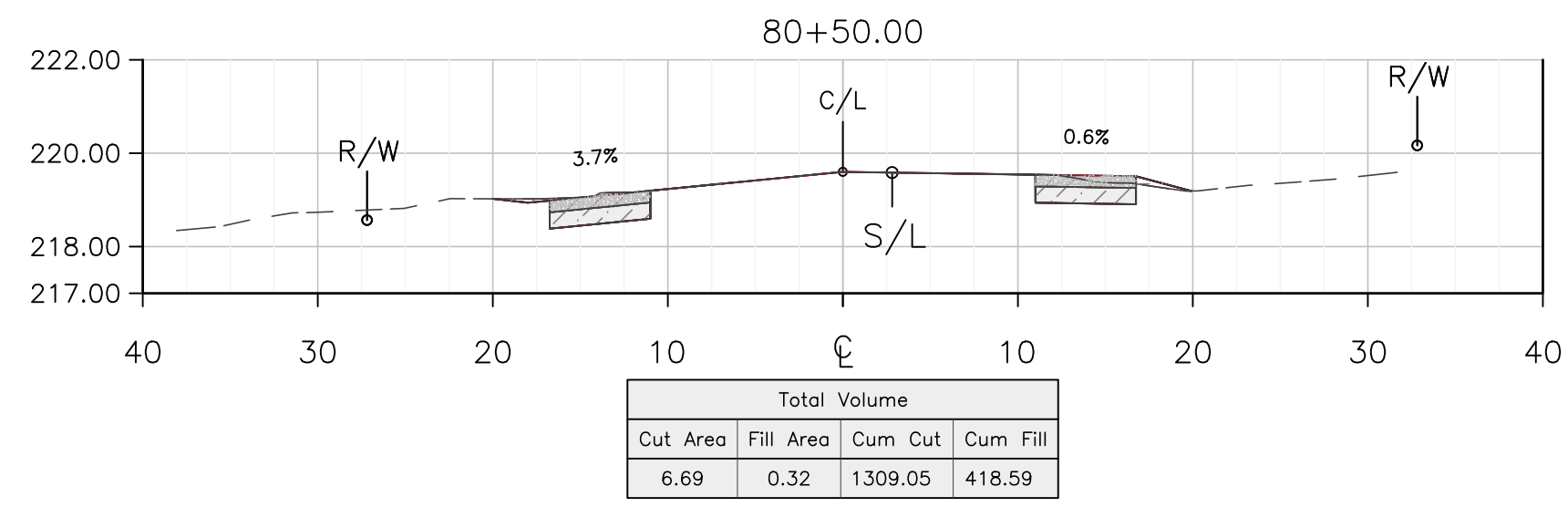
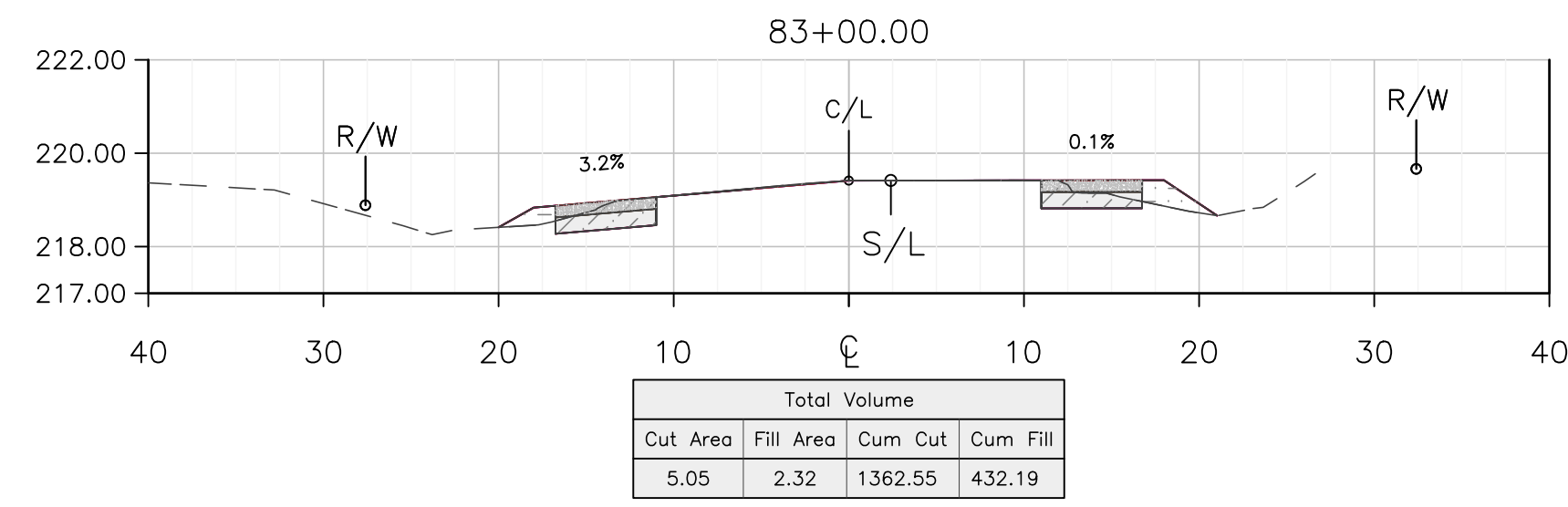
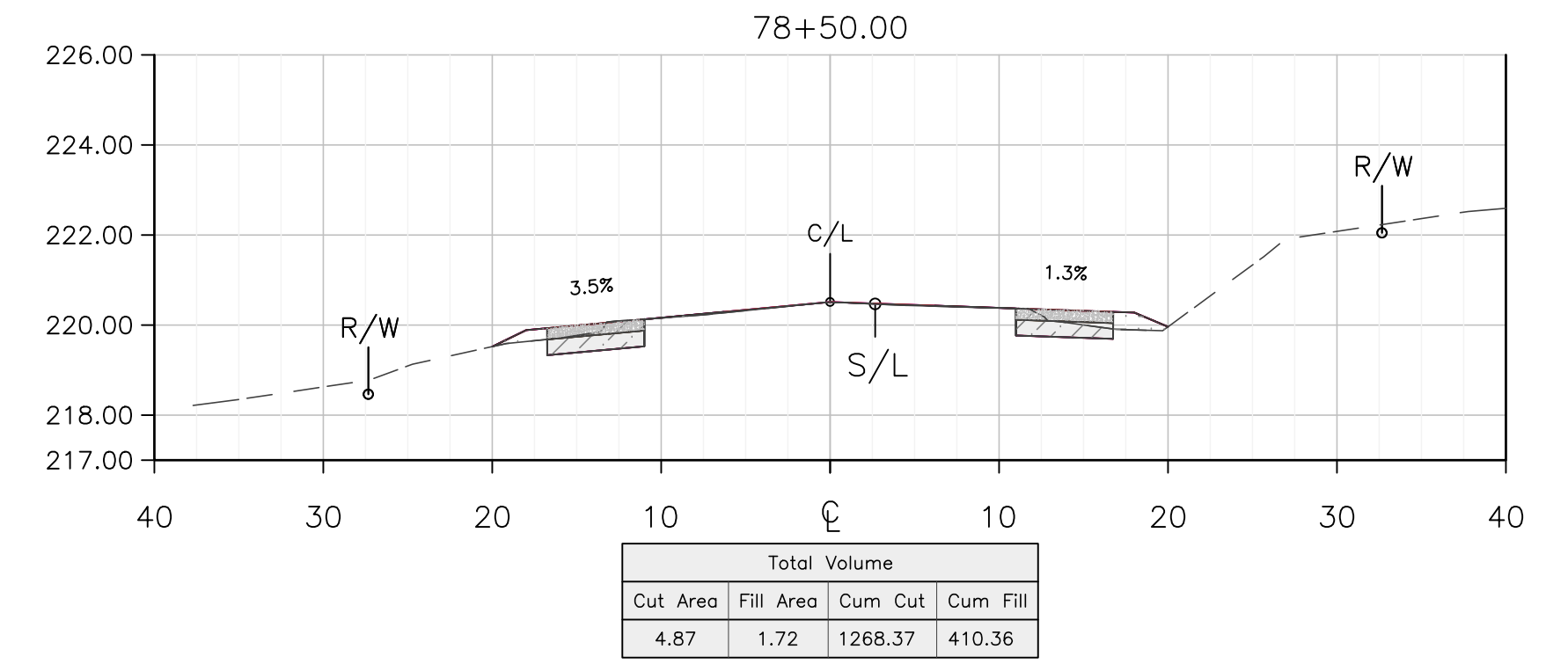
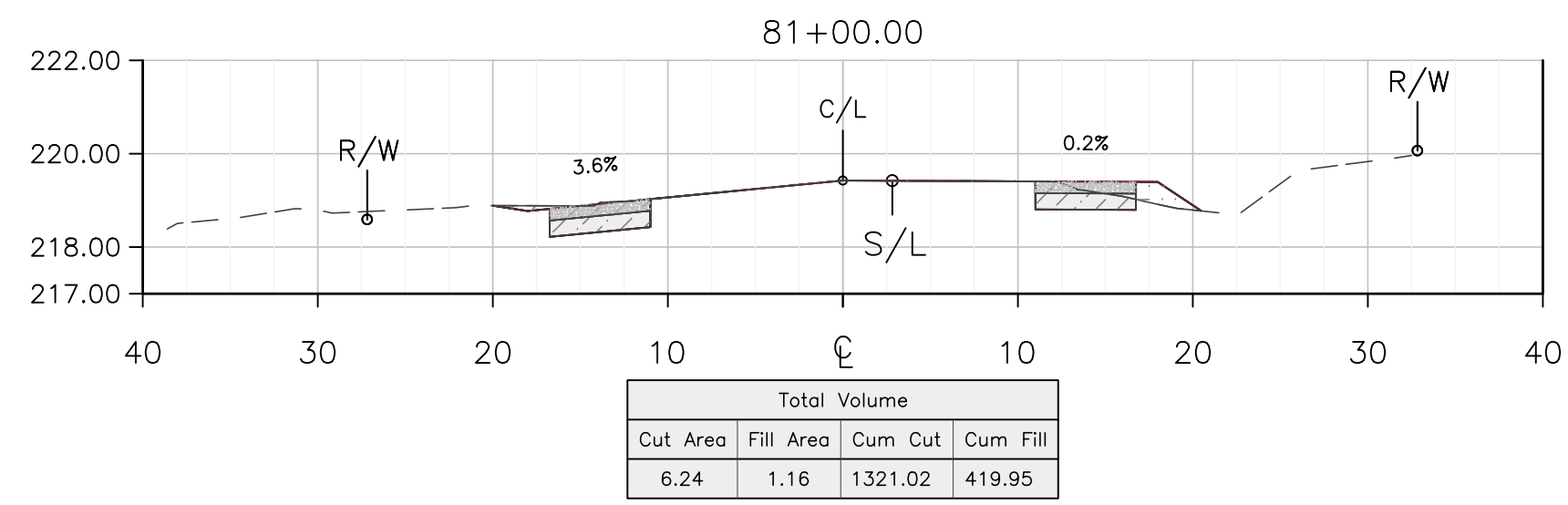
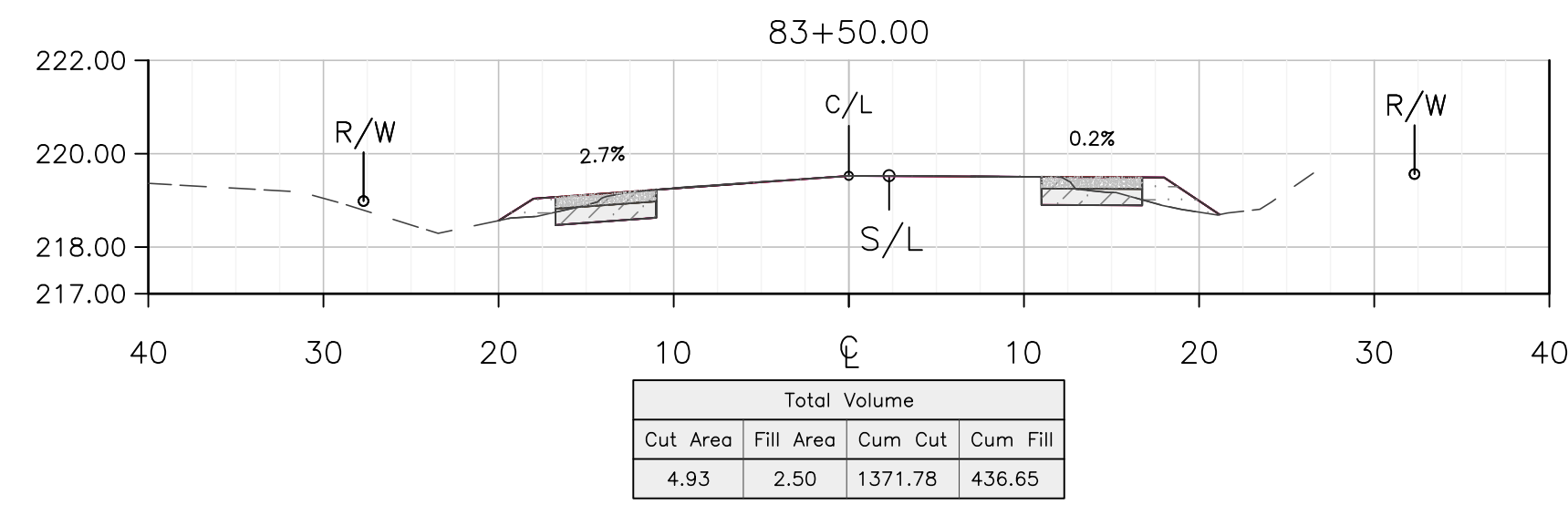
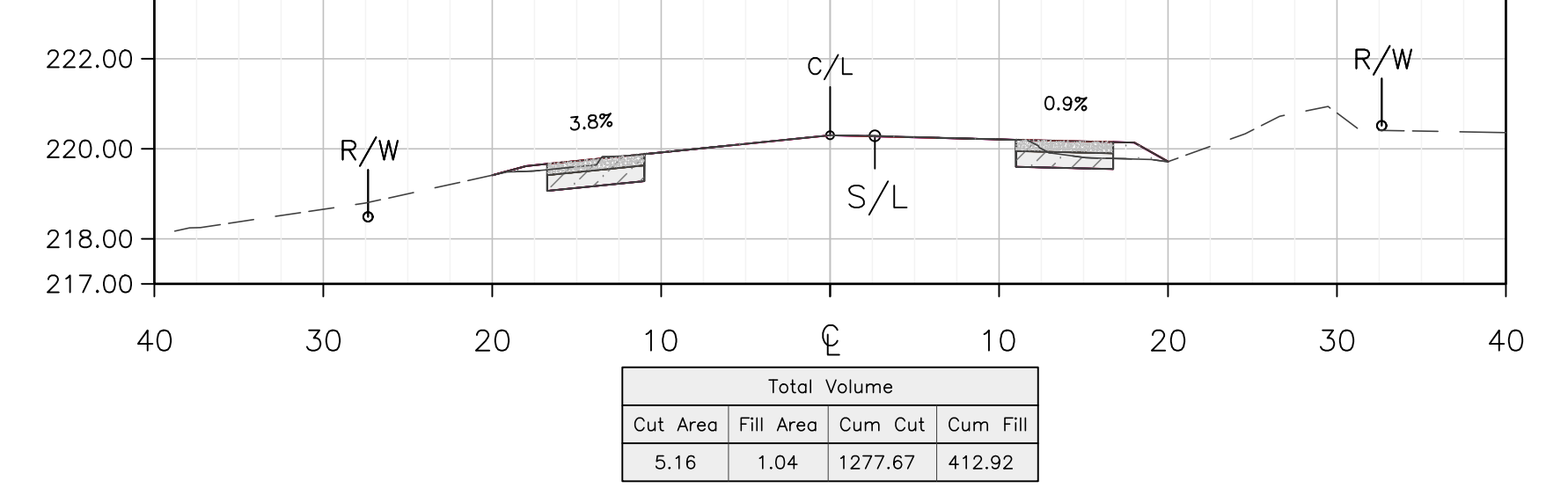
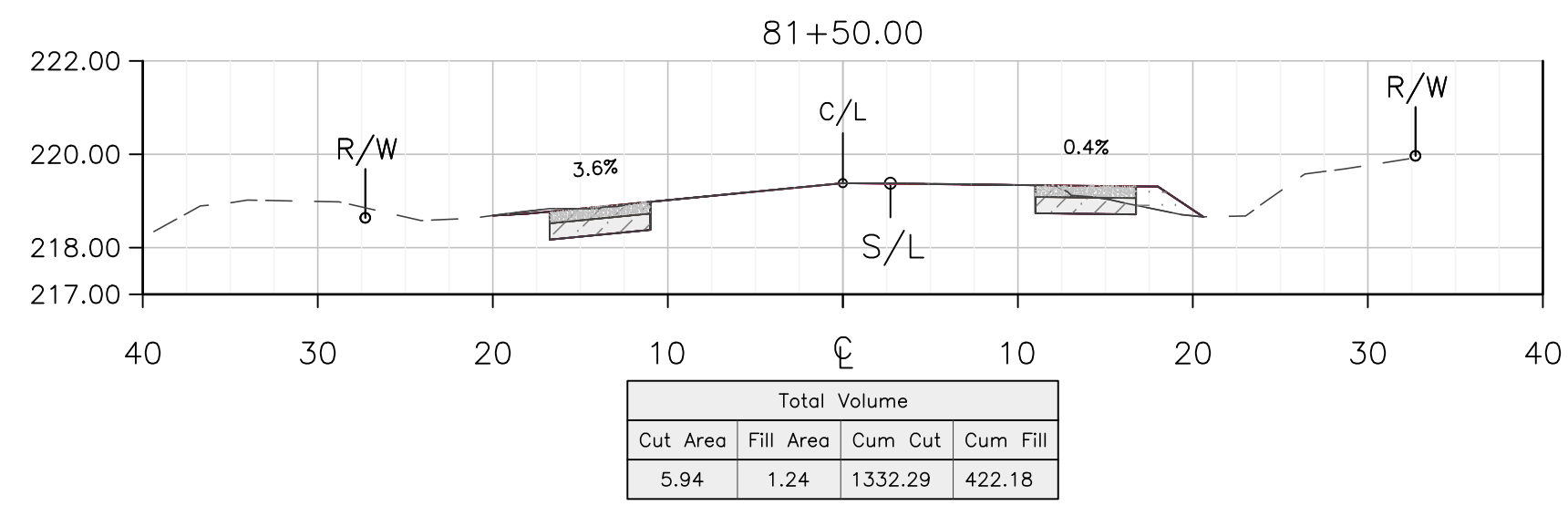
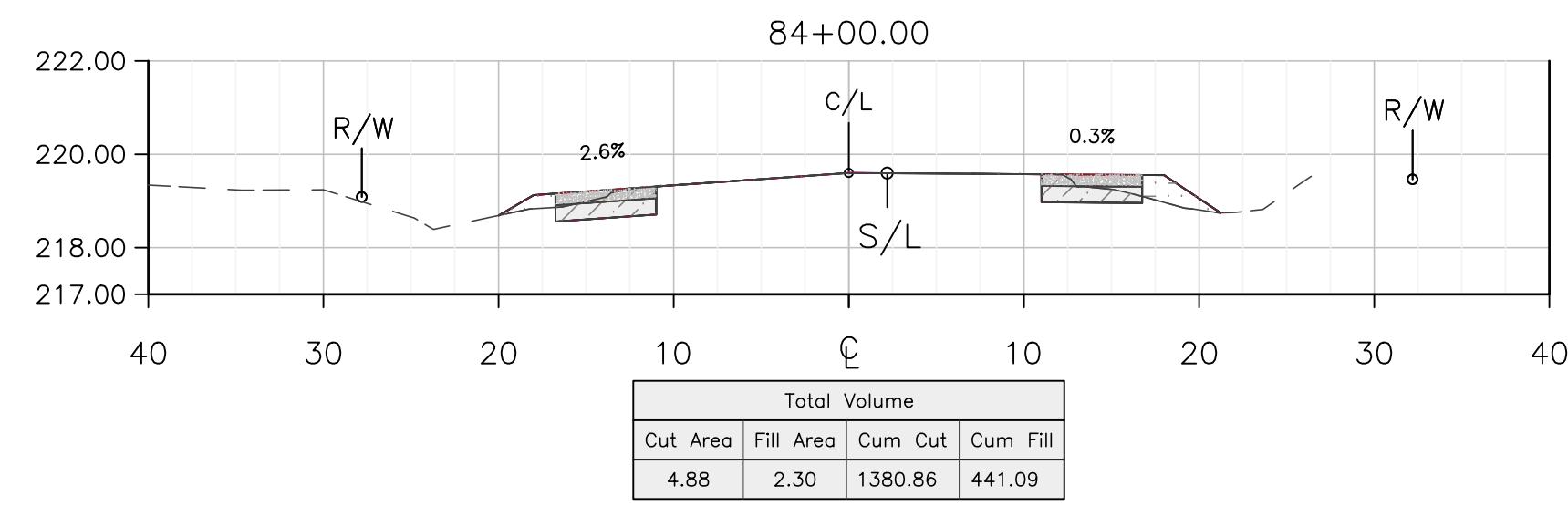

DEPARTMENT OF PUBLIC WORKS AND PLANNING
SHOULDER IMPROVEMENTS X-SECTIONS
DRAWING NO. ###
SHEET NO. C10
TOTAL ###

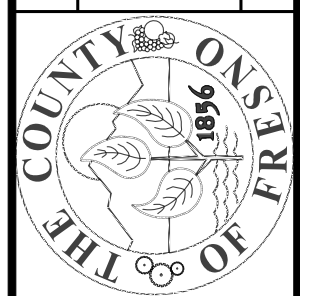

PROJECT
JENSEN AVENUE SHOULDER
IMPROVEMENTS & OVERLAY
MADERA AVE TO DICKENSON AVE
ROAD NO. ###
BRIDGE NO. ###

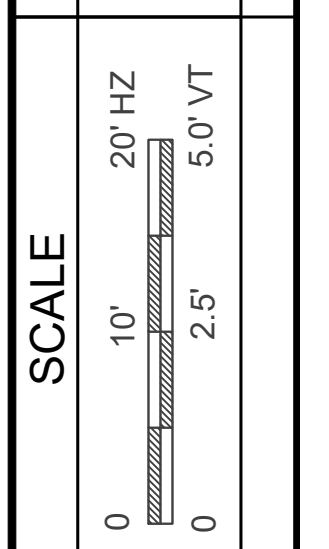

DATE
2/2020
2/2020
2/2020
DESIGNED: B.KHALIQ
DRAWN: B.KHALIQ
CHECKED: S.ARTAL

THESE CROSS SECTIONS ARE FOR THE CONTRACTOR'S INFORMATION ONLY. THEY ARE NOT TO BE CONSIDERED TO BE PART OF THE CONTRACT DOCUMENTS AND SHALL HAVE NO BEARING WHATSOEVER ON THE INTERPRETATION OF THE STANDARD SPECIFICATIONS, THE STANDARD PLANS, THE SPECIAL PROVISIONS, NOR SHALL THEY HAVE ANY BEARING WHATSOEVER ON THE INTERPRETATION OF THE OTHER PUBLICATIONS REFERENCED THEREIN.